



**General Catalogue
2024**



PEDROLLO S.p.A.

Via Enrico Fermi 7

37047 San Bonifacio (Verona) ITALY

Share capital € 100,000,000.00

Year of foundation 1974

tel. +39 045 6136311

fax +39 045 7612253

vendite@pedrollo.com

www.pedrollo.com

Pump Selector – The spring of data

The Pedrollo pump selector

<https://springofdata.pedrollo.com/selector>



Follow us also on:



www.pedrollo4people.com



Facebook
PedrolloCorporate
Pedrollo4People



Instagram



LinkedIn



YouTube



Vimeo

CONTENTS

PK		12
QP		18
PKS		22

Pump with peripheral impeller

CK		26
CKR		28

Liquid ring self-priming pumps

PQ-Bs		30
PQ81-PPS		34

Peripheral pumps for industrial use

PQA		36
------------	---	-----------

Peripheral pumps for industrial use

PV		38
-----------	---	-----------

Peripheral pumps for industrial use

PQ 3000		42
----------------	---	-----------

Peripheral pumps for industrial use

CP-ST4		44
CP-ST6		44

Stainless steel centrifugal pumps

CP		52
-----------	---	-----------

Centrifugal pumps

2CP		62
------------	---	-----------

Twin impeller centrifugal pumps

2-4CP - I		70
------------------	---	-----------

Multi-impeller centrifugal pumps

2-5CR		74
--------------	---	-----------

Multi-impeller centrifugal pumps

FCR		78
------------	---	-----------

Multi-impeller centrifugal pumps

MK		90
-----------	---	-----------

Multi-impeller centrifugal pumps

HT		94
HT-PRO		104

Multi-impeller centrifugal pumps

FUTURE JET		114
JSW		118

JET self-priming pumps

FUTURE JET-ST		126
JCR		130

JET self-priming pumps

MAGNIFICA		134
PRIMA		138
VILLABELLA		142
MAXIMA		146

Self-priming swimming pool pumps

SPRINKLER		150
------------------	---	------------

Self-priming centrifugal pumps

PLURIJET		154
-----------------	---	------------

Multi-impeller self-priming pumps

NGA		166
NGA-PRO		170

Centrifugal pumps with open impeller

HF Medium flow rates		174
HF High flow rates		178

Centrifugal pumps

WR		182
-----------	---	------------

Close-coupled centrifugal pumps

F		186
F-I		204
F4		206

Standardised centrifugal pumps EN733

FG		212
-----------	---	------------

Standardised centrifugal pumps EN733

FLUID SOLAR		216
--------------------	---	------------

4" Solar submersible pumps

4-BLOCK		220
----------------	---	------------

4" Close-coupled electric submersible pumps

DAVIS		226
--------------	---	------------

4" peripheral submersible pump

3SR		228
------------	---	------------

3" submersible pumps

4SR		234
6SR		244

4" and 6" submersible pumps

6ST		252
------------	--	------------

6" submersible pumps

4HR		256
6HR		260

4" and 6" submersible pumps

4PD		264
4PS		266
6PD		268
6PSR		270

4" and 6" submersible motors

TOP MULTI		272
------------------	---	------------

Multi-impeller submersible pumps

UP		288
NK		292

Multi-impeller submersible pumps

TOP		296
------------	---	------------

Submersible drainage pumps

TEX  **308**

VORTEX submersible pumps

TOP MULTI-AD  **312**

Submersible pump for AdBlue®

PLUG & DRAIN  **314**

Anti-flooding kit

RX  **316**

Submersible drainage pumps

VX-ST **328**

BC-ST **332**

Stainless steel submersible pumps

VX-MF **338**

BC-MF **342**

Micro-cast stainless steel submersible pumps

D  **348**

Submersible pumps for drainage

ZXm2  **352**

Submersible pump

FAMILY  **356**

Submersible pump

ZXm1  **358**

Submersible pumps

VX **360**

BC **364**

Submersible pumps

VXC **368**

MC **372**

Submersible pumps

DC  **374**

Submersible pumps

TRITUS-TX  **378**

Submersible pumps with grinder

TRITUS-INOX  **380**

Submersible pumps with grinder

TRITUS  **384**

Submersible pumps with grinder

VXC **396**

MC **400**

Submersible pumps

VXC-F **404**

MC-F **408**

Flanged submersible pumps

VX40-50-65 **414**

BC35 **418**

Submersible pumps

VX4 **424**

BC4 **428**

Submersible pumps - 4 POLES

VXC4 Medium flow rates **434**

MC4 Medium capacities **438**

VXC4 High flow rates **444**

MC4 High flow rates **448**

Submersible pumps - 4 POLES

SAR  **454**

Accumulation and lifting stations

EASYPUMP  **462**

Pumps with pressure regulator

HYDROFRESH  **463**

Automatic pressure units

DG-BLU  **464**

Pressurisation system with inverter

EASYSMALL  **468**

Automatic control devices

PRESFLO VARIO **470**

PRESFLO MULTI **471**

PRESET  **472**

Automatic control devices

EP  **473**

Electronic protection device

STEADYPRES  **474**

476

Inverter with water passage

DG-FIT **478**

PRO-DG  **480**

Wall-mounted inverter

CB2  **482**

Fixed speed pressure units

TISSSEL-100  **502**

Pumps with inverters

VSP  **506**

Pumps with inverters

VSP2 **522**

GPW  **538**

Variable speed pumping units

DHL  **550**

Circulators for heating systems

E1 - E2  **552**

Multifunctional electronic boards

SWITCHBOARDS  **554**

ACCESSORIES **557**

BEARINGS **568**

CAPACITORS **571**

OUR GROUP

The Pedrollo Group brings together a range of companies specialising in water, energy, and technology. We are committed to meeting the varied needs of our diverse client base, providing tailored solutions across these essential sectors.

 <p>PEDROLLO the spring of life</p> <p>Pumps for domestic, agricultural and industrial use</p>	 <p>saci pumps</p> <p>Swimming pool pumps</p>	 <p>City pumps</p> <p>Pumps in stainless steel for special purposes</p>	 <p>LINZ ELECTRIC</p> <p>Alternators and rotating machines</p>
 <p>PEDROLLO GROUP</p> <p>BRANCHES France, Hungary, Romania, United Arab Emirates, Mexico, Colombia, Guatemala, USA, Thailand, Germany, Poland, Linz Electric Inc.</p>	 <p>PANELLI</p> <p>Pumps and submersible motors</p>	 <p>SUPERIOR PUMP DON'T YOU LIST</p> <p>Residential and commercial pumps</p>	 <p>gread elettronica</p> <p>Software and electronic equipment</p>

WATER **ENERGY** **TECNOLOGY**

WHERE WE ARE | **Italy:** Pedrollo - Linz Electric - Panelli - City Pumps - Gread Elettronica
Spain: Saci Pumps
USA: Superior Pump

WHAT WE DO

Water, energy, technology

The **Pedrollo Group** is a leader in water management, energy, and technology solutions. We are committed to tackling the world's most pressing daily challenges. We focus on driving economic growth, enhancing human well-being, and safeguarding our environment. Given the urgency of these critical missions, our dedication is more crucial than ever.





OUR NUMBERS

3 million pumps sold annually in

160 Countries around the world

12 Branches

5 Continents

The Pedrollo Industrial District

240,000 m² of industrial space in San Bonifacio

130,000 m² houses all Pedrollo departments, divisions, and offices

DESIGN, CREATIVITY AND QUALITY

INNOVATION MADE IN ITALY





CIRCULAR ECONOMY

Annually, our commitment to sustainability enables us to reclaim and recycle significant materials from our production processes, including over:

- 15** tonnes of plastic
- 485** tonnes of steel
- 58** tonnes of aluminium



PHOTOVOLTAIC SYSTEM

- Installed power:** over **3.5 MW**
- Energy output:** over **3,000,000 kWh/year**
- CO₂ saved:** over **1,200 tonnes/year**



CORPORATE GREEN AREAS

Our commitment to green spaces at our headquarters is vital for optimising the microclimate in our offices and operational zones.

So far, we have:

- Planted **556** trees from **36** species.
- Incorporated **25,000** bushes and shrubs.
- Developed **40,000 m²** of beautifully landscaped space

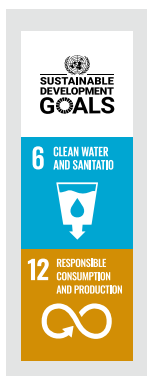

RAINWATER SYSTEMS

By the first half of 2023, we had saved over **2.5 million litres of rainwater**, re-purposing it for industrial and agricultural needs.

WATER MANAGEMENT

We reclaim **90%** of the water used in our production processes through vacuum evaporation, totalling more than **1 million litres annually**.

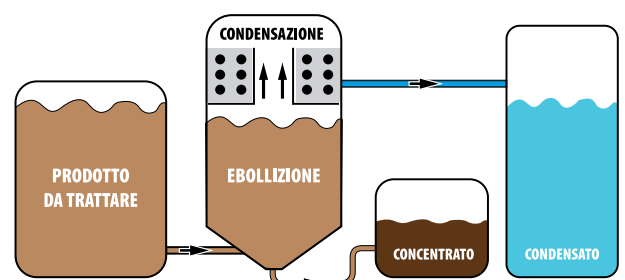

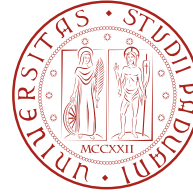

UNIVERSITY OF PADUA



POSITIVE IMPACT

The **ETIFOR Report** carried out by the **University of Padua** measured the positive impact of our green areas on the environment and the business ecosystem.

CO₂ consumption:
22 TONNES/YEAR

Oxygen produced:
16 TONNES/YEAR

Reduction of water dispersion:
48,000 LITRES/YEAR

Removal of various pollutants:
CO - NO₂ - O₃ - PM10 - PM2.5 - SO₂



PEDROLLO FOR CULTURE

Pedrollo has established close partnerships with several universities and training institutions to foster cultural and talent development. Among these partnerships, the "**Arrigo Pedrollo**" Conservatory in **Vicenza** holds a special place. Named after the Pedrollo family and maintaining a close connection to their cultural origins, it collaborates with over 100 dedicated teachers and annually educates over 700 young musicians worldwide. This partnership exemplifies Pedrollo's unwavering commitment to preserving and nurturing their community's cultural and artistic heritage.



LOOKING FORWARD TO THE FUTURE

A unique corporate environment,
fully sustainable and
technologically advanced



EXCELLENCE IN CREATIVITY AND INNOVATION

- **Leonardo da Vinci Award 2022**
Paris
- **Italian Quality Award 2015**
Quirinale Palace, Rome



WATER, HEALTH, CULTURE, COMMUNITY



Our dedication to global solidarity and sustainable development has empowered us to construct over 1,300 wells, ensuring clean water for more than 2 million people. This initiative facilitates the availability of fresh drinking water and promotes more hygienic and sanitary living conditions. By improving hygiene and health, we contribute to creating better environments for families to nurture their children, reinforcing our commitment to enhancing the quality of life and fostering thriving communities worldwide.

STANDARD VERSIONS

VOLTAGES

- Single-phase: **230 V - 50 Hz** with built-in circuit breaker (motor protection).
- Three-phase up to 4 kW and three-phase 4-pole: **230/400 V - 50 Hz.**
- Three-phase 5.5 kW: **400/690 V - 50 Hz.**

CAPACITORS

- Capacitors in accordance with EN 60252-1/A1  

YIELDS AND ENERGY EFFICIENCY

- **The single-phase surface pumps are equipped with high-efficiency motors of class IE2 (IEC 60034-30-1)**
- **Three-phase surface pumps are equipped with high-efficiency motors in class IE3 (IEC 60034-30-1)**
- **Pumps that fall within the scope of the EU Regulation No. 547/2012 must have a minimum efficiency index $MEI \geq 0.40$**

REGULATION (EU) NO 547/2012

- Pumps with a Minimum Efficiency Index (MEI) ≥ 0.40 comply with EU Regulation 547/2012, effective January 1st, 2015.
- The benchmark for the most efficient water pumps is $MEI \geq 0.70$.
- The efficiency of a pump with a trimmed impeller is usually lower than that of a pump with a full impeller diameter. The trimming of the impeller will adapt the pump to a fixed-duty point, leading to reduced energy consumption. The minimum efficiency index (MEI) is based on the full impeller diameter.
- The operation of this water pump with variable duty points may be more efficient and economical when controlled, for example, by using a variable speed drive that matches the pump duty to the system.
- Information on benchmark efficiency is available at: www.europump.org/efficiencycharts

USES

- Install in enclosed and well-ventilated areas or locations that offer adequate protection from adverse weather conditions
- The 10 m power cable is mandatory for outdoor use according to EN 60335-2-41

EXECUTION AND SAFETY STANDARDS

- EN 60335-1
- IEC 60335-1
- CEI 61-150
- EN 60034-1
- IEC 60034-1
- CEI 2-3

SPECIAL DESIGN

- Pumps with special voltages or 60 Hz frequency.
- Pumps with special mechanical seals, suitable for the different liquids to be conveyed.
- Surface pumps with IP X5 protection.
- Submersible pumps without float.

SPECIAL WINDINGS ON REQUEST

- 110 V - 50 Hz (Single-phase)
- 240 V - 50 Hz (Single-phase)
- 110 V - 60 Hz (Single-phase)
- 220 V - 60 Hz (Single-phase)
- 240/415 V - 50 Hz (Three-phase)
- 220/380 V - 60 Hz (Three-phase)

CERTIFICATIONS AND MARKS



WARRANTY

- Our products have a comprehensive 2-year warranty, subject to the terms and conditions outlined in our general agreement

※ **The PKm 60® a cornerstone since 1974, an integral part of our future.**



- ※ **50 years of success since 1974**
- ※ **Produced over 23 million units**
- ※ **Made from premium materials and components**
- ※ **Our most economical and versatile product**
- ※ **Noise level reduced by 20 %**
- ※ **Exclusively produced with renewable energy sources**

PERFORMANCE RANGE

- Flow rate up to **40 l/min** (2.4 m³/h)
- Head up to **40 m**

INSTALLATION AND USE

Designed to transfer clean water free from abrasive particles and liquids that will not damage the pump's components.

Reliable, easy to operate, and cost-effective. It is ideal for domestic applications, specifically for gardens and orchards, in combination with small autoclave tanks.

ELECTRIC MOTOR

Three-phase pumps feature **IE3**-class electric motors, while single-phase models use **IE2** motors. All are designed with class F insulation and IPX4 protection.

APPLICATION LIMITS

- Manometric suction head up to **8 m**
- Liquid temperature between **-10 °C** and **+60 °C**
- Ambient temperature up to **+50 °C**
- Maximum working pressure **6 bar**

PATENTS - TRADE MARKS - MODELS

- Motor bracket: Patent No. IT1243605
- Pump body: Patent No. 0000275946
- Registered community model No. 018625876
- International registered model No. DM/220613
- PKm 60® Registered Trade mark No. 009875394

AVAILABLE UPON REQUEST

- ※ Different voltage requirements 60 Hz frequency

CURVES AND PERFORMANCE DATA – HS=0 m

50 Hz

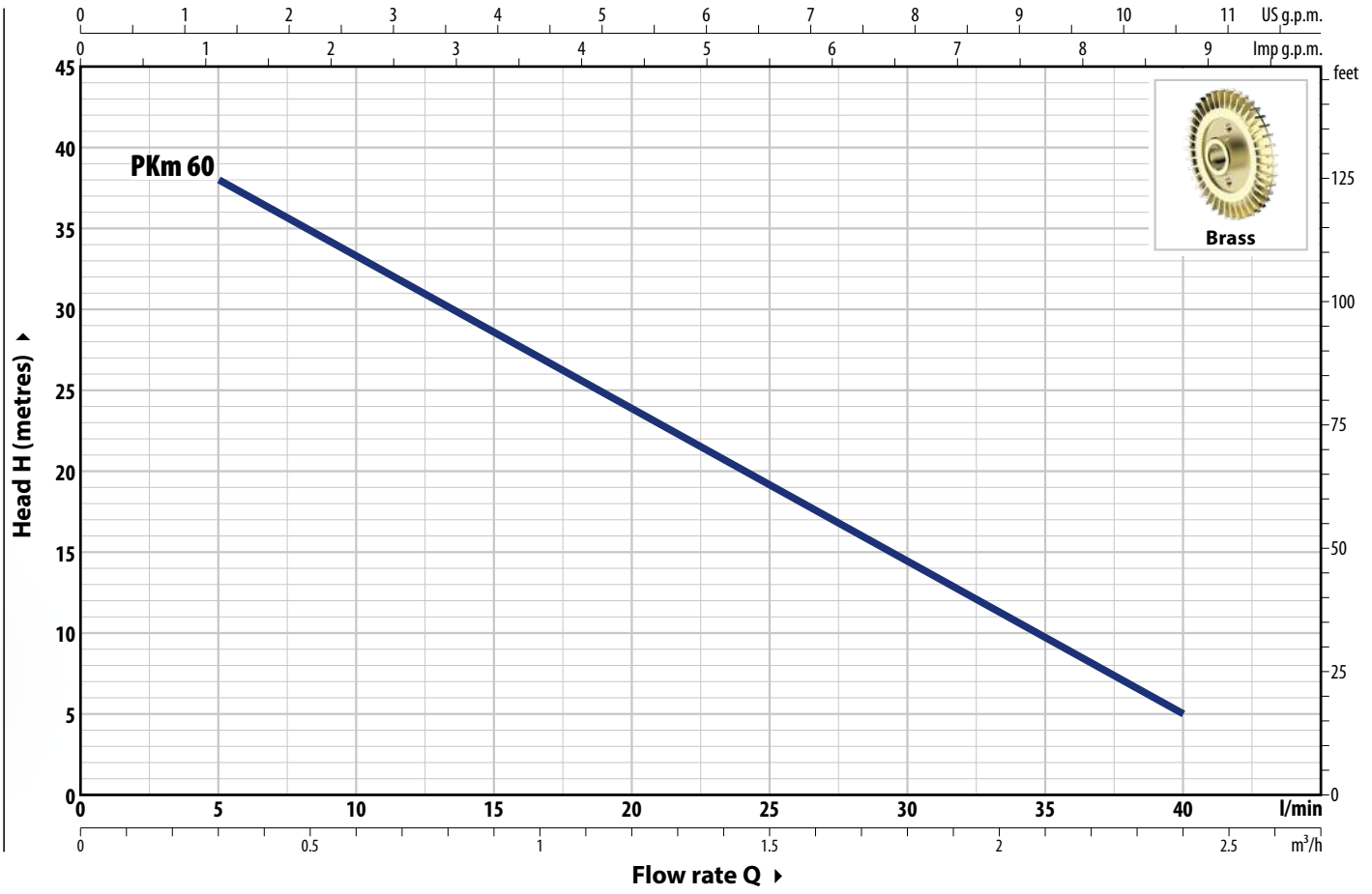

TYPE		POWER (P ₂)		Q	Flow rate													
Single-ph.	Three-ph.	kW	HP		1~	3~	m ³ /h	0	0.3	0.6	0.9	1.2	1.5	1.8	2.1	2.4		
PKm 60	PK 60	0.30	0.40	IE2	IE3	H metres	40	38	33.5	29	24	19.5	15	10	5			

Q = Flow rate H = Total manometric head HS = Suction height

Performance curves comply with EN ISO 9906 Grade 3B tolerance limits.

ABSORPTION

TYPE	VOLTAGE
Single-phase	230 V
PKm 60°	2.3 A

TYPE	VOLTAGE	
Three-phase	230 V - Δ	400 V - 人
PK 60°	2.0 A	1.15 A

DIMENSIONS AND WEIGHT

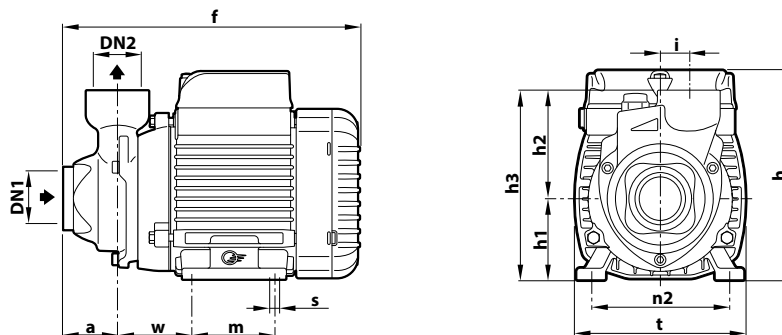

TYPE		PORTS		DIMENSIONS mm												kg		PALLET CAPACITY
Single-ph.	Three-ph.	DN1	DN2	a	f	h	h1	h2	h3	i	m	t	n2	w	s	1~	3~	
PKm 60°	PK 60°	1"	1"	38	208	145	56	75	131	20	55	118	94-100	53	7	5.0	5.0	240

※ New version featuring a 20% reduction in noise levels.



PERFORMANCE RANGE

- Flow rate up to **90 l/min** (5.4 m³/h)
- Head up to **100 m**

INSTALLATION AND USE

Designed to transfer clean water free from abrasive particles and liquids that will not damage the pump's components.

Reliable, easy to operate, and cost-effective. They are ideal for domestic applications, specifically for gardens and orchards, in combination with small autoclave tanks.

APPLICATION LIMITS

- Manometric suction head up to **8 m**
- Liquid temperature between **-10 °C** and **+60 °C**
- Ambient temperature up to **+40 °C**
- Maximum working pressure:
 - **6 bar** for PK 65
 - **7 bar** for PK 80
 - **10 bar** for PK 90, PK 100, PK 200, PK 300

AVAILABLE UPON REQUEST

- ※ Mechanical seal options available
- ※ Protection rating IP X5 for PK 80-90-100-200-300
- ※ Different voltage requirements 60 Hz frequency

PATENTS - TRADE MARKS - MODELS

- Motor bracket: Patent No. IT1243605
- Pump body: Patent No. 0000275946 (PK65)

CURVES AND PERFORMANCE DATA - HS=0 m

50 Hz

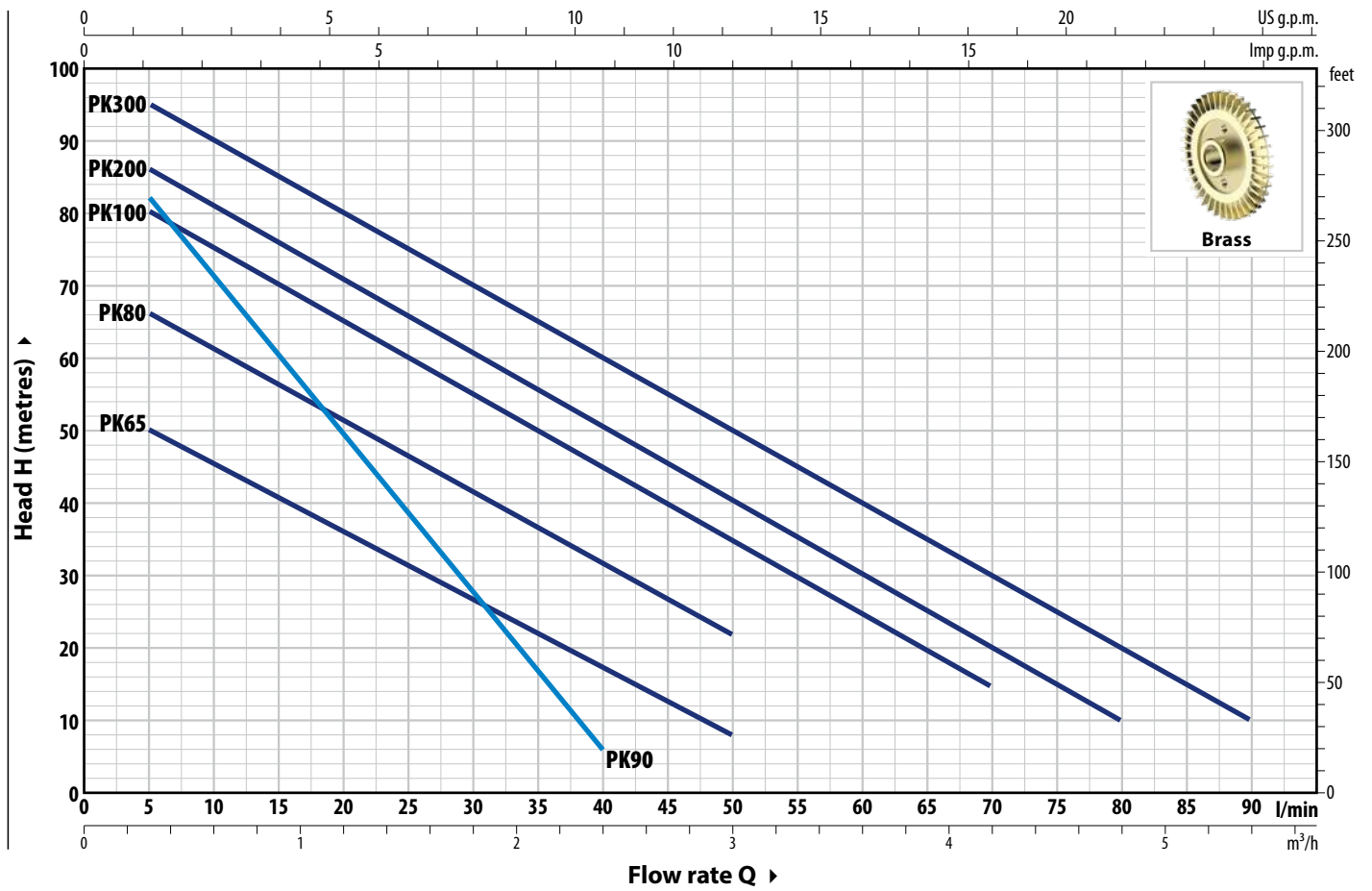

TYPE		POWER (P ₂)		1~3~	Q	H metres																		
Single-ph.	Three-ph.	kW	HP			0	0.3	0.6	0.9	1.2	1.5	1.8	2.1	2.4	3.0	3.6	4.2	4.8	5.4					
				IE2	IE3	0	5	10	15	20	25	30	35	40	50	60	70	80	90					
PKm 65	PK 65	0.55	0.75	IE2	IE3	55	50	45.5	40.5	36	31	27	22	17	8									
PKm 80	PK 80	0.75	1			70	66	61	56	51	46	41	36.5	31	22									
PKm 90	PK 90	0.75	1			90	82	71	60	49	38	27	17	5										
PKm 100	PK 100	1.1	1.5			85	80	75	70	65	60	55	50	45	35	24.5	15							
PKm 200	PK 200	1.5	2			90	86	81	76	71	65.5	60	55	50	40	30	20	10						
PKm 300	PK 300	2.2	3			100	95	90	85	80	75	70	65	60	50	40	30	20	10					

Q = Flow rate H = Total manometric head HS = Suction height

Performance curves comply with EN ISO 9906 Grade 3B tolerance limits.

ABSORPTION

TYPE	VOLTAGE
Single-phase	230 V
PKm 65	3.7 A
PKm 80	5.2 A
PKm 90	5.6 A
PKm 100	9.0 A
PKm 200	11.5 A
PKm 300	12.0 A

TYPE	VOLTAGE	
Three-phase	230 V - Δ	400 V - 人
PK 65	2.9 A	1.7 A
PK 80	3.8 A	2.2 A
PK 90	4.0 A	2.3 A
PK 100	6.2 A	3.6 A
PK 200	8.3 A	4.8 A
PK 300	9.0 A	5.2 A

DIMENSIONS AND WEIGHT

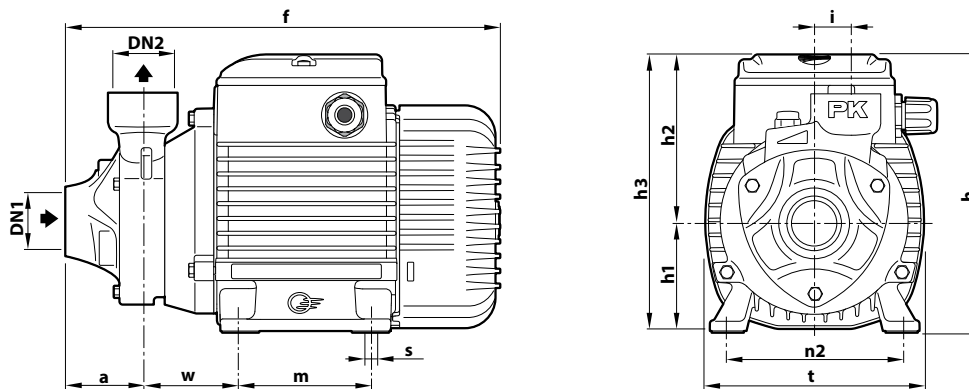

TYPE		PORTS		DIMENSIONS mm											kg		
Single-ph.	Three-ph.	DN1	DN2	a	f	h	h1	h2	h3	i	m	t	n2	w	s	1~	3~
PKm 65	PK 65	1"	1"	38	237	153	63	75	138	20	80	120	100	53	7	6.9	6.3
PKm 80	PK 80			55	285	179 *	71	85	156		90	140	112	62		10.3	10.3
PKm 90	PK 90	3/4"	3/4"	46	278			84	155	19						10.3	10.3
PKm 100	PK 100	1"	1"		356											15.1	15.1
PKm 200	PK 200			62	212	80	88	168	19	100	152	125	95	9	16.3	16.3	
PKm 300	PK 300				376											18.9	18.8

(*) h=199 mm for single-phase 110 V versions

PALLET CAPACITY

TYPE		NO. OF PUMPS
Single-ph.	Three-ph.	
PKm 65	PK 65	189
PKm 80	PK 80	119
PKm 90	PK 90	102
PKm 100	PK 100	72
PKm 200	PK 200	72
PKm 300	PK 300	72

CONSTRUCTION FEATURES

1 Pump body Cast iron with ISO 228/1 threaded ports

2 Motor bracket Aluminum with brass cover and front scraping anti-locking function (patented)

3 Impeller Brass, radial peripheral vane type

4 Mechanical seal	Pump	Seal	Shaft	Materials
	PK 60-65-80	AR-12	Ø 12 mm	Ceramic / Graphite / NBR
	PK 90	ST1-12	Ø 12 mm	Silicon carbide / Graphite / NBR
	PK 100-200-300	FN-14	Ø 14 mm	Graphite / Ceramic / NBR

5 Motor shaft Stainless steel **AISI 431**
(EN 10088-3 - 1.4104 for PK 60, PK 65)

6 Electric motor **PKm**: single-phase 230 V - 50 Hz with winding integrated thermal motor protection.
PK: three-phase 230/400 V - 50 Hz
 ※ Pumps are equipped with high-efficiency motors (IEC 60034-30-1)
 class **IE2** for single-phase models
 class **IE3** for three-phase models
 – Continuous running duty **S1**
 – Insulation: class F
 – Protection rating: IP X4

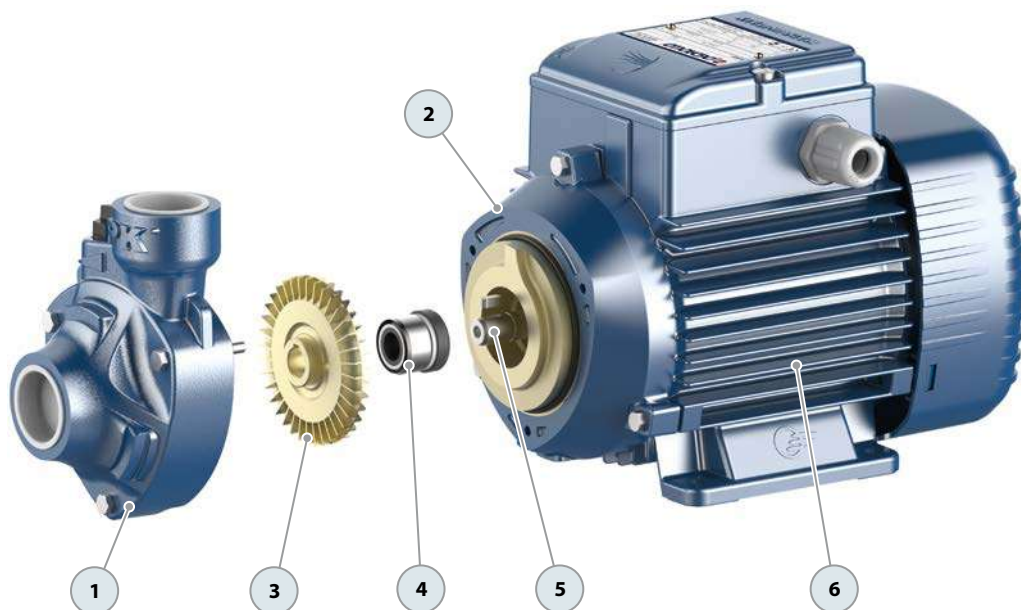

※ **New version featuring a 20% reduction in noise levels.**



PERFORMANCE RANGE

- Flow rate up to **90 l/min** (5.4 m³/h)
- Head up to **100 m**

INSTALLATION AND USE

Peripheral pump with radial suction.

Designed to transfer clean water free from abrasive particles and liquids that will not damage the pump's components.

Its compact design and efficient hydraulic performance make it ideal for **domestic applications**.

APPLICATION LIMITS

- Manometric suction head up to **8 m**
- Liquid temperature between **-10 °C** and **+60 °C**
- Ambient temperature up to **+40 °C** (**+50 °C** for PQ 60 and PQ61)
- Maximum working pressure:
 - **6 bar** for PQ 60, PQ 61, PQ 65
 - **7 bar** for PQ 80
 - **10 bar** for PQ 90, PQ 100, PQ 200, PQ 300

AVAILABLE UPON REQUEST

- ※ Pumps for industrial use
- ※ Mechanical seal options available
- ※ Protection rating IP X5 for PQ 80-90-100-200-300
- ※ Different voltage requirements 60 Hz frequency

PATENTS - TRADE MARKS - MODELS

- Motor bracket: Patent No. IT1243605
- Registered community model No. 002146548
- PQm 60® Registered trademark No. 0001520591

CURVES AND PERFORMANCE DATA – HS=0 m

50 Hz

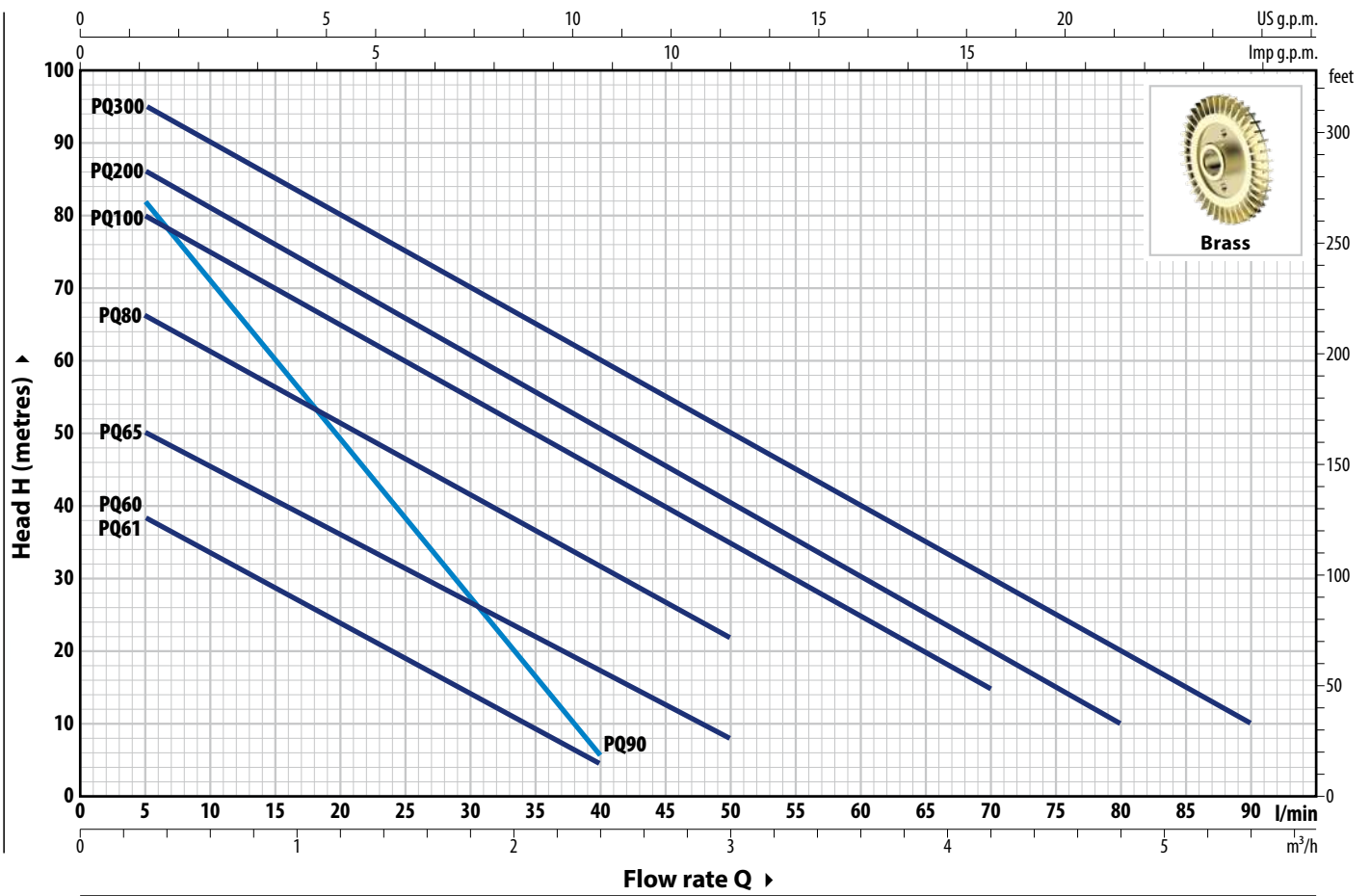

TYPE		POWER (P ₂)		1~	3~	Q	H metres																
Single-ph.	Three-ph.	kW	HP				0	0.3	0.6	0.9	1.2	1.5	1.8	2.1	2.4	3.0	3.6	4.2	4.8	5.4			
						l/min	0	5	10	15	20	25	30	35	40	50	60	70	80	90			
PQm 60	PQ 60	0.30	0.40	IE2	IE3	H metres	40	38	33.5	29	24	19.5	15	10	5								
PQm 61	PQ 61	0.30	0.40				40	38	33.5	29	24	19.5	15	10	5								
PQm 65	PQ 65	0.55	0.75				55	50	45.5	40.5	36	31	27	22	17	8							
PQm 80	PQ 80	0.75	1				70	66	61	56	51	46	41	36.5	31	22							
PQm 90	PQ 90	0.75	1				90	82	71	60	49	38	27	17	5								
PQm 100	PQ 100	1.1	1.5				85	80	75	70	65	60	55	50	45	35	25	15					
PQm 200	PQ 200	1.5	2				90	86	81	76	71	65.5	60	55	50	40	30	20	10				
PQm 300	PQ 300	2.2	3				100	95	90	85	80	75	70	65	60	50	40	30	20	10			

Q = Flow rate H = Total manometric head HS = Suction height

Performance curves comply with EN ISO 9906 Grade 3B tolerance limits.

ABSORPTION

TYPE	VOLTAGE
Single-phase	230 V
PQm 60	2.3 A
PQm 61	2.3 A
PQm 65	3.7 A
PQm 80	5.2 A
PQm 90	5.6 A
PQm 100	9.0 A
PQm 200	12.0 A
PQm 300	13.0 A

TYPE	VOLTAGE	
Three-phase	230 V - Δ	400 V - 人
PQ 60	2.0 A	1.15 A
PQ 61	2.0 A	1.15 A
PQ 65	2.9 A	1.7 A
PQ 80	3.8 A	2.2 A
PQ 90	4.2 A	2.4 A
PQ 100	6.2 A	3.6 A
PQ 200	8.3 A	4.8 A
PQ 300	9.0 A	5.2 A

DIMENSIONS AND WEIGHT

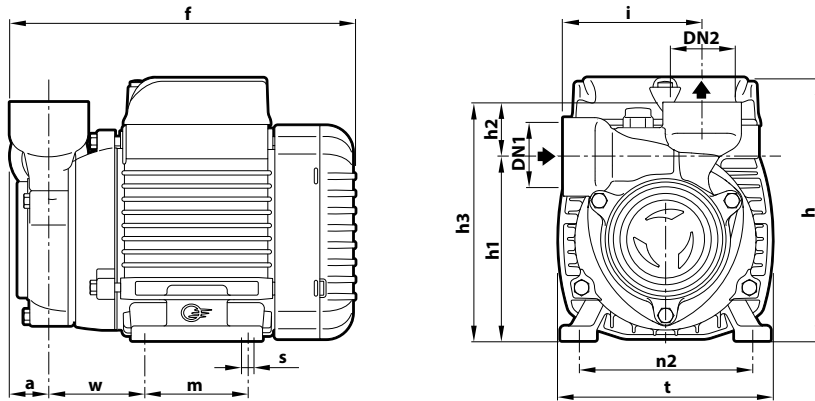

TYPE		PORTS		DIMENSIONS mm												kg	
Single-ph.	Three-ph.	DN1	DN2	a	f	h	h1	h2	h3	i	m	t	n2	w	s	1~	3~
PQm 60	PQ 60	1"	1"	22	192	145	101	30	131	76	55	118	94-100	53	7	4.9	4.9
PQm 61	PQ 61	1/2"	1/2"					32.5	133.5							4.9	4.9
PQm 65	PQ 65	1"	1"	22	220	152	113	30	143	78	80	120	100	62.5	7	6.8	6.2
PQm 80	PQ 80							151	83							9.9	9.9
PQm 90	PQ 90	3/4"	3/4"	22	256	152(*)	126	27	153	84	90	142	112	62.5	7	10.1	10.1
PQm 100	PQ 100	140	168					88	100							164	125
PQm 200	PQ 200	1"	1"	29	322.5	211	140	28	168	88	100	164	125	95	9	15.4	15.4
PQm 300	PQ 300															342.5	18.2

(*) h=199 mm for single-phase 110 V versions

PALLET CAPACITY

TYPE		NO. OF PUMPS
Single-ph.	Three-ph.	
PQm 60	PQ 60	256
PQm 61	PQ 61	256
PQm 65	PQ 65	210
PQm 80	PQ 80	102
PQm 90	PQ 90	102
PQm 100	PQ 100	72
PQm 200	PQ 200	72
PQm 300	PQ 300	72

CONSTRUCTION FEATURES

1 Pump body Cast iron with ISO 228/1 threaded ports
For PQ 61: cast iron with anti-locking treatment with ISO 228/1 threaded ports

2 Motor bracket Aluminum with brass cover and front scraping anti-locking function (patented)

3 Impeller Brass, radial peripheral vane type

4 Mechanical seal	Pump	Seal	Shaft	Materials
	PQ 60-61-65-80	AR-12	Ø 12 mm	Ceramic / Graphite / NBR
	PQ 90	ST1-12	Ø 12 mm	Silicon carbide / Graphite / NBR
	PQ 100-200-300	FN-14	Ø 14 mm	Graphite / Ceramic / NBR

5 Motor shaft Stainless steel **AISI 431** (EN 10088-3 - 1.4104 for PQ 60, PQ 61, PQ 65)

6 Electric motor **PQm**: single-phase 230 V - 50 Hz with winding integrated thermal motor protection.
PQ: three-phase 230/400 V - 50 Hz
※ Pumps are equipped with high-efficiency motors (IEC 60034-30-1)
class **IE2** for single-phase models
class **IE3** for three-phase models
– Continuous running duty **S1**
– Insulation: class F
– Protection rating: IP X4

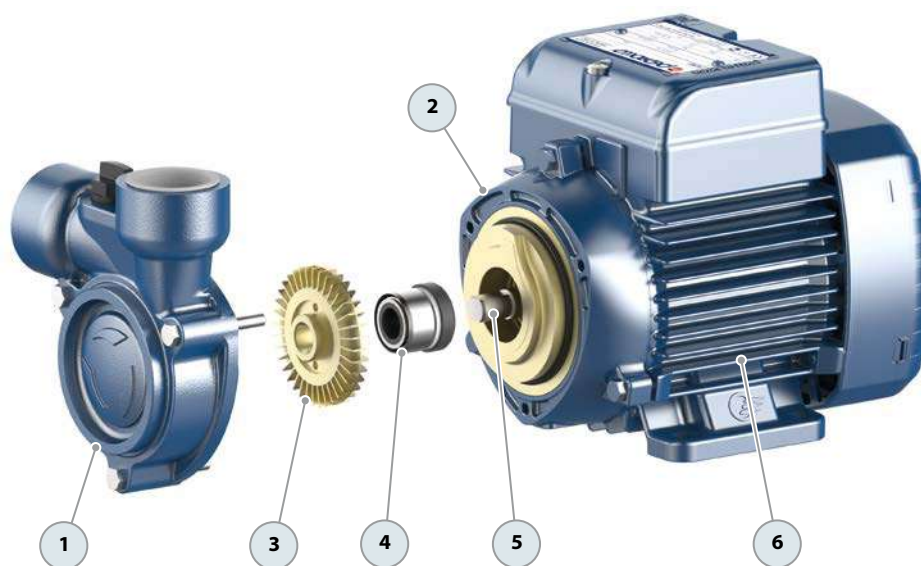



Clean water



Domestic use

- ※ New version featuring an anti-lock braking system.
- ※ Noise levels reduced by 20%.



PERFORMANCE RANGE

- Flow rate up to **50 l/min** (3.0 m³/h)
- Head up to **70 m**

INSTALLATION AND USE

Designed to transfer clean water free from abrasive particles and liquids that will not damage the pump's components.

Compact, reliable, and cost-effective, they are ideal for domestic applications when paired with small autoclave tanks, and for irrigating gardens and orchards. They are also effective in drawing water from tanks and pumping liquids that contain air or gas. The pumps come equipped with a non-return check valve for suction.

APPLICATION LIMITS

- Manometric suction head up to **9 m** (HS)
- Liquid temperature between **-10 °C** and **+60 °C**
- Ambient temperature up to **+40 °C** (**+50 °C** for PKS 60)
- Maximum working pressure:
 - **6 bar** for PKS 60, PKS 65
 - **7 bar** for PKS 80

AVAILABLE UPON REQUEST

- ※ Mechanical seal options available
- ※ Different voltage requirements 60 Hz frequency

PATENTS - TRADE MARKS - MODELS

- Motor bracket: Patent No. IT1243605

CURVES AND PERFORMANCE DATA – HS=0 m

50 Hz

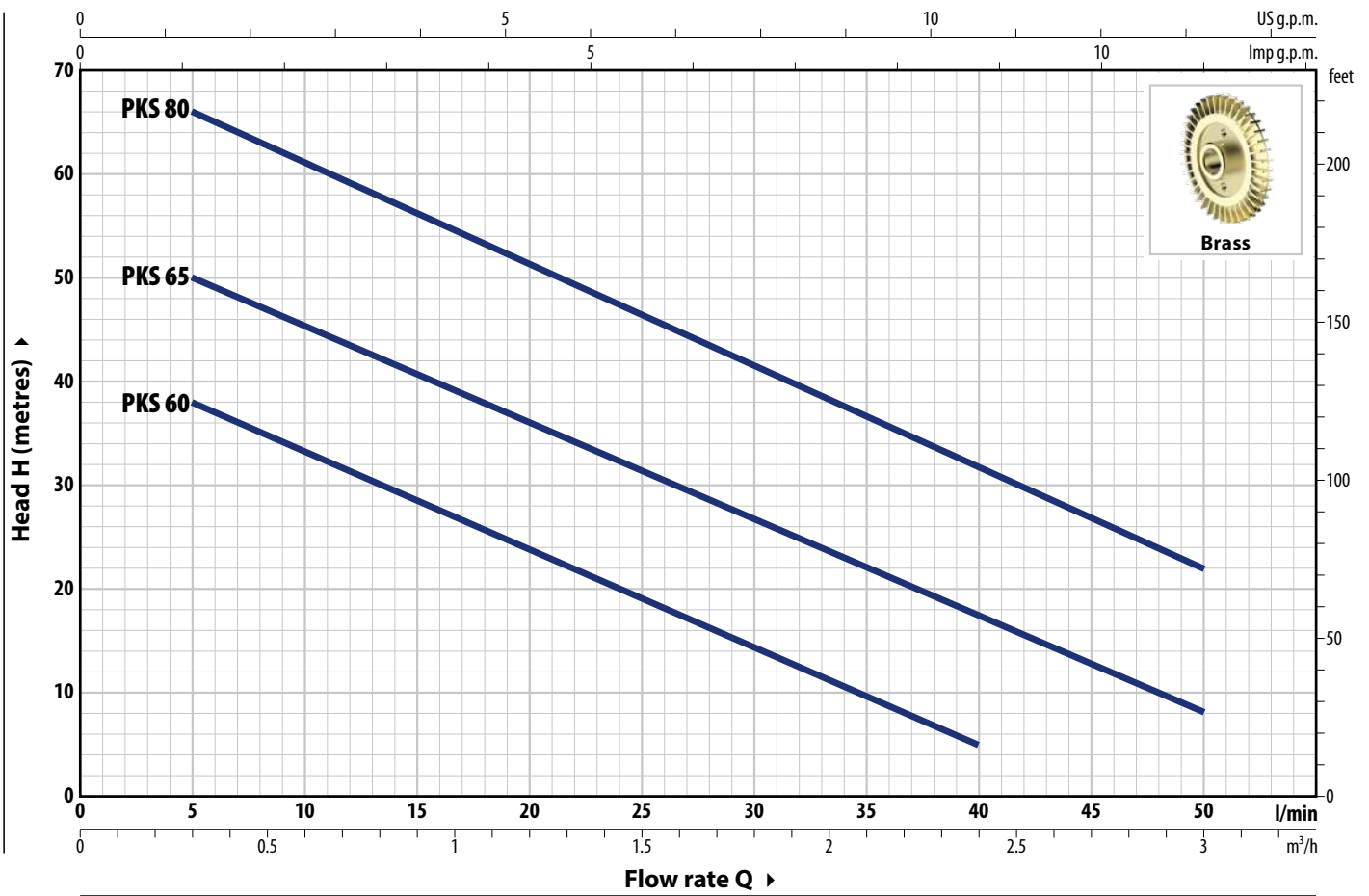

TYPE		POWER (P ₂)		1~3~	Q	m ³ /h										
Single-ph.	Three-ph.	kW	HP			0	0.3	0.6	0.9	1.2	1.5	1.8	2.1	2.4	2.7	3.0
						0	5	10	15	20	25	30	35	40	45	50
PKSm 60	PKS 60	0.30	0.40	IE2 IE3	H metres	40	38	33.5	29	24	19.5	15	10	5		
PKSm 65	PKS 65	0.55	0.75			55	50	45.5	40.5	36	31	27	22	17	12.5	8
PKSm 80	PKS 80	0.75	1			70	66	61	56	51	46	41	36.5	31	27	22

Q = Flow rate H = Total manometric head HS = Suction height

Performance curves comply with EN ISO 9906 Grade 3B tolerance limits.

EXAMPLE OF INSTALLATION

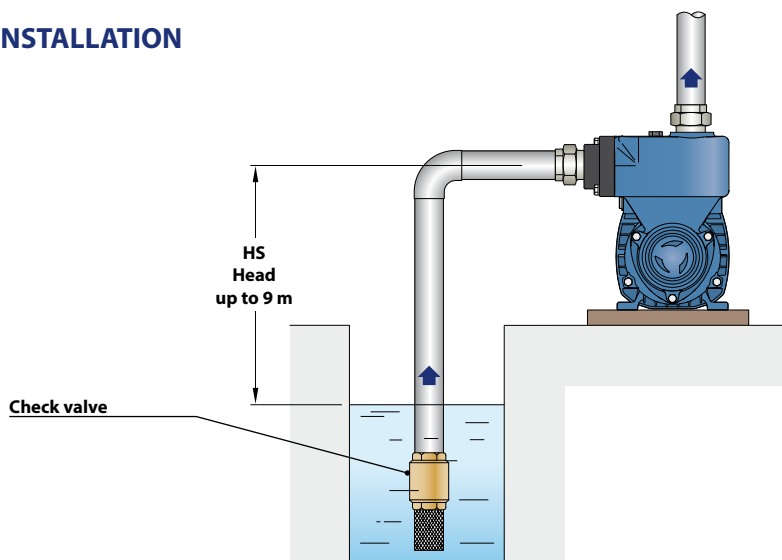

ABSORPTION

TYPE	VOLTAGE
Single-phase	230 V
PKSm 60	2.3 A
PKSm 65	3.7 A
PKSm 80	5.2 A

TYPE	VOLTAGE	
Three-phase	230 V - Δ	400 V - 人
PKS 60	2.0 A	1.15 A
PKS 65	2.9 A	1.7 A
PKS 80	3.8 A	2.2 A

DIMENSIONS AND WEIGHT

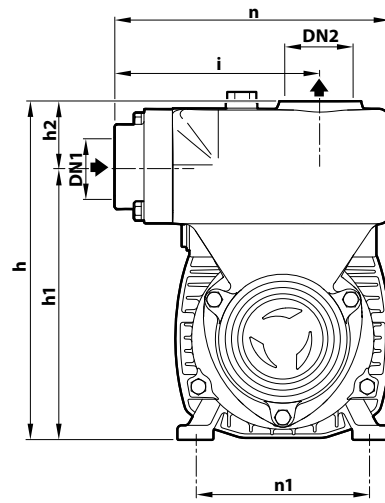
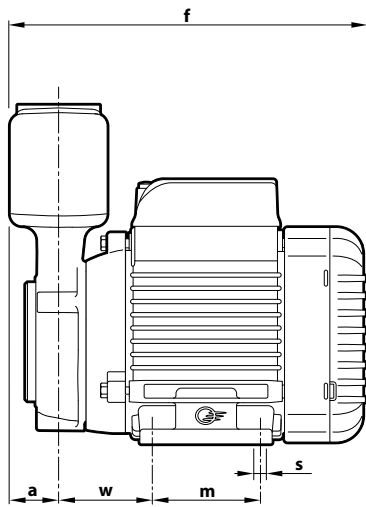

TYPE		PORTS		DIMENSIONS mm											kg	
Single-ph.	Three-ph.	DN1	DN2	a	f	h	h1	h2	i	m	n	n1	w	s	1~	3~
PKSm 60	PKS 60	1"	1"	28	196	183	149	34	110	55	148	93-100	53	7	5.6	5.6
PKSm 65	PKS 65				227	190	156			80		100			7.6	6.9
PKSm 80	PKS 80				263	198	164			90	160	112			62	10.6

PALLET CAPACITY

TYPE		NO. OF PUMPS
Single-ph.	Three-ph.	
PKSm 60	PKS 60	224
PKSm 65	PKS 65	168
PKSm 80	PKS 80	96

CONSTRUCTION FEATURES

1 Pump body Cast iron with ISO 228/1 threaded ports

2 Check valve Built-in check valve in the inlet port

3 Motor bracket Aluminum with brass cover and front scraping anti-locking function (patented)

4 Impeller Brass, radial peripheral vane type

5 Mechanical seal	Seal	Shaft	Materials
	AR-12	Ø 12 mm	Ceramic / Graphite / NBR

6 Motor shaft Stainless steel **AISI 431** (EN 10088-3 - 1.4104 for PKS 60, PKS 65)

7 Electric motor **PKSm**: single-phase 230 V - 50 Hz with winding integrated thermal motor protection.
PKS: three-phase 230/400 V - 50 Hz
 ※ Pumps are equipped with high-efficiency motors (IEC 60034-30-1)
 class **IE2** for single-phase models
 class **IE3** for three-phase models
 – Continuous running duty **S1**
 – Insulation: class F
 – Protection rating: IP X4

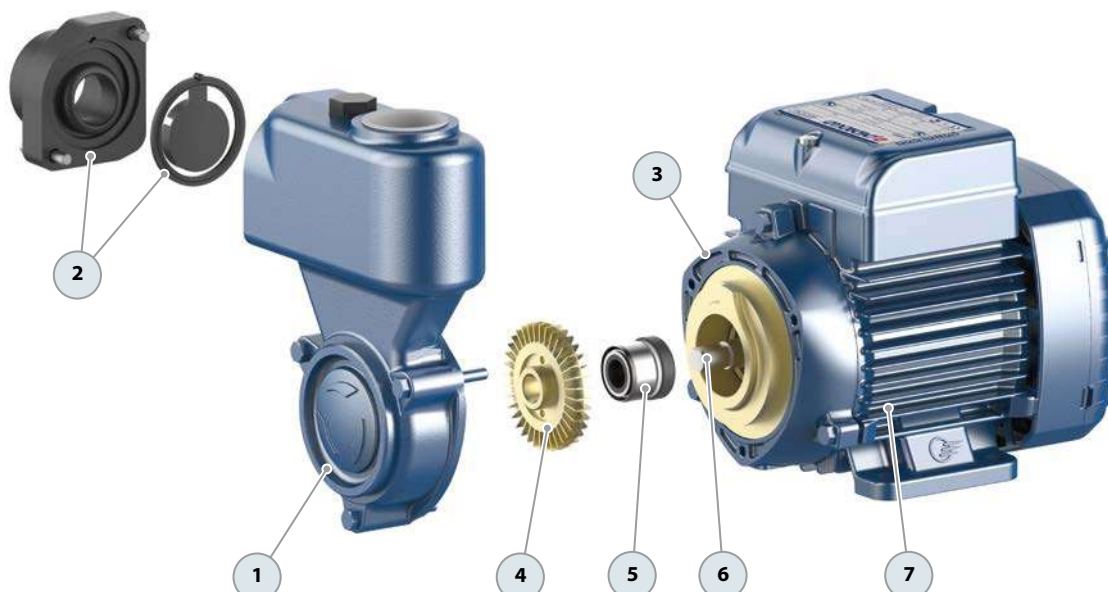



INSTALLATION AND USE

Designed for pumping diesel/naphtha and clean water free from abrasive particles and non-corrosive liquids that do not harm the pump's components.

Their specific operating mechanism makes them an excellent solution when a compact self-priming pump is required or when the flow of the liquid is irregular or mixed with air.

APPLICATION LIMITS

- Suction head up to **9 m (HS)**
- Liquid temperature between **-10 °C** and **+90 °C**
- Temperature for diesel/naphtha up to **+55 °C**
- Ambient temperature up to **+40 °C**
- Maximum working pressure **6 bar**

AVAILABLE UPON REQUEST

- ✘ Mechanical seal options available

CURVES AND PERFORMANCE DATA – HS=0 m 50 Hz

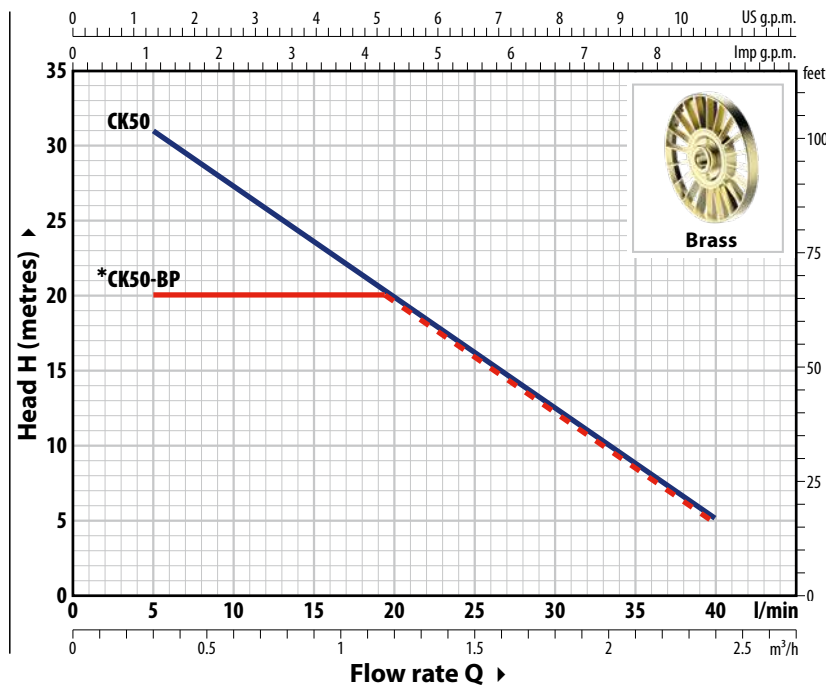

(*) CK 50-BP = performance curve with by-pass

ABSORPTION

TYPE	VOLTAGE
Single-ph.	230 V
CKm 50	3.0 A
CKm 50-BP	2.7 A

TYPE	VOLTAGE	
Three-ph.	230 V - Δ	400 V - Λ
CK 50	2.1 A	1.2 A
CK 50-BP	1.7 A	1.0 A

TYPE		POWER (P ₂)		1~	3~	Q	Flow rate													
Single-ph.	Three-ph.	kW	HP				m ³ /h	0	0.3	0.6	0.9	1.2	1.5	1.8	2.1	2.4				
CKm 50	CK 50	0.37	0.50	IE2	IE3	H metres	0	5	10	15	20	25	30	35	40					
CKm 50-BP	CK 50-BP	0.25	0.33				35	31	27	24	20	16	13	9	5					
							20	20	20	20	20	16	13	9	5					

Q = Flow rate H = Total manometric head HS = Suction height

Performance curves comply with EN ISO 9906 Grade 3B tolerance limits.

DIMENSIONS (mm)

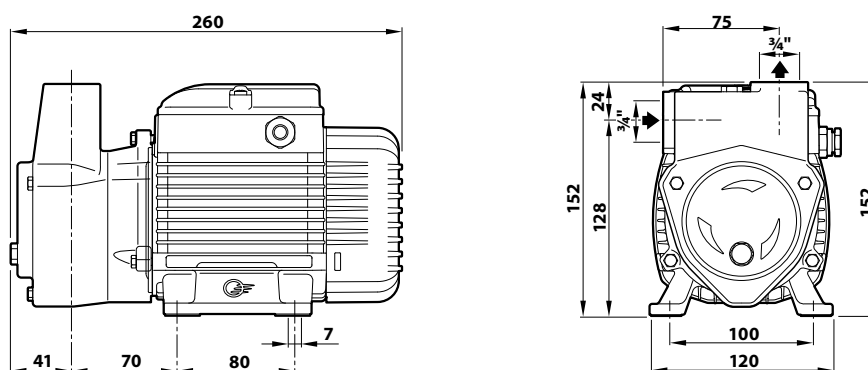

TYPE		PORTS		WEIGHT (kg)		PALLET CAPACITY
Single-phase	Three-phase	DN1	DN2	1~	3~	
CKm 50	CK 50	3/4"	3/4"	7.3	7.3	160

CONSTRUCTION FEATURES

1 Pump body	Cast iron with ISO 228/1 threaded ports	
2 Motor bracket	Aluminium with brass cover with front anti-locking shim function (patented)	
3 Impeller	Brass with open radial vanes	
4 Mechanical seal	Type	Materials
	AR-12V	Ceramic / Graphite / Viton
5 Shaft	Stainless steel AISI 431	
6 Electric motor	CKm: single-phase 230 V - 50 Hz with winding integrated thermal motor protection. CK: three-phase 230/400 V - 50 Hz ※ Pumps are equipped with high-efficiency motors (IEC 60034-30-1) class IE2 for single-phase models class IE3 for three-phase models – Continuous running duty S1 – Insulation: class F – Protection rating: IP X4	

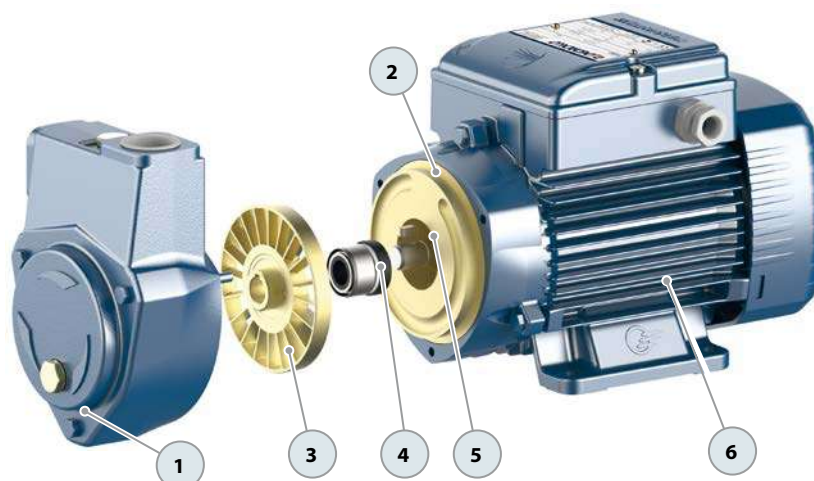



Clean water



Domestic use



Industrial use



Agricultural use

INSTALLATION AND USE

Designed for pumping diesel/naphtha and clean water free from abrasive particles and non-corrosive liquids that do not harm the pump's components.

Their specific operating mechanism makes them an excellent solution when a compact self-priming pump is required or when the flow of the liquid is irregular or mixed with air.

APPLICATION LIMITS

- Suction head up to **9 m (HS)**
- Liquid temperature between **-10 °C** and **+90 °C**
- Ambient temperature up to **+40 °C**
- Maximum working pressure **6 bar**

AVAILABLE UPON REQUEST

- ✘ Mechanical seal options available
- ✘ Specific voltages
- ✘ Protection rating: IP 55

PATENTS - TRADE MARKS - MODELS

- Motor bracket: Patent No. IT1243605



✘ With double anti-lock front scraping

CURVES AND PERFORMANCE DATA – HS=0 m

50 Hz

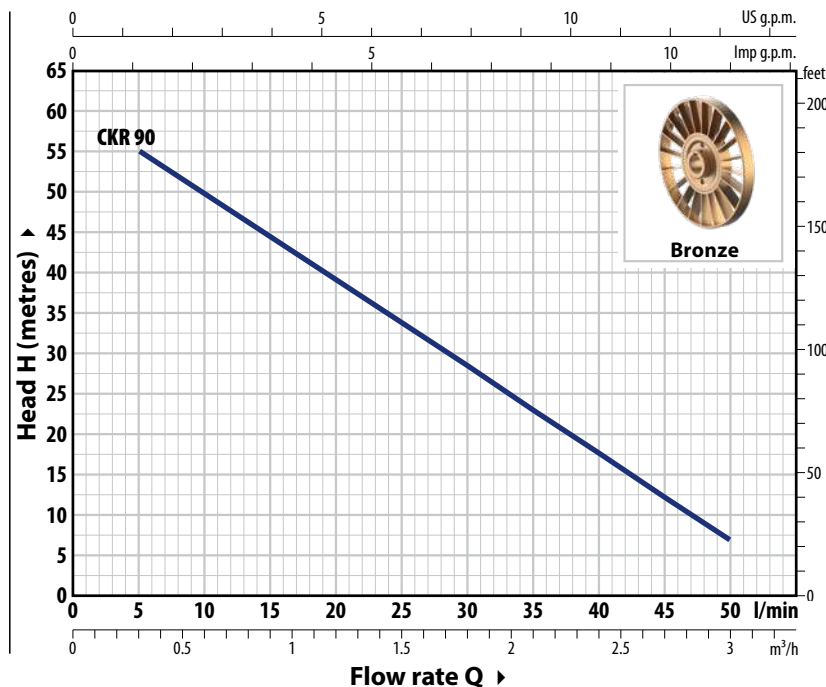

ABSORPTION

TYPE	VOLTAGE
Single-ph.	230 V
CKRm 90	5.7 A

TYPE	VOLTAGE	
Three-ph.	230 V - Δ	400 V - 人
CKR 90	4.0 A	2.3 A

TYPE		POWER (P ₂)		1~3~	Q	Flow rate												
Single-ph.	Three-ph.	kW	HP			m ³ /h	0	0.3	0.6	0.9	1.2	1.5	1.8	2.1	2.4	2.7	3.0	
					l/min	0	5	10	15	20	25	30	35	40	45	50		
CKRm 90	CKR 90	0.75	1	IE2 IE3	H metres	60	55	49.7	44.3	39	33.7	28.3	23	17.7	12.3	7		

Q = Flow rate H = Total manometric head HS = Suction height

Performance curves comply with EN ISO 9906 Grade 3B tolerance limits.

DIMENSIONS (mm)

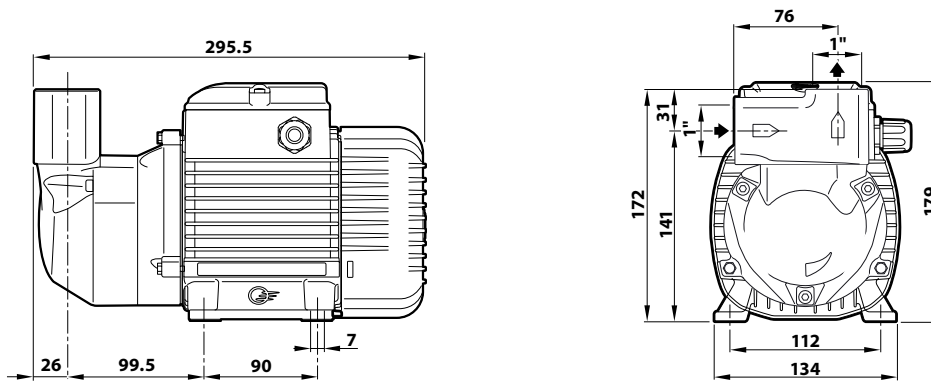

TYPE		PORTS		WEIGHT (kg)		PALLET CAPACITY
Single-phase	Three-phase	DN1	DN2	1~	3~	
CKRm 90	CKR 90	1"	1"	12.0	12.0	119

CONSTRUCTION FEATURES

1 Pump body	Cast iron, with stainless-steel front shaving surface to prevent the impeller from locking due to oxidation. The pump body is equipped with ISO 228/1 threaded ports	
2 Motor bracket	Aluminium with brass cover with front anti-locking shim function (patented)	
3 Impeller	Bronze, star-type with open radial vanes	
4 Mechanical seal	Type	Materials
	AR-12V	Ceramic / Graphite / Viton
5 Shaft	Stainless steel AISI 431	
6 Electric motor	CKRm: single-phase 230 V - 50 Hz with winding integrated thermal motor protection CKR: three-phase 230/400 V - 50 Hz ※ Pumps are equipped with high-efficiency motors (IEC 60034-30-1) class IE2 for single-phase models class IE3 for three-phase models – Continuous running duty S1 – Insulation: class F – Protection rating: IP X4	

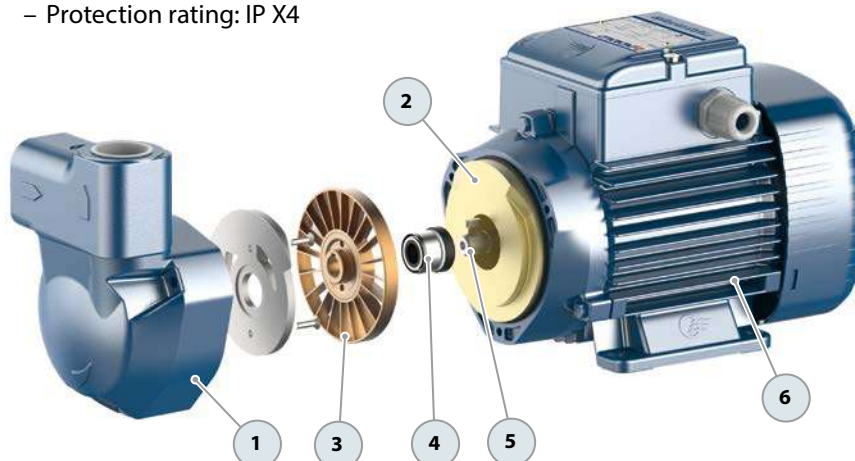



※ Electric pumps for industrial use



PERFORMANCE RANGE

- Flow rate up to **50 l/min** (3.0 m³/h)
- Head up to **95 m**

INSTALLATION AND USE

Designed for pumping diesel/naphtha and **clean water** free from abrasive particles and non-corrosive liquids that do not harm the pump's components.

Their hydraulic characteristics, compactness, and small size make them ideal for industrial applications such as chillers, air conditioners, coolers, and boiler feed systems.

PUMP BODY

The **pump body** is made of **CW617N brass**, which guarantees protection against rust and oxidation.

APPLICATION LIMITS

- Manometric suction head up to **8 m**
- Liquid temperature between **-10 °C** and **+90 °C**
- Ambient temperature between **-10 °C** and **+40 °C**
- Maximum working pressure **10 bar**

AVAILABLE UPON REQUEST

- ※ Mechanical seal options available
- ※ Protection rating IP 55 (only for PQ81-Bs and PQ65-Bs)
- ※ Different voltage requirements 60 Hz frequency

PATENTS - TRADE MARKS - MODELS

- Motor bracket: Patent No. IT1243605
- Community Model No. 009068877-0001

CURVES AND PERFORMANCE DATA – HS=0 m

50 Hz

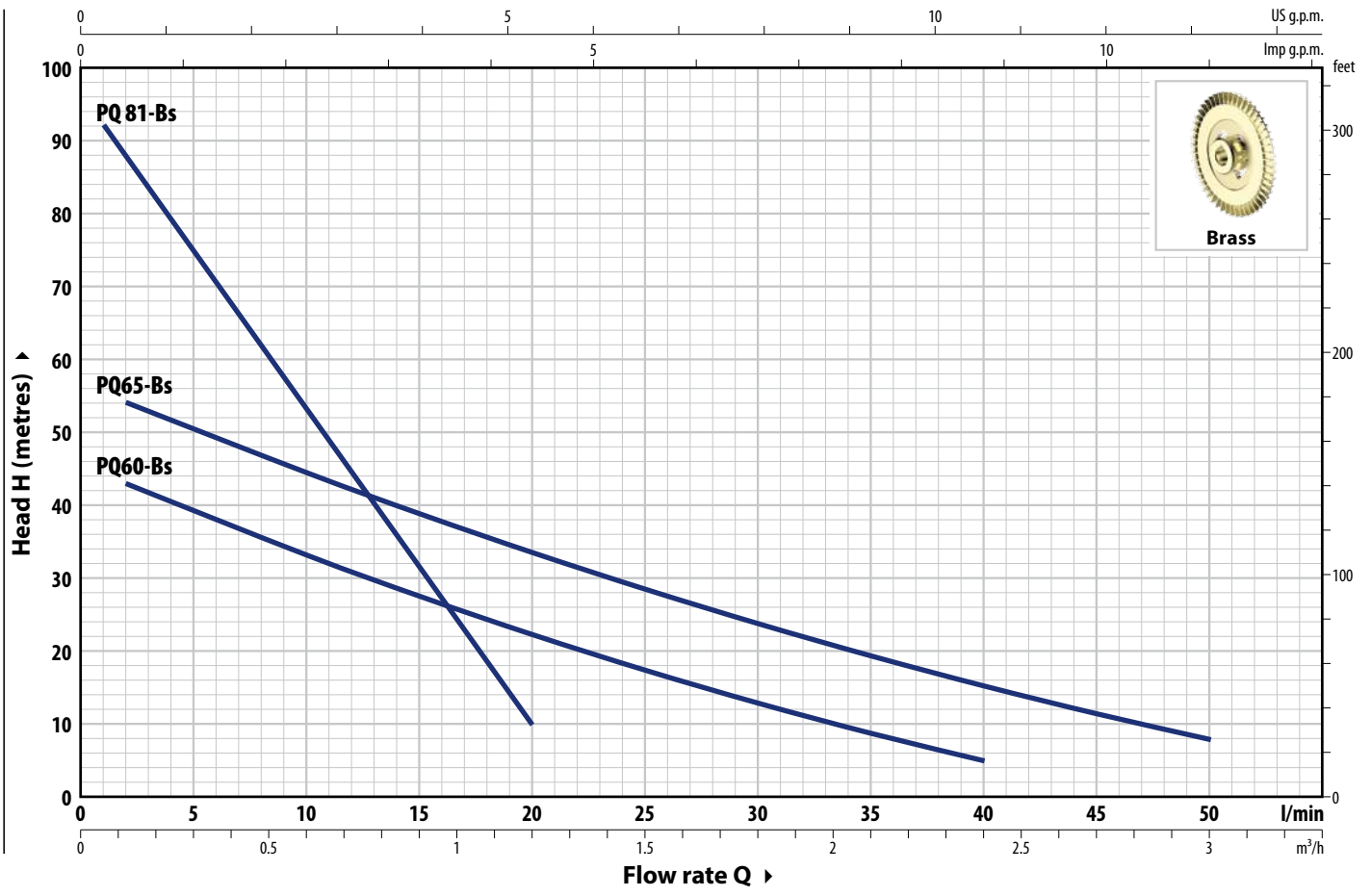

TYPE		POWER (P ₂)		1~	3~	Q	m ³ /h																
Single-ph.	Three-ph.	kW	HP				0	0.06	0.12	0.3	0.6	0.9	1.2	1.5	1.8	2.1	2.4	2.7	3.0				
							0	1	2	5	10	15	20	25	30	35	40	45	50				
PQm 60-Bs	PQ 60-Bs	0.30	0.40				45.5	–	43	39	33	27.5	22.3	17.4	12.9	8.8	5						
※ PQm 65-Bs	PQ 65-Bs	0.55	0.75	IE2	IE3	H metres	56.5	–	54	50	44.5	39	33.5	28.5	23.8	19.4	15.3	11.5	8				
PQm 81-Bs	PQ 81-Bs	0.55	0.75				95	92	87.5	75	53	31.5	10										

Q = Flow rate H = Total manometric head HS = Suction height

Performance curves comply with EN ISO 9906 Grade 3B tolerance limits.

ABSORPTION

TYPE	VOLTAGE
Single-phase	230 V
PQm 60-Bs	2.3 A
PQm 65-Bs	3.7 A
PQm 81-Bs	3.5 A

TYPE	VOLTAGE	
Three-phase	230 V - Δ	400 V - 人
PQ 60-Bs	2.0 A	1.15 A
PQ 65-Bs	2.9 A	1.7 A
PQ 81-Bs	2.4 A	1.4 A

PQ-Bs

DIMENSIONS AND WEIGHT

PQ 60-Bs

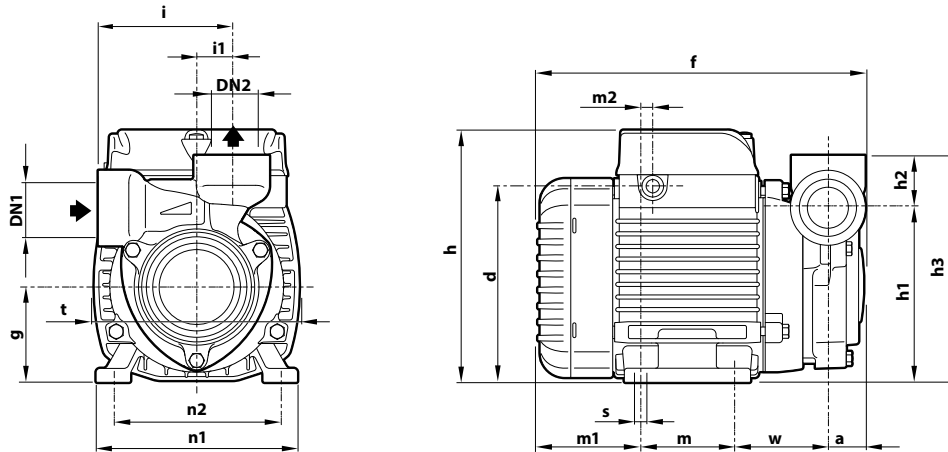

PQ 65-Bs – PQ 81-Bs

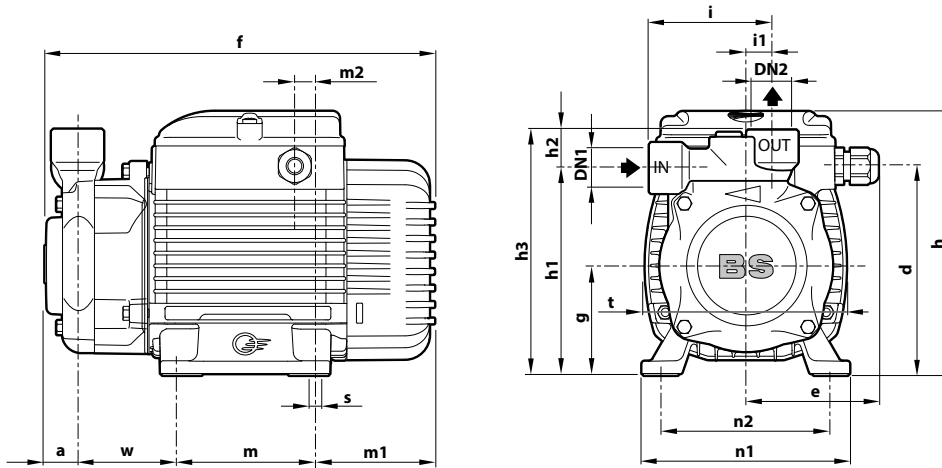

TYPE		PORTS		DIMENSIONS mm																	kg				
Single-ph.	Three-ph.	DN1	DN2	a	d	e	f	g	h	h1	h2	h3	i	i1	m	m1	m2	n1	n2	t	w	s	1~	3~	
PQm 60-Bs	PQ 60-Bs	3/4"	3/4"	21.5	112	-	192	56	145.5	101		131			55	62	8	116		118			5.0	5.0	
PQm 65-Bs	PQ 65-Bs			24		226				108		30	138		76	20				100		53.5		7	7.0
PQm 81-Bs	PQ 81-Bs	1/2"	1/2"	18	119.5	76.5	223	63	153	119	22	141	71	15	80	69	8.5	120		117		55		6.9	6.9

PALLET CAPACITY

TYPE		NO. OF PUMPS
Single-ph.	Three-ph.	
PQm 60-Bs	PQ 60-Bs	238
PQm 65-Bs	PQ 65-Bs	216
PQm 81-Bs	PQ 81-Bs	160

CONSTRUCTION FEATURES

1 Pump body	Brass with ISO 228/1 threaded ports	
2 Motor bracket	Aluminium with brass cover with anti-lock front shim function (patented)	
3 Impeller	Brass, radial peripheral vane type	
4 Mechanical seal	Type	Materials
	ST1-12	Silicon carbide / Graphite / NBR
5 Motor shaft	Stainless steel AISI 431	
6 Electric motor	<p>PQm-Bs: single-phase 230 V - 50 Hz with winding integrated thermal motor protection</p> <p>PQ-Bs: three-phase 230/40 V - 50 Hz</p> <p>※ Pumps are equipped with high-efficiency motors (IEC 60034-30-1)</p> <p>class IE2 for single-phase models</p> <p>class IE3 for three-phase models</p> <ul style="list-style-type: none"> - Continuous running duty S1 - Insulation: class F - Protection rating: IP X4 	

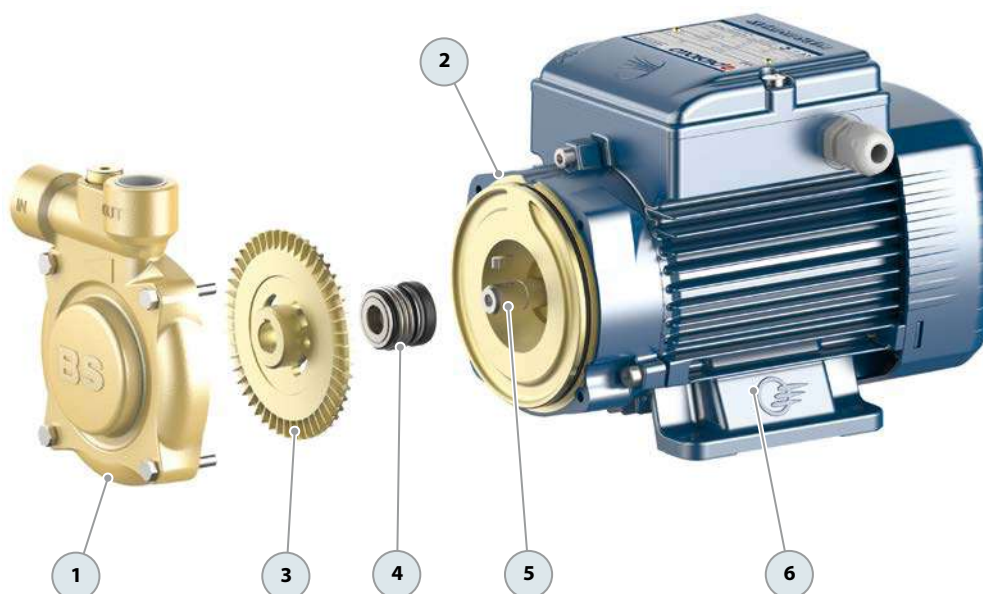

PQ 81-PPS

Peripheral pump with PPS pump body



INSTALLATION AND USE

Designed to transfer clean water free from abrasive particles and liquids that will not damage the pump's components.

Its hydraulic characteristics and compactness make it suitable for **industrial applications**.

PUMP BODY

The material used for the **pump body** is a **PPS-based** technopolymer reinforced with glass fibre, which gives it excellent mechanical properties.

APPLICATION LIMITS

- Manometric suction head up to **8 m**
- Liquid temperature between **-10 °C** and **+90 °C**
- Ambient temperature between **-10 °C** and **+40 °C**
- Maximum working pressure **10 bar**

AVAILABLE UPON REQUEST

- ✘ Mechanical seal options available
- ✘ IP 55 protection rating
- ✘ Different voltage requirements 60 Hz frequency



✘ Pump for industrial use

CURVES AND PERFORMANCE DATA – HS=0 m

50 Hz

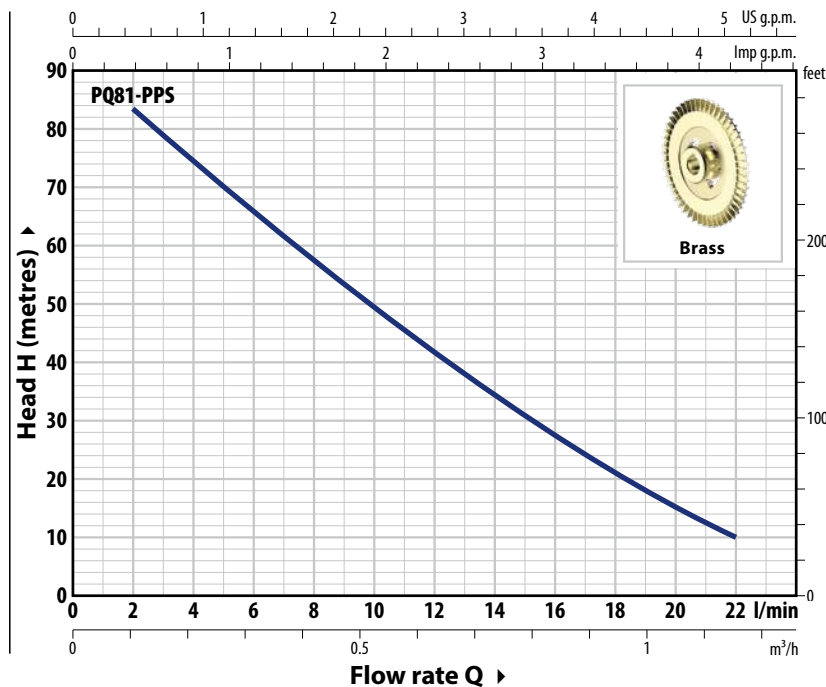

ABSORPTION

TYPE	VOLTAGE	
Single-phase	230 V	
PQm 81-PPS	3.5 A	

TYPE	VOLTAGE	
Three-phase	230 V - Δ	400 V - ㄩ
PQ 81-PPS	2.4 A	1.4 A

TYPE		POWER (P ₂)		1~3~	Q	Flow rate												
Single-ph.	Three-ph.	kW	HP			m³/h	0	0.12	0.24	0.36	0.48	0.60	0.72	0.84	0.96	1.08	1.2	1.32
PQm 81-PPS	PQ 81-PPS	0.55	0.75	IE2 IE3	H metres	90	83.5	74.5	66.5	57.5	49	41	35	28	22	15	10	

Q = Flow rate H = Total manometric head HS = Suction height

Performance curves comply with EN ISO 9906 Grade 3B tolerance limits.

DIMENSIONS (mm)

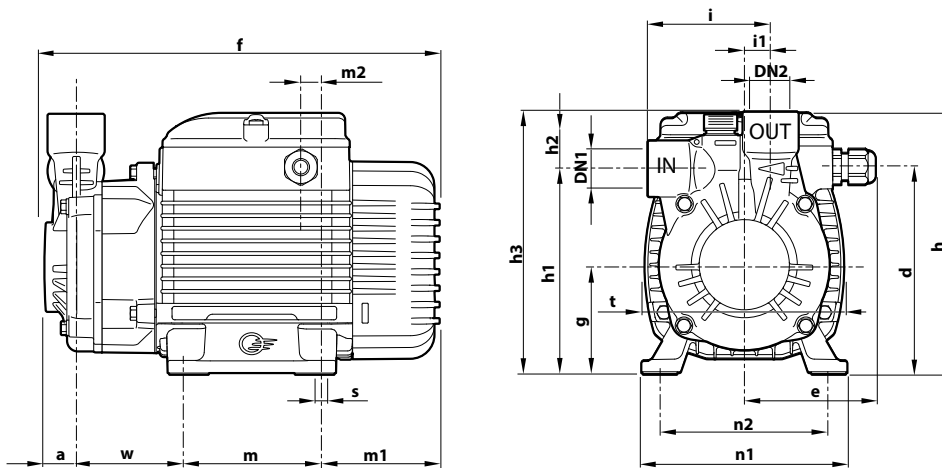

TYPE		PORTS		DIMENSIONS mm																	kg			
Single-phase	Three-phase	DN1	DN2	a	d	e	f	g	h	h1	h2	h3	i	i1	m	m1	m2	n1	n2	t	w	s	1~	3~
PQm 81-PPS	PQ 81-PPS	½"	½"	18.5	119.5	76.5	223	63	163	119	33	152	71	15	80	69	8.5	120	100	117	61	7	6.5	6.5

CONSTRUCTION FEATURES

1 Pump body	PPS , with ISO 228/1 threaded brass inserted in ports	
2 Motor bracket	Aluminium with brass cover with front anti-locking shim function	
3 Impeller	Brass	
4 Mechanical seal	Type	Materials
	ST1-12	Silicon carbide / Graphite / NBR
5 Shaft	Stainless steel AISI 431	
6 Electric motor	<p>PQm-PPS: single-phase 230 V - 50 Hz with winding integrated thermal motor protection.</p> <p>PQ-PPS: three-phase 230/40 V - 50 Hz</p> <p>※ Pumps are equipped with high-efficiency motors (IEC 60034-30-1)</p> <ul style="list-style-type: none"> class IE2 for single-phase models class IE3 for three-phase models <ul style="list-style-type: none"> – Continuous running duty S1 – Insulation: class F – Protection rating: IP X4 	

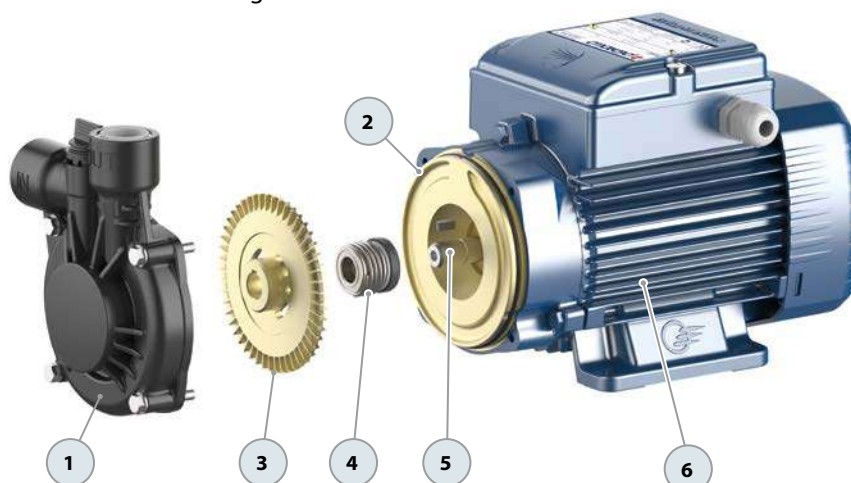



INSTALLATION AND USE

The **PQA** electric pumps are designed to transfer clean water free from abrasive particles and non-corrosive liquids that do not harm the pump's components. Made from PPS with a brass impeller front cover, ensuring protection against rust and oxidation, they are suited for various industrial applications, such as cooling, air conditioning, and ironing systems.

APPLICATION LIMITS

- Manometric suction head up to **8 m**
- Liquid temperature between **-10 °C** and **+90 °C**
- Ambient temperature between **-10 °C** and **+40 °C** (+50 °C for PQA 60)
- Maximum working pressure **10 bar**

AVAILABLE UPON REQUEST

- ✘ Mechanical seal options available
- ✘ Shaft in AISI 316 stainless steel - EN 10088-3 - 1.4401
- ✘ Protection rating IP X5 for PQA 70-90
- ✘ Different voltage requirements 60 Hz frequency

PATENTS - TRADE MARKS - MODELS

- Motor bracket: Patent No. IT1243605
- Shaft: Patent No. 0000275945 (PQA 50)

CURVES AND PERFORMANCE DATA – HS=0 m 50 Hz

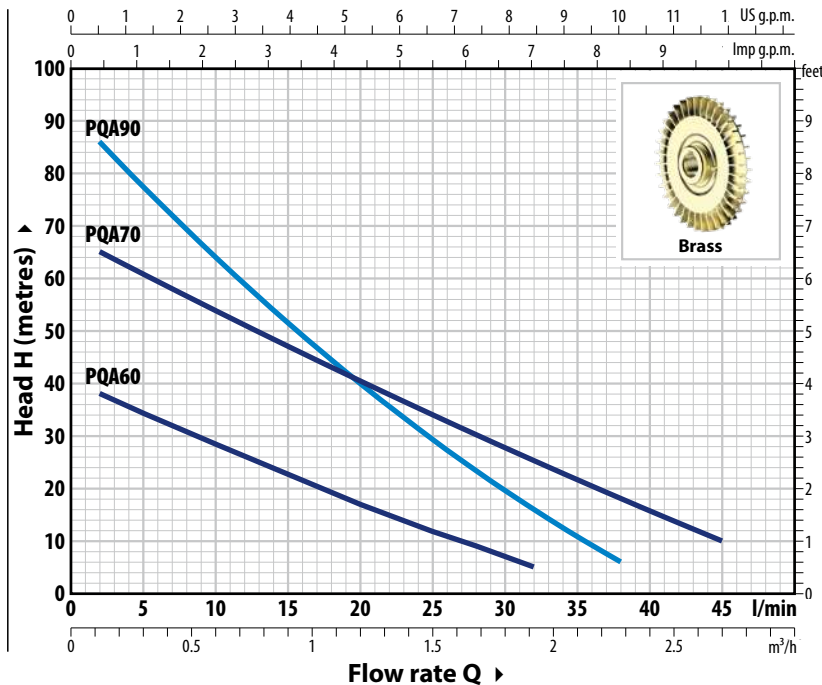

ABSORPTION

TYPE	VOLTAGE	
Single-ph.	230 V	
PQAm 60	2.3 A	
PQAm 70	6.2 A	
PQAm 90	5.6 A	

TYPE	VOLTAGE	
Three-ph.	230 V - Δ	400 V - 人
PQA 60	2.0 A	1.15 A
PQA 70	4.2 A	2.4 A
PQA 90	4.2 A	2.4 A

TYPE		POWER (P ₂)		1~3~	Q	Flow rate														
Single-phase	Three-phase	kW	HP			m ³ /h	0	0.12	0.3	0.6	0.9	1.2	1.5	1.68	1.8	1.92	2.28	2.46	2.7	
PQAm 60	PQA 60	0.30	0.40		l/min	0	2	5	10	15	20	25	28	30	32	38	41	45		
PQAm 70	PQA 70	0.55	0.75	IE2 IE3	H metres	40.5	38	34	28	22.5	17	11.8	8.8	6.9	5					
PQAm 90	PQA 90	0.75	1			68	65	61	54	47	40.5	34	30	27.5	25.3	18.1	14.6	10		
						92	86	78	64	51.5	40	29.5	23.4	19.6	16	6				

Q = Flow rate H = Total manometric head HS = Suction height

Performance curves comply with EN ISO 9906 Grade 3B tolerance limits.

DIMENSIONS AND WEIGHT

PQA 60

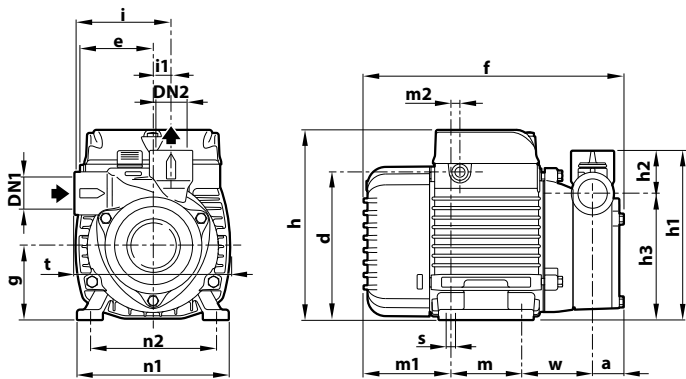

PQA 70, PQA 90

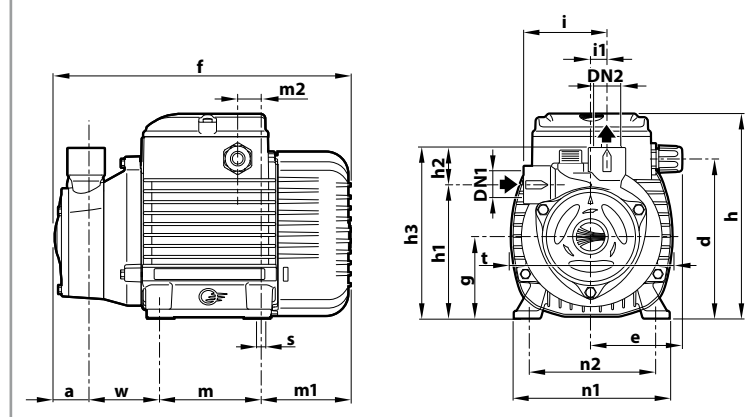

TYPE		PORTS		DIMENSIONS mm																	kg			
Single-ph.	Three-ph.	DN1	DN2	a	d	e	f	g	h	h1	h2	h3	i	i1	m	m1	m2	n1	n2	t	w	s	1~	3~
PQAm 60	PQA 60	1/2"	1/2"	23	112	55.5	196	56	145	96	33	129	72.5	13.5	55	65	8	116	97	117	53	7	4.6	4.6
PQAm 70	PQA 70			28	139	79	261	71	179	116.5	32.5	149			90	80.5	22	134	112	142	62.5		9.6	9.6
PQAm 90	PQA 90			26.5			260			121	35	156	76	16						62				9.7

PALLET CAPACITY

TYPE		NO. OF PUMPS
Single-ph.	Three-ph.	
PQAm 60	PQA 60	238
PQAm 70	PQA 70	102
PQAm 90	PQA 90	102

CONSTRUCTION FEATURES

1 Pump body	PPS, with ISO 228/1 threaded metal inserted in ports
2 Cover	Brass
3 Motor bracket	Aluminium with brass cover with front anti-locking shim function (patented)
4 Impeller	Brass, radial peripheral vane type
5 Mechanical seal	Type: ST1-12 Materials: Silicon carbide / Graphite / NBR
6 Motor shaft	Stainless steel AISI 431
7 Electric motor	<p>PQAm: single-phase 230 V - 50 Hz with winding integrated thermal motor protection.</p> <p>PQA: three-phase 230/400 V - 50 Hz</p> <p>※ Pumps are equipped with high-efficiency motors (IEC 60034-30-1)</p> <p>class IE2 for single-phase models</p> <p>class IE3 for three-phase models</p> <ul style="list-style-type: none"> – Continuous running duty S1 – Insulation: class F – Protection rating: IP X4

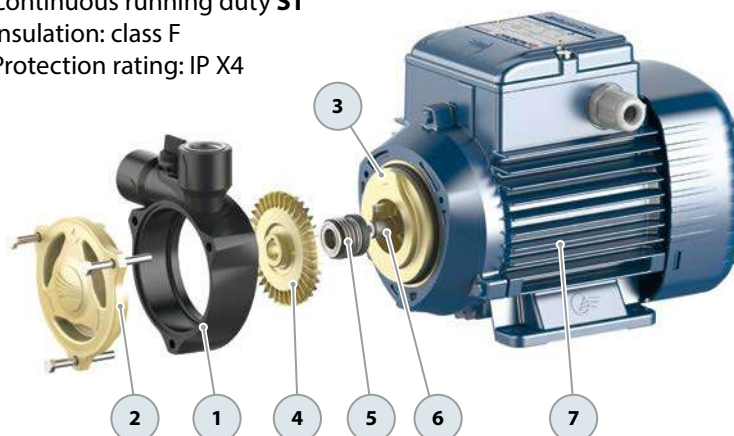



Clean water



Industrial use



PERFORMANCE RANGE

- Flow rate up to **45 l/min** (2.7 m³/h)
- Head up to **105 m**

INSTALLATION AND USE

Designed to transfer clean water free from abrasive particles and liquids that will not damage the pump's components.

The construction features of these compact brass pumps ensure protection against rust and oxidation and are suited for various industrial applications, such as **cooling and air conditioning**.

ELECTRIC MOTOR

Equipped with cutting-edge electric motors, the three-phase pumps are designed to work with inverters, offering stable and noiseless performance.

They feature efficiency class **IE3** for three-phase motors and **IE2** for single-phase motors, bolstered by class F insulation and IPX4 protection.

APPLICATION LIMITS

- Manometric suction head up to **8 m**
- Liquid temperature between **-10 °C** and **+90 °C**
- Ambient temperature between **-10 °C** and **+50 °C**
- Maximum working pressure **10 bar**

AVAILABLE UPON REQUEST

- ✘ Mechanical seal options available
- ✘ Protection rating IP X5 for PV70-90
- ✘ Different voltage requirements 60 Hz frequency

✘ **The pump body can be rotated**

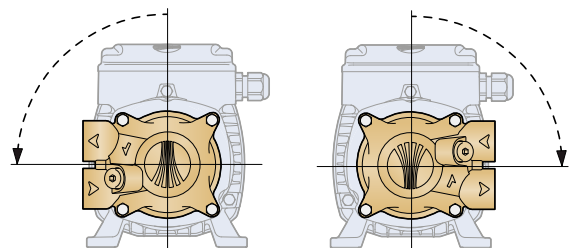

CURVES AND PERFORMANCE DATA – HS=0 m

50 Hz

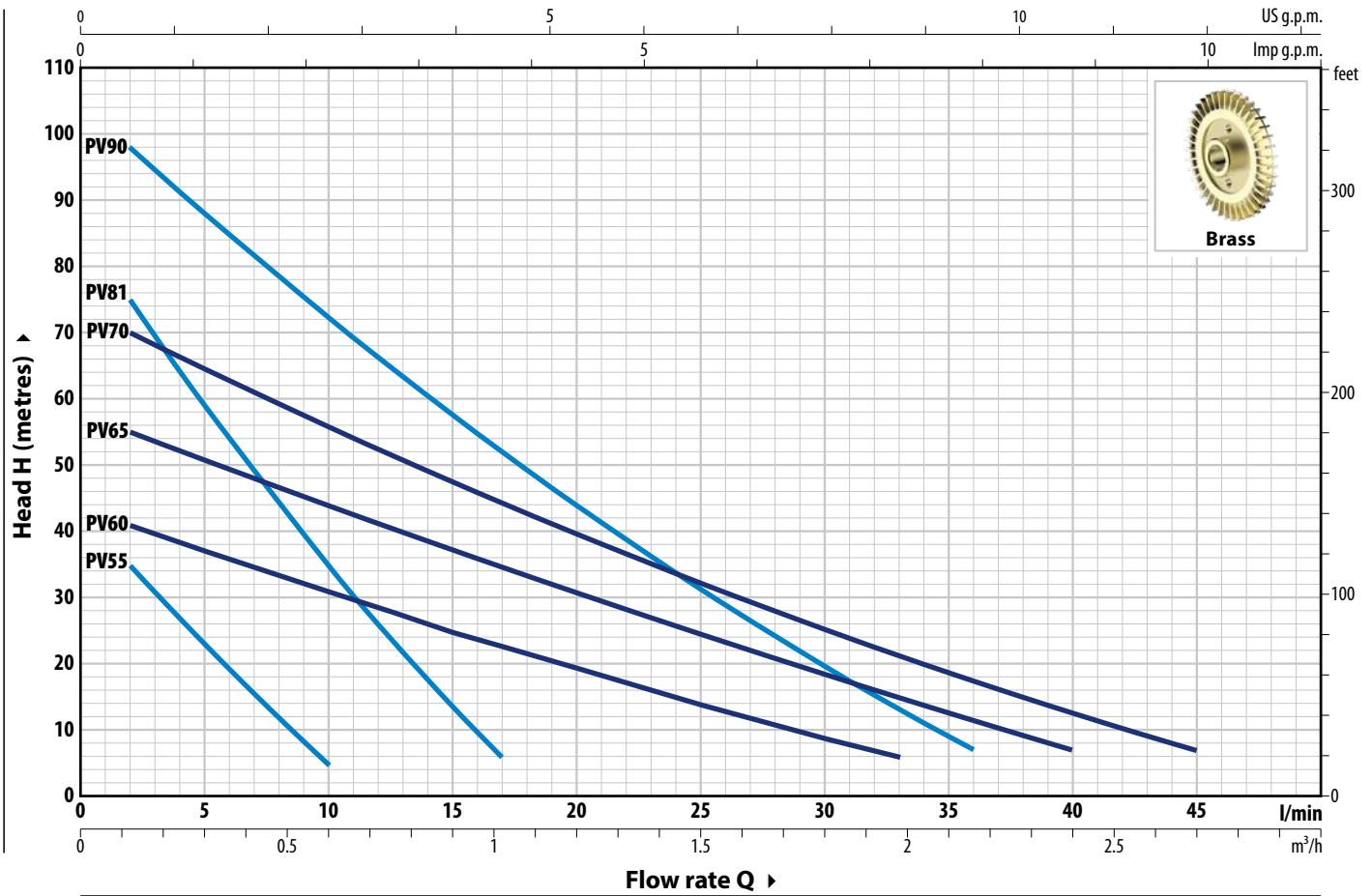

TYPE		POWER (P ₂)		Q		Q													
Single-ph.	Three-ph.	kW	HP	1~	3~	m ³ /h	0	0.12	0.18	0.24	0.3	0.36	0.42	0.48	0.54	0.6	0.66	0.72	
						l/min	0	2	3	4	5	6	7	8	9	10	11	12	
PVm 55	PV 55	0.18	0.25	IE2	IE3	H metres	50 Hz	43	35	31	27	23.2	19.4	15.7	12	8.5	5		
							60 Hz	56	46	41	36.5	32	27.5	23.4	19.4	15.5	11.9	8.3	5

✘ The Pvm55 and PV55 pump is designed to operate at 50 and 60 Hz

TYPE		POWER (P ₂)		Q		Q														
Single-ph.	Three-ph.	kW	HP	1~	3~	m ³ /h	0	0.12	0.3	0.6	0.9	1.02	1.2	1.5	1.8	1.98	2.16	2.4	2.7	
						l/min	0	2	5	10	15	17	20	25	30	33	36	40	45	
PVm 60	PV 60	0.37	0.50			H metres	44	41	37	31	25	22.7	19.4	14	8.9	6				
PVm 81	PV 81	0.37	0.50				86	75	59	35	13.7	6								
PVm 65	PV 65	0.55	0.75	IE2	IE3	H metres	58	55	51	44	37	34.5	31	24.5	18.5	14.9	11.5	7		
PVm 70	PV 70	0.75	1				74	70	64.5	56	47.5	44.5	39.5	32	25.3	21.3	17.5	12.7	7	
PVm 90	PV 90	0.75	1				105	98	88	72.5	57.5	52	44	31	19.6	13.1	7			

Q = Flow rate H = Total manometric head HS = Suction height

Performance curves comply with EN ISO 9906 Grade 3B tolerance limits.

ABSORPTION

TYPE	VOLTAGE
Single-phase	230 V
PVm 55 (50 Hz)	1.6 A
PVm 55 (60 Hz)	2.0 A
PVm 60	2.8 A
PVm 81	3.0 A
PVm 65	4.4 A
PVm 70	6.3 A
PVm 90	6.3 A

TYPE	VOLTAGE	
Three-phase	230 V - Δ	400 V - Ǝ
PV 55 (50 Hz)	1.5 A	0.9 A
PV 55 (60 Hz)	1.2 A	0.7 A
PV 60	2.1 A	1.2 A
PV 81	2.1 A	1.2 A
PV 65	2.6 A	1.5 A
PV 70	4.2 A	2.4 A
PV 90	4.2 A	2.4 A

DIMENSIONS AND WEIGHT

PV 55

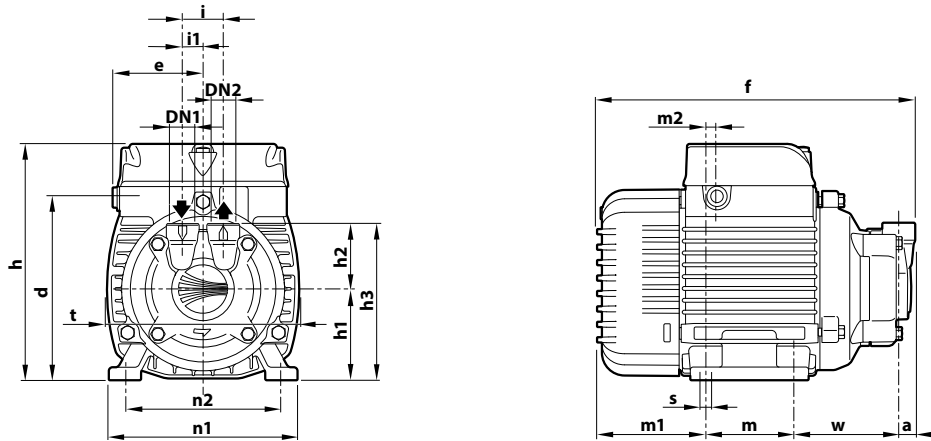

PV 60-81-65-70-90

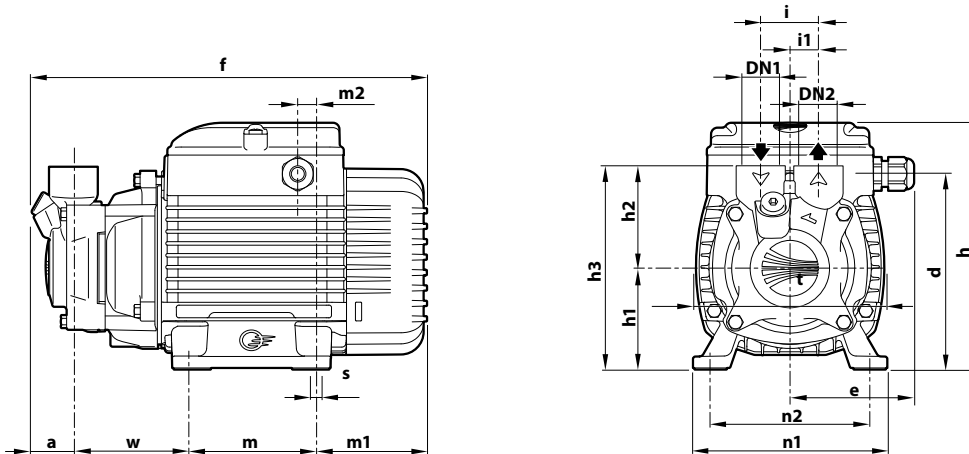

TYPE		PORTS		DIMENSIONS mm																kg				
Single-ph.	Three-ph.	DN1	DN2	a	d	e	f	h	h1	h2	h3	i	i1	m	m1	m2	n1	n2	t	w	s	1~	3~	
PVm 55	PV 55	1/4"	1/4"	10.5	112	55.5	194	145	56	40	96	25	12.5	55	65.5	8	116	94/100	116	63	7	4.4	4.3	
PVm 60	PV 60	1/2"	1/2"	26			243.5			62	125									68		5.5	5.4	
PVm 81	PV 81			26.5	120.5	76	241	152	63	65	128	35	17.5	80	69.5	11.5	120	98/102	116	65		7	6.9	6.9
PVm 65	PV 65	3/4"	3/4"	27			243.5			66	129	45								67		6.7	6.7	
PVm 70	PV 70			26.5	139	79	276	180	71	66	137	45	22.5	90	80.5	22	134	110/114	141	79			10.2	9.7
PVm 90	PV 90			28			275														76.5			10.0

(*) h=196 mm for single-phase 110 V versions

CONSTRUCTION FEATURES

1 Pump body	Brass, equipped with ISO 228/1 threaded ports		
2 Seal cover	Brass		
3 Motor bracket	Aluminum		
4 Impeller	Brass, radial peripheral vane type		
5 Mechanical seal	Type	Shaft	Materials
	ST1-12	Ø 12 mm	Silicon carbide / Graphite / NBR
6 Motor shaft	Stainless steel AISI 431		
7 Electric motor	<p>PVm: single-phase 230 V - 50 Hz (50/60 Hz for PVm55) with winding integrated thermal motor protection.</p> <p>PV: three-phase 230/400 V - 50 Hz (50/60 Hz for PV55).</p> <p>※ Pumps are equipped with high-efficiency motors (IEC 60034-30-1) class IE2 for single-phase models class IE3 for three-phase models</p> <p>Continuous running duty S1</p>		

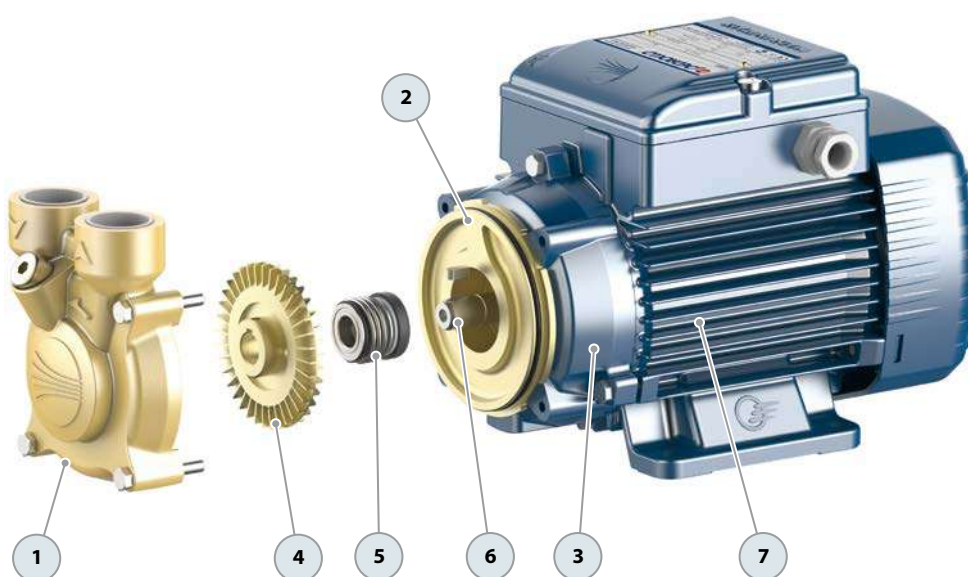

PQ 3000

Peripheral impeller pumps



INSTALLATION AND USE

- Designed to transfer clean water free from abrasive particles and liquids that will not damage the pump's components.
- Its hydraulic characteristics make it suitable for **industrial applications**.
- **PQ3000** pump's body is available in cast iron (cost-effective) or micro-cast stainless steel.

APPLICATION LIMITS

- Manometric suction head up to **8 m**
- Liquid temperature between **-10 °C** and **+90 °C**
- Ambient temperature between **-10 °C** and **+50 °C**
- Maximum working pressure **18 bar**

AVAILABLE UPON REQUEST

- ✘ Mechanical seal options available
- ✘ Shaft in stainless steel AISI 316 EN 10088-3 - 1.4401
- ✘ Different voltage requirements 60 Hz frequency

PATENTS - TRADE MARKS - MODELS

- Registered community model
No. 002714469 for PQ 3000-MF



PQ 3000
(cast iron)

PQ 3000-MF
(Stainless steel)

CURVES AND PERFORMANCE DATA – HS=0 m 50 Hz

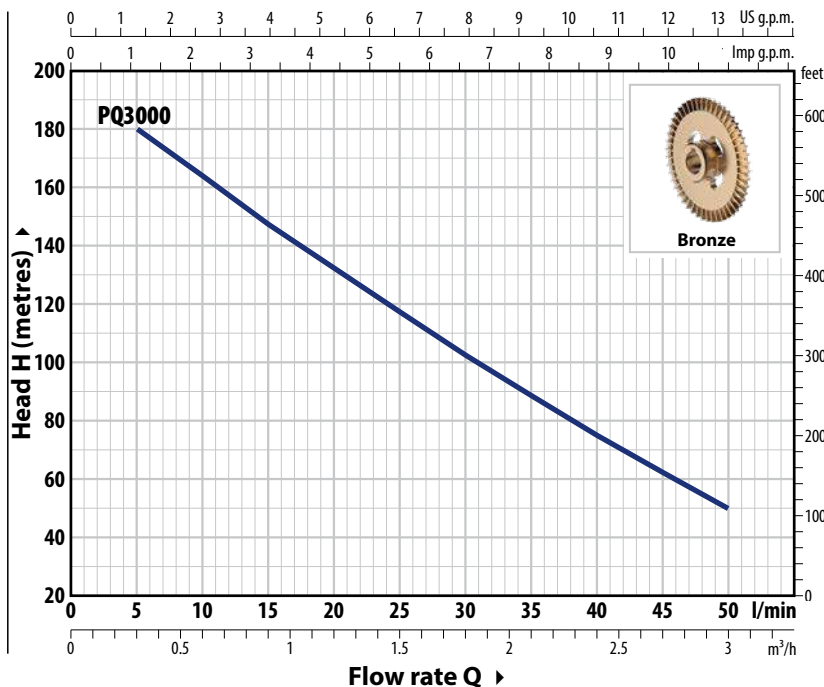

ABSORPTION

TYPE	VOLTAGE	
	230 V - Δ	400 V - 人
PQ 3000	12.9 A	7.5 A
PQ 3000-MF	12.9 A	7.5 A

TYPE	POWER (P ₂)		3~	Q	H metres									
	kW	HP			m³/h	0.3	0.6	0.9	1.2	1.5	1.8	2.1	2.4	2.7
Three-phase				l/min	5	10	15	20	25	30	35	40	45	50
PQ 3000	2.2	3	IE3		180	164	148	132	117	103	89	75.5	62.5	50
PQ 3000-MF	2.2	3			180	164	148	132	117	103	89	75.5	62.5	50

Q = Flow rate H = Total manometric head HS = Suction height

Performance curves comply with EN ISO 9906 Grade 3B tolerance limits.

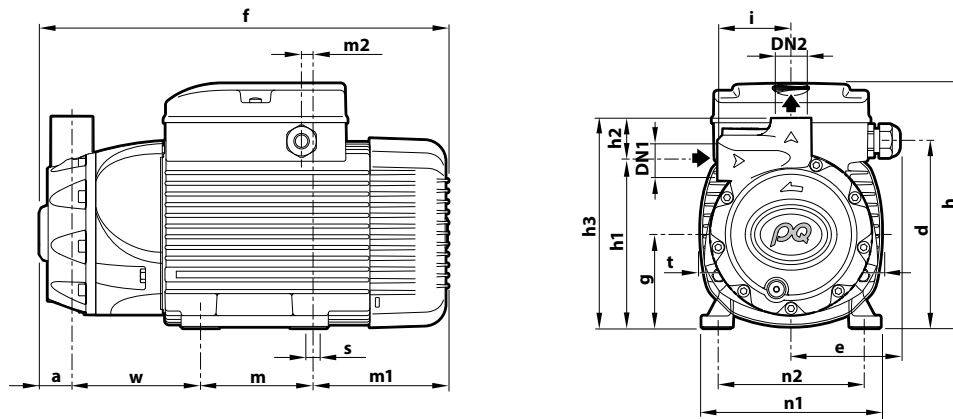

TYPE	PORTS		DIMENSIONS mm																	kg	PALLET CAPACITY		
	DN1	DN2	a	d	e	f	g	h	h1	h2	h3	i	m	m1	m2	n1	n2	t	w			s	3~
Three-phase																							
PQ 3000	¾"	¾"	37	157.5	92	356	80	211	142	36	178	62	100	114	11	151	125	155	105	9	19.9	72	
PQ 3000-MF			28		347	19.1															72		

CONSTRUCTION FEATURES

- | | | | | | |
|--------------------------|--|------|-----------|-----------------|------------------------|
| 1 Pump body | <ul style="list-style-type: none"> ✘ PQ 3000: cast iron with anti-blocking treatment with ISO 228/1 threaded ports ✘ PQ 3000-MF: stainless steel AISI 316 with ISO 228/1 threaded ports | | | | |
| 2 Cover seal | Stainless steel AISI 316 | | | | |
| 3 Motor bracket | Aluminum | | | | |
| 4 Impeller | Bronze , radial peripheral vane type | | | | |
| 5 Mechanical seal | <table border="0"> <tr> <td>Type</td> <td>Materials</td> </tr> <tr> <td>FN-18 NU</td> <td>Graphite/ Ceramic/ NBR</td> </tr> </table> | Type | Materials | FN-18 NU | Graphite/ Ceramic/ NBR |
| Type | Materials | | | | |
| FN-18 NU | Graphite/ Ceramic/ NBR | | | | |
| 6 Motor shaft | Stainless steel AISI 431 | | | | |
| 7 Electric motor | Three-phase 230/400 V - 50 Hz
<ul style="list-style-type: none"> ✘ The pumps are equipped with motors (IEC 60034-30-1) in class IE3 - Continuous running duty S1 - Insulation: class F - Protection rating: IP X5 | | | | |

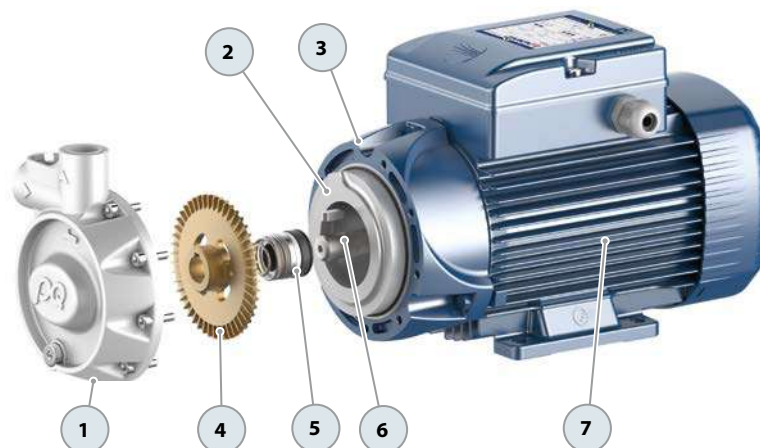

-  Clean water
-  Domestic use
-  Agricultural use
-  Industrial use

※ Centrifugal pumps made entirely of Stainless Steel



CP-ST4

- ※ Pump body: **AISI 304 stainless steel**
- ※ Rotor: **AISI 304 stainless steel**
- ※ Shaft: **AISI 431 stainless steel**

CP-ST6

- ※ Pump body: **AISI 316L stainless steel**
- ※ Rotor: **AISI 316L stainless steel**
- ※ Shaft: **AISI 316L stainless steel**

PERFORMANCE RANGE

- Flow rate up to **270 l/min** (16.2 m³/h)
- Head up to **45 m**

INSTALLATION AND USE

Designed to transfer clean water free from abrasive particles and liquids that will not damage the pump's components.

Thanks to their construction features, these centrifugal pumps are suited for domestic, agricultural, and industrial applications.

All components in contact with the pumped liquid are made of AISI 304 or AISI 316L stainless steel, ensuring total hygiene and maximum corrosion resistance.

ELECTRIC MOTOR

Equipped with cutting-edge electric motors, the three-phase pumps are designed to work with inverters, offering stable and noiseless performance.

They feature efficiency class **IE3** for three-phase motors and **IE2** for single-phase motors, bolstered by class F insulation and IPX4 protection.

APPLICATION LIMITS

- Manometric suction head up to **7 m**
- Liquid temperature between **-10 °C** and **+90 °C**
- Ambient temperature up to **+40 °C**
- Maximum working pressure:
 - **6 bar** for CP 100-130-132-150-158 ST4
CP 100-130-132-150-158 ST6
 - **8 bar** for CP 170-170M ST4
CP 170-170M ST6
CP 180-190-200 ST4
CP 180-190-200 ST6

AVAILABLE UPON REQUEST

- ※ Mechanical seal options available
- ※ Protection rating IP X5 for CP 170-170M-180-190-200 ST
- ※ Different voltage requirements 60 Hz frequency
- ※ Certified pumps 

CURVES AND PERFORMANCE DATA – HS=0 m

50 Hz

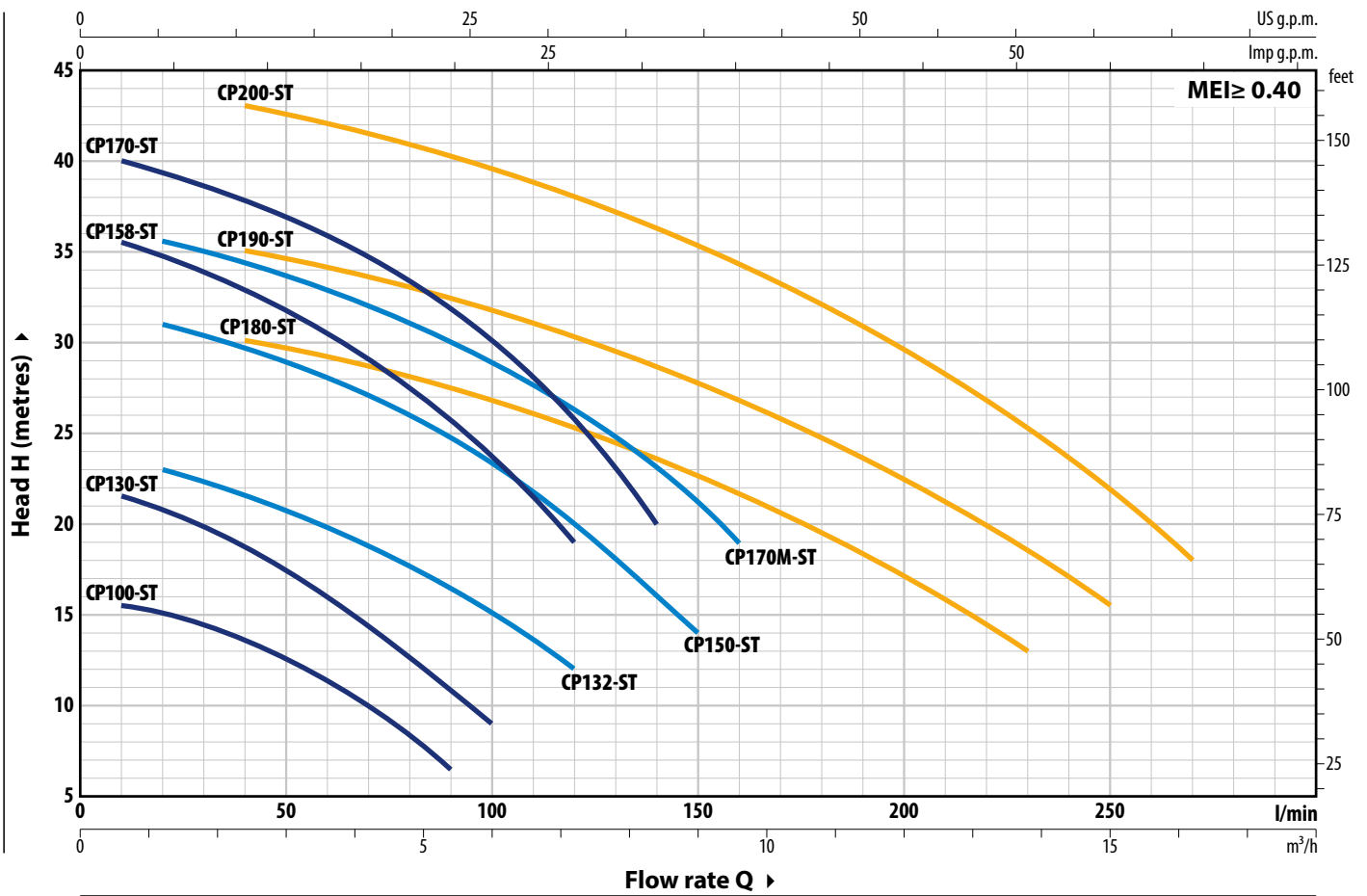

TYPE		POWER (P ₂)		1~3~	Q	H metres																	
Single-phase	Three-phase	kW	HP			m ³ /h	0	0.6	1.2	2.4	3.6	5.4	6.0	7.2	8.4	9.0	9.6	12	13.8	15	16.2		
					l/min	0	10	20	40	60	90	100	120	140	150	160	200	230	250	270			
CPm 100-ST4	CP 100-ST4	0.25	0.33	IE2 IE3	H metres	16	15.5	15	13.5	11.2	6.5												
CPm 100-ST6	CP 100-ST6																						
CPm 130-ST4	CP 130-ST4	0.37	0.50				22.5	21.5	20.8	18.8	16	10.8	9										
CPm 130-ST6	CP 130-ST6																						
CPm 132-ST4	CP 132-ST4	0.55	0.75				24	-	23	21.5	19.8	16.5	15	12									
CPm 132-ST6	CP 132-ST6																						
CPm 150-ST4	CP 150-ST4	0.75	1				32	-	31	29.8	28	24.8	23.2	20	16	14							
CPm 150-ST6	CP 150-ST6																						
CPm 158-ST4	CP 158-ST4	0.75	1				36.5	35.5	34.5	33	31	26.2	24	19									
CPm 158-ST6	CP 158-ST6																						
CPm 170-ST4	CP 170-ST4	1.1	1.5				41	40	39.2	37.8	36	32	30	25.8	20								
CPm 170-ST6	CP 170-ST6																						
CPm 170M-ST4	CP 170M-ST4	1.1	1.5				36.5	-	35.5	34.3	33	30	29	26.4	23	21	19						
CPm 170M-ST6	CP 170M-ST6																						
CPm 180-ST4	CP 180-ST4	1.1	1.5				31.5	-	-	30	29.2	27.5	26.8	25.2	23.5	22.5	21.5	17	13				
CPm 180-ST6	CP 180-ST6																						
CPm 190-ST4	CP 190-ST4	1.5	2		37	-	-	35	34	32.2	31.5	30.2	28.7	27.8	27	22.7	18.5	15.5					
CPm 190-ST6	CP 190-ST6																						
CPm 200-ST4	CP 200-ST4	2.2	3		45	-	-	43	42	40.2	39.5	38	36.5	35.5	34.5	29.8	25.5	22	18				
CPm 200-ST6	CP 200-ST6																						

Q = Flow rate H = Total manometric head HS = Suction height

Performance curves comply with EN ISO 9906 Grade 3B tolerance limits.

CP 100-ST CP130-ST

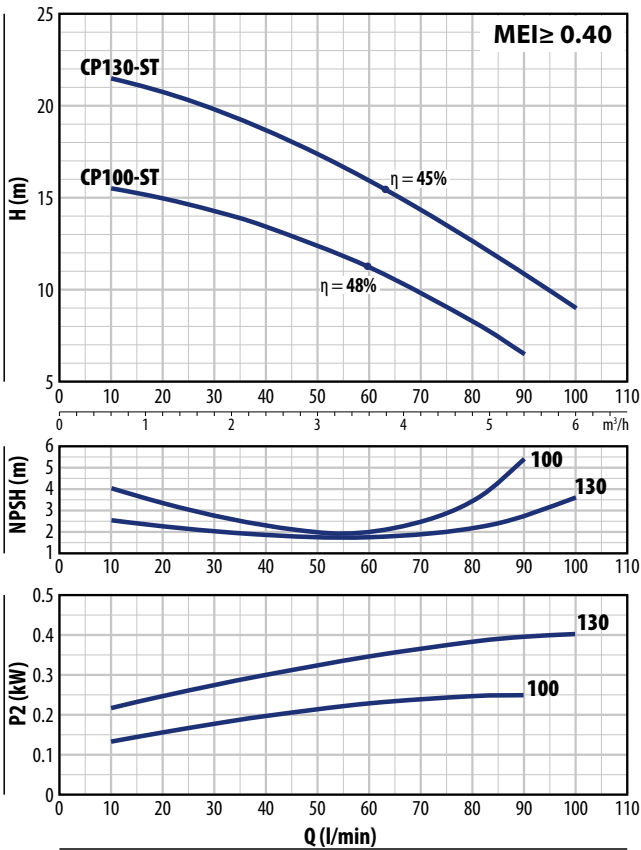

CP 132-ST

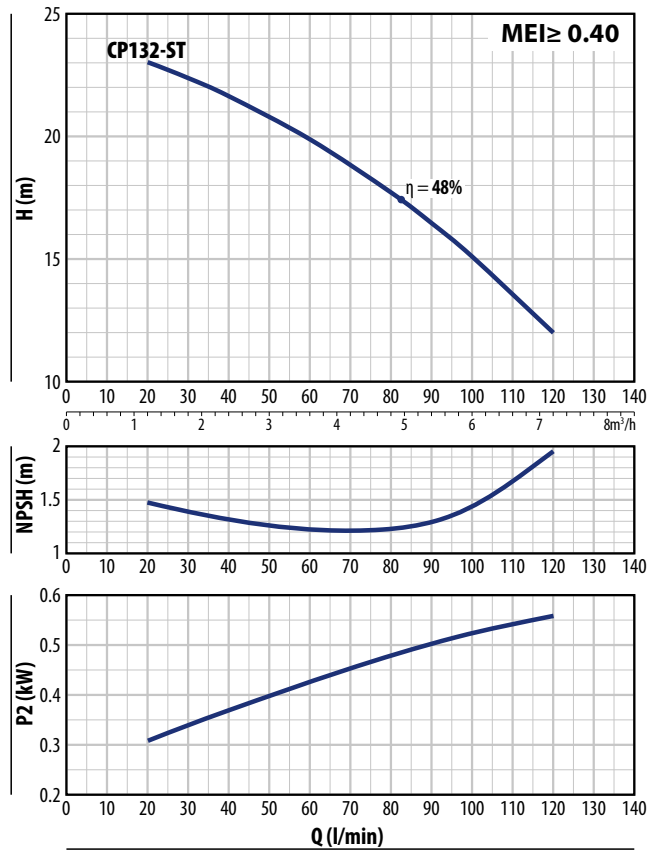

CP 150-ST

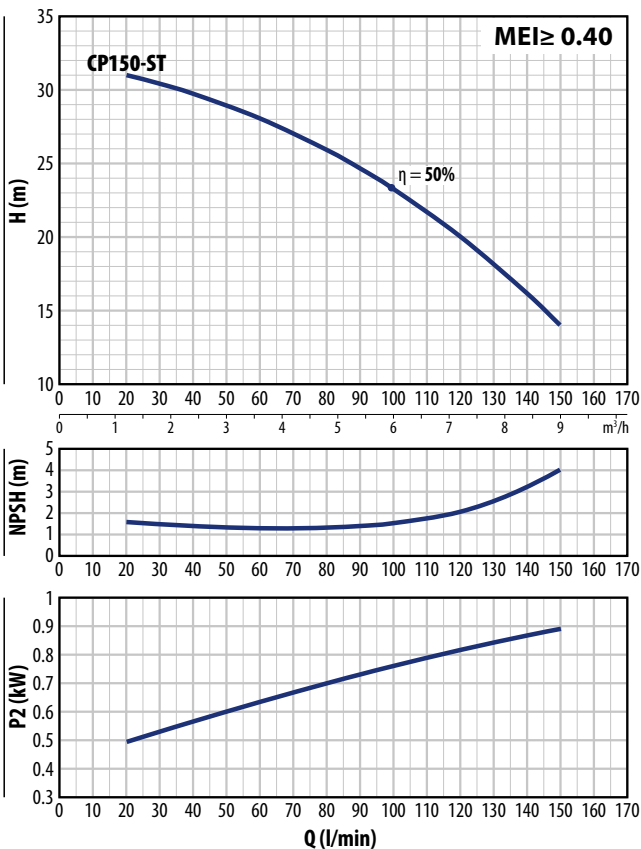

CP 158-ST

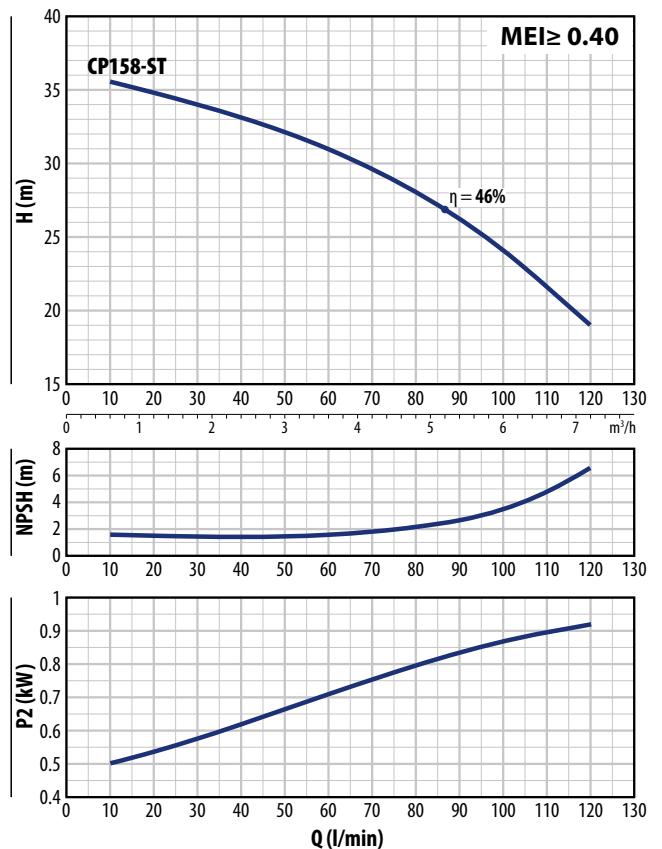

PERFORMANCE CURVES - HS=0 m

50 Hz

CP 170-ST

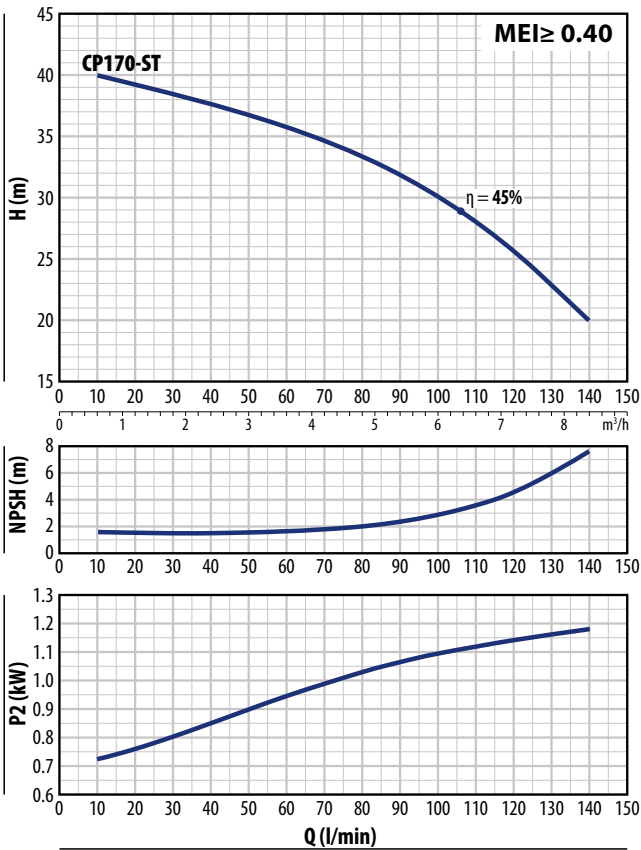

CP 170M-ST

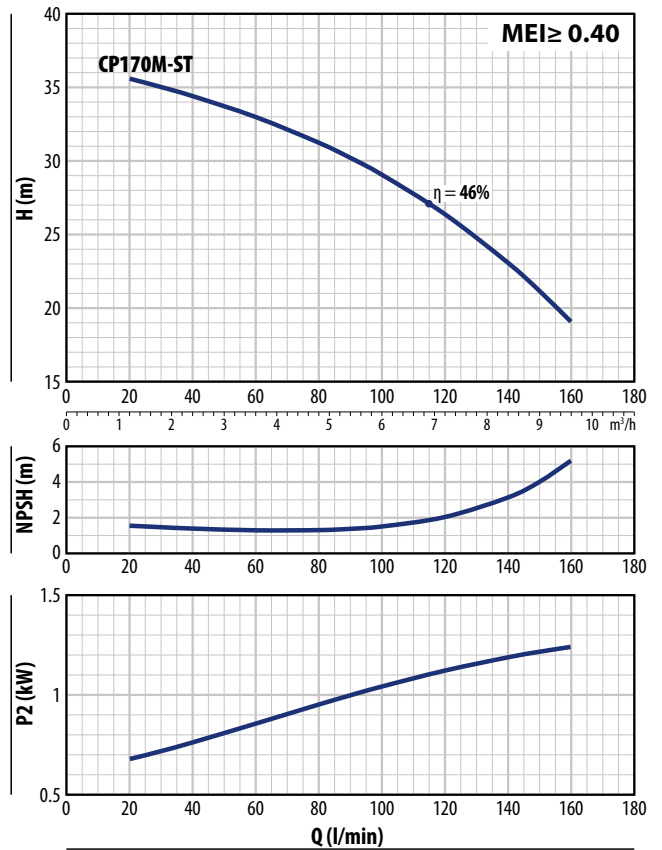

CP 180-ST CP 190-ST CP 200-ST

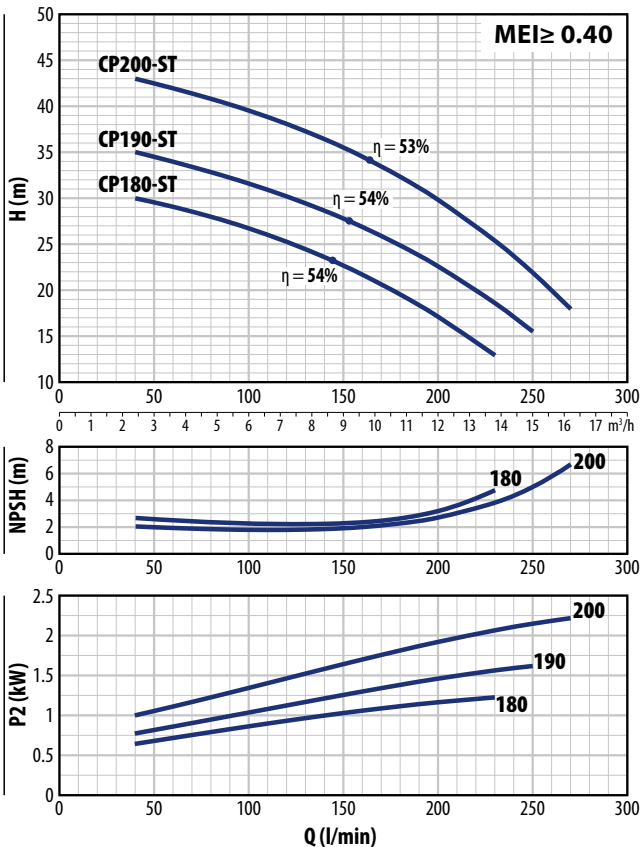

ABSORPTION

TYPE	VOLTAGE
Single-phase	230 V
CPm 100-ST4	2.0 A
CPm 130-ST4	3.0 A
CPm 132-ST4	3.7 A
CPm 150-ST4	6.0 A
CPm 158-ST4	6.0 A
CPm 170-ST4	7.8 A
CPm 170M-ST4	7.8 A
CPm 180-ST4	8.5 A
CPm 190-ST4	10.5 A
CPm 200-ST4	12.8 A

TYPE	VOLTAGE	
	230 V - Δ	400 V - Y
Three-phase		
CP 100-ST4	1.7 A	1.0 A
CP 130-ST4	1.9 A	1.1 A
CP 132-ST4	2.2 A	1.3 A
CP 150-ST4	4.2 A	2.4 A
CP 158-ST4	4.2 A	2.4 A
CP 170-ST4	5.7 A	3.3 A
CP 170M-ST4	5.7 A	3.3 A
CP 180-ST4	5.7 A	3.3 A
CP 190-ST4	6.6 A	3.8 A
CP 200-ST4	8.8 A	5.1 A

DIMENSIONS AND WEIGHT

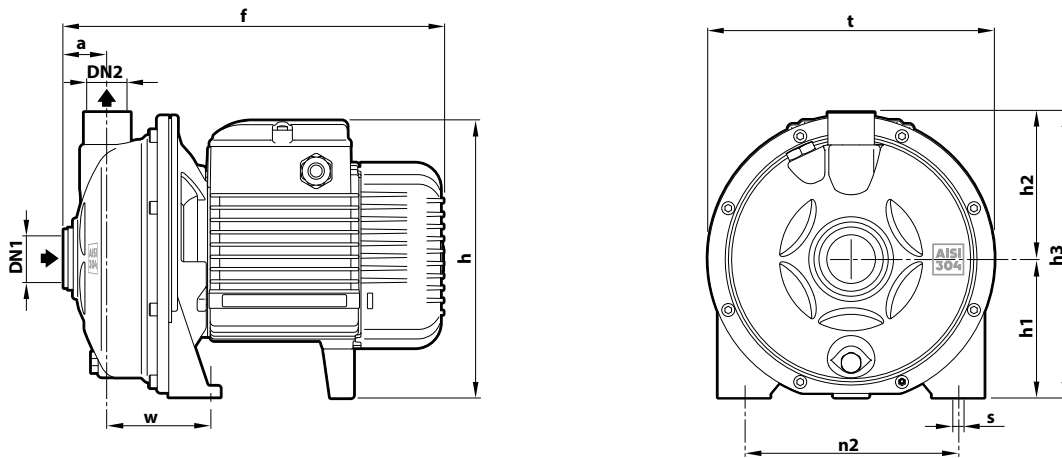

TYPE		PORTS		DIMENSIONS mm										kg	
Single-phase	Three-phase	DN1	DN2	a	f	h	h1	h2	h3	n2	t	w	s	1~	3~
CPm 100-ST4	CP 100-ST4	1 1/4"	1"	31.5	266	181	92	93.5	185.5	120	181	68.5	9	5.8	5.8
CPm 130-ST4	CP 130-ST4													6.7	6.7
CPm 132-ST4	CP 132-ST4													7.4	7.3
CPm 150-ST4	CP 150-ST4			34	296	219 *	107	112	219	165	221	80.5	9.5	11.1	11.1
CPm 158-ST4	CP 158-ST4													11.1	11.1
CPm 170-ST4	CP 170-ST4			33.5	370	251	120	117.5	237.5	180	244	86.5	11	16.0	14.7
CPm 170M-ST4	CP 170M-ST4													15.9	14.6
CPm 180-ST4	CP 180-ST4													15.8	15.8
CPm 190-ST4	CP 190-ST4			33.5	370	250	120	117.5	237.5	180	244	86.5	11	17.1	17.1
CPm 200-ST4	CP 200-ST4													19.6	19.6
					390										

(*) h=233 mm for single-phase 110 V versions

PALLET CAPACITY

TYPE		NO. OF PUMPS
Single-phase	Three-phase	
CPm 100-ST4	CP 100-ST4	96
CPm 130-ST4	CP 130-ST4	96
CPm 132-ST4	CP 132-ST4	96
CPm 150-ST4	CP 150-ST4	50
CPm 158-ST4	CP 158-ST4	50
CPm 170-ST4	CP 170-ST4	45
CPm 170M-ST4	CP 170M-ST4	45
CPm 180-ST4	CP 180-ST4	45
CPm 190-ST4	CP 190-ST4	45
CPm 200-ST4	CP 200-ST4	45

CONSTRUCTION FEATURES

1 Pump body Stainless steel **AISI 304**

2 Cover Stainless steel **AISI 304**

3 Impeller Stainless steel **AISI 304**

4 Mechanical seal	Pump	Seal	Shaft	Materials
	CP 100-130-131-ST4	AR-12	Ø 12 mm	Ceramic / Graphite / NBR / AISI 304
CP 150-158-ST4	AR-14	Ø 14 mm	Ceramic / Graphite / NBR / AISI 304	
CP 170-170M-180-190-200-ST4	FN-18	Ø 18 mm	Graphite / Ceramic / NBR / AISI 316	

5 Motor shaft Stainless steel **AISI 431**

6 Electric motor **CPm-ST4:** single-phase 230 V - 50 Hz with winding integrated thermal motor protection.
CP-ST4: three-phase 230/400 V - 50 Hz
 ※ Pumps are equipped with high-efficiency motors (IEC 60034-30-1)
 class **IE2** for single-phase models
 class **IE3** for three-phase models
 Continuous running duty **S1**

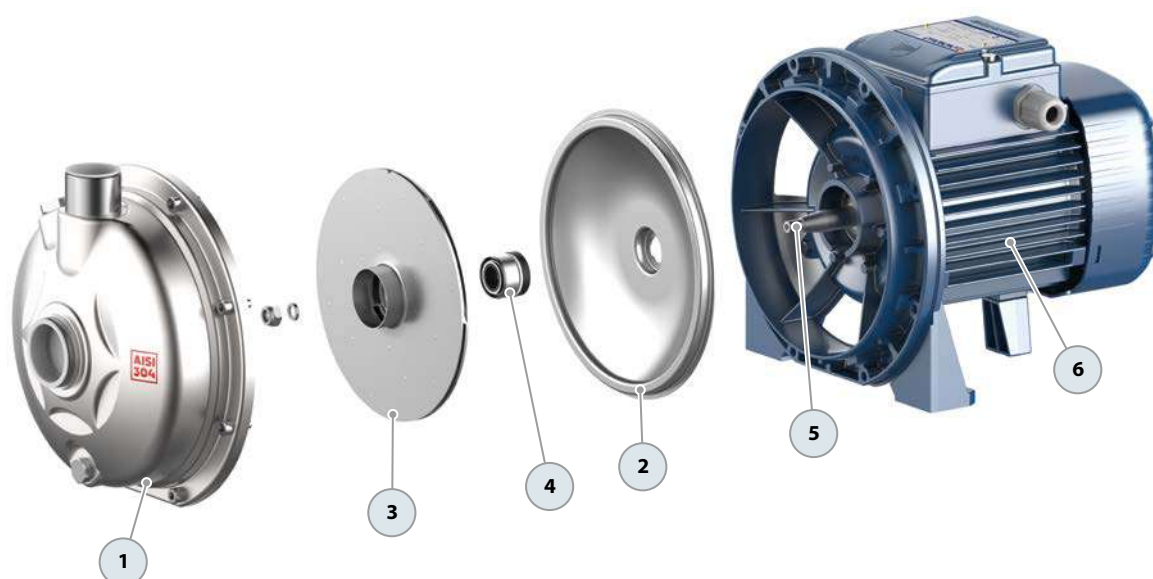

ABSORPTION

TYPE	VOLTAGE
Single-phase	230 V
CPm 100-ST6	2.0 A
CPm 130-ST6	3.0 A
CPm 132-ST6	3.7 A
CPm 150-ST6	6.0 A
CPm 158-ST6	6.0 A
CPm 170-ST6	7.8 A
CPm 170M-ST6	7.8 A
CPm 180-ST6	8.5 A
CPm 190-ST6	10.5 A
CPm 200-ST6	12.8 A

TYPE	VOLTAGE	
Three-phase	230 V - Δ	400 V - 人
CP 100-ST6	1.7 A	1.0 A
CP 130-ST6	1.9 A	1.1 A
CP 132-ST6	2.2 A	1.3 A
CP 150-ST6	4.2 A	2.4 A
CP 158-ST6	4.2 A	2.4 A
CP 170-ST6	5.7 A	3.3 A
CP 170M-ST6	5.7 A	3.3 A
CP 180-ST6	5.7 A	3.3 A
CP 190-ST6	6.6 A	3.8 A
CP 200-ST6	8.8 A	5.1 A

DIMENSIONS AND WEIGHT

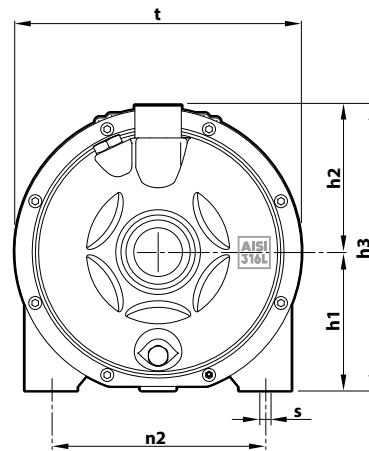
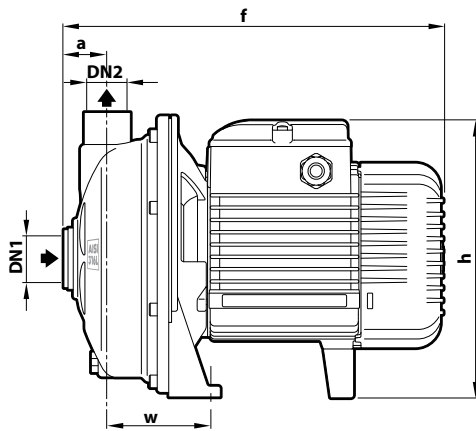

TYPE		PORTS		DIMENSIONS mm										kg	
Single-phase	Three-phase	DN1	DN2	a	f	h	h1	h2	h3	n2	t	w	s	1~	3~
CPm 100-ST6	CP 100-ST6	1 1/4"	1"	31.5	266	181	92	93.5	185.5	120	181	68.5	9	5.8	5.8
CPm 130-ST6	CP 130-ST6													6.7	6.7
CPm 132-ST6	CP 132-ST6													7.4	7.3
CPm 150-ST6	CP 150-ST6			34	296	219 *	107	112	219	165	221	80.5	9.5	11.1	11.1
CPm 158-ST6	CP 158-ST6													11.1	11.1
CPm 170-ST6	CP 170-ST6			33.5	370	251	120	117.5	237.5	180	244	86.5	11	16.0	14.7
CPm 170M-ST6	CP 170M-ST6													15.9	14.6
CPm 180-ST6	CP 180-ST6													15.8	15.8
CPm 190-ST6	CP 190-ST6			33.5	370	250	120	117.5	237.5	180	244	86.5	11	17.1	17.1
CPm 200-ST6	CP 200-ST6													19.6	19.6
					390										

(*) h=233 mm for single-phase 110 V versions

PALLET CAPACITY

TYPE		NO. OF PUMPS
Single-phase	Three-phase	
CPm 100-ST6	CP 100-ST6	96
CPm 130-ST6	CP 130-ST6	96
CPm 132-ST6	CP 132-ST6	96
CPm 150-ST6	CP 150-ST6	50
CPm 158-ST6	CP 158-ST6	50
CPm 170-ST6	CP 170-ST6	45
CPm 170M-ST6	CP 170M-ST6	45
CPm 180-ST6	CP 180-ST6	45
CPm 190-ST6	CP 190-ST6	45
CPm 200-ST6	CP 200-ST6	45

CONSTRUCTION FEATURES

1 Pump body Stainless steel **AISI 316L**

2 Cover Stainless steel **AISI 316L**

3 Impeller Stainless steel **AISI 316L**

4 Mechanical seal	Pump	Seal	Shaft	Materials
	CP 100-130-132-ST6	AR-12ST6	Ø 12 mm	Ceramic / Graphite / NBR / AISI 316
	CP 150-158-ST6	AR-14ST6	Ø 14 mm	Ceramic / Graphite / NBR / AISI 316
	CP 170-170M-180-190-200-ST6	FN-18ST6	Ø 18 mm	Graphite / Ceramic / NBR / AISI 316

5 Motor shaft Stainless steel **AISI 316L**

6 Electric motor **CPm-ST6:** single-phase 230 V - 50 Hz with winding integrated thermal motor protection.
CP-ST6: three-phase 230/400 V - 50 Hz
 ※ Pumps are equipped with high-efficiency motors (IEC 60034-30-1)
 class **IE2** for single-phase models
 class **IE3** for three-phase models
 Continuous running duty **S1**

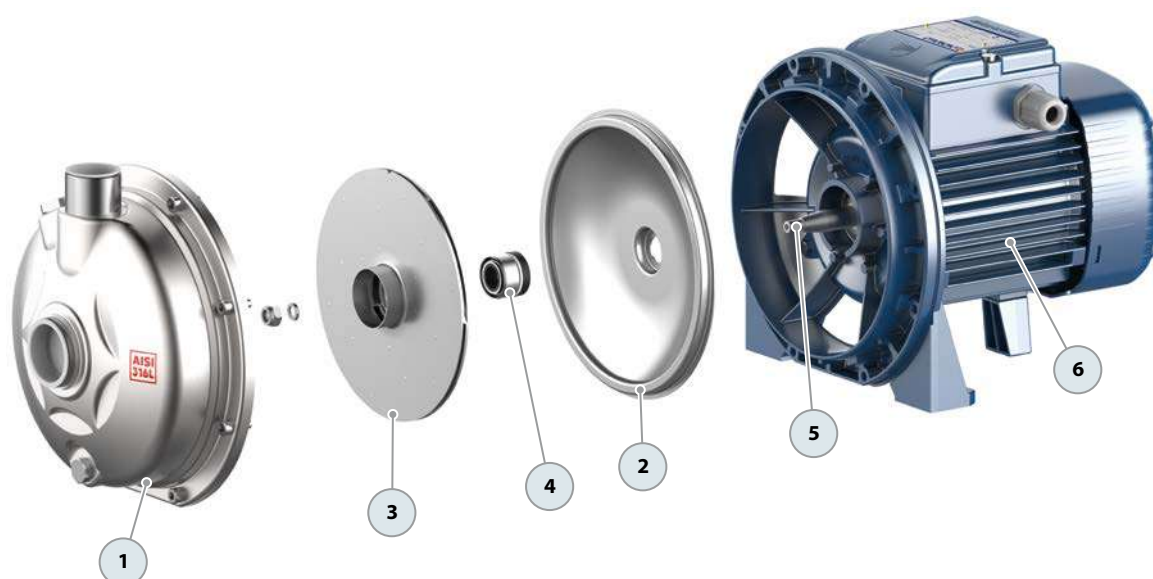

-  Clean water
-  Domestic use
-  Civil use



PERFORMANCE RANGE

- Flow rate up to **160 l/min** (9.6 m³/h)
- Head up to **56 m**

INSTALLATION AND USE

Designed to transfer clean water free from abrasive particles and liquids that will not damage the pump's components.

Reliable and easy to operate, these pumps have extensive application in domestic and civil settings, particularly for distributing water with small to medium-sized pressure tanks, transferring fluids, and watering orchards and gardens.

※ **The AISI 304 stainless steel impeller comes with a ten-year guarantee**

ELECTRIC MOTOR

Equipped with cutting-edge electric motors, the three-phase pumps are designed to work with inverters, offering stable and noiseless performance.

They feature efficiency class **IE3** for three-phase motors and **IE2** for single-phase motors, bolstered by class F insulation and IPX4 protection.

APPLICATION LIMITS

- Manometric suction head up to **7 m**
- Liquid temperature between **-10 °C** and **+90 °C**
- Ambient temperature up to **+40 °C**
- Maximum working pressure:
 - **6 bar** for CP 100-130-132-150-158
 - **10 bar** for CP 170-190-200

AVAILABLE UPON REQUEST

- ✘ Mechanical seal options available
- ✘ Protection rating IP X5 for CP 170, CP 170M
- ✘ Different voltage requirements 60 Hz frequency

PATENTS - TRADE MARKS - MODELS

- CPm158 registered trademark no. 0001516350
- Registered community model no. 002098434

CURVES AND PERFORMANCE DATA – HS=0 m

50 Hz

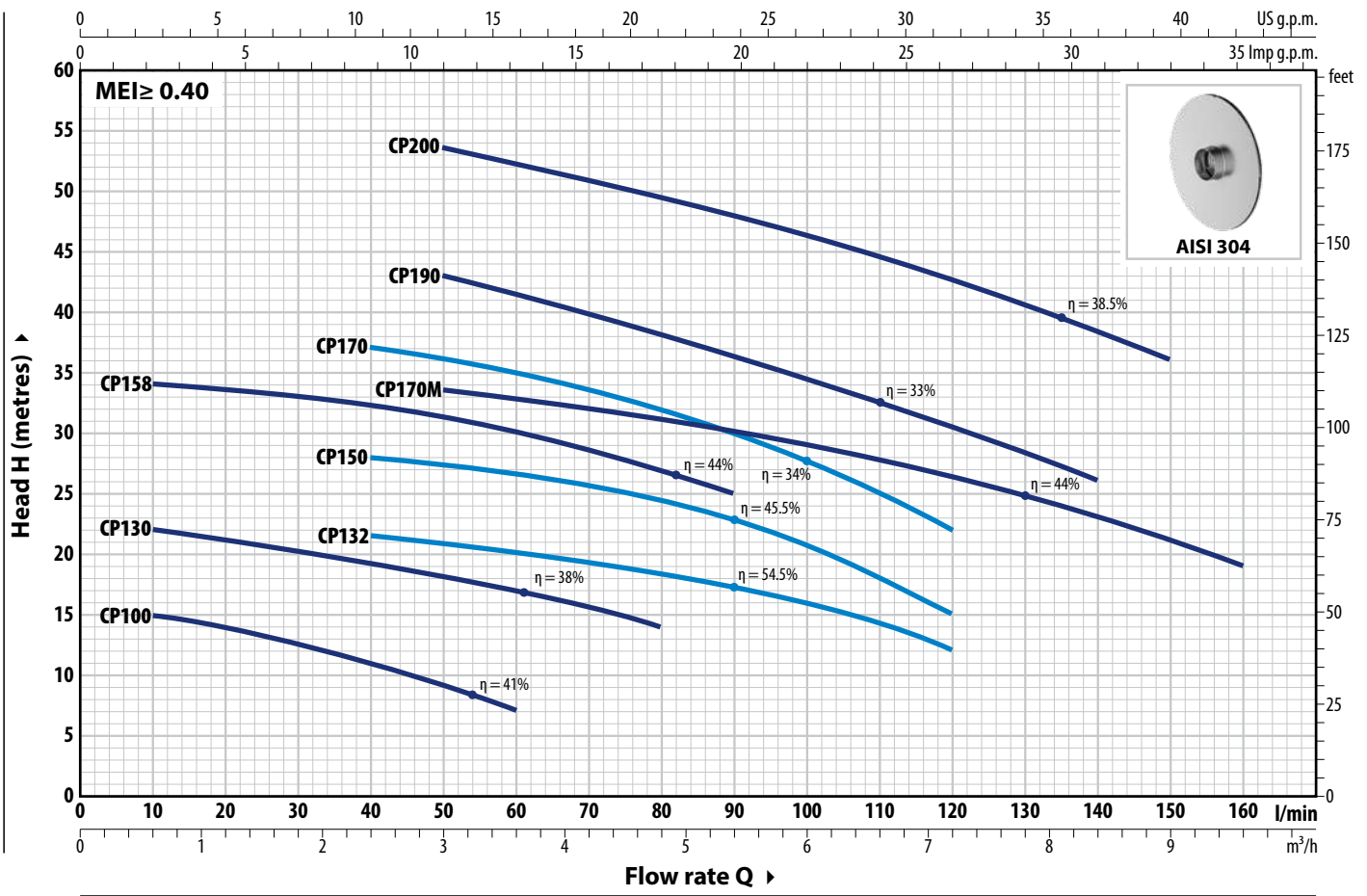

TYPE		POWER (P ₂)		Q	H metres																			
Single-ph.	Three-ph.	kW	HP		1~	3~	0	0.6	1.2	1.8	2.4	3.0	3.6	4.2	4.8	5.4	6.0	6.6	7.2	7.8	8.4	9.0	9.6	
						0	10	20	30	40	50	60	70	80	90	100	110	120	130	140	150	160		
CPm 100	CP 100	0.25	0.33	IE2 IE3	H metres	16	15	14	12.5	11	9	7												
CPm 130	CP 130	0.37	0.50			23	22	21	20	19	18	17	15.5	14										
CPm 132	CP 132	0.55	0.75			23	-	22.5	22	21.5	21	20.5	19.5	18.5	17.5	16	14	12						
CPm 150	CP 150	0.75	1			29.5	-	29	28.5	28	27.5	26.5	26	24.5	23	21	18	15						
CPm 158	CP 158	0.75	1			36	34	33.5	33	32.5	31.5	30	28.5	27	25									
CPm 170	CP 170	1.1	1.5			41	-	-	38	37	36	35	33.5	32	30	27.5	25	22						
CPm 170M	CP 170M	1.1	1.5			36	-	-	35	34.5	33.5	33	32	31	30	29	28	26.5	25	23	21	19		
CPm 190	CP 190	1.5	2			48	-	-	46	44.5	43	41.5	40	38	36	34.5	32.5	30.5	28	26				
CPm 200	CP 200	2.2	3			56	-	-	55	54.5	53.5	52	51	49.5	48	46	44.5	42.5	40.5	38.5	36			

Q = Flow rate H = Total manometric head HS = Suction height

Performance curves comply with EN ISO 9906 Grade 3B tolerance limits.

ABSORPTION

TYPE	VOLTAGE
Single-phase	230 V
CPm 100	1.9 A
CPm 130	3.2 A
CPm 132	3.9 A
CPm 150	5.7 A
CPm 158	6.0 A
CPm 170 - 170M	7.8 A
CPm 190	11.0 A
CPm 200	13.0 A

TYPE	VOLTAGE	
	230 V - Δ	400 V - Y
CP 100	1.6 A	0.95 A
CP 130	2.0 A	1.15 A
CP 132	2.2 A	1.3 A
CP 150	4.2 A	2.4 A
CP 158	4.3 A	2.5 A
CP 170 - 170M	5.2 A	3.0 A
CP 190	7.4 A	4.3 A
CP 200	9.3 A	5.4 A

DIMENSIONS AND WEIGHT

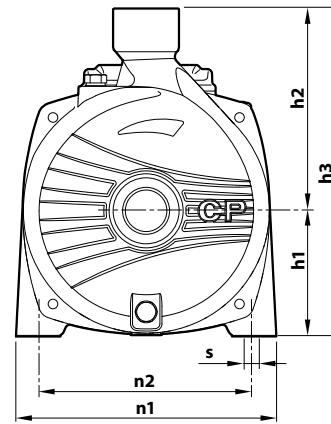
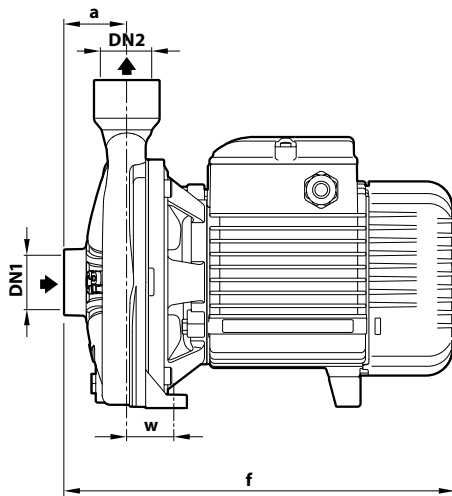

TYPE		PORTS		DIMENSIONS mm									kg	
Single-ph.	Three-ph.	DN1	DN2	a	f	h3	h1	h2	n1	n2	w	s	1~	3~
CPm 100	CP 100	1"	1"	42	257	205	82	123	165	135	38	11	7.0	7.0
CPm 130	CP 130												7.8	7.8
CPm 132	CP 132												8.5	8.5
CPm 150	CP 150												12.3	12.2
CPm 158	CP 158												12.4	12.3
CPm 170	CP 170	1 1/4"	1"	51	367	260	110	150	206	165	44.5	11	19.1	17.6
CPm 170M	CP 170M												19.3	17.9
CPm 190	CP 190												21.6	21.5
CPm 200	CP 200												24.6	24.6
				47.5	364	290	115	175	242	206	36.5			
					384									

PALLET CAPACITY

TYPE		NO. OF PUMPS
Single-ph.	Three-ph.	
CPm 100	CP 100	96
CPm 130	CP 130	96
CPm 132	CP 132	96
CPm 150	CP 150	70
CPm 158	CP 158	70
CPm 170	CP 170	50
CPm 170M	CP 170M	50
CPm 190	CP 190	36
CPm 200	CP 200	36

CONSTRUCTION FEATURES

1 Pump body Cast iron with cathaphoresis treatment with ISO 228/1 threaded ports

2 Cover **AISI 304** stainless steel (cast iron for models CP 170-170M-190-200)

3 Impeller Stainless steel **AISI 304**

4 Mechanical seal	Pump	Seal	Shaft	Materials
	CP 100-130-132	AR-12	Ø 12 mm	Ceramic / Graphite / NBR
	CP 150-158	AR-14	Ø 14 mm	Ceramic / Graphite / NBR
	CP 170-170M-190-200	FN-18	Ø 18 mm	Graphite / Ceramic / NBR

5 Motor shaft Stainless steel **AISI 431**

6 Electric motor **CPm**: single-phase 230 V - 50 Hz with winding integrated thermal motor protection.
CP: three-phase 230/400 V - 50 Hz
 ※ Pumps are equipped with high-efficiency motors (IEC 60034-30-1)
 class **IE2** for single-phase models
 class **IE3** for three-phase models
 Continuous running duty **S1**



 Clean water

 Civil use

 Agricultural use

 Industrial use

PERFORMANCE RANGE

- Flow rate up to **900 l/min** (54 m³/h)
- Head up to **76 m**

INSTALLATION AND USE

Designed to transfer clean water free from abrasive particles and liquids that will not damage the pump's components.

Reliable and easy to operate, these pumps are widely used in civil, agricultural, and industrial settings for water supply, air conditioning and cooling systems, and irrigation purposes.

ELECTRIC MOTOR

Equipped with cutting-edge electric motors, the three-phase pumps are designed to work with inverters, offering stable and noiseless performance.

They feature efficiency class **IE3** for three-phase motors and **IE2** for single-phase motors, bolstered by class F insulation and IPX4 protection for models CP160 and CP210, and IPX5 protection for models CP220, CP230, and CP250.

APPLICATION LIMITS

- Manometric suction head up to **7 m**
- Liquid temperature between **-10 °C** and **+90 °C**
- Ambient temperature between **-10 °C** and **+40 °C**
- Maximum working pressure **10 bar**

AVAILABLE UPON REQUEST

- ✘ Mechanical seal options available
- ✘ Pump shaft in stainless steel AISI 316 - EN 10088-3 - 1.4401 for CP 220, CP 230, CP 250
- ✘ Protection rating IP X5 for CP 160 and CP 210
- ✘ Different voltage requirements 60 Hz frequency

PATENTS - TRADE MARKS - MODELS

- Registered community model No. 002098434 for CP 160, CP 210, CP 250
- Italian registered model no. 72753 for CP 220, CP 230

CURVES AND PERFORMANCE DATA – HS=0 m

50 Hz

CP 160

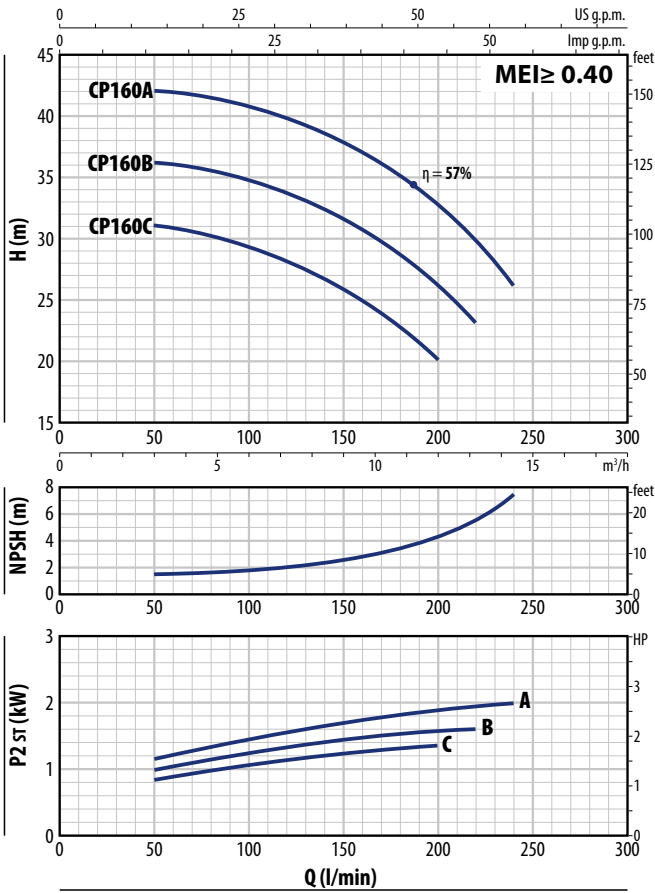

CP 210

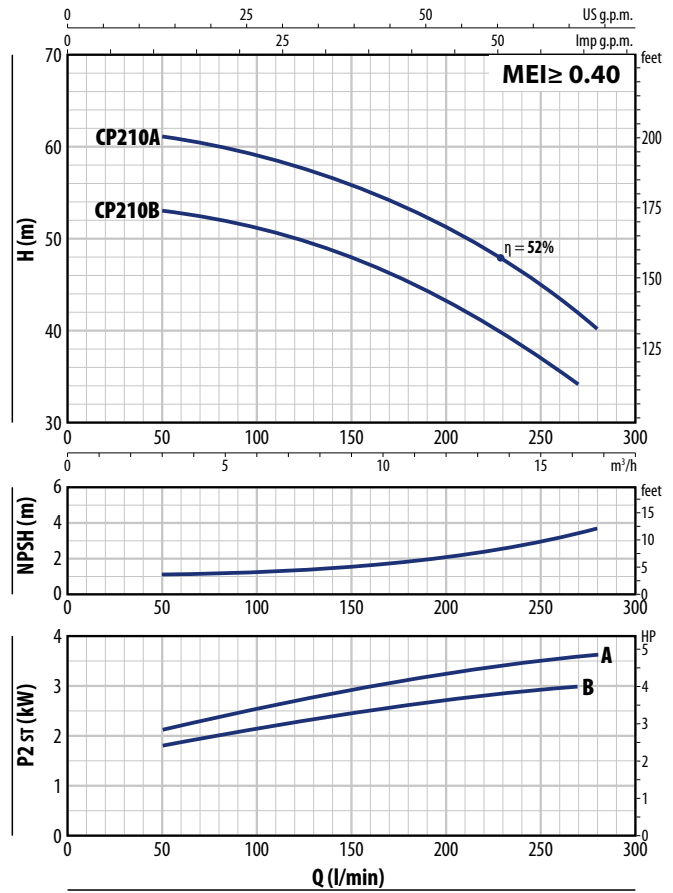

CP 160

TYPE		POWER (P ₂)		1~3~	Q	m ³ /h													
Single-ph.	Three-ph.	kW	HP			0	3	4.5	6	7.5	9	10.5	12	13.2	14.4				
					0	50	75	100	125	150	175	200	220	240					
CPm 160C	CP 160C	1.1	1.5	IE2 IE3	H metres	32	31	30.5	29.5	28	26	23	20						
CPm 160B	CP 160B	1.5	2			37	36	35.5	34.5	33.5	31.5	29	26.5	23					
CPm 160A	CP 160A	2.2	3			43	42	41.5	40.5	39.5	38	35.5	33	30	26				

CP 210

TYPE		POWER (P ₂)		3~	Q	m ³ /h													
Three-ph.		kW	HP			0	3	4.5	6	7.5	9	10.5	12	13.2	14.4	15	16.2	16.8	
					0	50	75	100	125	150	175	200	220	240	250	270	280		
CP 210B		3	4	IE3	H metres	54	53	52	51	49.5	48	45.5	43	40	38.5	37	34		
CP 210A		4	5.5			61	61	60	59	57.5	56	53.5	51	49	46.5	45	42	40	

Q = Flow rate H = Total manometric head HS = Suction height

Performance curves comply with EN ISO 9906 Grade 3B tolerance limits.

CP 220

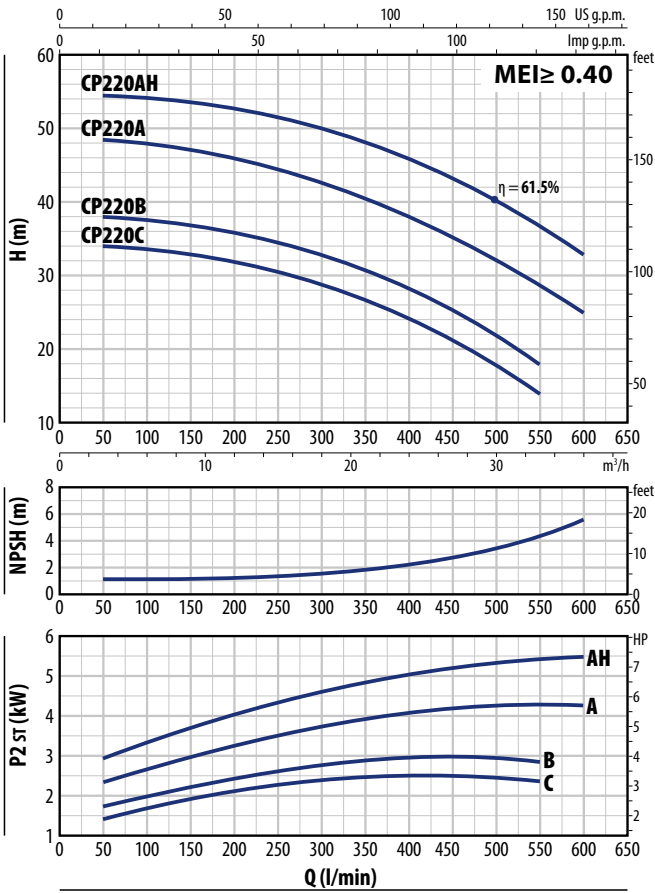

CP 230

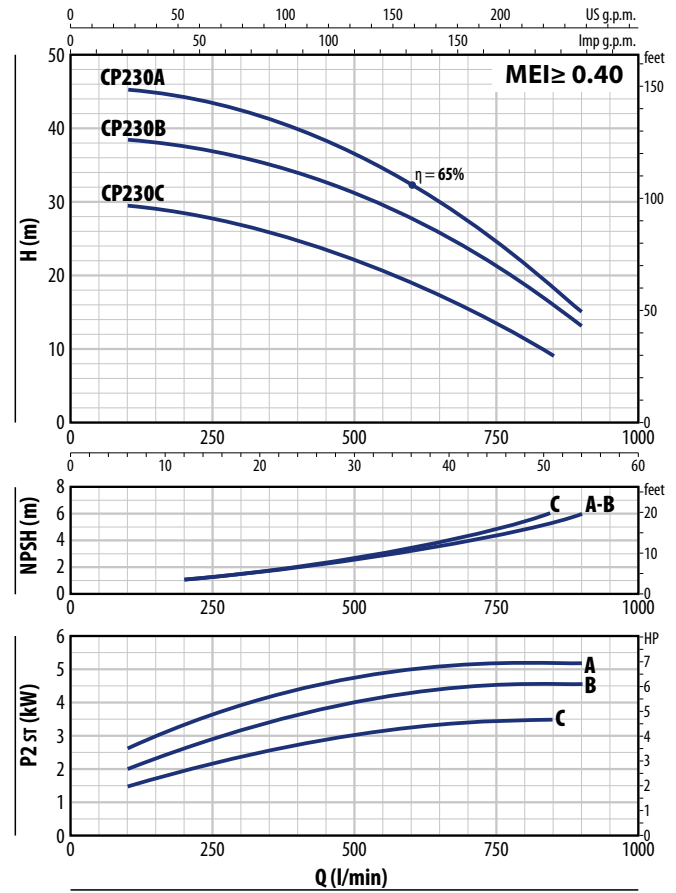

CP 220

TYPE		POWER (P ₂)		1~3~	Q	H metres									
Single-phase	Three-phase	kW	HP			0	3	6	12	18	24	30	33	36	
	CP 220C	2.2	3	IE2 IE3	l/min	0	50	100	200	300	400	500	550	600	
	CP 220B	3	4			34	34	33.5	32	29	24.3	18	14		
	CP 220A	4	5.5			38	38	37.5	36	33	28.5	22	18		
	CP 220AH	5.5	7.5			49	48.5	48	46	42.5	38	32	29	25	
						54.5	54.5	54	52.5	50	46	40.5	37	33	

CP 230

TYPE		POWER (P ₂)		3~	Q	H metres										
Three-phase		kW	HP			0	6	12	18	24	30	36	42	48	51	54
	CP 230C	3	4	IE3	l/min	0	100	200	300	400	500	600	700	800	850	900
	CP 230B	4	5.5			30	29.5	28.5	27	25	22	19.5	15.5	11.5	9	
	CP 230A	5.5	7.5			39	38.5	38	36	34	31	28	24	18.5	15	13
						46	45.5	44.5	42	40	37	32.5	27.5	21.5	18	15

Q = Flow rate H = Total manometric head HS = Suction height

Performance curves comply with EN ISO 9906 Grade 3B tolerance limits.

CURVES AND PERFORMANCE DATA – HS=0 m

50 Hz

CP 250

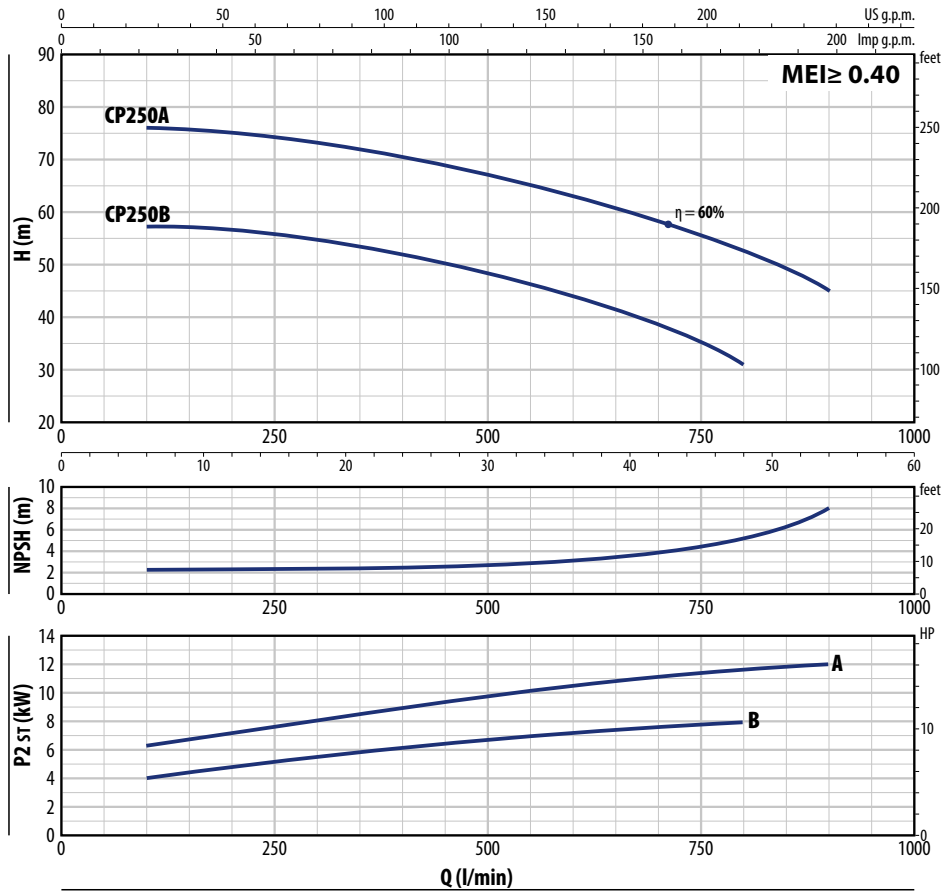

CP 250

TYPE	POWER (P ₂)		3~	Q	Flow rate (Q)												
	kW	HP			m ³ /h	0	6	12	18	24	30	36	42	48	54		
Three-phase				l/min	0	100	200	300	400	500	600	700	800	900			
CP 250B	7.5	10	IE3	H metres	57	57	56.5	54.5	52	48.5	44	38	31				
CP 250A	11	15		76	76	75	73.5	71	67.5	63	58	52	45				

Q = Flow rate H = Total manometric head HS = Suction height

Performance curves comply with EN ISO 9906 Grade 3B tolerance limits.

ABSORPTION

TYPE	VOLTAGE
Single-phase	230 V
CPm 160C	8.5 A
CPm 160B	10.3 A
CPm 160A	13.0 A
CPm 220C	14.2 A

TYPE	VOLTAGE				
	Three-ph.	230 V - Δ	400 V - Δ	400 V - Δ	690 V - Δ
CP 160C	5.7 A	3.3 A	-	-	-
CP 160B	6.9 A	4.0 A	-	-	-
CP 160A	8.8 A	5.1 A	-	-	-
CP 210B	12.6 A	7.3 A	-	-	-
CP 210A	15.1 A	8.7 A	-	-	-
CP 220C	9.0 A	5.2 A	-	-	-
CP 220B	12.6 A	7.3 A	-	-	-
CP 220A	17.0 A	9.8 A	-	-	-
CP 220AH	-	-	11.5 A	6.6 A	-
CP 230C	13.1 A	7.6 A	-	-	-
CP 230B	16.8 A	9.7 A	-	-	-
CP 230A	-	-	11.5 A	6.6 A	-
CP 250B	-	-	15.0 A	8.7 A	-
CP 250A	-	-	22.5 A	13.0 A	-

DIMENSIONS AND WEIGHT

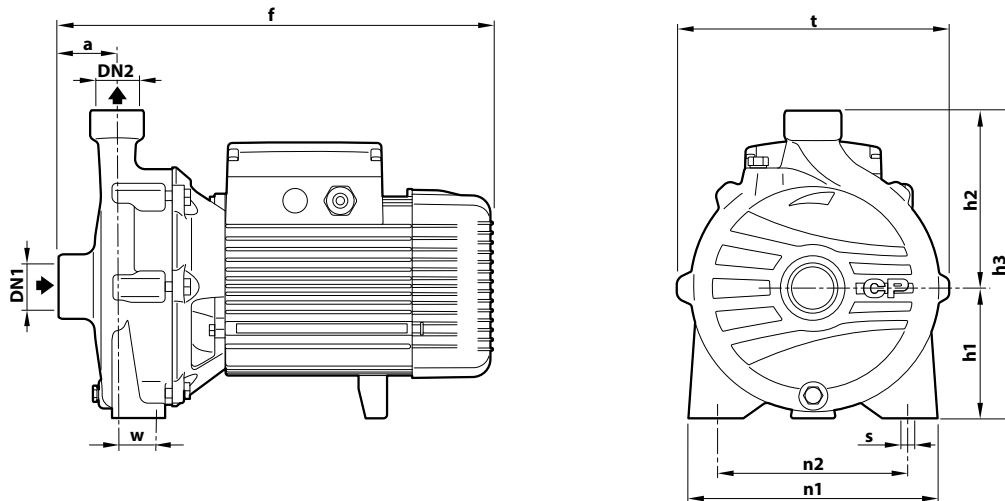

TYPE		PORTS		DIMENSIONS mm										kg								
Single-ph.	Three-ph.	DN1	DN2	a	f	h1	h2	h3	t	n1	n2	w	s	1~	3~							
CPm 160C	CP 160C	1½"	1"	54	370	110	150	260	-	206	165	44.5	11	18.7	18.8							
CPm 160B	CP 160B				390									20.0	20.0							
CPm 160A	CP 160A			60	454	132	180	312						274	205	35	-	33.8				
-	CP 210B			-	-	-	-	-						-	-	-	-	37.2				
-	CP 210A			-	-	-	-	-						-	-	-	-	-				
CPm 220C	CP 220C	2"	2"	70	428	132	183	315	243	230	170	40	14	29.5	32.3							
-	CP 220B				-									-	-	-	-	-	-	-	-	34.2
-	CP 220A				-									-	-	-	-	-	-	-	-	41.0
-	CP 220AH			70	468	136	192	328	273	250	190	40		-	47.0							
-	CP 230C			-	-	-	-	-	-	-	-	-		-	37.2							
-	CP 230B			-	-	-	-	-	-	-	-	-		-	41.0							
-	CP 230A			-	-	-	-	-	-	-	-	-		-	46.0							
-	CP 250B			65	519	160	232	392	317	294	230	45		-	67.0							
-	CP 250A			-	570	-	-	-	-	-	-	-		-	98.0							

PALLET CAPACITY

TYPE		NO. OF PUMPS
Single-ph.	Three-ph.	
CPm 160C	CP 160C	50
CPm 160B	CP 160B	50
CPm 160A	CP 160A	35
-	CP 210B	18
-	CP 210A	18

TYPE		NO. OF PUMPS
Single-ph.	Three-ph.	
CPm 220C	CP 220C	18
-	CP 220B	18
-	CP 220A	18
-	CP 220AH	18
-	CP 230C	18
-	CP 230B	18
-	CP 230A	18
-	CP 250B	6
-	CP 250A	6

CONSTRUCTION FEATURES

1 Pump body Cast iron with ISO 228/1 threaded ports

2 Cover Cast iron

3 Impeller Stainless steel for CP160
Brass for CP 210, CP 220, CP 230
Cast iron for CP 250

4 Mechanical seal	Pump	Seal	Shaft	Materials
	CP 160C-B-A	FN-18	Ø 18 mm	Graphite / Ceramic / NBR
	CP 220C	FN-20	Ø 20 mm	Graphite / Ceramic / NBR
	CP 210B-A			
	CP 220B-A-AH	FN-24	Ø 24 mm	Graphite / Ceramic / NBR
	CP 230C-B-A			
	CP 250B			
	CP 250A	FN-32 NU	Ø 32 mm	Graphite / Ceramic / NBR

5 Motor shaft Stainless steel **AISI 431**

6 Electric motor **CPm**: single-phase 230 V - 50 Hz.
CP: three-phase 230/400 V - 50 Hz up to 4 kW.
400/690 V - 50 Hz from 5.5 to 11 kW.
※ Pumps are equipped with high-efficiency motors (IEC 60034-30-1)
class **IE2** for single-phase models
class **IE3** for three-phase models
Continuous running duty **S1**

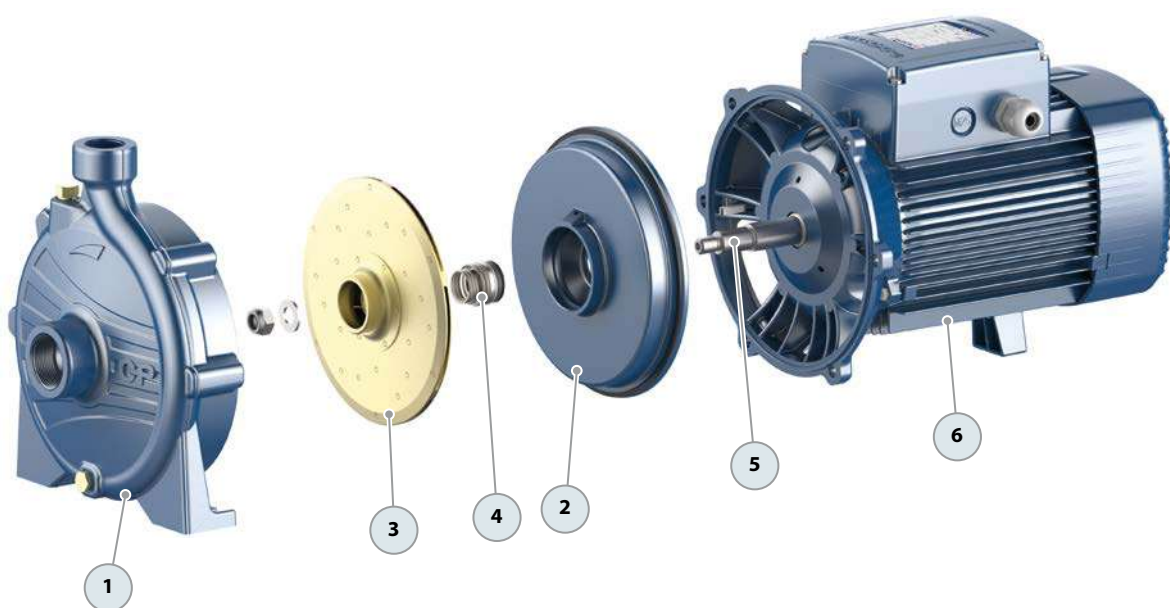

2CP 25/130

Twin impeller centrifugal pump

 Clean water

 Domestic use



INSTALLATION AND USE

Designed to transfer clean water free from abrasive particles and liquids that will not damage the pump's components. They can be used in a variety of applications thanks to their high performance and adaptability.

They are an ideal choice for domestic water distribution when used with pressure tanks.

APPLICATION LIMITS

- Manometric suction head up to **7 m**
- Liquid temperature between **-10 °C** and **+90 °C**
- Ambient temperature up to **+40 °C**
- Maximum working pressure **6 bar**

AVAILABLE UPON REQUEST

- ✘ Mechanical seal options available
- ✘ Different voltage requirements 60 Hz frequency

CURVES AND PERFORMANCE DATA – HS=0 m 50 Hz

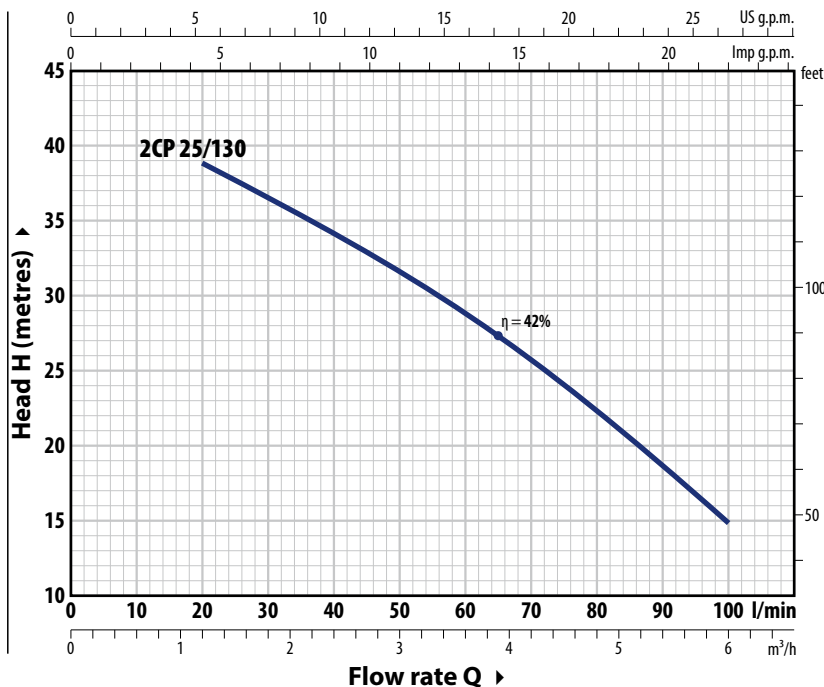

CONSUMPTIONS

TYPE	VOLTAGE
Single-phase	230 V
2CPm 25/130	6.3 A

TYPE	VOLTAGE	
Three-phase	230 V - Δ	400 V - ƿ
2CP 25/130	4.5 A	2.6 A

TYPE		POWER (P ₂)		1~3~	Q	Flow rate										
Single-phase	Three-phase	kW	HP			m ³ /h	0	1.2	1.8	2.4	3	3.6	4.2	4.8	5.4	6
2CPm 25/130	2CP 25/130	0.75	1	IE2 IE3	H metres	42	39	37	34.5	31.5	28.5	25.5	22	18	15	

Q = Flow rate H = Total manometric head HS = Suction height

Performance curves comply with EN ISO 9906 Grade 3B tolerance limits.

DIMENSIONS AND WEIGHT

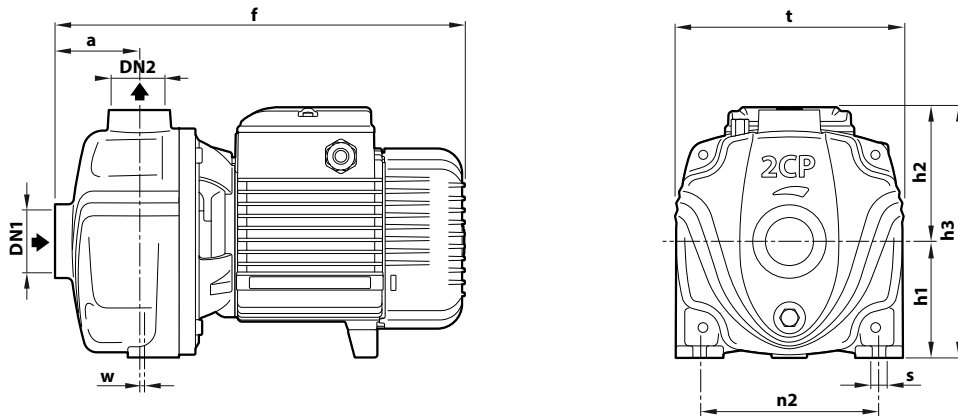

TYPE		PORTS		DIMENSIONS mm									kg	
Single-phase	Three-phase	DN1	DN2	a	f	h1	h2	h3	t	n2	w	s	1~	3~
2CPm 25/130	2CP 25/130	1 1/4"	1"	73	332	92	108	200	180	142	2.5	10	15.5	15.4

MATERIALS AND COMPONENTS

1 Pump body	Cast iron with ISO 228/1 threaded ports (Start of production with new design 06.2024)		
2 Cover	Stainless steel AISI 304		
3 Impellers	Stainless steel AISI 304		
4 Diffusers	Stainless steel AISI 304		
5 Mechanical seal	Seal	Shaft	Materials
	AR-14	Ø 14 mm	Ceramic / Graphite / NBR
6 Motor shaft	Stainless steel AISI 431		
7 Electric motor	2CPm 25/130: single-phase 230 V - 50Hz with winding integrated thermal motor protection 2CP 25/130: three-phase 230/400 V - 50 Hz ※ Pumps are equipped with high-efficiency motors (IEC 60034-30-1) class IE2 for single-phase models class IE3 for three-phase models Continuous running duty S1		

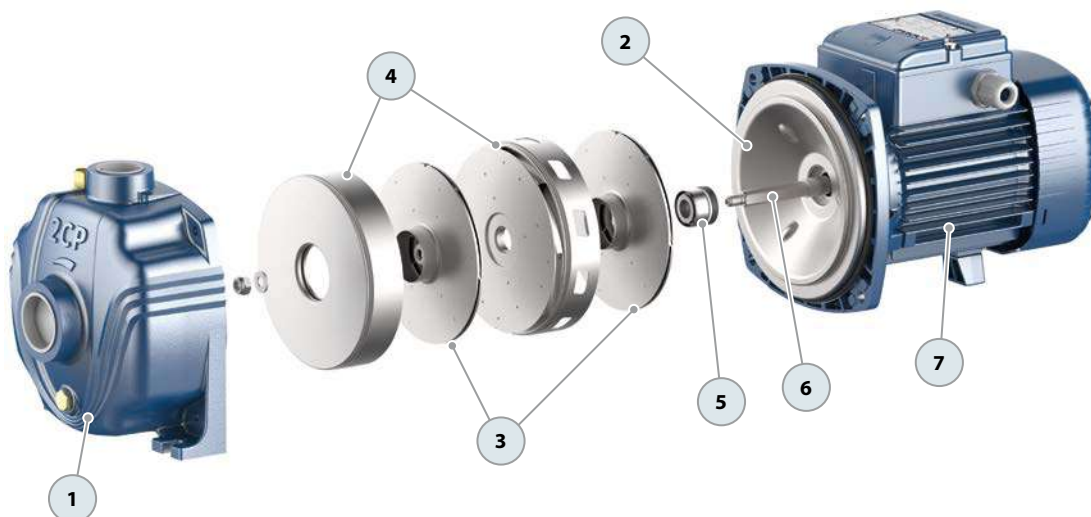

-  Clean water
-  Domestic use
-  Civil use
-  Industrial use



PERFORMANCE RANGE

- Flow rate up to **450 l/min** (27 m³/h)
- Head up to **112 m**

INSTALLATION AND USE

They are recommended for pumping clean water and liquids that are chemically non-aggressive for the pump materials.

Its high efficiency and adaptability to a wide variety of applications make it an ideal choice in the domestic, civil and industrial sectors, particularly for water distribution in conjunction with autoclave tanks, for increasing network pressure, and for fire-fighting units.

ELECTRIC MOTOR

The three-phase pumps are equipped with newly developed electric motors designed to work with inverters, which guarantee stable and quiet operation.

Efficiency class **IE3** for three-phase motors and **IE2** for single-phase motors, with class F insulation and IPX4 protection.

APPLICATION LIMITS

- Manometric suction head up to **7 m**
- Liquid temperature between from **-10 °C** and **+90 °C**
- Ambient temperature between **-10 °C** and **+40 °C**
- Maximum working pressure **10 bar**

AVAILABLE UPON REQUEST

- ✘ Mechanical seal options available
- ✘ Different voltage requirements 60 Hz frequency
- ✘ IPX5 protection for:
 - 2CP32/200 – 2CP40/180
 - 2CP32/210 – 2CP40/200

CURVES AND PERFORMANCE DATA – HS=0 m

50 Hz

2CP 25/14

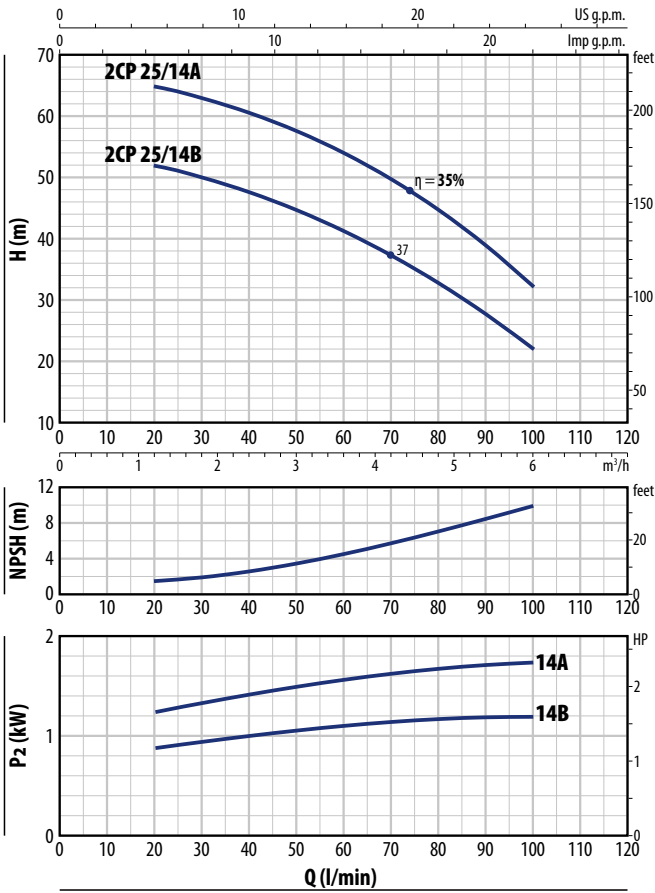

2CP 25/16

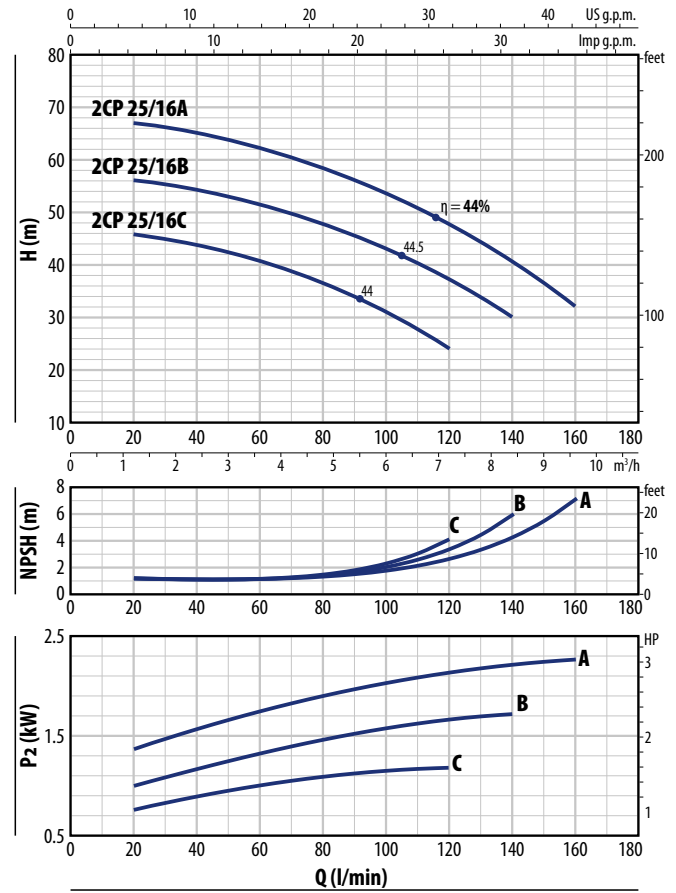

2CP 25/14

TYPE		POWER (P ₂)		1~3~	Q	m ³ /h									
Single-phase	Three-phase	kW	HP			0	1.2	1.8	2.4	3	3.6	4.2	4.8	5.4	6
						0	20	30	40	50	60	70	80	90	100
2CPm 25/14B	2CP 25/14B	1.1	1.5	IE2 IE3	H metres	54	52	50	47.5	44.5	41	37	32.5	27.5	22
2CPm 25/14A	2CP 25/14A	1.5	2			67	65	63	60.5	57.5	54	49.5	44.5	39	32

2CP 25/16

TYPE		POWER (P ₂)		1~3~	Q	m ³ /h								
Single-phase	Three-phase	kW	HP			0	1.2	2.4	3.6	4.8	6	7.2	8.4	9.6
						0	20	40	60	80	100	120	140	160
2CPm 25/16C	2CP 25/16C	1.1	1.5	IE2 IE3	H metres	47	46	44	40.5	36	30.5	24		
2CPm 25/16B	2CP 25/16B	1.5	2			58	56	54	51	47.5	43	37	30	
2CPm 25/16A	2CP 25/16A	2.2	3			68	67	65	62	58.5	54	48	40.5	32

Q = Flow rate H = Total manometric head HS = Suction height

Performance curves comply with EN ISO 9906 Grade 3B tolerance limits.

2CP 32/200

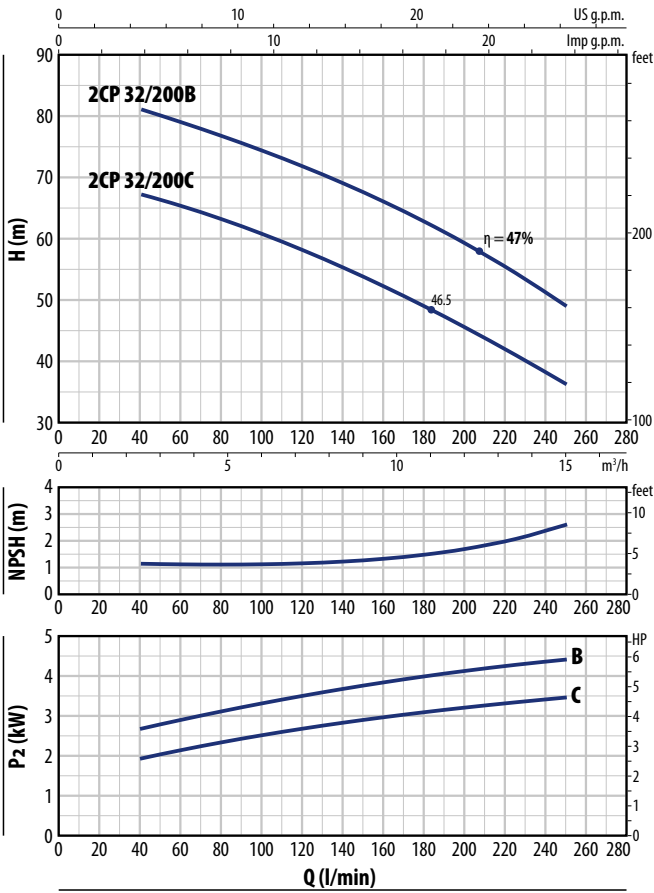

2CP 32/210

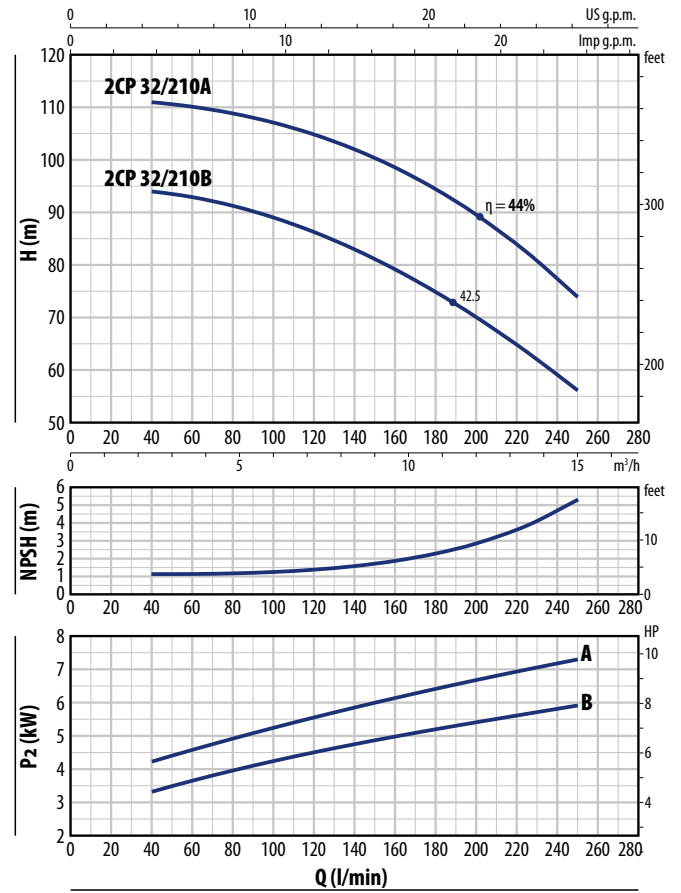

2CP 32/200

TYPE	POWER (P ₂)		3~	Q	Q														
	kW	HP			m ³ /h	0	2.4	3.6	4.8	6	7.2	8.4	9.6	10.8	12	13.5	15		
Three-phase					0	40	60	80	100	120	140	160	180	200	225	250			
2CP 32/200C	3	4	IE3	H metres	70	67	65	63	60.5	58	55	52	48.5	45.5	41	36			
2CP 32/200B	4	5.5			85	81	79	77	74.5	71.5	69	66	62.5	59	54.5	49			

2CP 32/210

TYPE	POWER (P ₂)		3~	Q	Q														
	kW	HP			m ³ /h	0	2.4	3.6	4.8	6	7.2	8.4	9.6	10.8	12	13.5	15		
Three-phase					0	40	60	80	100	120	140	160	180	200	225	250			
2CP 32/210B	5.5	7.5	IE3	H metres	94	94	93	91	89	86	83	79	75	70	63.5	56			
2CP 32/210A	7.5	10			112	111	110	109	107	105	102	99	95	90	82.5	74			

Q = Flow rate H = Total manometric head HS = Suction height

Performance curves comply with EN ISO 9906 Grade 3B tolerance limits.

CURVES AND PERFORMANCE DATA – HS=0 m

50 Hz

2CP 40/180

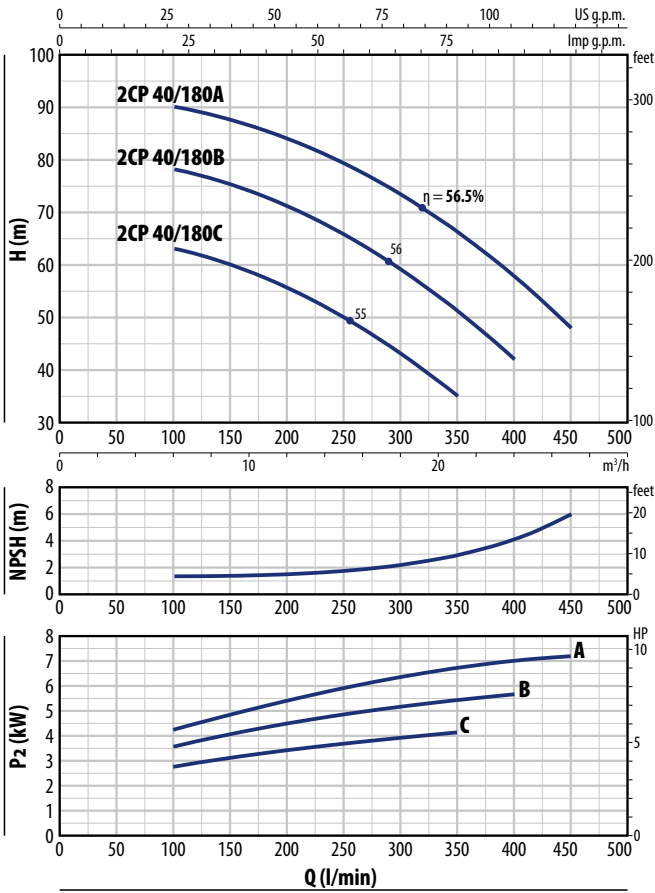

2CP 40/200

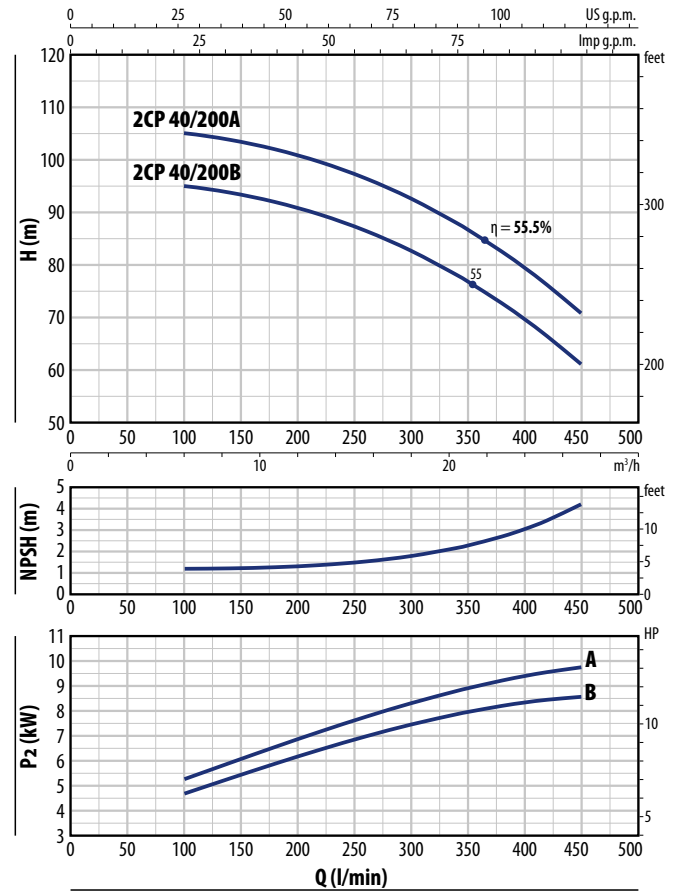

2CP 40/180

TYPE	POWER (P ₂)		3~	Q	Q													
	kW	HP			m ³ /h	0	6	9	12	15	18	21	24	27				
Three-phase				l/min	0	100	150	200	250	300	350	400	450					
2CP 40/180C	4	5.5	IE3	H metres	65	63	60	55.5	50	43	35							
2CP 40/180B	5.5	7.5			80	78	75	71	65.5	59	51	42						
2CP 40/180A	7.5	10			92	90	87.5	84	79	73.5	66	58	48					

2CP 40/200

TYPE	POWER (P ₂)		3~	Q	Q												
	kW	HP			m ³ /h	0	6	9	12	15	18	21	24	27			
Three-phase				l/min	0	100	150	200	250	300	350	400	450				
2CP 40/200B	9.2	12.5	IE3	H metres	96	95	93	91	87	83	77	69.5	61				
2CP 40/200A	11	15			106	105	103	101	97	93	87	79.5	71				

Q = Flow rate H = Total manometric head HS = Suction height

Performance curves comply with EN ISO 9906 Grade 3B tolerance limits.

ABSORPTION

TYPE	VOLTAGE
Single-phase	230 V
2CPm 25/14B	7.7 A
2CPm 25/14A	10.5 A
2CPm 25/16C	7.7 A
2CPm 25/16B	10.0 A
2CPm 25/16A	13.8 A

TYPE	VOLTAGE			
	230 V - Δ	400 V - Δ	400 V - Δ	690 V - Δ
Three-phase				
2CP 25/14B	5.4 A	3.1 A	-	-
2CP 25/14A	6.9 A	4.0 A	-	-
2CP 25/16C	5.4 A	3.1 A	-	-
2CP 25/16B	6.9 A	4.0 A	-	-
2CP 25/16A	9.2 A	5.3 A	-	-
2CP 32/200C	12.8 A	7.4 A	-	-
2CP 32/200B	18.2 A	10.5 A	-	-
2CP 32/210B	-	-	12.5 A	7.2 A
2CP 32/210A	-	-	16.0 A	9.2 A
2CP 40/180C	17.0 A	9.8 A	-	-
2CP 40/180B	-	-	12.3 A	7.1 A
2CP 40/180A	-	-	15.4 A	8.9 A
2CP 40/200B	-	-	17.5 A	10.1 A
2CP 40/200A	-	-	20.0 A	11.6 A

DIMENSIONS AND WEIGHT

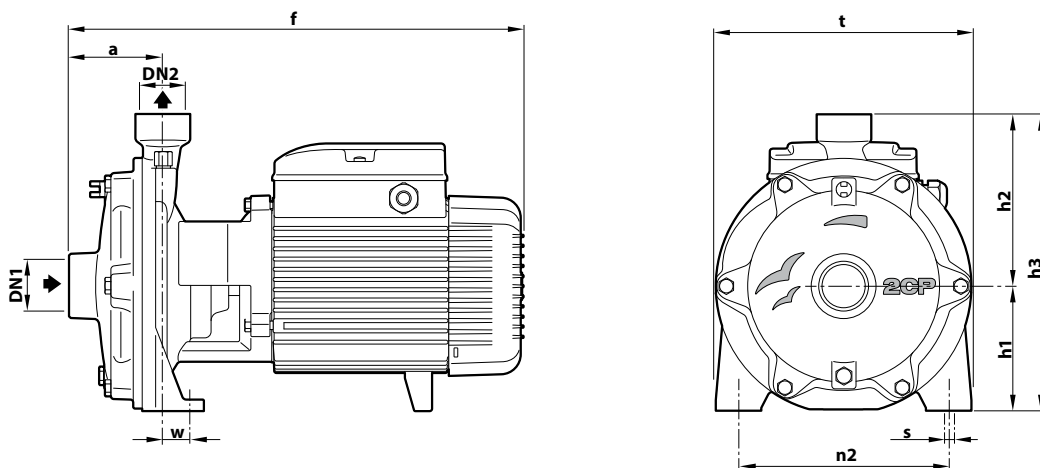

TYPE		PORTS		DIMENSIONS mm									kg	
Single-phase	Three-phase	DN1	DN2	a	f	h1	h2	h3	t	n2	w	s	1~	3~
2CPm 25/14B	2CP 25/14B	1 1/4"	1"	82	404	93	130	223	200	162	17	10	20.8	20.8
2CPm 25/14A	2CP 25/14A					110	151	261	225	185	26	11	24.7	24.6
2CPm 25/16C	2CP 25/16C					93	130	223	200	162	17	10	21.3	20.6
2CPm 25/16B	2CP 25/16B					110	151	261	226	185	26	11	24.5	24.4
2CPm 25/16A	2CP 25/16A			424									27.1	27.3
-	2CP 32/200C	1 1/2"	1 1/4"	95	464	132	172	304	266	206	19		-	38.9
-	2CP 32/200B												-	42.0
-	2CP 32/210B												-	54.9
-	2CP 32/210A												-	60.0
-	2CP 40/180C	2"	1 1/2"	108		139	195	334	292	232	21	14	-	48.7
-	2CP 40/180B												-	53.0
-	2CP 40/180A												-	59.0
-	2CP 40/200B												-	93.0
-	2CP 40/200A			110	620	160	195	355	298				-	92.0

PALLET CAPACITY

TYPE		NO. OF PUMPS
Single-phase	Three-phase	
2CPm 25/14B	2CP 25/14B	50
2CPm 25/14A	2CP 25/14A	50
2CPm 25/16C	2CP 25/16C	50
2CPm 25/16B	2CP 25/16B	50
2CPm 25/16A	2CP 25/16A	35

TYPE	NO. OF PUMPS
Three-phase	
2CP 32/200C	18
2CP 32/200B	18
2CP 32/210B	12
2CP 32/210A	12
2CP 40/180C	12
2CP 40/180B	12
2CP 40/180A	12
2CP 40/200B	6
2CP 40/200A	6

MATERIALS AND COMPONENTS

1	Suction body	Cast iron with ISO 228/1 threaded suction port			
2	Delivery port	Cast iron with ISO 228/1 threaded delivery port			
3	Impellers	Brass			
4	Mechanical seal	Water pump	Seal	Shaft	Materials
		2CP 25/14	FN-18	Ø 18 mm	Graphite / Ceramic / NBR
		2CP 25/16	FN-18	Ø 18 mm	Graphite / Ceramic / NBR
		2CP 32/200	FN-20	Ø 20 mm	Graphite / Ceramic / NBR
		2CP 32/210	FN-24	Ø 24 mm	Graphite / Ceramic / NBR
		2CP 40/180	FN-24	Ø 24 mm	Graphite / Ceramic / NBR
		2CP 40/200	FN-32 NU	Ø 32 mm	Graphite / Ceramic / NBR
5	Motor shaft	Stainless steel AISI 431			
6	Electric motor	<p>2CPm: single-phase 230 V - 50Hz with winding integrated thermal motor protection</p> <p>2CP: three-phase 230/400 V - 50 Hz up to 4 kW 400/690 V - 50 Hz 5.5 to 11 kW</p> <p>※ Pumps are equipped with high-efficiency motors (IEC 60034-30-1)</p> <p>class IE2 for single-phase models</p> <p>class IE3 for three-phase models</p> <p>Continuous running duty S1</p>			

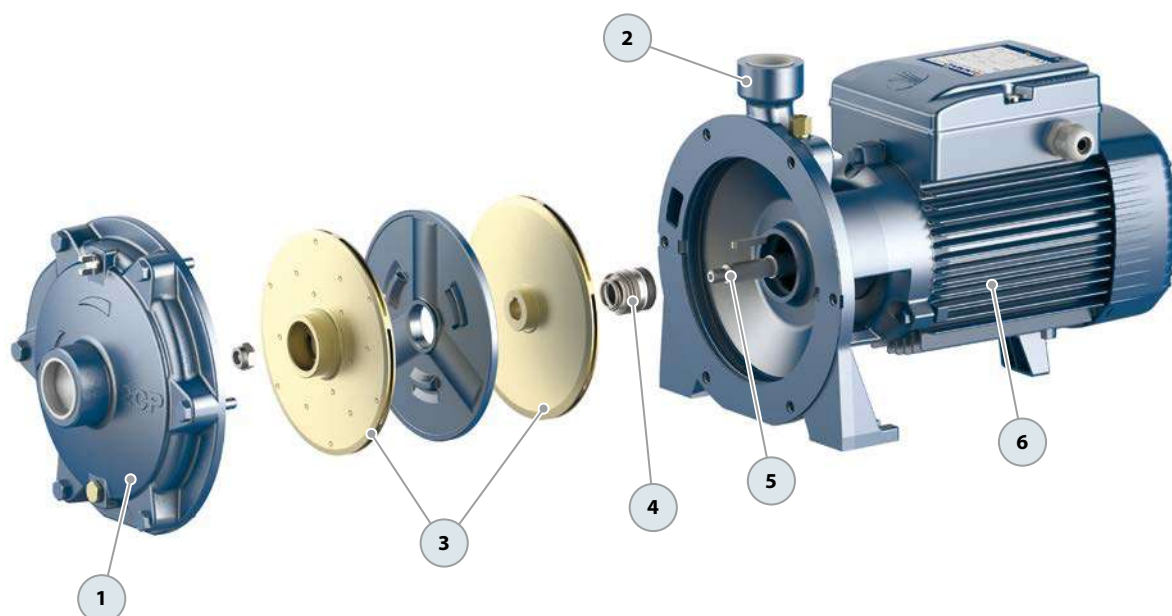



※ Particularly quiet, energy-efficient multi-stage pumps equipped with stainless steel impeller

PERFORMANCE RANGE

- Flow rate up to **130 l/min** (7.8 m³/h)
- Head up to **67 m**

INSTALLATION AND USE

They are recommended for pumping clean water and chemically non-aggressive liquids for the pump materials.

Due to their reliability and quietness, they are widely used in the domestic sector and especially for water distribution coupled with small or medium-sized autoclave tanks, for irrigating vegetable gardens or orchards, etc.

ELECTRIC MOTOR

Three-phase pumps are equipped with high-efficiency motors (IEC 60034-30-1).

Efficiency class **IE3** for three-phase motors and **IE2** for single-phase motors, with class F insulation and IPX4 protection.

APPLICATION LIMITS

- Manometric suction head up to **7 m**
- Liquid temperature between **-10 °C** and **+60 °C**
- Ambient temperature up to **+40 °C**
- Maximum working pressure **6 bar**

PATENTS - TRADE MARKS - MODELS

- Registered Community Model No. 002073635-0001

AVAILABLE UPON REQUEST

- ※ Technopolymer impeller (cost-effective version)
- ※ Different voltage requirements 60 Hz frequency

CURVES AND PERFORMANCE DATA – HS=0 m

50 Hz

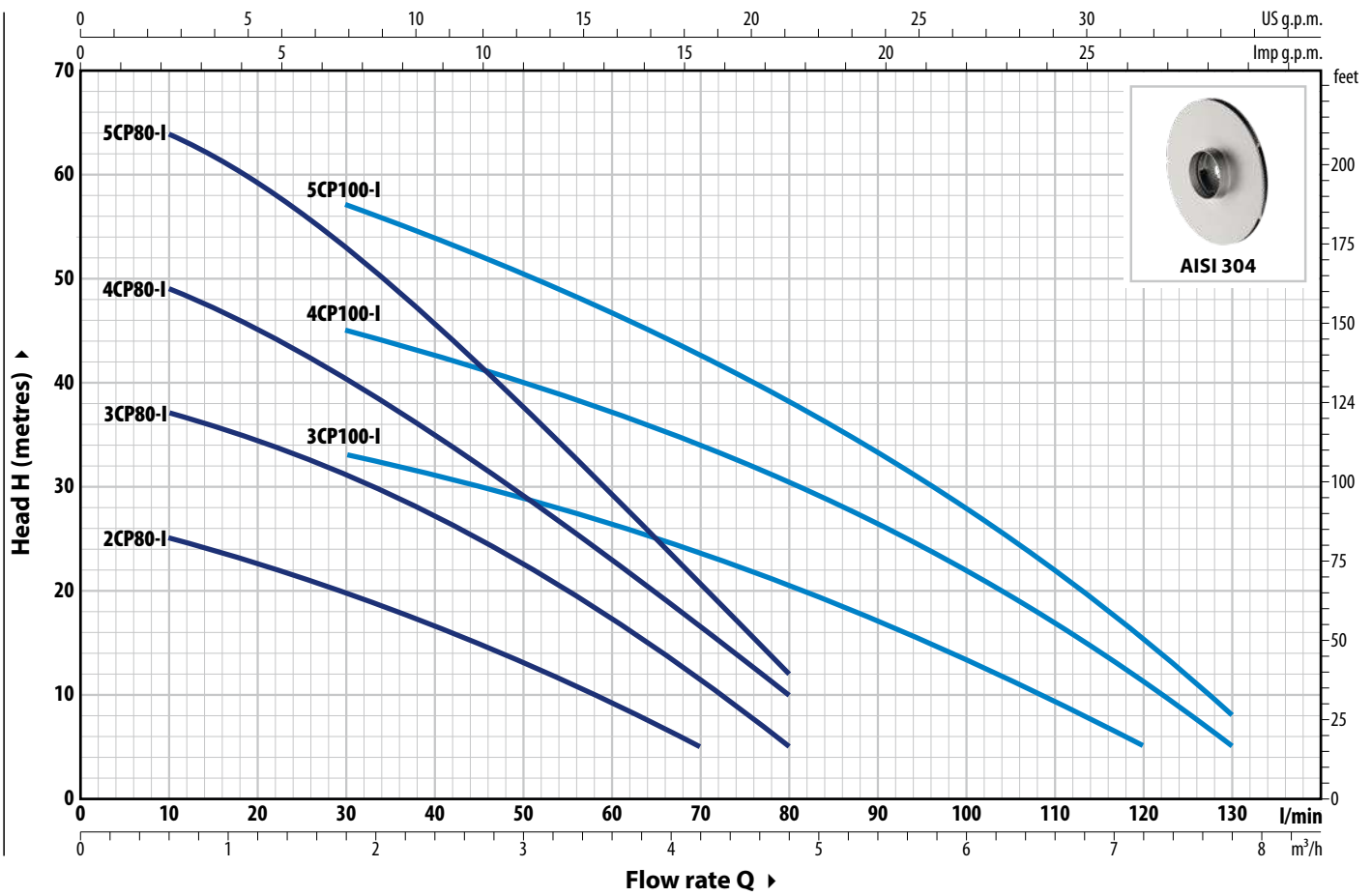

TYPE		POWER (P ₂)		1~3~	Q	H metres																
Single-ph.	Three-ph.	kW	HP			0	0.3	0.6	1.2	1.8	2.4	3.0	3.6	4.2	4.8	5.4	6.0	6.6	7.2	7.8		
						0	5	10	20	30	40	50	60	70	80	90	100	110	120	130		
2CPm 80-I	2CP 80-I	0.30	0.40	IE2 IE3	H metres	27	26	25	22.5	20	16.5	13	9	5								
3CPm 80-I	3CP 80-I	0.45	0.60			40	38	37	34.5	31	27	22.5	17	11	5							
4CPm 80-I	4CP 80-I	0.55	0.75			52	50	49	44.5	40	34	28.5	22.5	16	10							
5CPm 80-I	5CP 80-I	0.75	1			67	66	64	59	53	45.5	37.5	29.5	20.5	12							
3CPm 100-I	3CP 100-I	0.55	0.75			38	37	36	34.5	33	31	28	26	23	20	17	13.5	10	5			
4CPm 100-I	4CP 100-I	0.75	1	50	50	49	47	45	42	39.5	37	34	30.5	26.5	22	17	11	5				
5CPm 100-I	5CP 100-I	0.90	1.25	63	62	61.5	59.5	57	53.5	50.5	46.5	42.5	38	33	28	22	15	8				

Q = Flow rate H = Total manometric head HS = Suction height

Performance curves comply with EN ISO 9906 Grade 3B tolerance limits.

2-5CP - I Technical data

ABSORPTION

TYPE	VOLTAGE
Single-phase	230 V
2CPm 80-I	2.3 A
3CPm 80-I	3.2 A
4CPm 80-I	3.9 A
5CPm 80-I	5.3 A
3CPm 100-I	4.1 A
4CPm 100-I	5.8 A
5CPm 100-I	6.8 A

TYPE	VOLTAGE	
	230 V - Δ	400 V - 人
2CP 80-I	1.7 A	1.0 A
3CP 80-I	2.6 A	1.5 A
4CP 80-I	3.5 A	2.0 A
5CP 80-I	4.3 A	2.5 A
3CP 100-I	3.5 A	2.0 A
4CP 100-I	4.3 A	2.5 A
5CP 100-I	4.3 A	2.5 A

DIMENSIONS AND WEIGHT

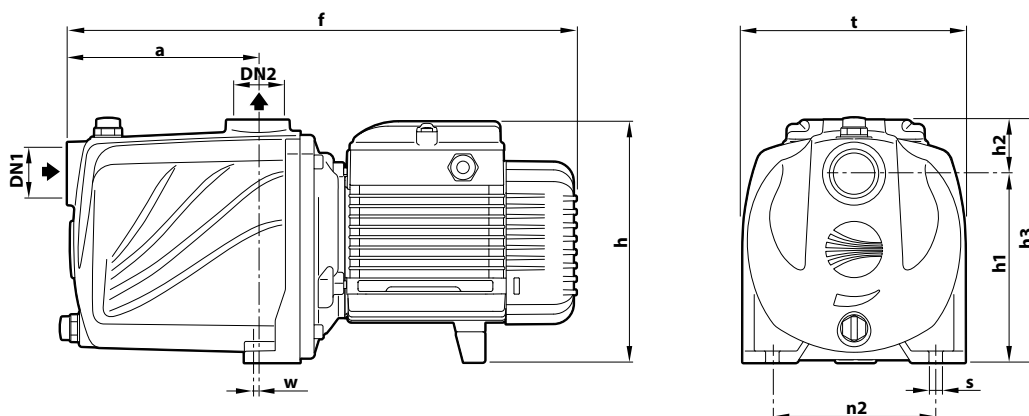

TYPE		PORTS		DIMENSIONS mm										kg	
Single-phase	Three-phase	DN1	DN2	a	f	h	h1	h2	h3	t	n2	w	s	1~	3~
2CPm 80-I	2CP 80-I	1"	1"	110	338	172	134	38	172	158	118	1	10	9.7	9.7
3CPm 80-I	3CP 80-I													10.7	10.7
4CPm 80-I	4CP 80-I			12.2	11.5										
5CPm 80-I	5CP 80-I			15.1	15.1										
3CPm 100-I	3CP 100-I			11.4	10.7										
4CPm 100-I	4CP 100-I			14.9	15.5										
5CPm 100-I	5CP 100-I			14.9	15.7										
				135	382	192 *									

(*) h=221 mm for single-phase 110 V versions

PALLET CAPACITY

TYPE		NO. OF PUMPS
Single-phase	Three-phase	
2CPm 80-I	2CP 80-I	84
3CPm 80-I	3CP 80-I	84
4CPm 80-I	4CP 80-I	84
5CPm 80-I	5CP 80-I	72
3CPm 100-I	3CP 100-I	84
4CPm 100-I	4CP 100-I	72
5CPm 100-I	5CP 100-I	72

MATERIALS AND COMPONENTS

1 Pump body Cast iron with cataphoresis treatment with ISO 228/1 threaded ports

2 Cover Stainless steel **AISI 304**

3 Impellers Stainless steel **AISI 304**

4 Diffusers Noryl™ complete with wear rings

5 Mechanical seal	Seal	Shaft	Materials
	AR-13	Ø 13 mm	Ceramic / Graphite / NBR

6 Motor shaft Stainless steel **AISI 431**

7 Electric motor **2-5CPm -I:** single-phase 230 V - 50 Hz with winding integrated thermal motor protection
2-5CP -I: three-phase 230/400 V - 50 Hz
 ※ Pumps are equipped with high-efficiency motors (IEC 60034-30-1)
 class **IE2** for single-phase models
 class **IE3** for three-phase models
 Continuous running duty **S1**

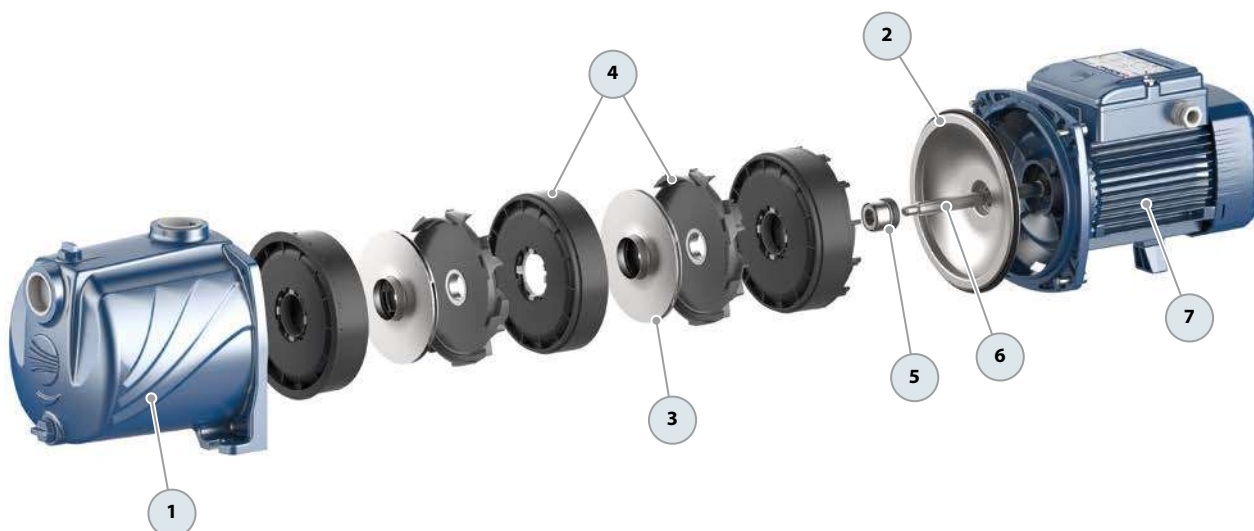

-  Clean water
-  Domestic use
-  Civil use



※ Quiet, energy-efficient stainless steel multi-stage pumps

- ※ Pump body: **Stainless steel AISI 304**
- ※ Cover: **Stainless steel AISI 304**
- ※ Impellers: **Stainless steel AISI 304**
- ※ Shaft: **Stainless steel AISI 431**

PERFORMANCE RANGE

- Flow rate up to **130 l/min** (7.8 m³/h)
- Head up to **67 m**

INSTALLATION AND USE

Designed to transfer clean water free from abrasive particles and liquids that will not damage the pump's components. Highly reliable and quiet, they are suitable for domestic applications.

They work seamlessly with pressure tanks, offering an ideal setup for all irrigation requirements.

ELECTRIC MOTOR

The three-phase pumps are equipped with newly developed electric motors designed to work with inverters, which guarantee stable and quiet operation.

Efficiency class **IE3** for three-phase motors and **IE2** for single-phase motors, with class F insulation and IPX4 protection.

APPLICATION LIMITS

- Manometric suction head up to **7 m**
- Liquid temperature between **-10 °C** and **+60 °C**
- Ambient temperature up to **+40 °C**
- Maximum working pressure **7 bar**

AVAILABLE UPON REQUEST

- ※ Technopolymer impeller (cost-effective version)
- ※ Mechanical seal options available
- ※ Different voltage requirements 60 Hz frequency
- ※ Certified pumps 

CURVES AND PERFORMANCE DATA – HS=0 m

50 Hz

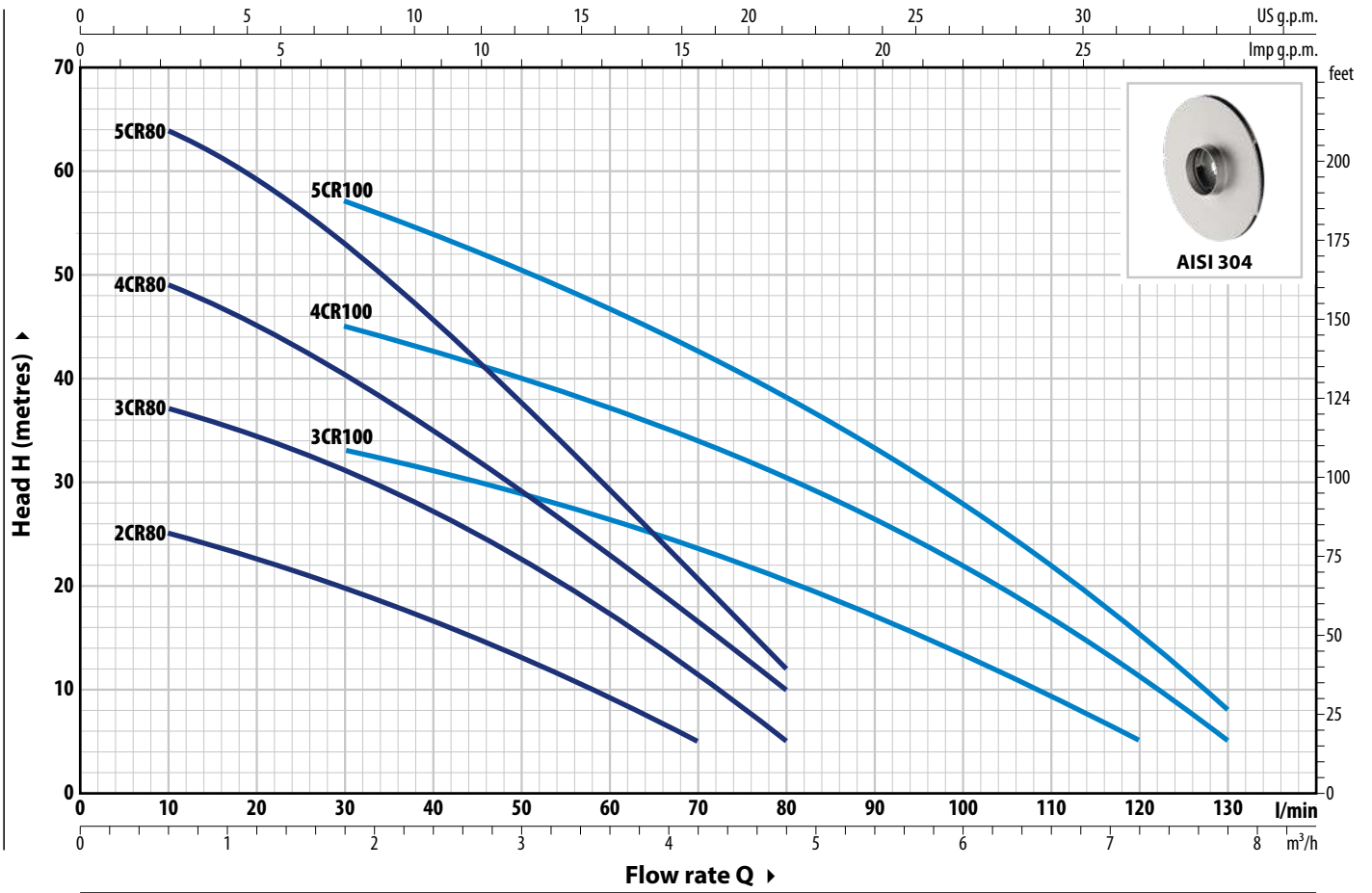

TYPE		POWER (P ₂)		1~3~	Q	H metres																
Single-ph.	Three-ph.	kW	HP			m ³ /h	0	0.3	0.6	1.2	1.8	2.4	3.0	3.6	4.2	4.8	5.4	6.0	6.6	7.2	7.8	
					l/min	0	5	10	20	30	40	50	60	70	80	90	100	110	120	130		
2CRm 80	2CR 80	0.30	0.40	IE2 IE3	H metres	27	26	25	22.5	20	16.5	13	9	5								
3CRm 80	3CR 80	0.45	0.60			40	38	37	34.5	31	27	22.5	17	11	5							
4CRm 80	4CR 80	0.55	0.75			52	50	49	44.5	40	34	28.5	22.5	16	10							
5CRm 80	5CR 80	0.75	1			67	66	64	59	53	45.5	37.5	29.5	20.5	12							
3CRm 100	3CR 100	0.55	0.75			38	37	36	34.5	33	31	28	26	23	20	17	13.5	10	5			
4CRm 100	4CR 100	0.75	1			50	50	49	47	45	42	39.5	37	34	30.5	26.5	22	17	11	5		
5CRm 100	5CR 100	0.90	1.25			63	62	61.5	59.5	57	53.5	50.5	46.5	42.5	38	33	28	22	15	8		

Q = Flow rate H = Total manometric head HS = Suction height

Performance curves comply with EN ISO 9906 Grade 3B tolerance limits.

ABSORPTION

TYPE	VOLTAGE
Single-phase	230 V
2CRm 80	2.2 A
3CRm 80	3.2 A
4CRm 80	3.9 A
5CRm 80	5.5 A
3CRm 100	3.9 A
4CRm 100	5.8 A
5CRm 100	6.8 A

TYPE	VOLTAGE	
	230 V - Δ	400 V - 人
2CR 80	1.7 A	1.0 A
3CR 80	2.6 A	1.5 A
4CR 80	3.5 A	2.0 A
5CR 80	4.3 A	2.5 A
3CR 100	3.5 A	2.0 A
4CR 100	4.0 A	2.3 A
5CR 100	4.3 A	2.5 A

DIMENSIONS AND WEIGHT

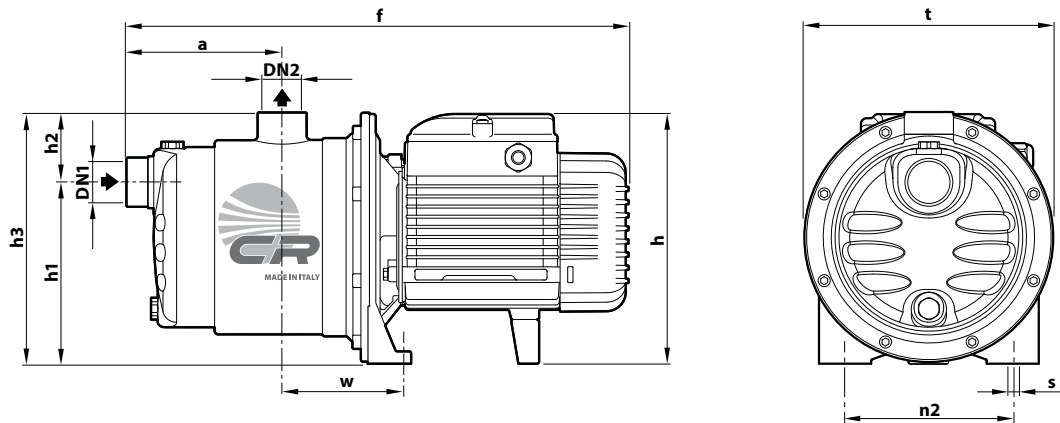

TYPE		PORTS		DIMENSIONS mm										kg	
Single-phase	Three-phase	DN1	DN2	a	f	h	h1	h2	h3	t	n2	w	s	1~	3~
2CRm 80	2CR 80	1"	1"	113	367	182	132	51	183	182	120	87	9	6.9	6.9
3CRm 80	3CR 80													7.9	7.9
4CRm 80	4CR 80			9.1	8.4										
5CRm 80	5CR 80			10	11.8	11.8									
3CRm 100	3CR 100			9	8.6	7.9									
4CRm 100	4CR 100			10	11.6	11.6									
5CRm 100	5CR 100				12.4	11.7									

(*) h=221 mm for single-phase 110V versions

PALLET CAPACITY

TYPE		NO. OF PUMPS
Single-phase	Three-phase	
2CRm 80	2CR 80	84
3CRm 80	3CR 80	84
4CRm 80	4CR 80	72
5CRm 80	5CR 80	72
3CRm 100	3CR 100	84
4CRm 100	4CR 100	72
5CRm 100	5CR 100	72

MATERIALS AND COMPONENTS

1 Pump body	Stainless steel AISI 304 , provided with ISO 228/1 threaded ports		
2 Cover	Stainless steel AISI 304		
3 Impellers	Stainless steel AISI 304		
4 Diffusers	Noryl™ complete with wear rings		
5 Mechanical seal	Seal	Shaft	Materials
	AR-13	Ø 13 mm	Ceramic / Graphite / NBR
6 Motor shaft	Stainless steel AISI 431		
7 Electric motor	2-5CRm : single-phase 230 V - 50 Hz with winding integrated thermal motor protection 2-5CR : three-phase 230/400 V - 50 Hz ※ Pumps are equipped with high-efficiency motors (IEC 60034-30-1) class IE2 for single-phase models class IE3 for three-phase models Continuous running duty S1		

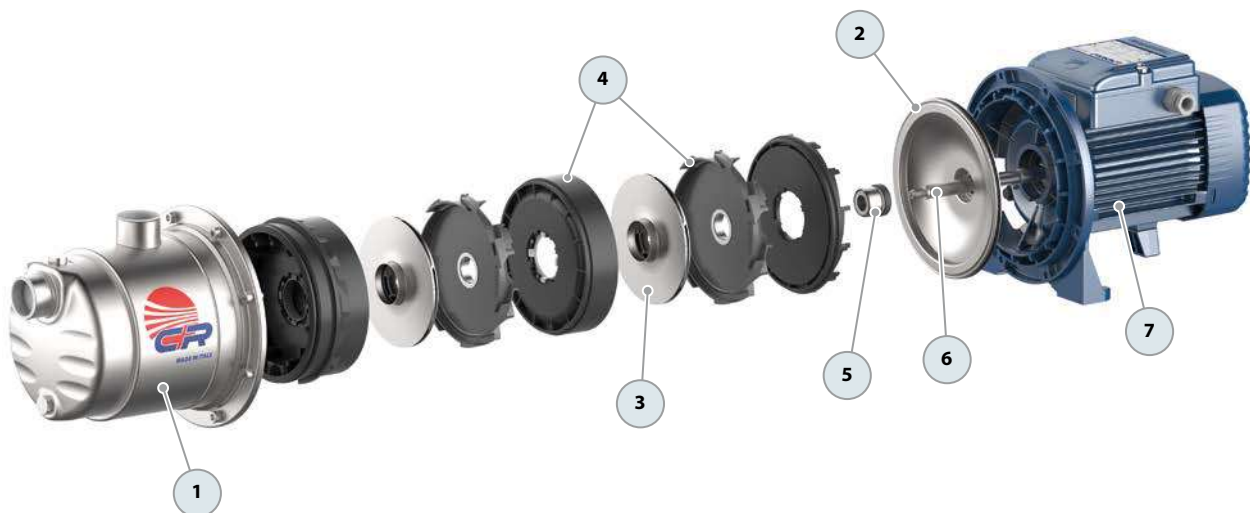

-  Clean water
-  Domestic use
-  Civil use



※ Quiet, energy-efficient stainless steel multi-stage pumps

- ※ Pump body: **Stainless steel AISI 304**
- ※ Cover: **Stainless steel AISI 304**
- ※ Impellers: **Stainless steel AISI 304**
- ※ Shaft: **Stainless steel AISI 431**

PERFORMANCE RANGE

- Flow rate up to **130 l/min** (7.8 m³/h)
- Head up to **67 m**

INSTALLATION AND USE

Quiet performance and efficient energy use make them perfect for water supply and pressurization tasks. They integrate with pressure tanks for optimal water distribution, making them suitable for a wide range of uses from industrial applications to irrigation systems.

ELECTRIC MOTOR

The three-phase pumps are equipped with newly developed electric motors designed to work with inverters, which guarantee stable and quiet operation.

Efficiency class **IE3** for three-phase motors and **IE2** for single-phase motors, with class F insulation and IPX4 protection.

KEY FEATURES

- ※ Stainless steel components extend service life and enhance efficiency.
- ※ Multi-stage design results in exceptionally quiet operation.

APPLICATION LIMITS

- Manometric suction head up to **7 m**
- Liquid temperature between **-10 °C** and **+60 °C**
- Ambient temperature up to **+40 °C**
- Maximum working pressure **7 bar**

AVAILABLE UPON REQUEST

- ※ Mechanical seal options available
- ※ Different voltage requirements 60 Hz frequency
- ※ Certified pumps 

CURVES AND PERFORMANCE DATA – HS=0 m

50 Hz

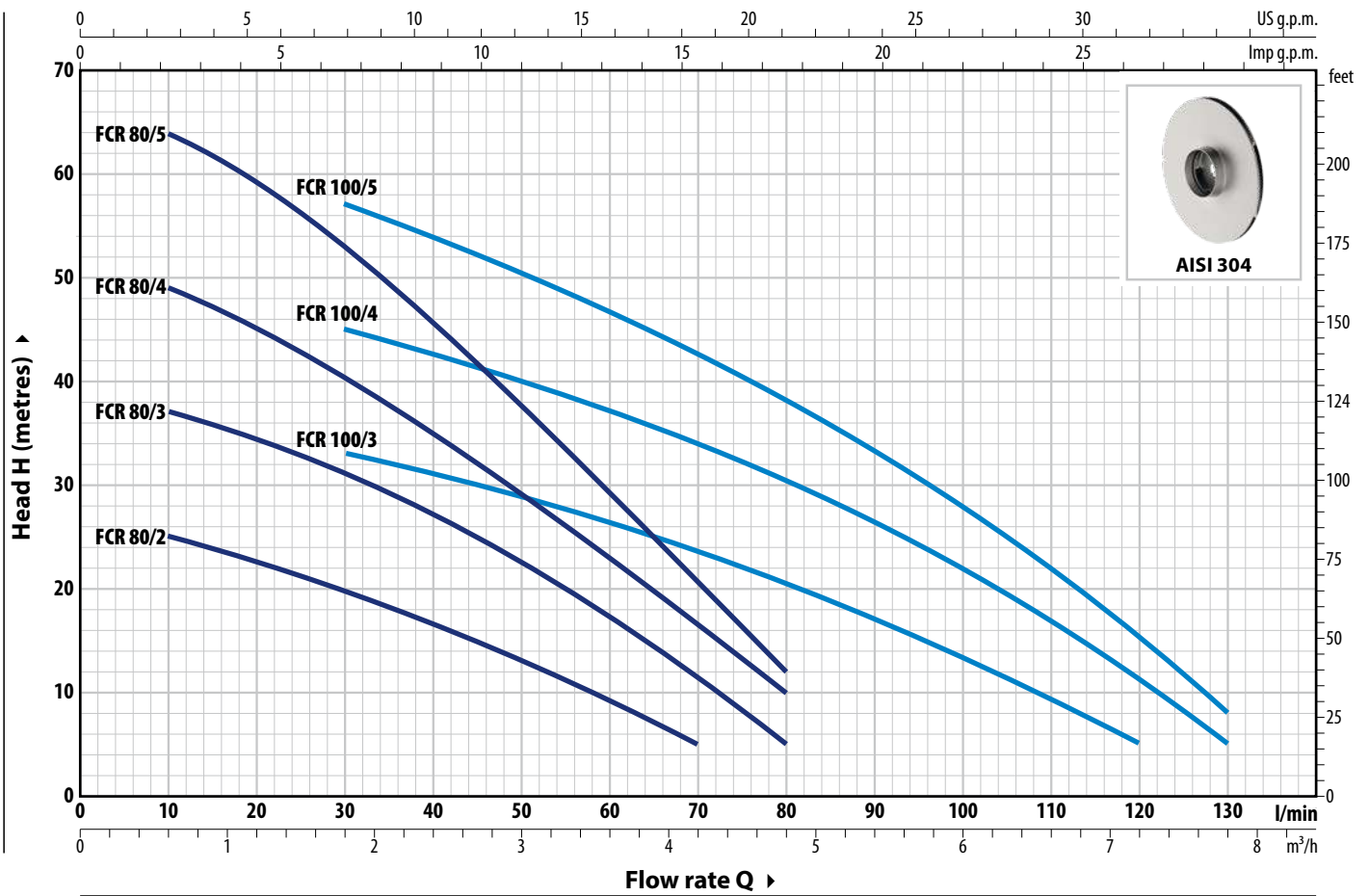

TYPE		POWER (P ₂)		1~3~	Q	H metres																		
Single-ph.	Three-ph.	kW	HP			0	0.3	0.6	0.9	1.2	1.5	1.8	2.4	3.0	3.6	4.2	4.8	5.4	6.0	6.6	7.2	7.8		
						0	5	10	15	20	25	30	40	50	60	70	80	90	100	110	120	130		
FCRm 80/2	FCR 80/2	0.30	0.40	IE2 IE3	H metres	27	26	25	24	22.5	21	20	16.5	13	9	5								
FCRm 80/3	FCR 80/3	0.45	0.60			40	38	37	36	34.5	33	31	27	22.5	17	11	5							
FCRm 80/4	FCR 80/4	0.55	0.75			52	50	49	47	44.5	42	40	34	28.5	22.5	16	10							
FCRm 80/5	FCR 80/5	0.75	1			67	66	64	62	59	56	53	45.5	37.5	29.5	20.5	12							
FCRm 100/3	FCR 100/3	0.55	0.75			38	37	36	35	34.5	33.5	33	31	28	26	23	20	17	13.5	10	5			
FCRm 100/4	FCR 100/4	0.75	1			50	50	49	48	47	46	45	42	39.5	37	34	30.5	26.5	22	17	11	5		
FCRm 100/5	FCR 100/5	0.90	1.25			63	62	61.5	60.5	59.5	58	57	53.5	50.5	46.5	42.5	38	33	28	22	15	8		

Q = Flow rate H = Total manometric head HS = Suction height

Performance curves comply with EN ISO 9906 Grade 3B tolerance limits.

ABSORPTION

TYPE	VOLTAGE
Single-phase	230 V
FCRm 80/2	2.1 A
FCRm 80/3	3.2 A
FCRm 80/4	3.9 A
FCRm 80/5	5.5 A
FCRm 100/3	3.9 A
FCRm 100/4	5.8 A
FCRm 100/5	6.8 A

TYPE	VOLTAGE	
	230 V - Δ	400 V - Y
FCR 80/2	1.6 A	0.9 A
FCR 80/3	2.2 A	1.3 A
FCR 80/4	2.9 A	1.7 A
FCR 80/5	4.0 A	2.3 A
FCR 100/3	2.9 A	1.7 A
FCR 100/4	4.0 A	2.3 A
FCR 100/5	4.3 A	2.5 A

DIMENSIONS AND WEIGHT

WITH THREADED PORTS

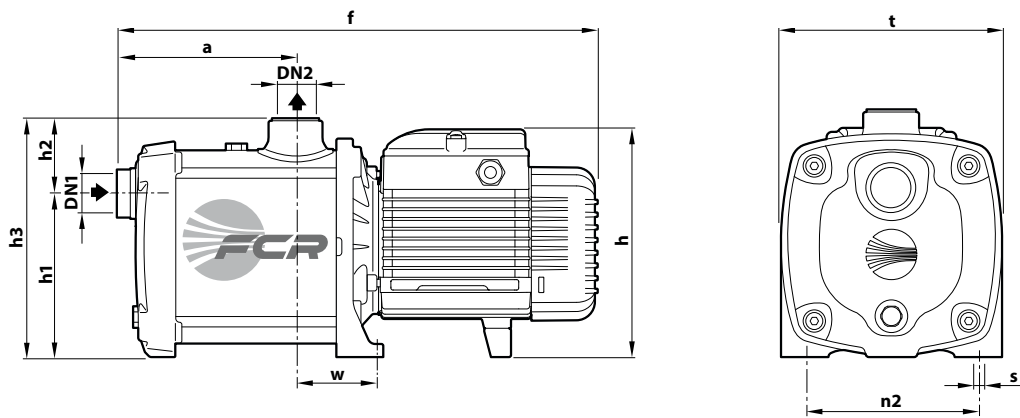

MODEL		PORTS		DIMENSIONS mm										kg	
Single-ph.	Three-ph.	DN1	DN2	a	f	h	h1	h2	h3	t	n2	w	s	1~	3~
FCRm 80/2	FCR 80/2	1"	1"	107	333	171	122	56	178	160	125	56.5	9	6.9	6.9
FCRm 80/3	FCR 80/3													7.9	7.9
FCRm 80/4	FCR 80/4			132	358	189								9.3	9.1
FCRm 80/5	FCR 80/5				377									11.8	11.8
FCRm 100/3	FCR 100/3			107	333	171								8.8	8.1
FCRm 100/4	FCR 100/4			132	377	189								11.6	11.6
FCRm 100/5	FCR 100/5	12.4	12.1												

WITH FLANGED PORTS

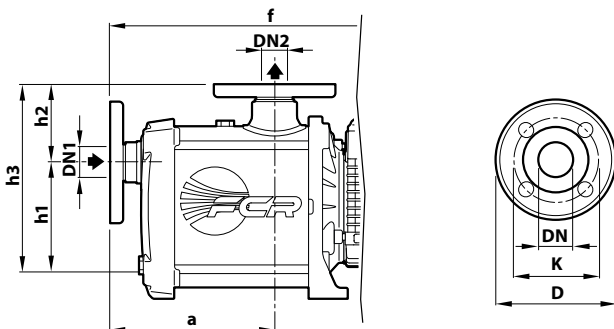

TYPE	PORTS		DIMENSIONS mm						
	DN1	DN2	a	f	h1	h2	h3		
FCR 80/2	25	25	129	355	122	78	200		
FCR 80/3				380					
FCR 80/4			154	399					
FCR 80/5				129				355	
FCR 100/3			154	399					
FCR 100/4									
FCR 100/5									

FLANGE	D	K	HOLES	
			N°	Ø (mm)
DN 25	85	115	4	14
25	85	115	4	14

MATERIALS AND COMPONENTS

1 Pump body	Stainless steel AISI 304 , provided with ISO 228/1 threaded ports		
2 Cover	Stainless steel AISI 304		
3 Impellers	Stainless steel AISI 304		
4 Diffusers	Noryl™ complete with wear rings		
5 Mechanical seal	Seal	Shaft	Materials
	AR-13	Ø 13 mm	Ceramic / Graphite / NBR
6 Motor shaft	Stainless steel AISI 431		
7 Electric motor	<p>FCRm: single-phase 230 V - 50 Hz with winding integrated thermal motor protection</p> <p>FCR: three-phase 230/400 V - 50 Hz</p> <p>※ Pumps are equipped with high-efficiency motors (IEC 60034-30-1)</p> <p>class IE2 for single-phase models</p> <p>class IE3 for three-phase models</p> <p>Continuous running duty S1</p>		

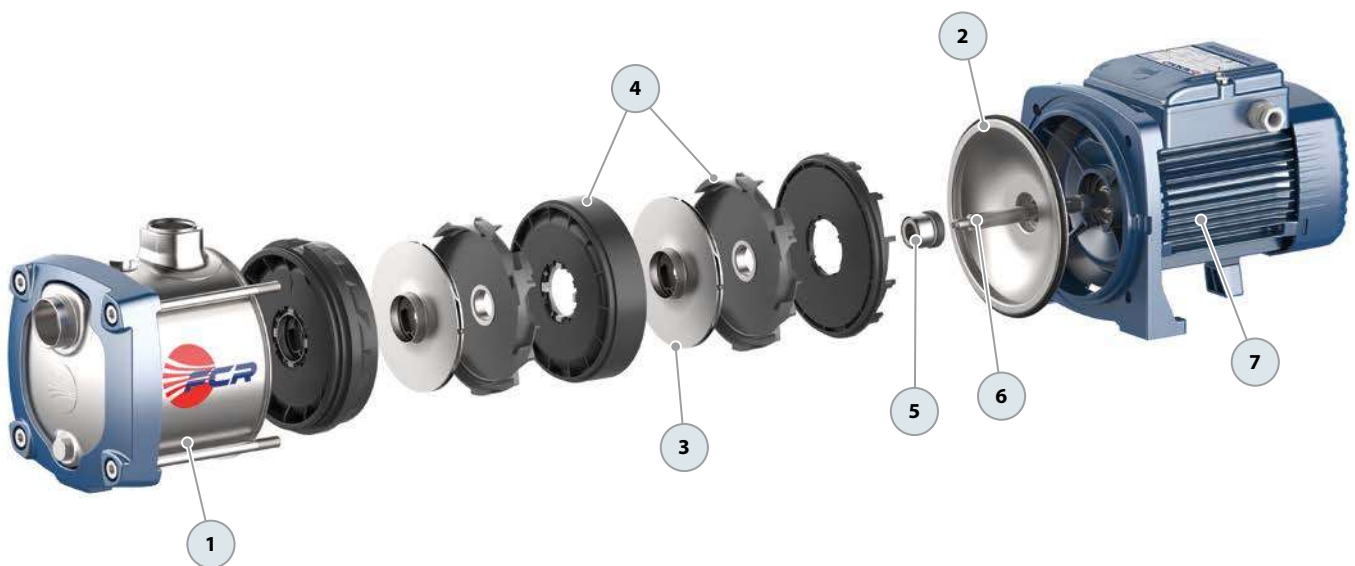

-  Clean water
-  Domestic use
-  Civil use



※ Quiet, energy-efficient stainless steel multi-stage pumps

- ※ Pump body: **Stainless steel AISI 304**
- ※ Cover: **Stainless steel AISI 304**
- ※ Diffusers: **Stainless steel AISI 304**
- ※ Impellers: **Stainless steel AISI 304**
- ※ Shaft: **Stainless steel AISI 431**

PERFORMANCE RANGE

- Flow rate up to **240 l/min** (14.4 m³/h)
- Head up to **133 m**

INSTALLATION AND USE

Designed to transfer clean water free from abrasive particles and safe liquids that will not damage any of the pump's components. Highly reliable and quiet, they are suitable for domestic applications.

They work seamlessly with small to medium-sized pressure tanks, offering an ideal setup for all irrigation requirements.

ELECTRIC MOTOR

The three-phase pumps are equipped with newly developed electric motors designed to work with inverters, which guarantee stable and quiet operation.

Efficiency class **IE3** for three-phase motors and **IE2** for single-phase motors, with class F insulation and IPX4 protection.

KEY FEATURES

- ※ Stainless steel components extend service life and enhance efficiency.
- ※ Multi-stage design results in exceptionally quiet operation.

APPLICATION LIMITS

- Manometric suction head up to **7 m**
- Liquid temperature between **-10 °C** and **+90 °C**
- Ambient temperature up to **+40 °C**
- Maximum working pressure **11 bar**

AVAILABLE UPON REQUEST

- ※ Technopolymer impeller (cost-effective version)
- ※ Mechanical seal options available
- ※ Different voltage requirements 60 Hz frequency
- ※ IPX5 protection
- ※ Certified pumps 
- ※ ISO 228/1 standard flanges for suction and discharge openings, made of AISI 304 stainless steel



CURVES AND PERFORMANCE DATA – HS=0 m

50 Hz

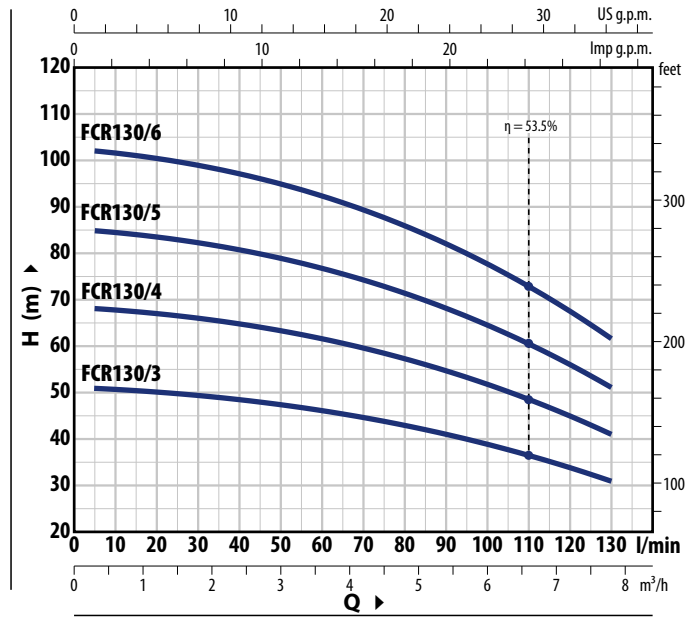
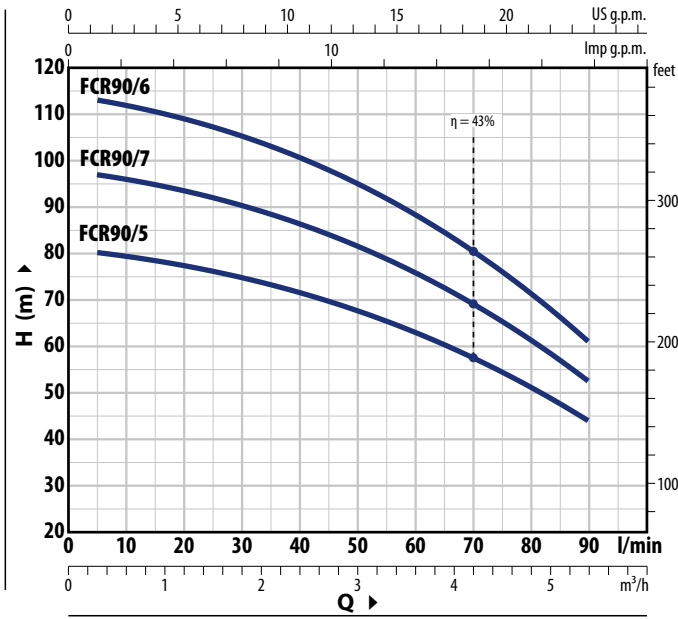

TYPE		POWER (P ₂)		1~3~	Q	m ³ /h										
Single-ph.	Three-ph.	kW	HP			0	0.3	0.6	1.2	2.4	3.6	4.8	5.4	6.0	7.8	
FCRm 90/5	FCR 90/5	1.1	1.5	IE2 IE3	H metres	0	5	10	20	40	60	80	90	100	130	
FCRm 90/6	FCR 90/6	1.5	2			81	80	79	77	71	62.5	51	44			
FCRm 90/7	FCR 90/7	1.8	2.5			97	96	95	93	86	75	61	52			
FCRm 130/3	FCR 130/3	1.1	1.5	IE2 IE3	H metres	0	0.3	0.6	1.2	2.4	3.6	4.8	5.4	6.0	7.8	
FCRm 130/4	FCR 130/4	1.5	2			51.5	51.5	51	50.5	49	46.5	43	41	39	31	
FCRm 130/5	FCR 130/5	1.8	2.5			68.5	68.5	68	67	65	62	57.5	55	52	41	
FCRm 130/6	FCR 130/6	2.2	3			86	85	85	84	81	77	72	68.5	65	51.5	
						103	103	102	101	98	93	86	82	78	62	

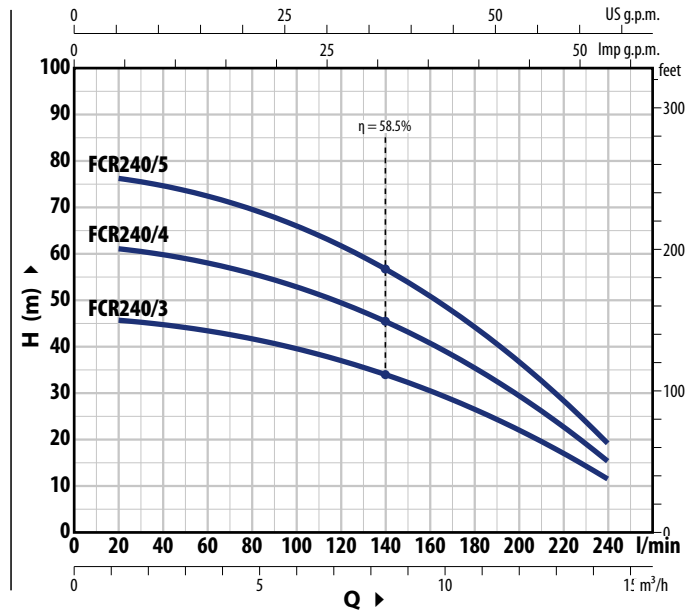
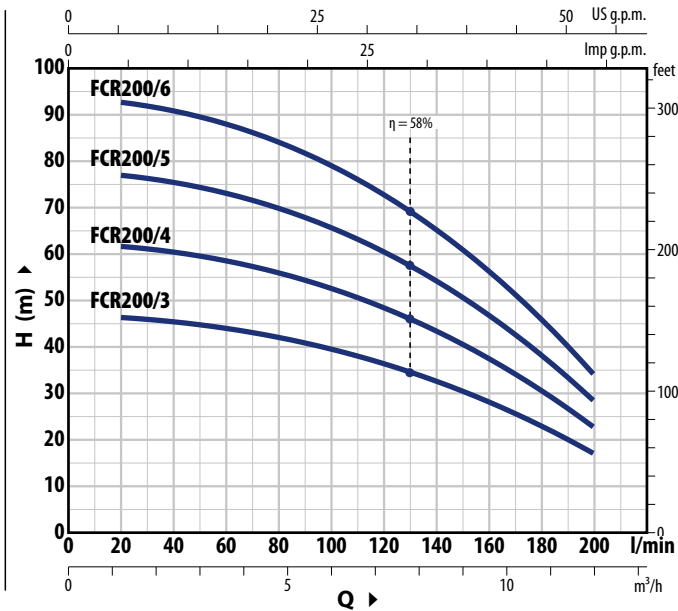

TIPO		POTENZA (P ₂)		1~3~	Q	m ³ /h													
Monofase	Trifase	kW	HP			0	1.2	2.4	3.6	4.8	6.0	7.2	8.4	9.6	10.8	12.0	13.2	14.4	
FCRm 200/3	FCR 200/3	1.1	1.5	IE2 IE3	H metres	0	20	40	60	80	100	120	140	160	180	200	220	240	
FCRm 200/4	FCR 200/4	1.5	2			47	46.5	45.5	44	42	39.5	36.5	32.5	28	23.1	17			
FCRm 200/5	FCR 200/5	1.8	2.5			62.5	62	60.5	58.5	56	53	48.5	43.5	37.5	31	23			
FCRm 200/6	FCR 200/6	2.2	3			78	77.5	76	73	70	66	61	54.5	47	38.5	28.5			
						94	93	91	88	84	79	73	65.5	56.5	46	34.5			
✳ FCRm 240/3	FCR 240/3	1.5	2	IE2 IE3	H metres	0	1.2	2.4	3.6	4.8	6.0	7.2	8.4	9.6	10.8	12.0	13.2	14.4	
✳ FCRm 240/4	FCR 240/4	1.8	2.5			46.5	46	45	43.5	42	39.5	37	34	30.5	26.6	22	17	11.5	
✳ FCRm 240/5	FCR 240/5	2.2	3			62	61	60	58	55.5	53	49.5	45.5	41	35.5	29.5	22.8	15.5	
						77	76.5	75	73	69.5	66	62	57	51	44.5	37	28.5	19	

Q = Portata H = Prevalenza manometrica totale HS = Altezza di aspirazione

Tolleranza delle curve di prestazione secondo EN ISO 9906 Grado 3B.

ABSORPTION

TYPE	VOLTAGE
Single-phase	230 V
FCRm 90/5	9.0 A
FCRm 90/6	10.5 A
FCRm 90/7	12.5 A
FCRm 130/3	8.5 A
FCRm 130/4	10.3 A
FCRm 130/5	12.5 A
FCRm 130/6	13.5 A
FCRm 200/3	8.7 A
FCRm 200/4	10.5 A
FCRm 200/5	12.5 A
FCRm 200/6	14.0 A
FCRm 240/3	8.5 A
FCRm 240/4	10.5 A
FCRm 240/5	12.5 A

TYPE	VOLTAGE	
	230 V - Δ	400 V - Δ
FCR 90/5	6.1 A	3.5 A
FCR 90/6	6.9 A	4.0 A
FCR 90/7	8.3 A	4.8 A
FCR 130/3	5.5 A	3.2 A
FCR 130/4	6.9 A	4.0 A
FCR 130/5	8.6 A	5.0 A
FCR 130/6	9.0 A	5.2 A
FCR 200/3	5.9 A	3.4 A
FCR 200/4	7.3 A	4.2 A
FCR 200/5	8.6 A	5.0 A
FCR 200/6	9.5 A	5.5 A
FCR 240/3	5.7 A	3.3 A
FCR 240/4	7.6 A	4.4 A
FCR 240/5	8.6 A	5.0 A

DIMENSIONS AND WEIGHT

※ WITH THREADED PORTS

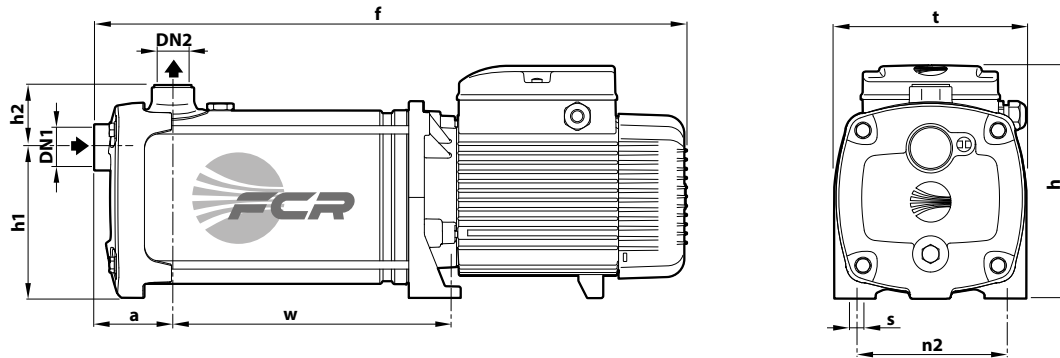

TYPE		PORTS		DIMENSIONS mm									kg	
Single-phase	Three-phase	DN1	DN2	a	f	h	h1	h2	t	n2	w	s	1~	3~
FCRm 90/5	FCR 90/5	1 1/4"	1"	75	492	228	145	59	185	145	191	11	20.0	20.0
FCRm 90/6	FCR 90/6				217						22.0		22.0	
FCRm 90/7	FCR 90/7				564						25.7		25.7	
FCRm 130/3	FCR 130/3				440						18.0		18.0	
FCRm 130/4	FCR 130/4				466						20.2		20.2	
FCRm 130/5	FCR 130/5				512						23.7		23.7	
FCRm 130/6	FCR 130/6				538						24.7		24.7	
FCRm 200/3	FCR 200/3				440						18.0		18.0	
FCRm 200/4	FCR 200/4				466						20.2		20.2	
FCRm 200/5	FCR 200/5				512						23.7		23.7	
FCRm 200/6	FCR 200/6				538						24.7		24.7	
FCRm 240/3	FCR 240/3				440						19.2		19.2	
FCRm 240/4	FCR 240/4				486						22.7		22.7	
FCRm 240/5	FCR 240/5				512						23.7		23.7	

※ WITH FLANGED PORTS

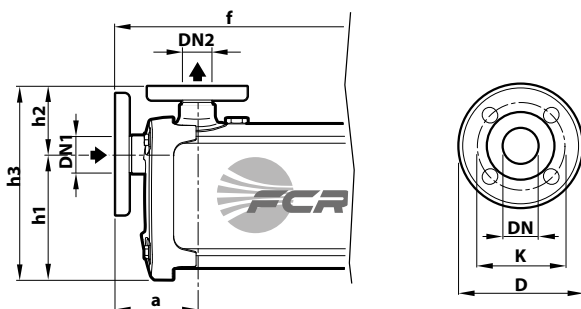

TYPE	PORTS		DIMENSIONS mm				
	DN1	DN2	a	f	h1	h2	h3
FCR 90/5	25	32	97.5	515	145	82	227
FCR 90/6				541			
FCR 90/7				587			
FCR 130/3				463			
FCR 130/4				489			
FCR 130/5				535			
FCR 130/6				561			
FCR 200/3				463			
FCR 200/4				489			
FCR 200/5				535			
FCR 200/6				561			
FCR 240/3				463			
FCR 240/4				509			
FCR 240/5				535			

FLANGES DN	D (mm)	K (mm)	N° HOLES	Ø (mm)
25	85	115	4	14
32	100	140	4	18

MATERIALS AND COMPONENTS

1 Pump body Stainless steel **AISI 304** with ISO 228/1 threaded ports

2 Cover Stainless steel **AISI 304**

3 Impellers Stainless steel **AISI 304**

4 Diffusers Stainless steel **AISI 304**

5 Mechanical seal	Seal	Shaft	Materials
	FN-18	Ø 18 mm	Graphite / Ceramic / NBR

6 Motor shaft Stainless steel **AISI 431**

7 Electric motor **FCRm**: single-phase 230 V - 50 Hz with winding integrated thermal motor protection
FCR: three-phase 230/400 V - 50 Hz
 ※ Pumps are equipped with high-efficiency motors (IEC 60034-30-1)
 class **IE2** for single-phase models
 class **IE3** for three-phase models
 Continuous running duty **S1**

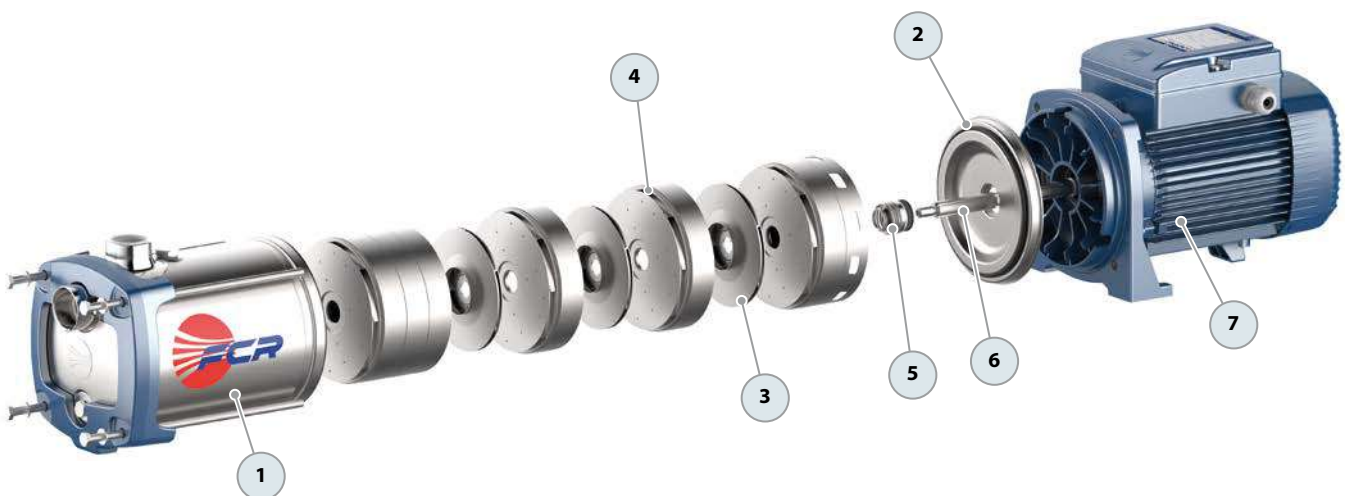

-  Clean water
-  Civil use
-  Industrial use



※ Low noise, low energy stainless steel multi-stage pumps

- ※ Pump body: **Stainless steel AISI 304**
- ※ Cover: **Stainless steel AISI 304**
- ※ Diffusers: **Stainless steel AISI304**
- ※ Impellers: **Stainless steel AISI 304**
- ※ Shaft: **Stainless steel AISI 431**

PERFORMANCE RANGE

- Flow rate up to **800 l/min** (48 m³/h)
- Head up to **120 m**

INSTALLATION AND USE

Due to their silent operation and energy efficiency, these pumps are ideal for water supply and pressurization, water distribution in conjunction with autoclaves, industrial uses, and irrigation systems.

ELECTRIC MOTOR

The three-phase pumps are equipped with newly developed electric motors designed to work with inverters, which guarantee stable and quiet operation.

Efficiency class **IE3**, class F insulation and IP55 protection.

KEY FEATURES

- ※ Stainless steel components extend service life and enhance efficiency.
- ※ Multi-stage design results in exceptionally quiet operation.

APPLICATION LIMITS

- Manometric suction head up to **7 m**
- Liquid temperature between **-15 °C** and **+90 °C**
- Ambient temperature up to **+40 °C**
- Maximum working pressure **12 bar**

AVAILABLE UPON REQUEST

- ※ AISI 316 stainless steel pump.
- ※ Handling of liquids with higher or lower temperatures.
- ※ Different voltage requirements 60 Hz frequency
- ※ **WRAS-certified** pumps
- ※ ISO 228/1 standard flanges for suction and discharge openings, made of AISI 304 stainless steel.



FCR 15

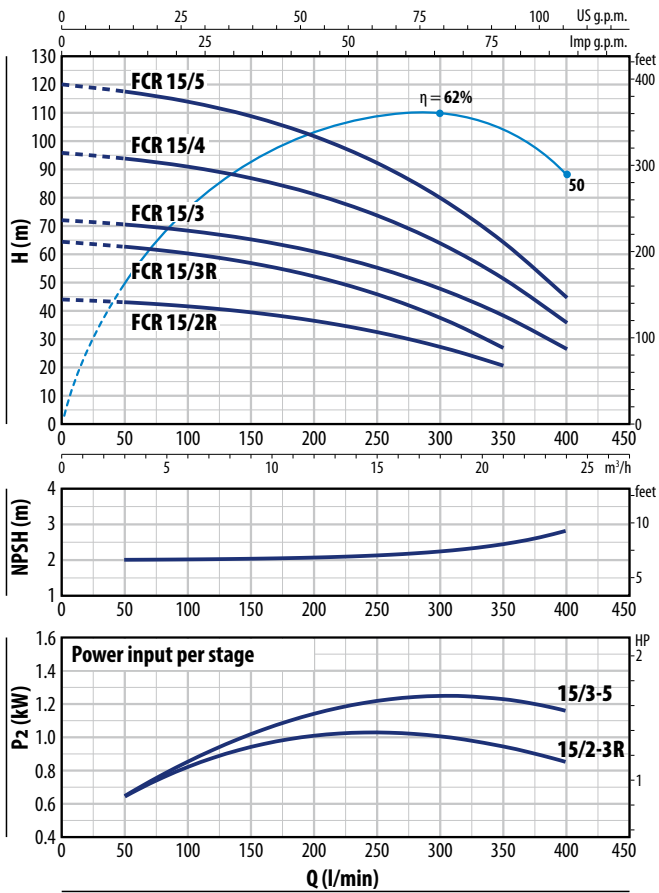

FCR 30

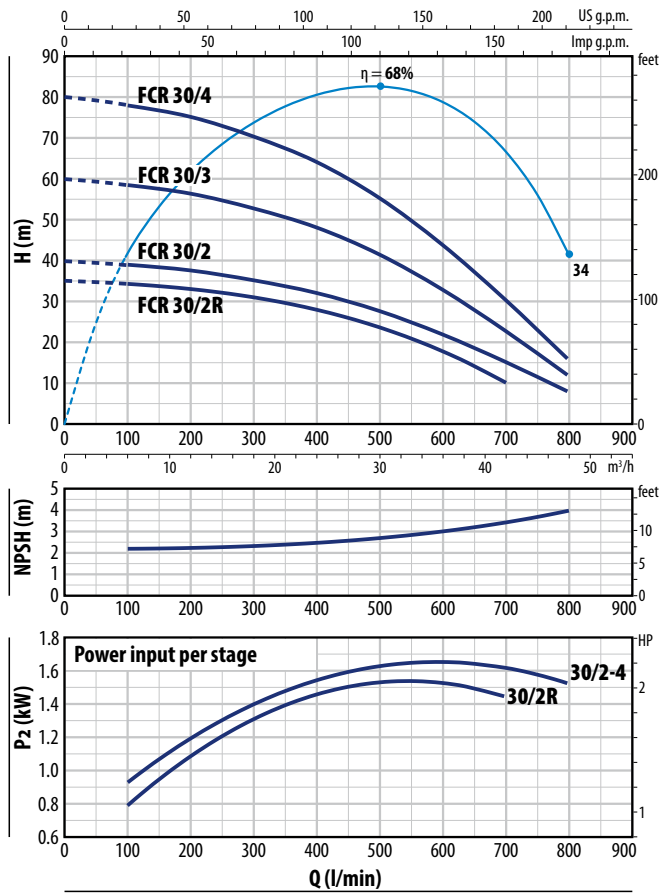

FCR 15

TYPE	POWER (P ₂)		Q	Q							
	kW	HP		m ³ /h	0	3	6	12	18	21	24
Three-phase			3~	0	50	100	200	300	350	400	
FCR 15/2R	2.2	3	IE3 H metres	44	43	41.5	36.5	27.5	20.5		
FCR 15/3R	3	4		64.5	62.5	60.5	52.0	37.5	27		
FCR 15/3	4	5.5		72	70	68.5	61	48	38.5	27	
FCR 15/4	5.5	7.5		96	94	91	81	64	51.5	36	
FCR 15/5	7.5	10		120	117	114	102	80	64.5	45	

FCR 30

TYPE	POWER (P ₂)		Q	Q							
	kW	HP		m ³ /h	0	6	12	18	24	36	42
Three-phase			3~	0	100	200	300	400	600	700	800
FCR 30/2R	3	4	IE3 H metres	35	34	33	31	28	17.6	10	
FCR 30/2	4	5.5		40	39	37.5	35	31.5	22	15.7	8
FCR 30/3	5.5	7.5		60	58.5	56	52.5	47.5	33	23.5	12
FCR 30/4	7.5	10		80	78	75	70	63	44	31.3	16

Q = Flow rate H = Total manometric head HS = Suction height

Performance curves comply with EN ISO 9906 Grade 3B tolerance limits.

ABSORPTION

TYPE	VOLTAGE			
	230 V - Δ	400 V - Δ	400 V - Δ	690 V - Δ
Three-ph.				
FCR 15/2R	10.4 A	6.0 A	-	-
FCR 15/3R	12.5 A	7.2 A	-	-
FCR 15/3	15.2 A	8.8 A	-	-
FCR 15/4	-	-	11.2 A	6.5 A
FCR 15/5	-	-	14.2 A	8.2 A

TYPE	VOLTAGE			
	230 V - Δ	400 V - Δ	400 V - Δ	690 V - Δ
Three-ph.				
FCR 30/2R	12.1 A	7.0 A	-	-
FCR 30/2	15.2 A	8.8 A	-	-
FCR 30/3	-	-	11.2 A	6.5 A
FCR 30/4	-	-	14.1 A	8.2 A

DIMENSIONS AND WEIGHT

※ WITH THREADED PORTS

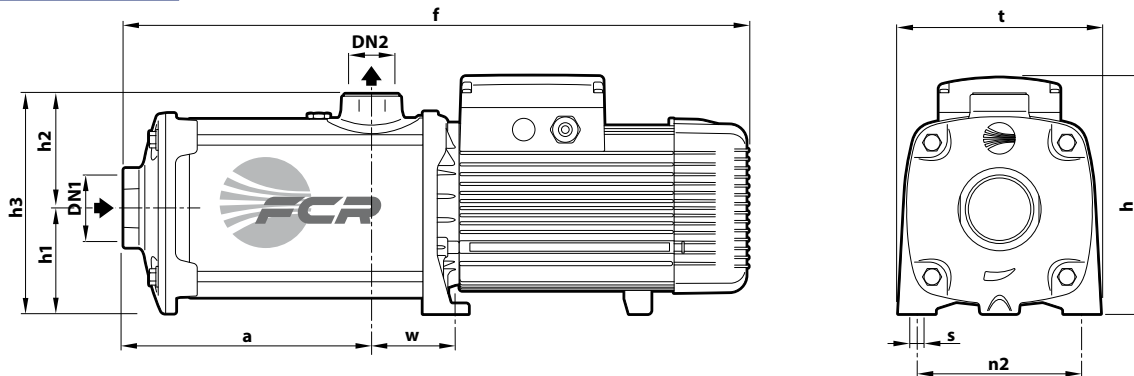

TYPE	PORTS		N° STAGES	DIMENSIONS mm										kg 3~
	DN1	DN2		a	f	h	h1	h2	h3	t	n2	w	s	
Three-phase														
FCR 15/2R	2½"	2"	2	155	533	271	120	132	252	234	190	96	12	34.0
FCR 15/3R			3	199	577									40.0
FCR 15/3			3	243	621									40.0
FCR 15/4			4	287	715									46.0
FCR 15/5			5	287	715									57.0
FCR 30/2R	2½"	2"	2	155	533	271	120	132	252	234	190	96	12	37.0
FCR 30/2			2	199	577									37.0
FCR 30/3			3	243	621									44.0
FCR 30/4			4	287	715									54.0

※ WITH FLANGED PORTS

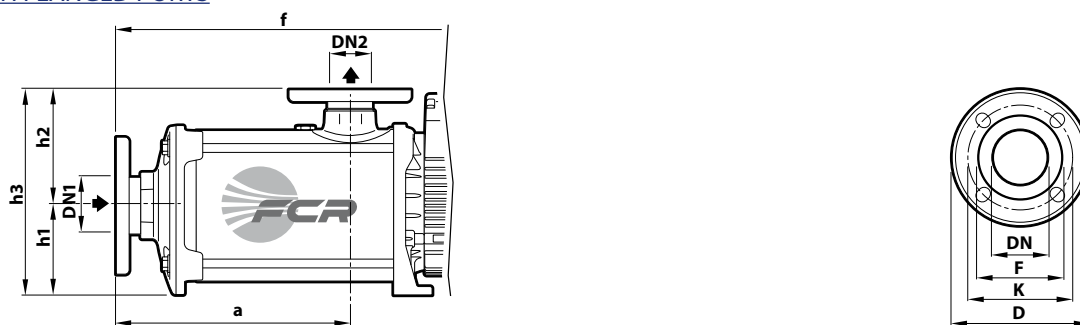

TYPE	PORTS		DIMENSIONS mm				
	DN1	DN2	a	f	h1	h2	h3
Three-phase							
FCR 15/2R	65	50	189	566	120	165	285
FCR 15/3R			233	610			
FCR 15/3			277	654			
FCR 15/4			320	748			
FCR 15/5			320	748			
FCR 30/2R	65	50	189	566	120	165	285
FCR 30/2			233	610			
FCR 30/3			276	704			
FCR 30/4			276	704			

FLANGE DN	D	K	F	HOLES	
	mm	mm	mm	N°	Ø (mm)
50	165	125	99	4	18
65	185	145	118	4	18

MATERIALS AND COMPONENTS

1 Pump body Stainless steel **AISI 304**, provided with ISO 228/1 threaded ports

2 Cover Stainless steel **AISI 304**

3 Impellers Stainless steel **AISI 304**

4 Diffusers Stainless steel **AISI 304**

5 Mechanical seal	Seal	Shaft	Materials
	FN-KU-24 ISO 3069 EN 12756	Ø 24 mm	Graphite / Ceramic / NBR

6 Pump shaft Stainless steel **AISI 316L**

7 Electric motor **Three-phase** 230/400 V - 50 Hz up to 4 kW
400/690 V - 50 Hz 5.5 to 7.5 kW
※ The pumps are equipped with high-efficiency motors (IEC 60034-30-1) class **IE3**
Continuous running duty **S1**

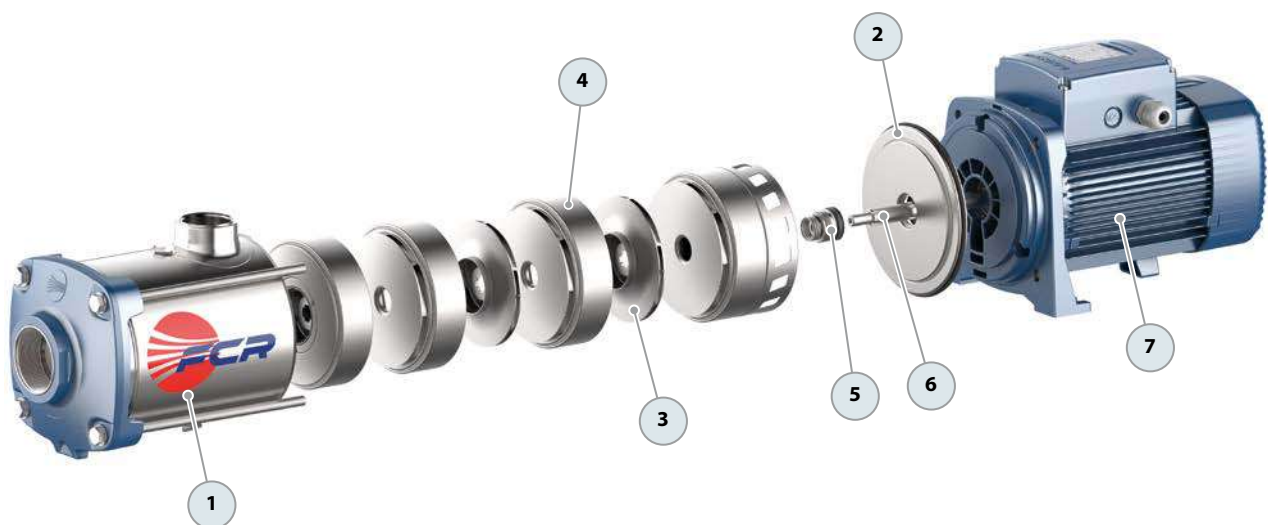

-  Clean water
-  Domestic use
-  Civil use
-  Agricultural use



PERFORMANCE RANGE

- Flow rate up to **180 l/min** (10.8 m³/h)
- Head up to **114 m**

INSTALLATION AND USE

Compact and cost-effective vertical multistage centrifugal pumps suitable for water supply, clean liquids, and pressurization in domestic, civil, and agricultural systems, as well as irrigation.

ELECTRIC MOTOR

The three-phase pumps are equipped with newly developed electric motors designed to work with inverters, which guarantee stable and quiet operation.

Efficiency class **IE3** for three-phase motors and **IE2** for single-phase motors, with class F insulation and IPX4 protection.

APPLICATION LIMITS

- Manometric suction head up to **7 m**
- Liquid temperature between **-10 °C** and **+60 °C**
- Ambient temperature up to **+40 °C**
- Maximum working pressure **11 bar**

AVAILABLE UPON REQUEST

- ✘ Different voltage requirements 60 Hz frequency

CURVES AND PERFORMANCE DATA – HS=0 m

50 Hz

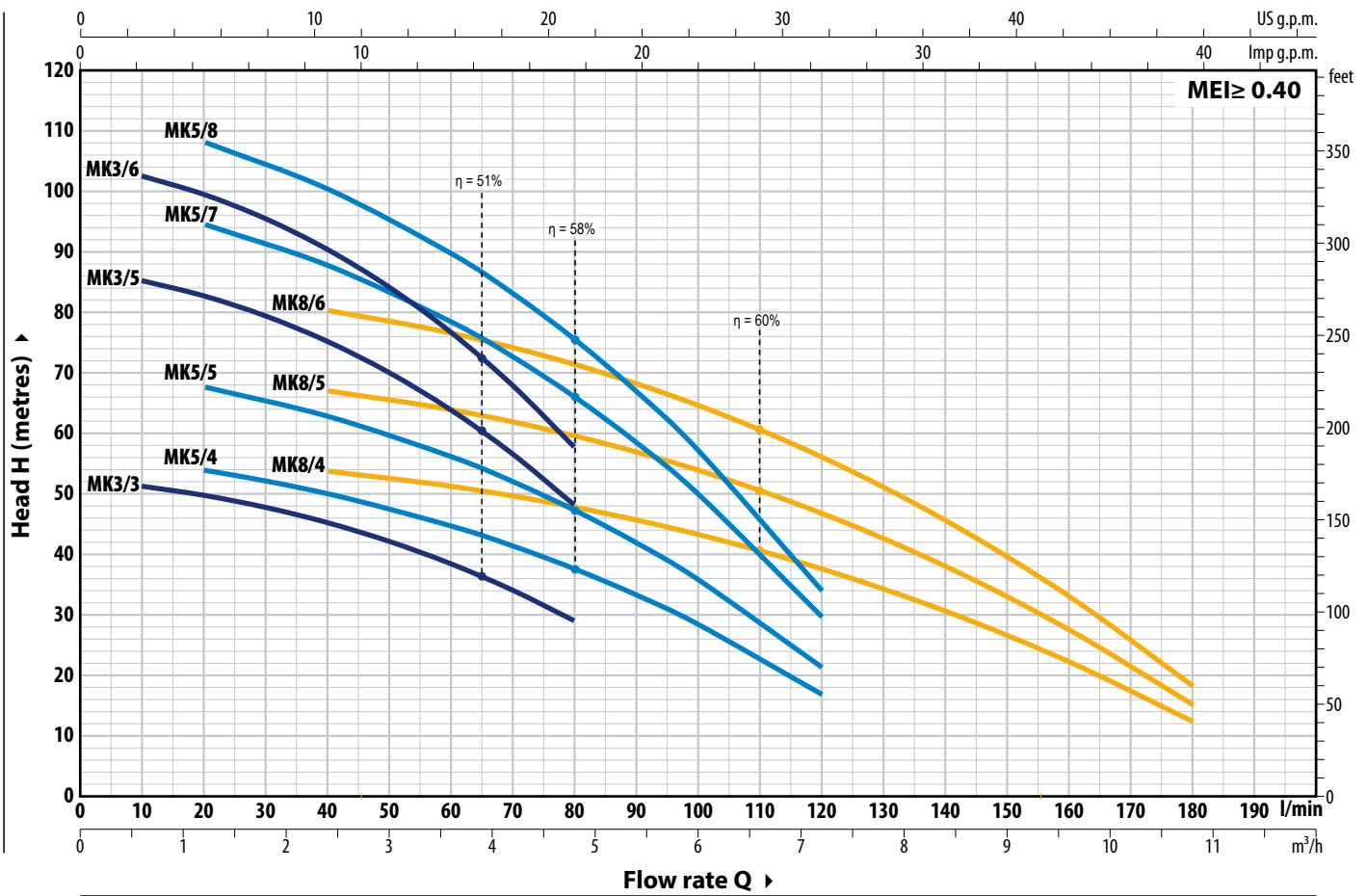

TYPE		POWER (P ₂)		1~3~	Q	H metres											
Single-ph.	Three-ph.	kW	HP			m ³ /h	0	0.6	1.2	2.4	3.6	4.8	6.0	7.2	8.4	9.6	10.8
					l/min	0	10	20	40	60	80	100	120	140	160	180	
MKm 3/3	MK 3/3	0.75	1	IE2 IE3		52.5	51.5	50	45	38.5	29						
MKm 3/5	MK 3/5	1.1	1.5			87	85	83	75	64	48						
MKm 3/6	MK 3/6	1.5	2			105	103	100	90	77	58						
MKm 5/4	MK 5/4	0.75	1			57	–	54	50	45	37.5	28.5	17				
MKm 5/5	MK 5/5	1.1	1.5			71	–	67.5	62.5	56	47	35.5	21.5				
MKm 5/7	MK 5/7	1.5	2			99	–	95	88	78	66	50	30				
MKm 5/8	MK 5/8	2.2	3			114	–	108	100	90	75	57	34				
MKm 8/4	MK 8/4	1.1	1.5			56	–	–	53.5	51	47.5	43	37.5	30.5	22.1	12	
MKm 8/5	MK 8/5	1.5	2			70	–	–	67	64	59.5	54	47	38	27.5	15.5	
MKm 8/6	MK 8/6	2.2	3		84	–	–	80	77	72	64.5	56	45.5	33	18.5		

Q = Flow rate H = Total manometric head HS = Suction height

Performance curves comply with EN ISO 9906 Grade 3B tolerance limits.

ABSORPTION

TYPE	VOLTAGE
Single-ph.	230 V
MKm 3/3	5.7 A
MKm 3/5	7.8 A
MKm 3/6	9.5 A
MKm 5/4	5.7 A
MKm 5/5	7.1 A
MKm 5/7	9.3 A
MKm 5/8	10.0 A
MKm 8/4	7.8 A
MKm 8/5	9.7 A
MKm 8/6	11.1 A

TYPE	VOLTAGE	
Three-ph.	230 V - Δ	400 V - ƿ
MK 3/3	4.2 A	2.4 A
MK 3/5	5.2 A	3.0 A
MK 3/6	6.1 A	3.5 A
MK 5/4	4.3 A	2.5 A
MK 5/5	4.7 A	2.7 A
MK 5/7	6.1 A	3.5 A
MK 5/8	7.4 A	4.3 A
MK 8/4	5.2 A	3.0 A
MK 8/5	6.1 A	3.5 A
MK 8/6	7.8 A	4.5 A

DIMENSIONS AND WEIGHT

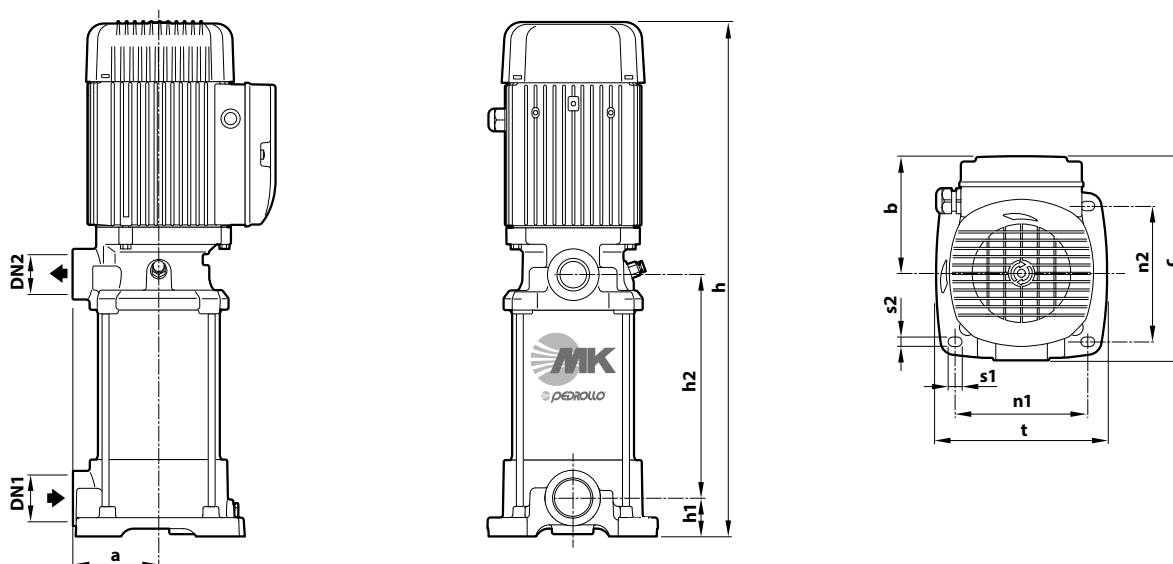

TYPE		PORTS		DIMENSIONS mm										kg		
Single-ph.	Three-ph.	DN1	DN2	a	h	h1	h2	n1	n2	t	b	c	s1	s2	1~	3~
MKm 3/3	MK 3/3	1 1/4"	1"	93	447	41.5	132.5	143	146	185	127	220	14.5	10	21.3	20.0
MKm 3/5	MK 3/5				501		186.5								22.2	22.2
MKm 3/6	MK 3/6				528		213.5								24.0	24.0
MKm 5/4	MK 5/4				474		159.5								21.8	20.5
MKm 5/5	MK 5/5				501		186.5								21.9	22.0
MKm 5/7	MK 5/7				555		240.5								24.6	24.2
MKm 5/8	MK 5/8				602		267.5								25.5	24.5
MKm 8/4	MK 8/4				474		159.5								22.7	22.7
MKm 8/5	MK 8/5				501		186.5								23.4	23.0
MKm 8/6	MK 8/6				548		213.5								27.1	26.1

MATERIALS AND COMPONENTS

1 Suction body Cast iron with cathaphoresis treatment, provided with ISO 228/1 threaded suction port

2 External sleeve Stainless steel **AISI 304**

3 Delivery port Cast iron with cathaphoresis treatment, provided with ISO 228/1 threaded delivery port

4 Impellers and diffusers Noryl™

5 Diaphragms. **AISI 304** stainless steel complete with wear rings

6 Mechanical seal

Seal	Shaft	Materials
FN-18	Ø 18 mm	Graphite / Ceramic / NBR

7 Motor shaft Stainless steel **AISI 431**

8 Electric motor

MKm: single-phase 230 V - 50 Hz with capacitor and winding integrated thermal motor protection

MK: three-phase 230/400 V - 50 Hz

※ Pumps are equipped with high-efficiency motors (IEC 60034-30-1)

class **IE2** for single-phase models

class **IE3** for three-phase models

Continuous running duty **S1**

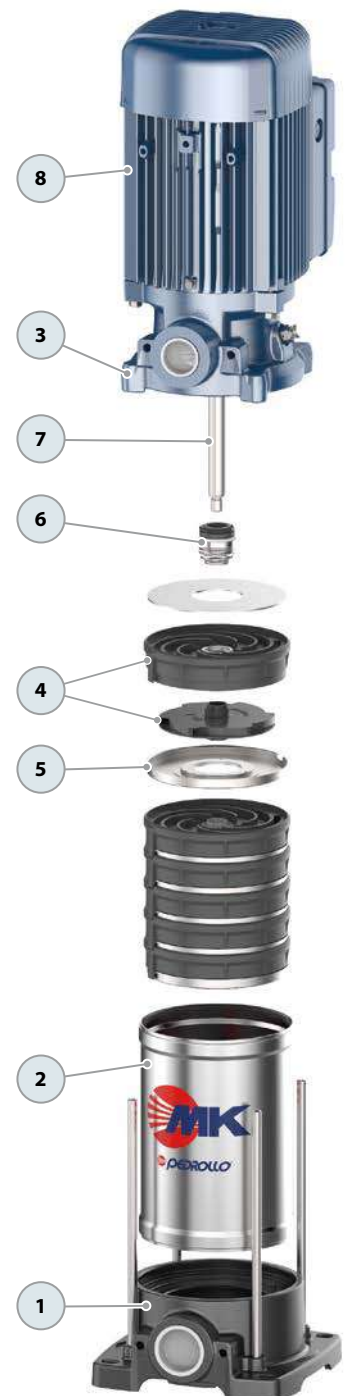

-  Clean water
-  Civil use
-  Agricultural use
-  Industrial use



※ **HT pumps are designed for high hydraulic performance featuring a robust, compact, and reliable mechanical construction..**

- ※ Jacket **Stainless steel AISI 304**
- ※ Impellers: **Stainless steel AISI 304**
- ※ Diffusers: **Stainless steel AISI 304**
- ※ Shaft **Stainless steel AISI 431**

PERFORMANCE RANGE

- Flow rate up to **800 l/min** (48 m³/h)
- Head up to **160 m**

INSTALLATION AND USE

Designed to transfer clean water free from abrasive particles and liquids that will not damage the pump's components. Their high efficiency and adaptability to a wide variety of applications make them an ideal choice in the domestic, civil, agricultural, and industrial sectors, particularly for water distribution along pressure tanks to increase overall network pressure. Suggested uses include fire-fighting systems, heavy-duty cleaning applications, industrial power washers, and irrigation.

KEY FEATURES

- ※ **Stainless steel components** extend service life and enhance efficiency.
- ※ Multi-stage design results in exceptionally quiet operation

ELECTRIC MOTOR

The three-phase pumps are equipped with newly developed electric motors designed to work with inverters, which guarantee stable and quiet operation.

Efficiency class **IE3** for three-phase motors and **IE2** for single-phase motors, with class F insulation and IPX4 protection.

APPLICATION LIMITS

- Manometric suction head up to **7 m**
- Liquid temperature between **-15 °C** and **+90 °C**
- Ambient temperature up to **+40 °C**
- Maximum working pressure **16 bar**

AVAILABLE UPON REQUEST

- ※ Handling of liquids with higher or lower temperatures.
- ※ Pump body with NPT threaded ports ANSI B 1.20.1
- ※ COUNTER-FLANGE
- ※ Pump protection kit to prevent dry running
- ※ O-rings in EPDM or VITON (standard version in NBR)
- ※ Different voltage requirements 60 Hz frequency

CURVES AND PERFORMANCE DATA – HS=0 m

50 Hz

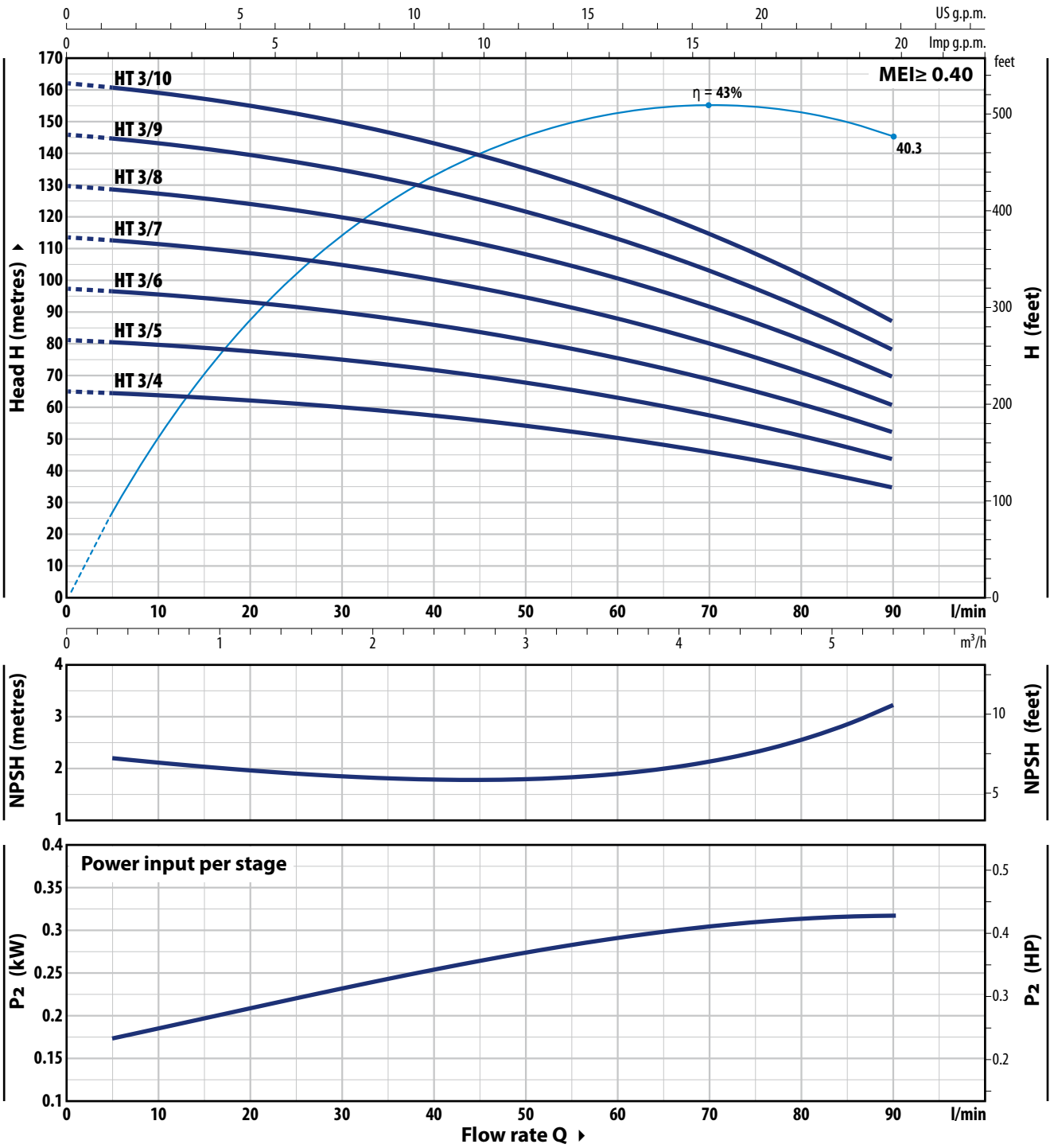

TYPE		POWER (P ₂)		1~3~	Q	H metres									
Single-phase	Three-phase	kW	HP			0	0.3	0.6	1.2	2.4	3.6	4.8	5.4		
					0	5	10	20	40	60	80	90			
	HTm 3/4	0.75	1	IE2 IE3	65	65	63.5	62	57	50	40.5	35			
	HTm 3/5	1.1	1.5		81	80	79	77	71	62.5	51	44			
	HTm 3/6	1.5	2		97	96	95	93	86	75	61	52			
	HTm 3/7	1.8	2.5		113	112	111	108	100	88	71	61			
※	–	2.2	3		129	128	127	124	114	100	81	69.5			
※	–	3	4		146	144	143	139	129	113	91	78			
※	–	3	4		–	160	159	155	143	125	102	87			

Q = Flow rate H = Total manometric head HS = Suction height

Performance curves comply with EN ISO 9906 Grade 3B tolerance limits.

HT 5

CURVES AND PERFORMANCE DATA – HS=0 m

50 Hz

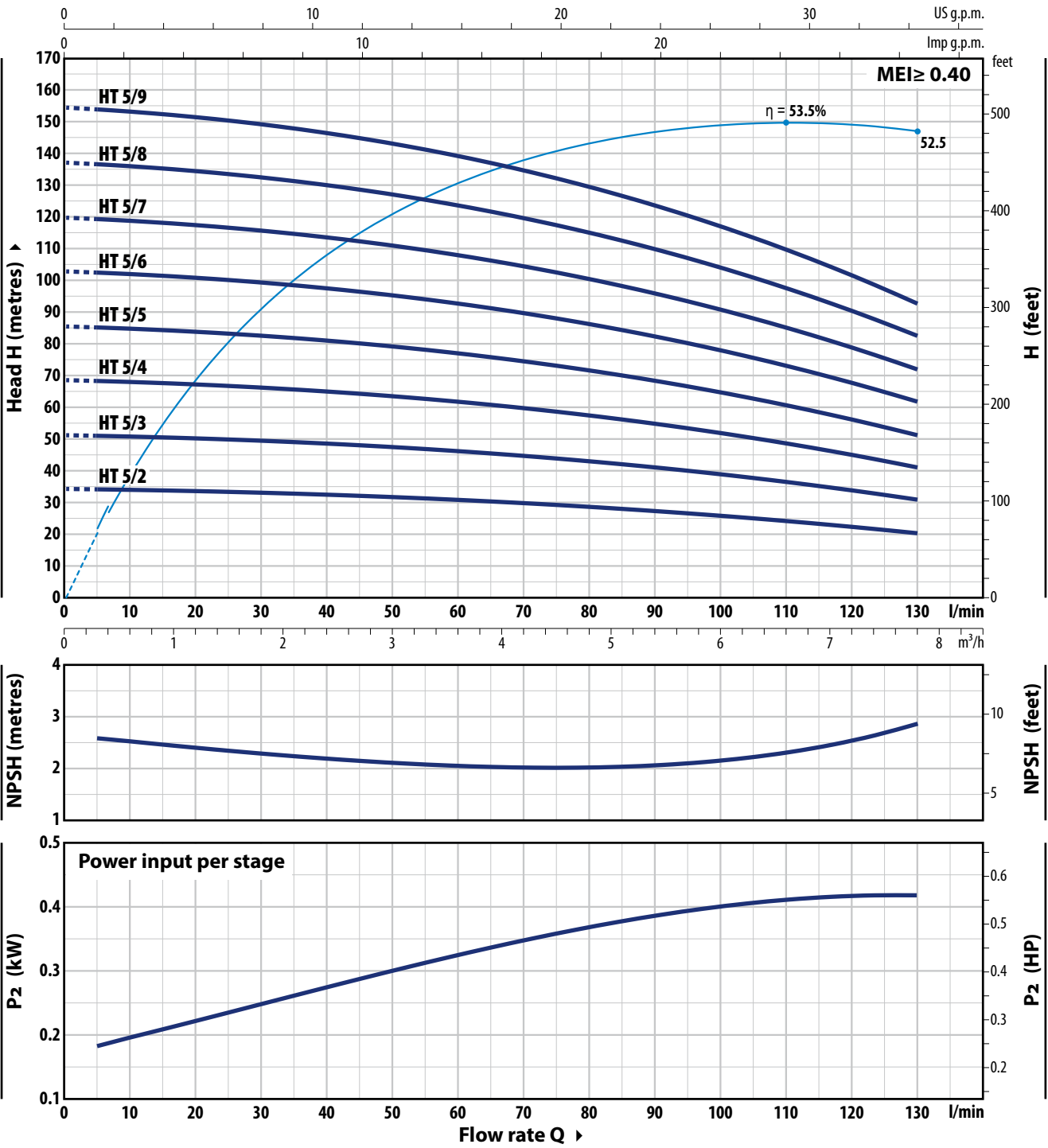

TYPE		POWER (P ₂)		1~3~	Q	Flow rate												
Single-phase	Three-phase	kW	HP			m³/h	0	0.3	0.6	1.2	2.4	3.6	4.8	5.4	6	7.8		
					l/min	0	5	10	20	40	60	80	90	100	130			
HTm 5/2	HT 5/2	0.75	1	IE2 IE3	H metres	35	35	32.7	32.3	32.5	31	25.5	27.5	26	20.5			
HTm 5/3	HT 5/3	1.1	1.5			51.5	51.5	51	50.5	49	46.5	43	41	39	31			
HTm 5/4	HT 5/4	1.5	2			68.5	68.5	68	67	65	62	57.5	55	52	41			
HTm 5/5	HT 5/5	1.8	2.5			86	85	85	84	81	77	72	68.5	65	51.5			
HTm 5/6	HT 5/6	2.2	3			103	103	102	101	98	93	86	82	78	62			
※ -	HT 5/7	3	4			120	120	119	118	114	108	101	96	91	72			
※ -	HT 5/8	3	4			137	137	136	134	130	124	115	110	104	82			
※ -	HT 5/9	4	5.5			154	154	153	151	146	139	129	124	117	93			

Q = Flow rate H = Total manometric head HS = Suction height

Performance curves comply with EN ISO 9906 Grade 3B tolerance limits.

CURVES AND PERFORMANCE DATA – HS=0 m

50 Hz

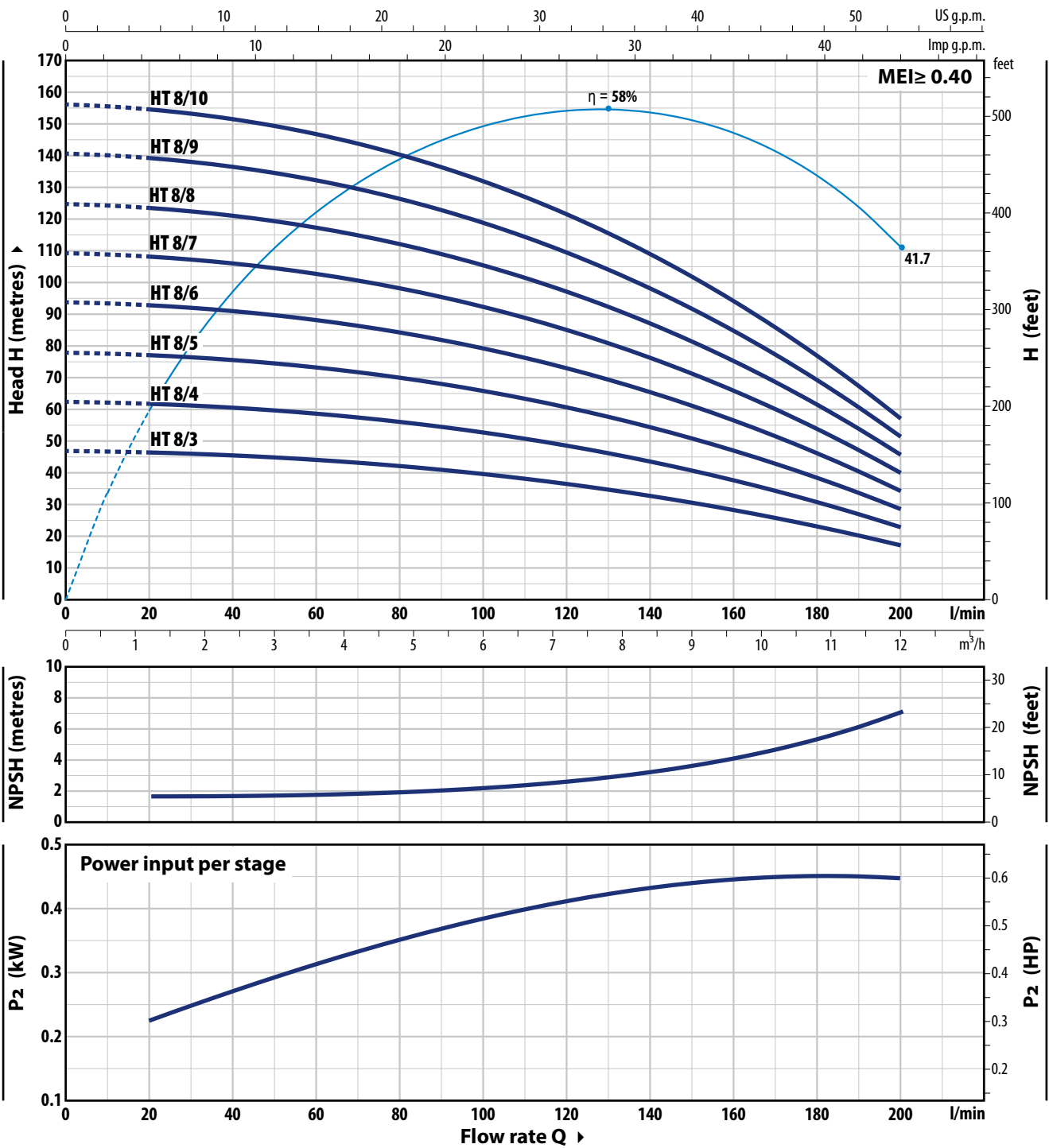

TYPE		POWER (P ₂)		1~3~	Q	m ³ /h																					
Single-phase	Three-phase	kW	HP			0	1.2	2.4	3.6	4.8	6.0	7.2	8.4	9.6	10.8	12.0	0	20	40	60	80	100	120	140	160	180	200
HTm 8/3	HT 8/3	1.1	1.5	IE2 IE3	H metres	47	46.5	45.5	44	42	39.5	36.5	32.5	28	23.1	17	62.5	62	60.5	58.5	56	53	48.5	43.5	37.5	31	23
HTm 8/4	HT 8/4	1.5	2			78	77.5	76	73	70	66	61	54.5	47	38.5	28.5	78	77.5	76	73	70	66	61	54.5	47	38.5	28.5
HTm 8/5	HT 8/5	1.8	2.5			94	93	91	88	84	79	73	65.5	56.5	46	34.5	94	93	91	88	84	79	73	65.5	56.5	46	34.5
HTm 8/6	HT 8/6	2.2	3			109	108	106	103	98	92	85	76	66	54	40	109	108	106	103	98	92	85	76	66	54	40
※ -	HT 8/7	3	4			125	124	121	117	112	106	97	87	75	61.5	45.5	125	124	121	117	112	106	97	87	75	61.5	45.5
※ -	HT 8/8	4	5.5			141	139	136	132	126	119	109	98	85	69	51.5	141	139	136	132	126	119	109	98	85	69	51.5
※ -	HT 8/9	4	5.5			156	155	152	147	140	132	122	109	94	77	57	156	155	152	147	140	132	122	109	94	77	57
※ -	HT 8/10	5.5	7.5																								

Q = Flow rate H = Total manometric head HS = Suction height

Performance curves comply with EN ISO 9906 Grade 3B tolerance limits.

HT 10

CURVES AND PERFORMANCE DATA – HS=0 m

50 Hz

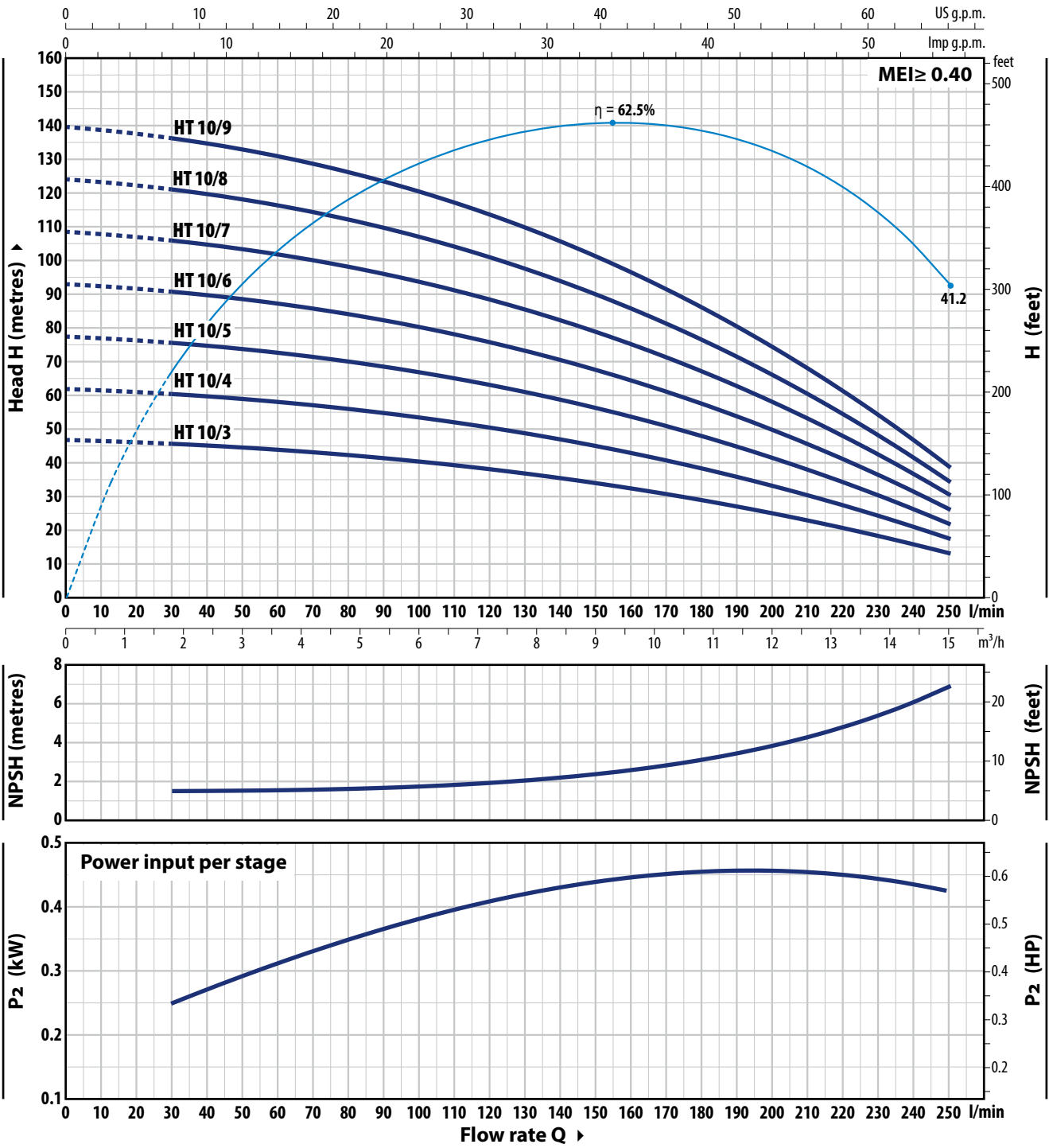

TYPE		POWER (P ₂)		1~3~	Q	Flow rate														
Single-phase	Three-phase	kW	HP			0	1.8	3	3.6	4.8	7.2	9	10.2	12	13.2	15				
HTm 10/3	HT 10/3	1.5	2	IE2 IE3	H metres	0	30	50	60	80	120	150	170	200	220	250				
								47	45.5	44	43.5	42	38	33.5	30.5	24.7	20.3	13		
								62	61	59	58	56	50.5	45	40.5	33	27	18		
								77	75.5	74	73	70	63	56	50.5	41	34	21.5		
								93	91	88	87	84	76	67.5	61	49.5	40.5	26		
								108	106	103	102	98	88	79	71	57.5	47.5	30		
								124	121	118	116	112	101	90	81	66	54.5	34.5		
								139	136	133	131	126	113	101	91	74	61	38.5		

Q = Flow rate H = Total manometric head HS = Suction height

Performance curves comply with EN ISO 9906 Grade 3B tolerance limits.

CURVES AND PERFORMANCE DATA – HS=0 m

50 Hz

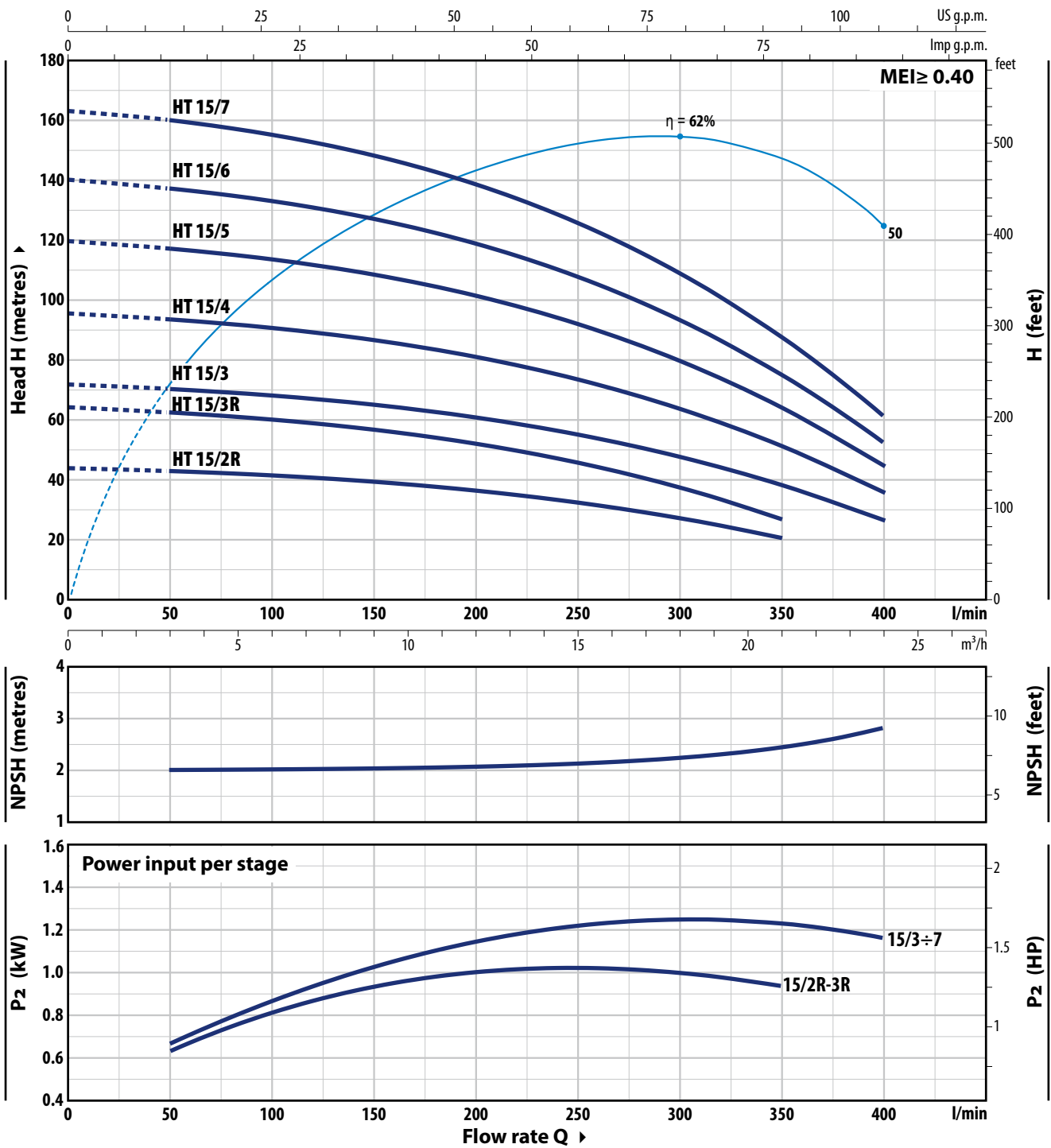

TYPE	POWER (P ₂)		3~	Q	Flow rate Q						
	kW	HP			0	3	6	12	18	21	24
Three-phase					0	50	100	200	300	350	400
HT 15/2R	2.2	3	IE3	H metres	44	43	41.5	36.5	27.5	20.5	
HT 15/3R	3	4			64.5	62.5	60.5	52.0	37.5	27	
HT 15/3	4	5.5			72	70	68.5	61	48	38.5	27
HT 15/4	5.5	7.5			96	94	91	81	64	51.5	36
HT 15/5	7.5	10			120	117	114	102	80	64.5	45
HT 15/6	9.2	12.5			140	137	133	119	94	75.5	52.5
HT 15/7	9.2	12.5			–	160	155	139	109	88	61.5

Q = Flow rate H = Total manometric head HS = Suction height

Performance curves comply with EN ISO 9906 Grade 3B tolerance limits.

HT 30

CURVES AND PERFORMANCE DATA – HS=0 m

50 Hz

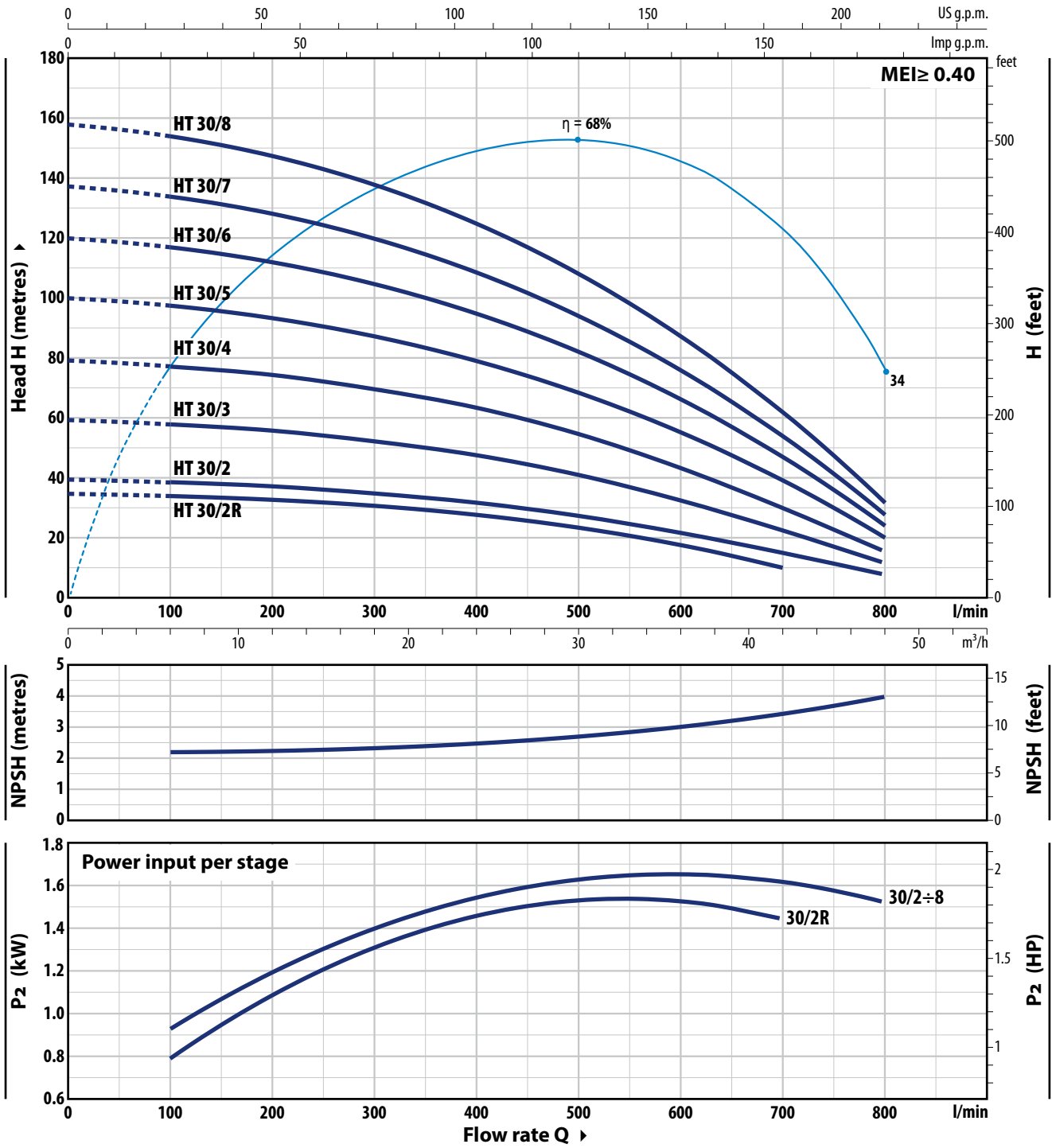

TYPE	POWER (P ₂)		3~	Q	H metres												
	kW	HP			0	6	12	18	24	36	42	48					
Three-phase					0	100	200	300	400	600	700	800					
HT 30/2R	3	4	IE3	H metres	35	34	33	31	28	17.6	10						
HT 30/2	4	5.5			40	39	37.5	35	31.5	22	15.7	8					
HT 30/3	5.5	7.5			60	58.5	56	52.5	47.5	33	23.5	12					
HT 30/4	7.5	10			80	78	75	70	63	44	31.3	16					
HT 30/5	9.2	12.5			100	98	93	87	79	55	39	20					
HT 30/6	11	15			120	117	112	105	95	66.5	47	24					
HT 30/7	15	20			137	134	128	120	108	76	53.5	27.5					
HT 30/8	15	20			158	154	147	138	125	87	62	31.5					

Q = Flow rate H = Total manometric head HS = Suction height

Performance curves comply with EN ISO 9906 Grade 3B tolerance limits.

ABSORPTION

TYPE	VOLTAGE
Single-ph.	230 V
HTm 3/4	7.5 A
HTm 3/5	9.0 A
HTm 3/6	10.5 A
HTm 3/7	12.5 A
HTm 5/2	6.1 A
HTm 5/3	8.5 A
HTm 5/4	10.3 A
HTm 5/5	12.5 A
HTm 5/6	13.5 A
HTm 8/3	8.7 A
HTm 8/4	10.5 A
HTm 8/5	12.5 A
HTm 8/6	14.0 A
HTm 10/3	9.5 A
HTm 10/4	11.0 A
HTm 10/5	13.5 A

TYPE	VOLTAGE			
	230 V - Δ	400 V - 人	400 V - Δ	690 V - 人
HT 3/4	5.2 A	3.0 A	-	-
HT 3/5	6.1 A	3.5 A	-	-
HT 3/6	6.9 A	4.0 A	-	-
HT 3/7	8.3 A	4.8 A	-	-
HT 3/8	11.2 A	6.5 A	-	-
HT 3/9	11.8 A	6.8 A	-	-
HT 3/10	12.1 A	7.0 A	-	-
HT 5/2	4.9 A	2.8 A	-	-
HT 5/3	5.5 A	3.2 A	-	-
HT 5/4	6.6 A	3.8 A	-	-
HT 5/5	8.3 A	4.8 A	-	-
HT 5/6	9.0 A	5.2 A	-	-
HT 5/7	11.8 A	6.8 A	-	-
HT 5/8	13.0 A	7.5 A	-	-
HT 5/9	14.7 A	8.5 A	-	-
HT 8/3	5.7 A	3.3 A	-	-
HT 8/4	6.9 A	4.0 A	-	-
HT 8/5	8.3 A	4.8 A	-	-
HT 8/6	9.3 A	5.4 A	-	-
HT 8/7	12.1 A	7.0 A	-	-
HT 8/8	14.7 A	8.5 A	-	-
HT 8/9	16.4 A	9.5 A	-	-
HT 8/10	-	-	10.5 A	6.1 A
HT 10/3	5.9 A	3.4 A	-	-
HT 10/4	7.8 A	4.5 A	-	-
HT 10/5	9.0 A	5.2 A	-	-
HT 10/6	11.2 A	6.5 A	-	-
HT 10/7	12.5 A	7.2 A	-	-
HT 10/8	14.4 A	8.3 A	-	-
HT 10/9	15.6 A	9.0 A	-	-
HT 15/2R	10.4 A	6.0 A	-	-
HT 15/3R	12.5 A	7.2 A	-	-
HT 15/3	15.2 A	8.8 A	-	-
HT 15/4	-	-	11.2 A	6.5 A
HT 15/5	-	-	14.2 A	8.2 A
HT 15/6	-	-	15.0 A	8.7 A
HT 15/7	-	-	16.5 A	9.5 A
HT 30/2R	12.1 A	7.0 A	-	-
HT 30/2	15.2 A	8.8 A	-	-
HT 30/3	-	-	11.2 A	6.5 A
HT 30/4	-	-	14.1 A	8.2 A
HT 30/5	-	-	16.5 A	9.5 A
HT 30/6	-	-	19.0 A	11.0 A
HT 30/7	-	-	22.0 A	12.7 A
HT 30/8	-	-	24.5 A	14.2 A

PALLET CAPACITY

TYPE		NO. OF PUMPS
Single-phase	Three-phase	
HTm 3/4	HT 3/4	12
HTm 3/5	HT 3/5	12
HTm 3/6	HT 3/6	12
HTm 3/7	HT 3/7	12
HTm 3/8	HT 3/8	4
-	HT 3/9	4
-	HT 3/10	4
HTm 5/2	HT 5/2	12
HTm 5/3	HT 5/3	12
HTm 5/4	HT 5/4	12
HTm 5/5	HT 5/5	12
HTm 5/6	HT 5/6	12
-	HT 5/7	4
-	HT 5/8	4
-	HT 5/9	4
HTm 8/3	HT 8/3	12
HTm 8/4	HT 8/4	12
HTm 8/5	HT 8/5	12
HTm 8/6	HT 8/6	12
-	HT 8/7	4
-	HT 8/8	4
-	HT 8/9	4
-	HT 8/10	4
HTm 10/3	HT 10/3	12
HTm 10/4	HT 10/4	12
HTm 10/5	HT 10/5	12
-	HT 10/6	12
-	HT 10/7	4
-	HT 10/8	4
-	HT 10/9	4
-	HT 15/2R	4
-	HT 15/3R	4
-	HT 15/3	4
-	HT 15/4	4
-	HT 15/5	4
-	HT 15/6	2
-	HT 15/7	2
-	HT 30/2R	4
-	HT 30/2	4
-	HT 30/3	4
-	HT 30/4	4
-	HT 30/5	2
-	HT 30/6	2
-	HT 30/7	2
-	HT 30/8	2

DIMENSIONS AND WEIGHT

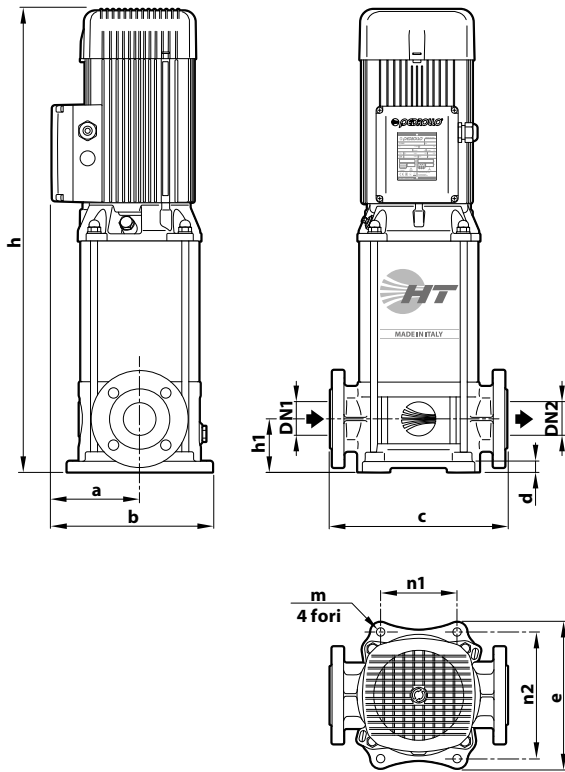

FLANGE

TYPE	DN mm	F mm	D mm	K mm	HOLES	
					N°	Ø mm
HT 3	25	1"	115	85	4	14
HT 5	32	1¼"	140	100		18
HT 8	40	1½"	150	110		18
HT 10	40	1½"	150	110		18
HT 15	50	2"	165	125		18
HT 30	65	2½"	185	145	8	

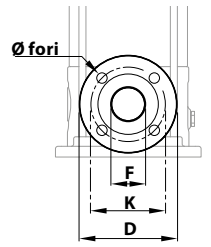

COUNTER-FLANGE

TYPE	DN mm	F mm	D mm	K mm	HOLES	
					N°	Ø mm
HT 3	25	1"	115	85	4	14
HT 5	32	1¼"	140	100		18
HT 8	40	1½"	150	110		18
HT 10	40	1½"	150	110		18
HT 15	50	2"	165	125		18
HT 30	65	2½"	185	145	8	

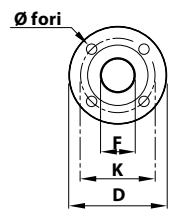

TYPE		PORTS		N° STAGES	DIMENSIONS mm										kg											
Single-ph.	Three-ph.	DN1	DN2		a	b	c	d	e	h	h1	n1	n2	m	1~	3~										
HTm 3/4	HT 3/4	1"	1"	4	126	231	250	15	210	75	100	180	Ø 13	33.5	33.5											
HTm 3/5	HT 3/5			5										33.7	33.7											
HTm 3/6	HT 3/6			6										35.0	35.0											
HTm 3/7	HT 3/7			7										39.9	39.9											
-	HT 3/8			8										-	47.2											
-	HT 3/9			9										-	48.2											
-	HT 3/10			10										-	49.1											
HTm 5/2	HT 5/2			2										1¼"	1¼"	126	231	250	15	210	75	100	180	Ø 13	33.0	33.0
HTm 5/3	HT 5/3			3																					33.2	33.2
HTm 5/4	HT 5/4			4																					35.2	35.2
HTm 5/5	HT 5/5	5	37.5	37.5																						
HTm 5/6	HT 5/6	6	38.5	38.5																						
-	HT 5/7	7	-	47.3																						
-	HT 5/8	8	-	48.3																						
-	HT 5/9	9	-	52.5																						
HTm 8/3	HT 8/3	3	1½"	1½"	126	231	280	15	210	80	100	180	Ø 13												34.6	34.6
HTm 8/4	HT 8/4	4																							36.6	36.6
HTm 8/5	HT 8/5	5												40.1	40.1											
HTm 8/6	HT 8/6	6												40.9	40.9											
-	HT 8/7	7												-	48.6											
-	HT 8/8	8												-	52.7											
-	HT 8/9	9												-	53.7											
-	HT 8/10	10												-	58.7											
HTm 10/3	HT 10/3	3												1½"	1½"	126	231	280	15	210	80	100	180	Ø 13	34.7	34.7
HTm 10/4	HT 10/4	4																							36.7	36.7
HTm 10/5	HT 10/5	5	40.2	40.2																						
-	HT 10/6	6	-	48.5																						
-	HT 10/7	7	-	48.7																						
-	HT 10/8	8	-	52.8																						
-	HT 10/9	9	-	53.8																						
-	HT 15/2R	2	2"	2"	151	275	300	18	247	90	130	215	Ø 14												-	53.0
-	HT 15/3R	3																							-	53.5
-	HT 15/3	3																							-	58.0
-	HT 15/4	4												-	64.0											
-	HT 15/5	5												-	72.0											
-	HT 15/6	6												-	116.5											
-	HT 15/7	7												-	117.0											
-	HT 30/2R	2												2½"	2½"	151	275	320	18	247	105	130	215	Ø 14	-	55.0
-	HT 30/2	2																							-	58.0
-	HT 30/3	3																							-	63.0
-	HT 30/4	4	-	71.5																						
-	HT 30/5	5	-	125.0																						
-	HT 30/6	6	-	125.5																						
-	HT 30/7	7	-	138.0																						
-	HT 30/8	8	-	138.5																						

MATERIALS AND COMPONENTS

1 Pump body Cast iron JL250 with cataphoresis treatment, fitted with flanged and threaded ISO 228/1 ports

2 Cover Cast iron JL250 with cataphoresis treatment

3 External sleeve Stainless steel **AISI 304**

4 Impellers Stainless steel **AISI 304**

5 Diffusers Stainless steel **AISI 304**

6 Mechanical seal

Water pump	Seal	Shaft	Materials
HT 3 - 5 8 - 10	FN-18	Ø 18 mm	Graphite / Ceramic / NBR
HT 15 - 30	FN-KU-24	Ø 24 mm	Graphite / Ceramic / NBR
	ISO 3069 EN 12756		

7 Shaft Stainless steel **AISI 431**

8 Electric motor

- **HTm**: single-phase 230 V - 50 Hz with capacitor and winding integrated thermal motor protection
- **HT**: three-phase
230/400 V - 50 Hz up to 4 kW
400/690 V - 50 Hz 5.5 to 15 kW

※ Pumps are equipped with high-efficiency motors (IEC 60034-30-1)
class **IE2** for single-phase models
class **IE3** for three-phase models

Continuous running duty **S1**



-  Clean water
-  Civil use
-  Agricultural use
-  Industrial use

※ Pump entirely made of stainless steel



※ HT-PRO pumps are designed for high hydraulic performance combined with a robust, compact and reliable mechanical construction.

- ※ Pump body: **Stainless steel AISI 304**
- ※ Cover: **Stainless steel AISI 304**
- ※ Jacket: **Stainless steel AISI 304**
- ※ Impellers: **Stainless steel AISI 304**
- ※ Diffusers: **Stainless steel AISI 304**
- ※ Shaft: **Stainless steel AISI 431**

PERFORMANCE RANGE

- Flow rate up to **800 l/min** (48 m³/h)
- Head up to **160 m**

INSTALLATION AND USE

Designed to transfer clean water free from abrasive particles and liquids that will not damage the pump's components.

Their high efficiency and adaptability to a wide variety of applications make them an ideal choice in the domestic, civil, agricultural, and industrial sectors, particularly for water distribution along pressure tanks to increase overall network pressure. Suggested uses include fire-fighting systems, heavy-duty cleaning applications, industrial power washers, and irrigation.

KEY FEATURES

- ※ The multi-stage stainless steel construction guarantees a long service life and a very low noise threshold during operation.
- ※ Stainless steel components extend service life and enhance efficiency.
- ※ Multi-stage design results in exceptionally quiet operation

APPLICATION LIMITS

- Manometric suction head up to **7 m**
- Liquid temperature between **-15 °C** and **+90 °C**
- Ambient temperature up to **+40 °C**
- Maximum working pressure **16 bar**

ELECTRIC MOTOR

The three-phase pumps are equipped with newly developed electric motors designed to work with inverters, which guarantee stable and quiet operation.

Efficiency class **IE3** for three-phase motors and **IE2** for single-phase motors, with class F insulation and IPX4 protection.

AVAILABLE UPON REQUEST

- ※ AISI 316 stainless steel pump
- ※ Handling of liquids with higher or lower temperatures.
- ※ Pump body with NPT threaded ports ANSI B 1.20.1
- ※ Pump protection kit to prevent dry running
- ※ O-rings in EPDM or VITON (standard version in NBR)
- ※ Different voltage requirements 60 Hz frequency

CURVES AND PERFORMANCE DATA – HS=0 m

50 Hz

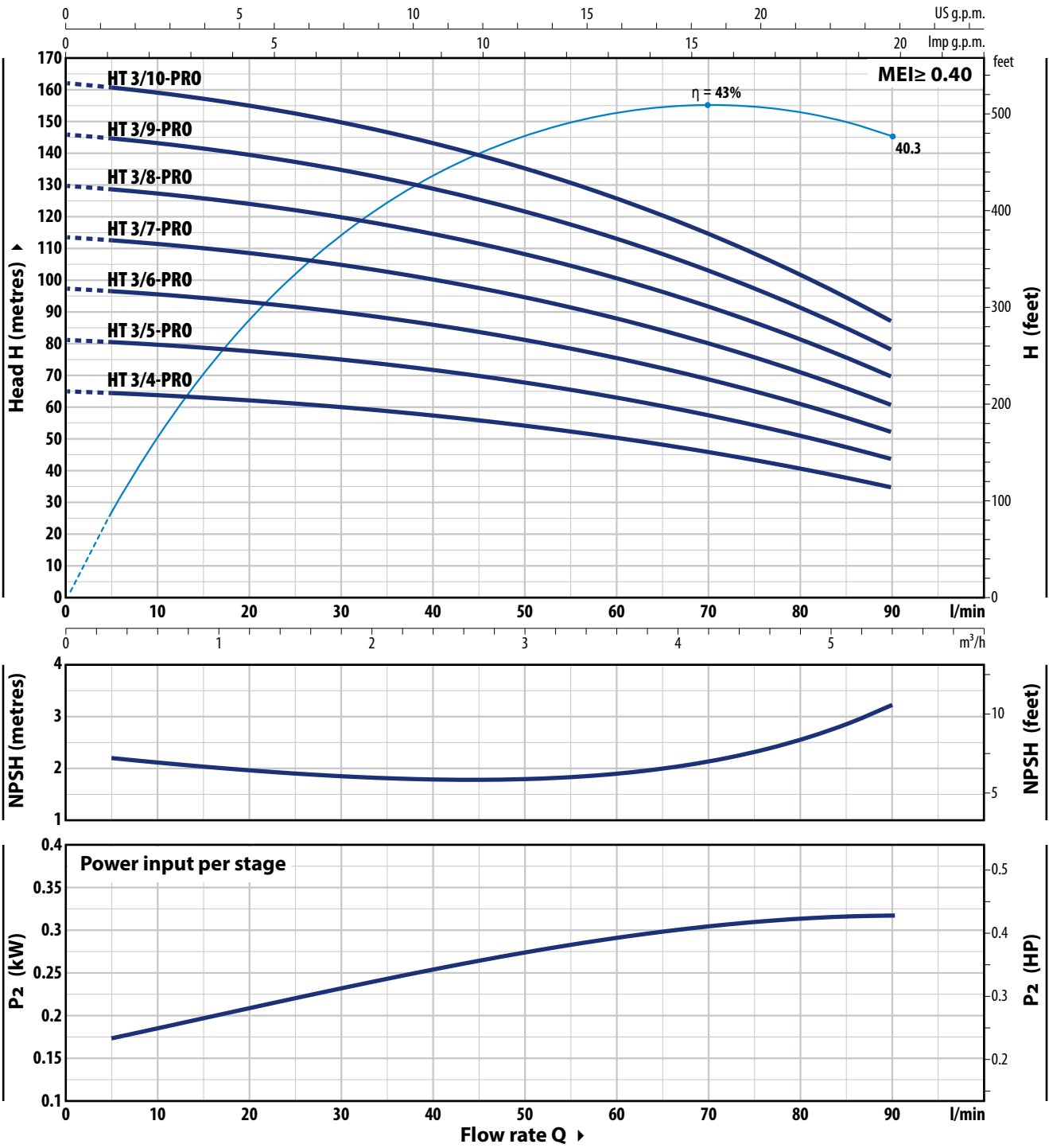

TYPE		POWER (P ₂)		1~3~	Q	Flow rate									
Single-phase	Three-phase	kW	HP			m ³ /h	0	0.3	0.6	1.2	2.4	3.6	4.8	5.4	
					l/min	0	5	10	20	40	60	80	90		
HTm 3/4 - PRO	HT 3/4 - PRO	0.75	1	IE2 IE3	H metres	65	65	63.5	62	57	50	40.5	35		
HTm 3/5 - PRO	HT 3/5 - PRO	1.1	1.5			81	80	79	77	71	62.5	51	44		
HTm 3/6 - PRO	HT 3/6 - PRO	1.5	2			97	96	95	93	86	75	61	52		
HTm 3/7 - PRO	HT 3/7 - PRO	1.8	2.5			113	112	111	108	100	88	71	61		
※ -	HT 3/8 - PRO	2.2	3			129	128	127	124	114	100	81	69.5		
※ -	HT 3/9 - PRO	3	4			146	144	143	139	129	113	91	78		
※ -	HT 3/10 - PRO	3	4			-	160	159	155	143	125	102	87		

Q = Flow rate H = Total manometric head HS = Suction height

Performance curves comply with EN ISO 9906 Grade 3B tolerance limits.

HT 5 - PRO

CURVES AND PERFORMANCE DATA – HS=0 m

50 Hz

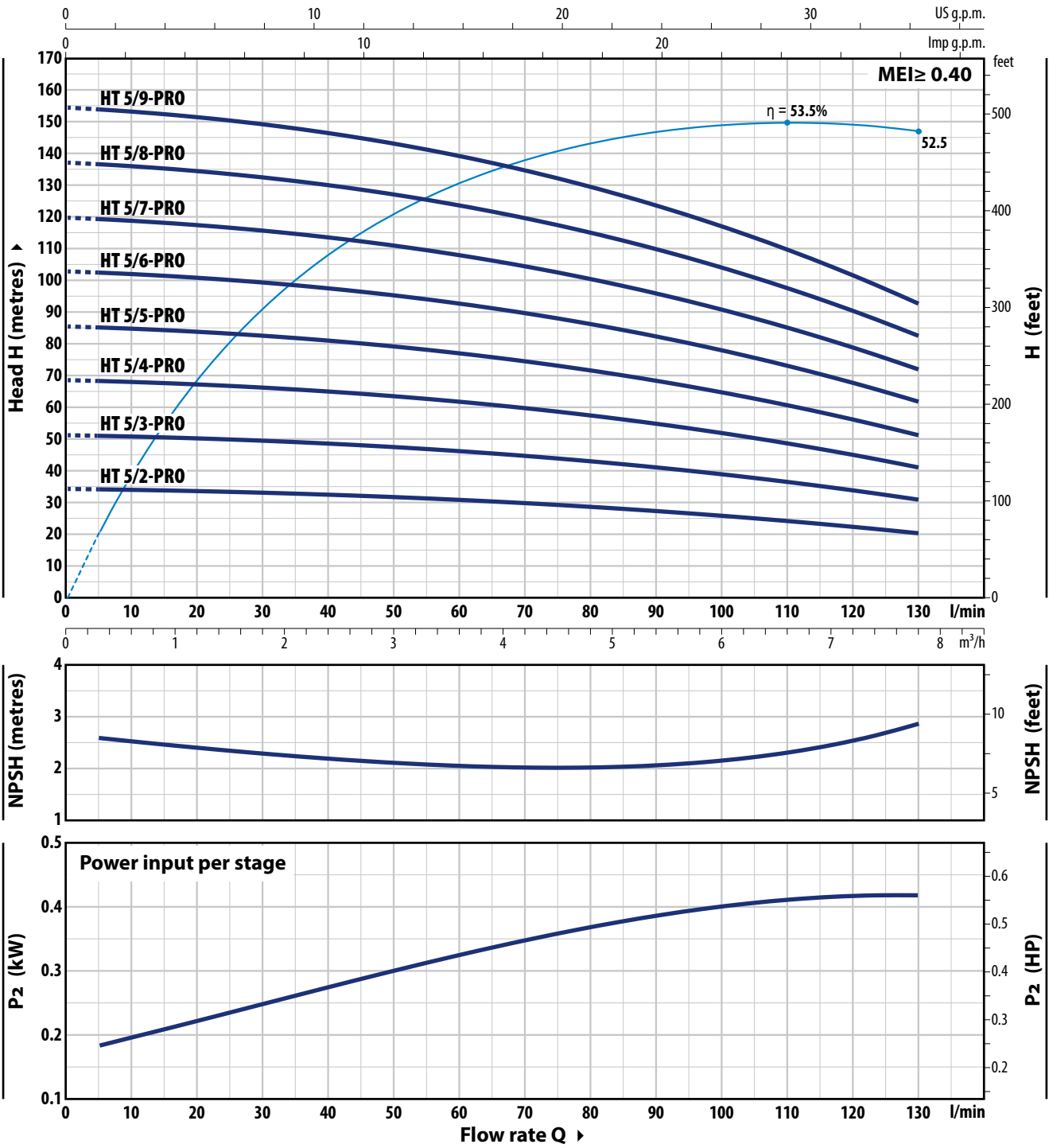

TYPE		POWER (P ₂)		1~3~	Q	m³/h												
Single-phase	Three-phase	kW	HP			0	0.3	0.6	1.2	2.4	3.6	4.8	5.4	6	7.8			
						0	5	10	20	40	60	80	90	100	130			
HTm 5/2 - PRO	HT 5/2 - PRO	0.75	1	IE2 IE3	H metres	35	35	32.7	32.3	32.5	31	25.5	27.5	26	20.5			
HTm 5/3 - PRO	HT 5/3 - PRO	1.1	1.5			51.5	51.5	51	50.5	49	46.5	43	41	39	31			
HTm 5/4 - PRO	HT 5/4 - PRO	1.5	2			68.5	68.5	68	67	65	62	57.5	55	52	41			
HTm 5/5 - PRO	HT 5/5 - PRO	1.8	2.5			86	85	85	84	81	77	72	68.5	65	51.5			
HTm 5/6 - PRO	HT 5/6 - PRO	2.2	3			103	103	102	101	98	93	86	82	78	62			
✘	HT 5/7 - PRO	3	4			120	120	119	118	114	108	101	96	91	72			
✘	HT 5/8 - PRO	3	4			137	137	136	134	130	124	115	110	104	82			
✘	HT 5/9 - PRO	4	5.5			154	154	153	151	146	139	129	124	117	93			

Q = Flow rate H = Total manometric head HS = Suction height

Performance curves comply with EN ISO 9906 Grade 3B tolerance limits.

CURVES AND PERFORMANCE DATA – HS=0 m

50 Hz

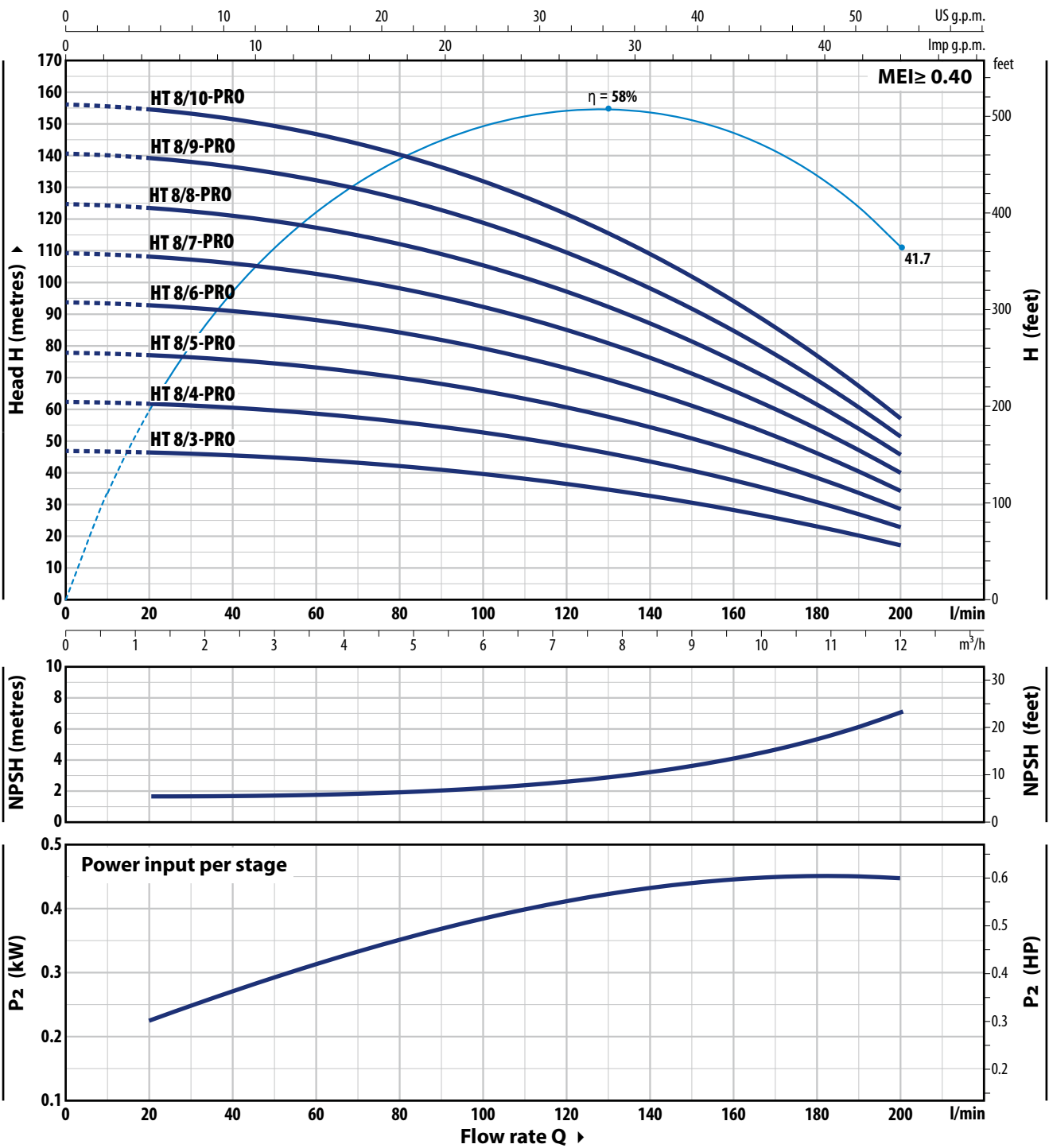

TYPE		POWER (P ₂)		1~3~	Q	H metres																						
Single-phase	Three-phase	kW	HP			0	1.2	2.4	3.6	4.8	6.0	7.2	8.4	9.6	10.8	12.0	0	20	40	60	80	100	120	140	160	180	200	
HTm 8/3 - PRO	HT 8/3 - PRO	1.1	1.5	IE2 IE3	H metres	47	46.5	45.5	44	42	39.5	36.5	32.5	28	23	17	62.5	62	60.5	58.5	56	53	48.5	43.5	37.5	31	23	
HTm 8/4 - PRO	HT 8/4 - PRO	1.5	2			78	77.5	76	73	70	66	61	54.5	47	38.5	28.5	94	93	91	88	84	79	73	65.5	56.5	46	34.5	
HTm 8/5 - PRO	HT 8/5 - PRO	1.8	2.5			109	108	106	103	98	92	85	76	66	54	40	125	124	121	117	112	106	97	87	75	61.5	45.5	
HTm 8/6 - PRO	HT 8/6 - PRO	2.2	3			141	139	136	132	126	119	109	98	85	69	51.5	156	155	152	147	140	132	122	109	94	77	57	
※ -	HT 8/7 - PRO	3	4																									
※ -	HT 8/8 - PRO	4	5.5																									
※ -	HT 8/9 - PRO	4	5.5																									
※ -	HT 8/10 - PRO	5.5	7.5																									

Q = Flow rate H = Total manometric head HS = Suction height

Performance curves comply with EN ISO 9906 Grade 3B tolerance limits.

HT 10 - PRO

CURVES AND PERFORMANCE DATA – HS=0 m

50 Hz

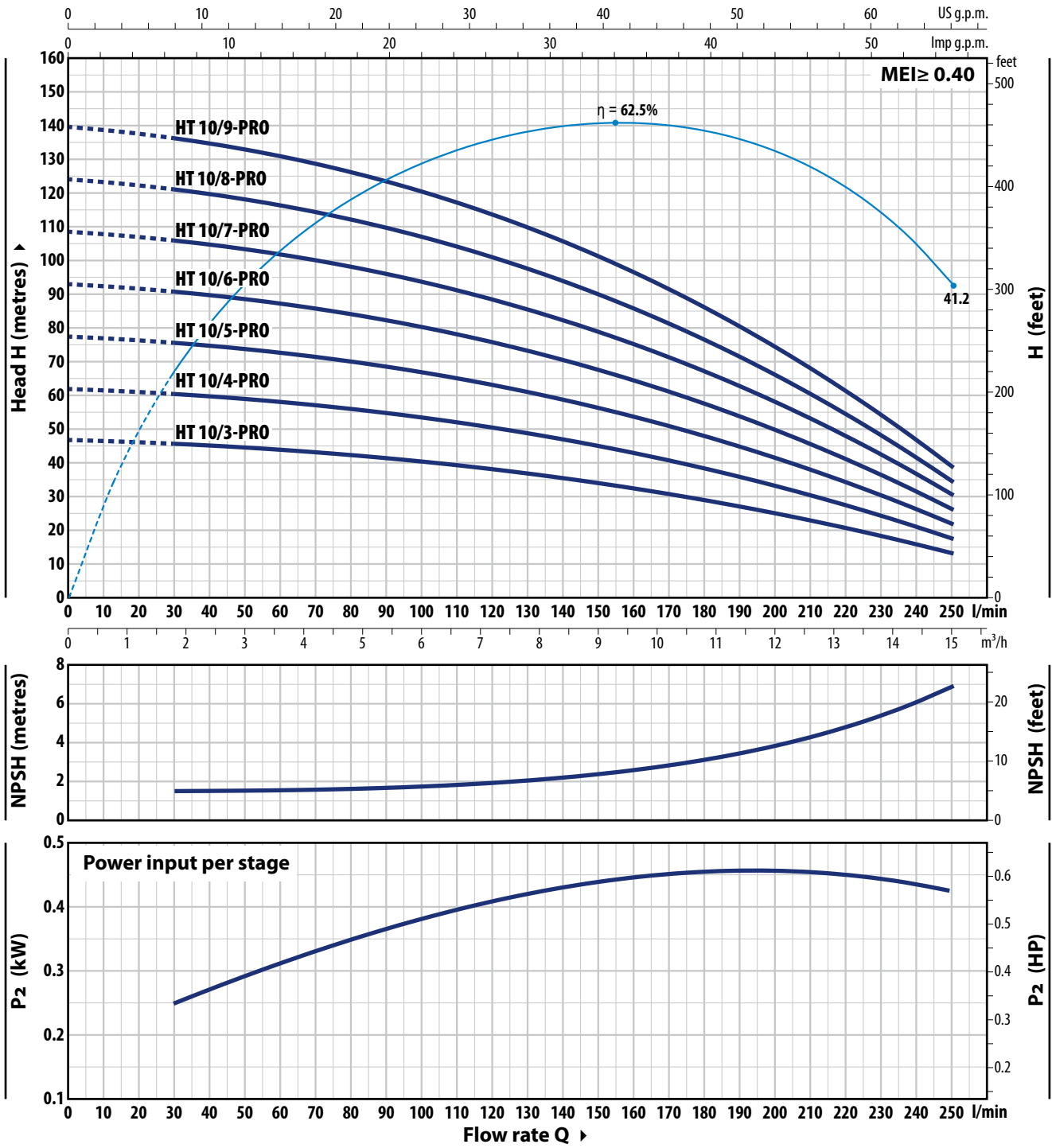

TYPE		POWER (P ₂)		1~3~	Q	Flow rate Q														
Single-phase	Three-phase	kW	HP			m ³ /h	0	1.8	3	3.6	4.8	7.2	9	10.2	12	13.2	15			
					0	30	50	60	80	120	150	170	200	220	250					
HTm 10/3 - PRO	HT 10/3 - PRO	1.5	2	IE2 IE3 H metres	47	45.5	44	43.5	42	38	33.5	30.5	24.7	20.3	13					
HTm 10/4 - PRO	HT 10/4 - PRO	1.8	2.5		62	61	59	58	56	50.5	45	40.5	33	27	18					
HTm 10/5 - PRO	HT 10/5 - PRO	2.2	3		77	75.5	74	73	70	63	56	50.5	41	34	21.5					
-	HT 10/6 - PRO	3	4		93	91	88	87	84	76	67.5	61	49.5	40.5	26					
-	HT 10/7 - PRO	3	4		108	106	103	102	98	88	79	71	57.5	47.5	30					
-	HT 10/8 - PRO	4	5.5		124	121	118	116	112	101	90	81	66	54.5	34.5					
-	HT 10/9 - PRO	4	5.5		139	136	133	131	126	113	101	91	74	61	38.5					

Q = Flow rate H = Total manometric head HS = Suction height

Performance curves comply with EN ISO 9906 Grade 3B tolerance limits.

CURVES AND PERFORMANCE DATA – HS=0 m

50 Hz

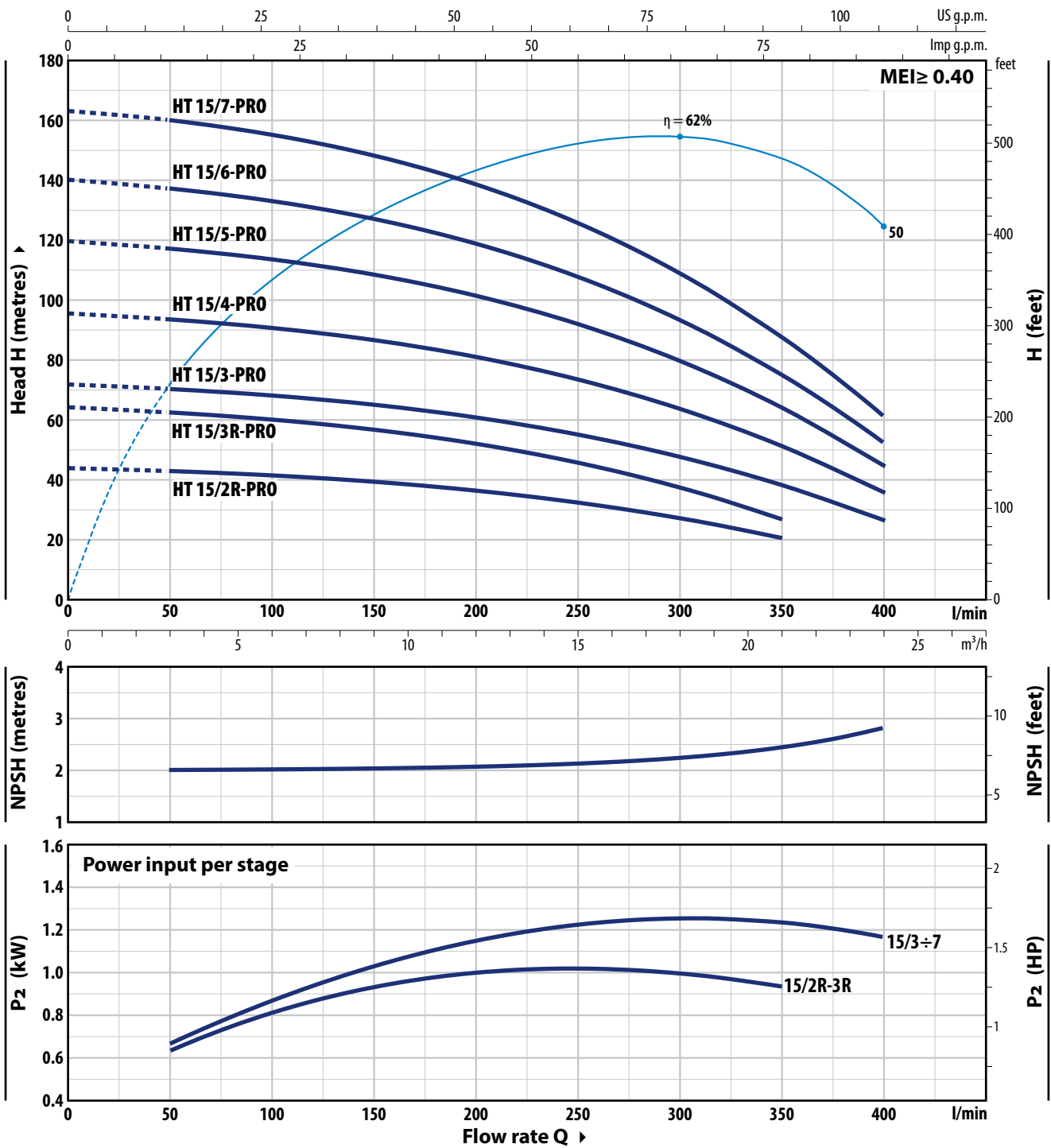

TYPE	POWER (P ₂)		3~	Q	Flow rate						
	kW	HP			0	3	6	12	18	21	24
Three-phase				Q	0	50	100	200	300	350	400
HT 15/2R - PRO	2.2	3	IE3	H metres	44	43	41.5	36.5	27.5	20.5	
HT 15/3R - PRO	3	4			64.5	62.5	60.5	52.0	37.5	27	
HT 15/3 - PRO	4	5.5			72	70	68.5	61	48	38.5	27
HT 15/4 - PRO	5.5	7.5			96	94	91	81	64	51.5	36
HT 15/5 - PRO	7.5	10			120	117	114	102	80	64.5	45
HT 15/6 - PRO	9.2	12.5			140	137	133	119	94	75.5	52.5
HT 15/7 - PRO	9.2	12.5			-	160	155	139	109	88	61.5

Q = Flow rate H = Total manometric head HS = Suction height

Performance curves comply with EN ISO 9906 Grade 3B tolerance limits.

HT 30 - PRO

CURVES AND PERFORMANCE DATA – HS=0 m

50 Hz

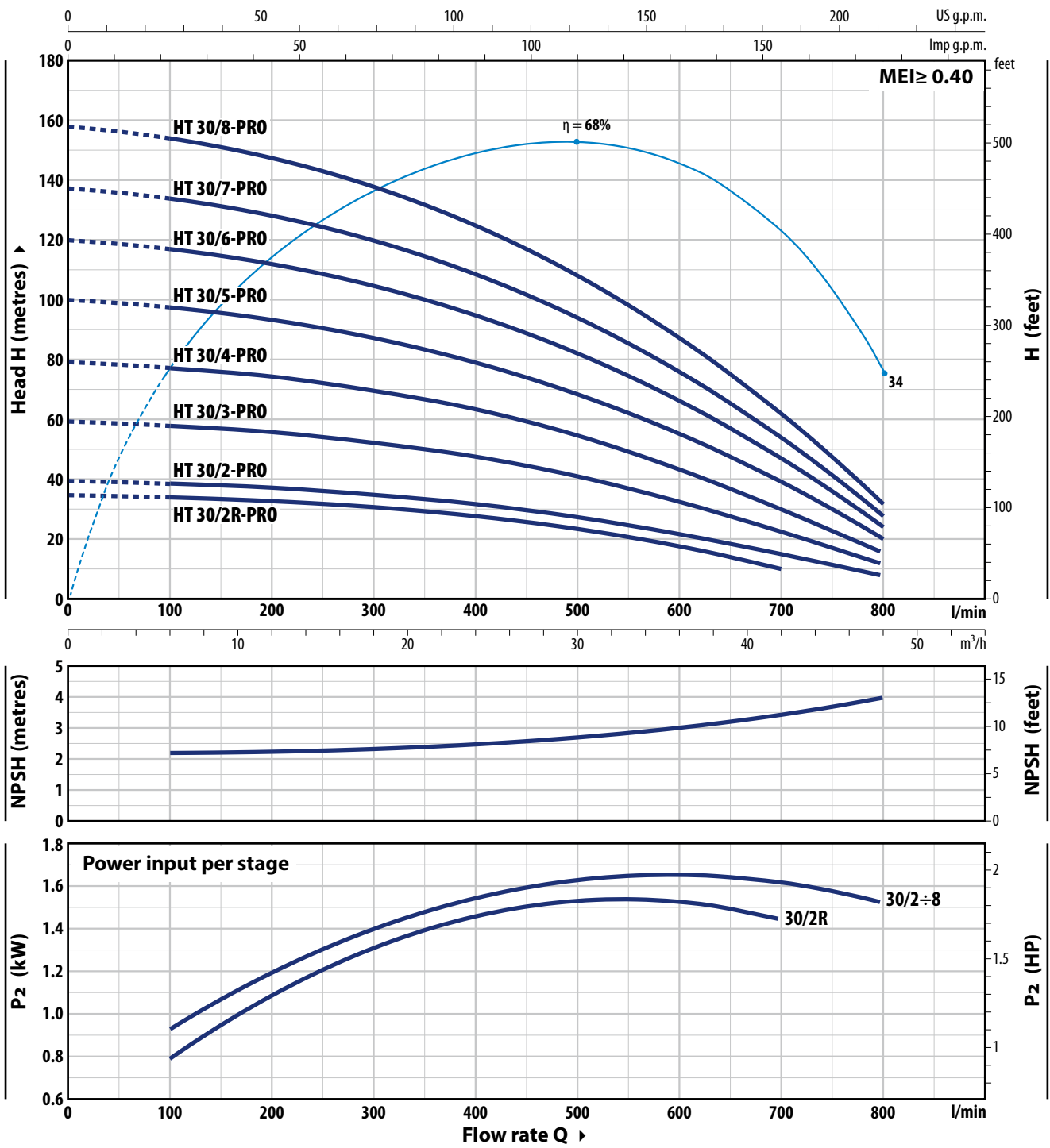

TYPE	POWER (P ₂)		3~	Q	m ³ /h											
	kW	HP			0	6	12	18	24	36	42	48				
Three-phase					0	100	200	300	400	600	700	800				
HT 30/2R - PRO	3	4	IE3	H metres	35	34	33	31	28	17.6	10					
HT 30/2 - PRO	4	5.5			40	39	37.5	35	31.5	22	15.7	8				
HT 30/3 - PRO	5.5	7.5			60	58.5	56	52.5	47.5	33	23.5	12				
HT 30/4 - PRO	7.5	10			80	78	75	70	63	44	31.3	16				
HT 30/5 - PRO	9.2	12.5			100	98	93	87	79	55	39	20				
HT 30/6 - PRO	11	15			120	117	112	105	95	66.5	47	24				
HT 30/7 - PRO	15	20			137	134	128	120	108	76	53.5	27.5				
HT 30/8 - PRO	15	20			158	154	147	138	125	87	62	31.5				

Q = Flow rate H = Total manometric head HS = Suction height

Performance curves comply with EN ISO 9906 Grade 3B tolerance limits.

ABSORPTION

TYPE	VOLTAGE
Single-phase	230 V
HTm 3/4 - PRO	7.5 A
HTm 3/5 - PRO	9.0 A
HTm 3/6 - PRO	10.5 A
HTm 3/7 - PRO	12.5 A
HTm 5/2 - PRO	6.1 A
HTm 5/3 - PRO	8.5 A
HTm 5/4 - PRO	10.3 A
HTm 5/5 - PRO	12.5 A
HTm 5/6 - PRO	13.5 A
HTm 8/3 - PRO	8.7 A
HTm 8/4 - PRO	10.5 A
HTm 8/5 - PRO	12.5 A
HTm 8/6 - PRO	14.0 A
HTm 10/3 - PRO	9.5 A
HTm 10/4 - PRO	11.0 A
HTm 10/5 - PRO	13.5 A

TYPE	VOLTAGE			
	230 V - Δ	400 V - 人	400 V - Δ	690 V - 人
HT 3/4 - PRO	5.2 A	3.0 A	-	-
HT 3/5 - PRO	6.1 A	3.5 A	-	-
HT 3/6 - PRO	6.9 A	4.0 A	-	-
HT 3/7 - PRO	8.3 A	4.8 A	-	-
HT 3/8 - PRO	11.2 A	6.5 A	-	-
HT 3/9 - PRO	11.8 A	6.8 A	-	-
HT 3/10 - PRO	12.1 A	7.0 A	-	-
HT 5/2 - PRO	4.9 A	2.8 A	-	-
HT 5/3 - PRO	5.5 A	3.2 A	-	-
HT 5/4 - PRO	6.6 A	3.8 A	-	-
HT 5/5 - PRO	8.3 A	4.8 A	-	-
HT 5/6 - PRO	9.0 A	5.2 A	-	-
HT 5/7 - PRO	11.8 A	6.8 A	-	-
HT 5/8 - PRO	13.0 A	7.5 A	-	-
HT 5/9 - PRO	14.7 A	8.5 A	-	-
HT 8/3 - PRO	5.7 A	3.3 A	-	-
HT 8/4 - PRO	6.9 A	4.0 A	-	-
HT 8/5 - PRO	8.3 A	4.8 A	-	-
HT 8/6 - PRO	9.3 A	5.4 A	-	-
HT 8/7 - PRO	12.1 A	7.0 A	-	-
HT 8/8 - PRO	14.7 A	8.5 A	-	-
HT 8/9 - PRO	16.4 A	9.5 A	-	-
HT 8/10 - PRO	-	-	10.5 A	6.1 A
HT 10/3 - PRO	5.9 A	3.4 A	-	-
HT 10/4 - PRO	7.8 A	4.5 A	-	-
HT 10/5 - PRO	9.0 A	5.2 A	-	-
HT 10/6 - PRO	11.2 A	6.5 A	-	-
HT 10/7 - PRO	12.5 A	7.2 A	-	-
HT 10/8 - PRO	14.4 A	8.3 A	-	-
HT 10/9 - PRO	15.6 A	9.0 A	-	-
HT 15/2R - PRO	10.4 A	6.0 A	-	-
HT 15/3R - PRO	12.5 A	7.2 A	-	-
HT 15/3 - PRO	15.2 A	8.8 A	-	-
HT 15/4 - PRO	-	-	11.2 A	6.5 A
HT 15/5 - PRO	-	-	14.2 A	8.2 A
HT 15/6 - PRO	-	-	15.0 A	8.7 A
HT 15/7 - PRO	-	-	16.5 A	9.5 A
HT 30/2R - PRO	12.1 A	7.0 A	-	-
HT 30/2 - PRO	15.2 A	8.8 A	-	-
HT 30/3 - PRO	-	-	11.2 A	6.5 A
HT 30/4 - PRO	-	-	14.1 A	8.2 A
HT 30/5 - PRO	-	-	16.5 A	9.5 A
HT 30/6 - PRO	-	-	19.0 A	11.0 A
HT 30/7 - PRO	-	-	22.0 A	12.7 A
HT 30/8 - PRO	-	-	24.5 A	14.2 A

PALLET CAPACITY

TYPE		NO. OF PUMPS
Single-phase	Three-phase	
HTm 3/4 - PRO	HT 3/4 - PRO	12
HTm 3/5 - PRO	HT 3/5 - PRO	12
HTm 3/6 - PRO	HT 3/6 - PRO	12
HTm 3/7 - PRO	HT 3/7 - PRO	12
HTm 3/8 - PRO	HT 3/8 - PRO	4
-	HT 3/9 - PRO	4
-	HT 3/10 - PRO	4
HTm 5/2 - PRO	HT 5/2 - PRO	12
HTm 5/3 - PRO	HT 5/3 - PRO	12
HTm 5/4 - PRO	HT 5/4 - PRO	12
HTm 5/5 - PRO	HT 5/5 - PRO	12
HTm 5/6 - PRO	HT 5/6 - PRO	12
-	HT 5/7 - PRO	4
-	HT 5/8 - PRO	4
-	HT 5/9 - PRO	4
HTm 8/3 - PRO	HT 8/3 - PRO	12
HTm 8/4 - PRO	HT 8/4 - PRO	12
HTm 8/5 - PRO	HT 8/5 - PRO	12
HTm 8/6 - PRO	HT 8/6 - PRO	12
-	HT 8/7 - PRO	4
-	HT 8/8 - PRO	4
-	HT 8/9 - PRO	4
-	HT 8/10 - PRO	4
HTm 10/3 - PRO	HT 10/3 - PRO	12
HTm 10/4 - PRO	HT 10/4 - PRO	12
HTm 10/5 - PRO	HT 10/5 - PRO	12
-	HT 10/6 - PRO	12
-	HT 10/7 - PRO	4
-	HT 10/8 - PRO	4
-	HT 10/9 - PRO	4
-	HT 15/2R - PRO	4
-	HT 15/3R - PRO	4
-	HT 15/3 - PRO	4
-	HT 15/4 - PRO	4
-	HT 15/5 - PRO	4
-	HT 15/6 - PRO	2
-	HT 15/7 - PRO	2
-	HT 30/2R - PRO	4
-	HT 30/2 - PRO	4
-	HT 30/3 - PRO	4
-	HT 30/4 - PRO	4
-	HT 30/5 - PRO	2
-	HT 30/6 - PRO	2
-	HT 30/7 - PRO	2
-	HT 30/8 - PRO	2

DIMENSIONS AND WEIGHT

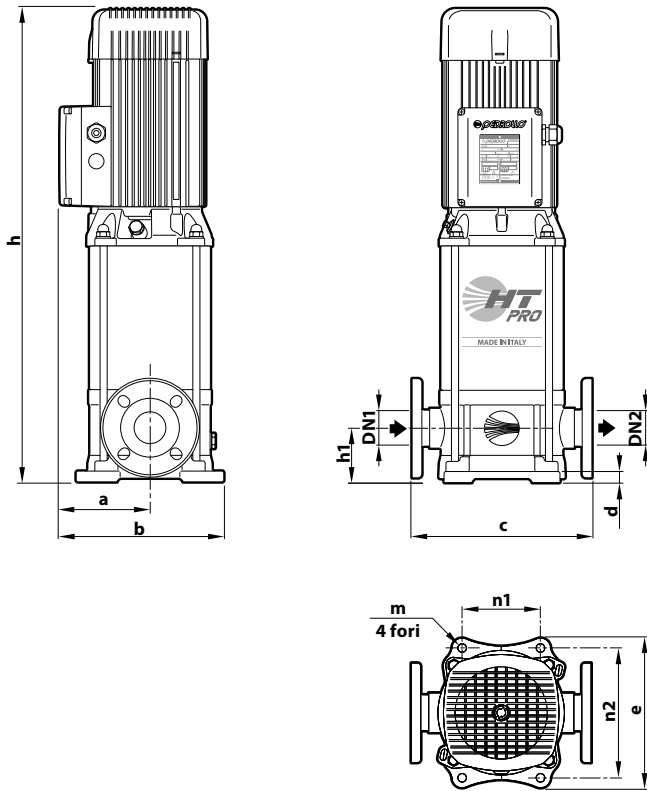

FLANGE

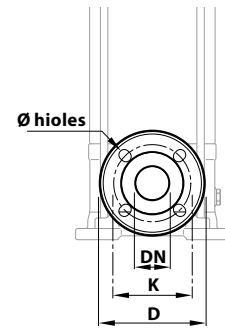

TYPE	DN mm	D mm	K mm	HOLES	
				N°	Ø mm
HT 3 - PRO	25	115	85	4	14
HT 5 - PRO	32	140	100		
HT 8 - PRO	40	150	110		
HT 10 - PRO	40	150	110		
HT 15 - PRO	50	165	125		
HT 30 - PRO	65	185	145		18

TYPE		PORTS		N°	DIMENSIONS mm										kg												
Single-phase	Three-phase	DN1	DN2	STAGES	a	b	c	d	e	h	h1	n1	n2	m	1~	3~											
HTm 3/4 - PRO	HT 3/4 - PRO	1"	1"	4	126	231	250	15	210	509	75	100	180	Ø 13	31.5	31.5											
HTm 3/5 - PRO	HT 3/5 - PRO			5						31.7					31.7												
HTm 3/6 - PRO	HT 3/6 - PRO			6						33.0					33.0												
HTm 3/7 - PRO	HT 3/7 - PRO			7						37.9					37.9												
-	HT 3/8 - PRO			8						-					45.2												
-	HT 3/9 - PRO			9						-					46.2												
-	HT 3/10 - PRO			10						-					47.1												
HTm 5/2 - PRO	HT 5/2 - PRO			2						1 1/4"					1 1/4"	126	231	250	15	210	457	75	100	180	Ø 13	29.9	29.9
HTm 5/3 - PRO	HT 5/3 - PRO			3																	30.1					30.1	
HTm 5/4 - PRO	HT 5/4 - PRO			4																	32.1					32.1	
HTm 5/5 - PRO	HT 5/5 - PRO	5	34.5	34.5																							
HTm 5/6 - PRO	HT 5/6 - PRO	6	35.5	35.5																							
-	HT 5/7 - PRO	7	-	44.3																							
-	HT 5/8 - PRO	8	-	45.3																							
-	HT 5/9 - PRO	9	-	49.5																							
HTm 8/3 - PRO	HT 8/3 - PRO	3	1 1/2"	1 1/2"	126	231	280	15	210		488	80	100	180							Ø 13					30.6	30.6
HTm 8/4 - PRO	HT 8/4 - PRO	4									32.6															32.6	
HTm 8/5 - PRO	HT 8/5 - PRO	5								36.1	36.1																
HTm 8/6 - PRO	HT 8/6 - PRO	6								36.9	36.9																
-	HT 8/7 - PRO	7								-	44.6																
-	HT 8/8 - PRO	8								-	48.7																
-	HT 8/9 - PRO	9								-	49.7																
-	HT 8/10 - PRO	10								-	54.7																
HTm 10/3 - PRO	HT 10/3 - PRO	3								1 1/2"	1 1/2"				126	231	280	15	210	488		80	100	180	Ø 13	30.7	30.7
HTm 10/4 - PRO	HT 10/4 - PRO	4																		32.7						32.7	
HTm 10/5 - PRO	HT 10/5 - PRO	5	36.2	36.2																							
-	HT 10/6 - PRO	6	-	44.5																							
-	HT 10/7 - PRO	7	-	44.7																							
-	HT 10/8 - PRO	8	-	48.8																							
-	HT 10/9 - PRO	9	-	49.8																							
-	HT 15/2R - PRO	2	2"	2"	151	275	300	18	247			589	90	130						215	Ø 14					-	52.0
-	HT 15/3R - PRO	3										-														52.5	
-	HT 15/3 - PRO	3										-														57.0	
-	HT 15/4 - PRO	4								-	63.0																
-	HT 15/5 - PRO	5								-	71.0																
-	HT 15/6 - PRO	6								-	115.5																
-	HT 15/7 - PRO	7								-	116.0																
-	HT 30/2R - PRO	2								2 1/2"	2 1/2"	151			275	320	18	247	604			105	130	215	Ø 14	-	53.5
-	HT 30/2 - PRO	2																	-							56.5	
-	HT 30/3 - PRO	3																	-							61.5	
-	HT 30/4 - PRO	4	-	70.0																							
-	HT 30/5 - PRO	5	-	123.5																							
-	HT 30/6 - PRO	6	-	124.0																							
-	HT 30/7 - PRO	7	-	136.5																							
-	HT 30/8 - PRO	8	-	137.0																							

MATERIALS AND COMPONENTS

1 Pump body Stainless steel **AISI 304**, provided with ISO 228/1 threaded ports

2 Cover Stainless steel **AISI 304**

3 External sleeve Stainless steel **AISI 304**

4 Impellers Stainless steel **AISI 304**

5 Diffusers Stainless steel **AISI 304**

6 Mechanical seal

Water pump	Seal	Shaft	Materials
HT 3 - 5 - 8 - 10 PRO	FN-18	Ø 18 mm	Graphite / Ceramic / NBR
HT 15 - 30 PRO	FN-KU-24	Ø 24 mm	Graphite / Ceramic / NBR
	ISO 3069 EN 12756		

7 Shaft Stainless steel **AISI 316L**

8 Electric motor

- **HTm - PRO**: single-phase 230 V - 50 Hz with capacitor and winding integrated thermal motor protection
- **HT - PRO**: three-phase
230/400 V - 50 Hz up to 4 kW
400/690 V - 50 Hz from 5.5 to 15 kW

※ Pumps are equipped with high-efficiency motors (IEC 60034-30-1)
class **IE2** for single-phase models
class **IE3** for three-phase models

Continuous running duty **S1**



-  Clean water
-  Domestic use
-  Civil use

※ Reduction of energy consumption by up to 50%



From an evolution of the classic JET concept, a SUPER JET was born.

- ※ High hydraulic efficiency
- ※ Better consumption/performance ratio
- ※ Reducing turbulence
- ※ Noise reduction

PERFORMANCE RANGE

- Flow rate up to **120 l/min** (7.2 m³/h)
- Head up to **72 m**

FUTURE JET

Developed by our innovative research and development team, this pump revolutionizes the classic self-priming design.

With an international registered patent, the **FUTURE JET** not only matches the pressure of a traditional JET pump, it surpasses it. Moreover, it doubles the flow rate while reducing energy consumption by up to 50%.

INSTALLATION AND USE

FUTURE JET self-priming pumps are designed to draw water and liquids that contain air.

They are reliable and easy to operate. They are a favorite for domestic use, particularly effective for water distribution with small to medium-sized pressure tanks and suitable for irrigation.

APPLICATION LIMITS

- Manometric suction head up to **9 m** (HS)
- Liquid temperature between **-10 °C** and **+40 °C**
- Ambient temperature up to **+40 °C**
- Maximum working pressure:
 - **6 bar** for FUTURE JET 1
 - **7 bar** for FUTURE JET 2

AVAILABLE UPON REQUEST

- ※ Technopolymer impeller (cost-effective version)
- ※ Different voltage requirements 60 Hz frequency

PATENTS - TRADE MARKS - MODELS

- FUTURE JET® Registered Trade mark No. 018198453
- Registered Community Model No. 002218610
- European Patent No. 1 510 696
- Patent No. PCT/IT2019/050168

CURVES AND PERFORMANCE DATA – HS=0 m

50 Hz

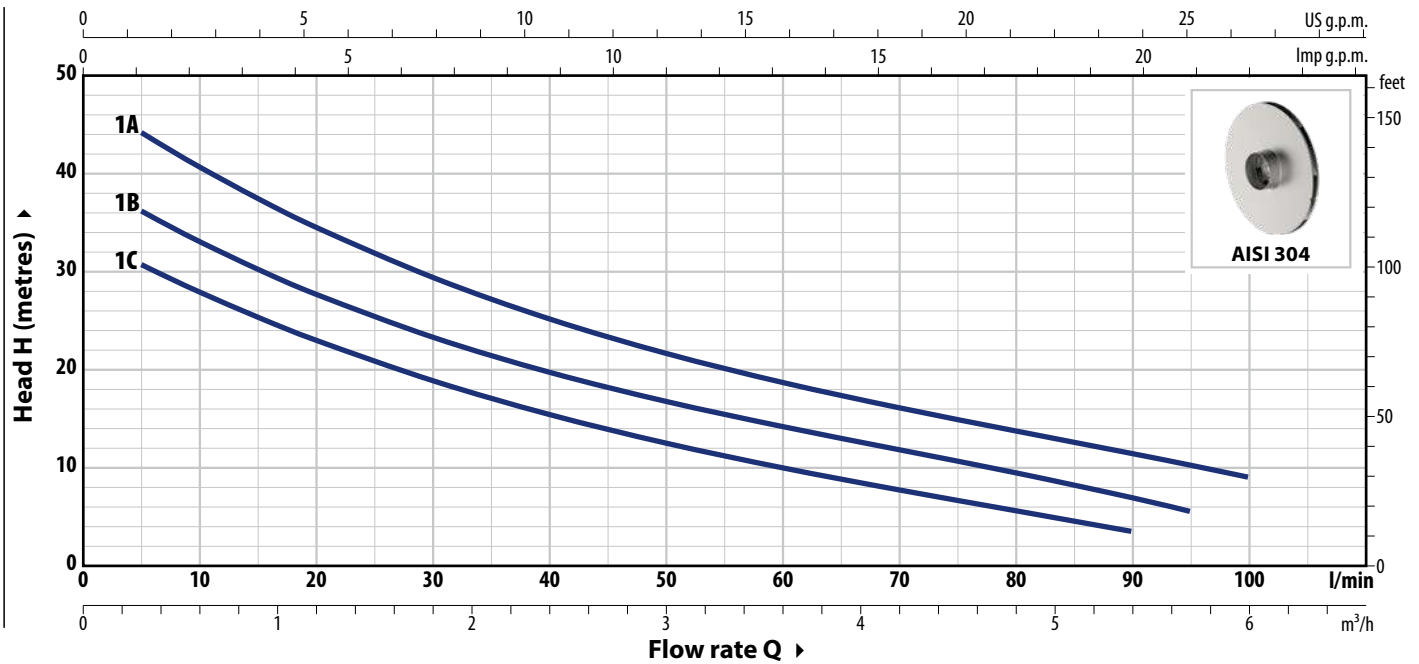

TYPE		POWER (P ₂)		1~	3~	Q	m ³ /h											
Single-phase	Three-phase	kW	HP				0	0.3	0.6	1.2	2.4	3.6	4.8	5.4	5.7	6.0		
FUTURE JETm 1C	FUTURE JET 1C	0.37	0.50				0	5	10	20	40	60	80	90	95	100		
FUTURE JETm 1B	FUTURE JET 1B	0.48	0.65	IE2	IE3	H metres	33.5	30.5	28	23	15.4	10	6	3.5				
FUTURE JETm 1A	FUTURE JET 1A	0.55	0.75				40	36	33	27.6	19.7	14.2	9.5	7	5.5			
							48	44	40.6	34.5	25.2	18.7	13.7	11.4	10.2	9		

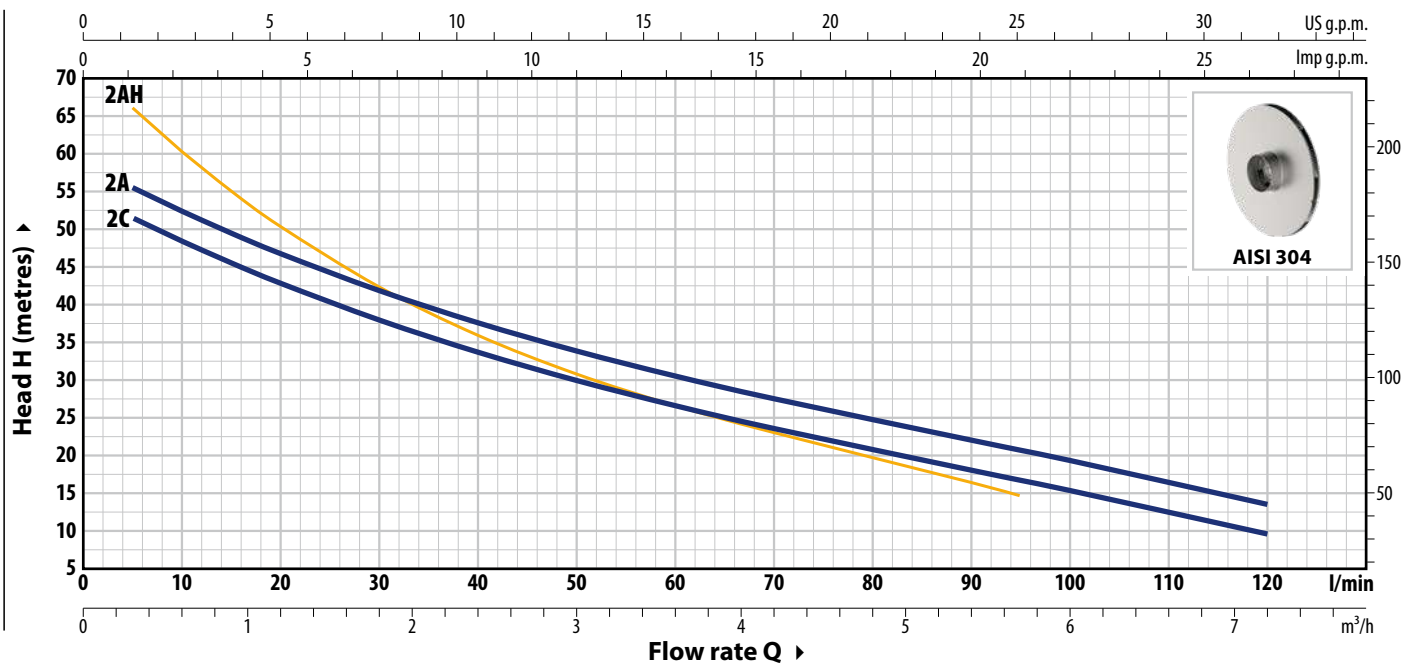

TYPE		POWER (P ₂)		1~	3~	Q	m ³ /h												
Single-phase	Three-phase	kW	HP				0	0.3	0.6	1.2	2.4	3.6	4.8	5.4	5.7	6.0	7.2		
FUTURE JETm 2C	FUTURE JET 2C	0.75	1				55	52	49	43	34	27	20.5	18.3	17	15.5	10		
FUTURE JETm 2A	FUTURE JET 2A	0.90	1.25	IE2	IE3	H metres	59	56	53	47	38	32	25	22.3	21	19.5	13.7		
FUTURE JETm 2AH	FUTURE JET 2AH	0.90	1.25				72	66	60	50.5	36	27	20	16.8	15				

Q = Flow rate H = Total manometric head HS = Suction height

Performance curves comply with EN ISO 9906 Grade 3B tolerance limits.

ABSORPTION

TYPE	VOLTAGE
Single-phase	230 V
FUTURE JETm 1C	2.6 A
FUTURE JETm 1B	3.2 A
FUTURE JETm 1A	4.0 A
FUTURE JETm 2C	5.8 A
FUTURE JETm 2A	6.6 A
FUTURE JETm 2AH	6.6 A

TYPE	VOLTAGE	
	230 V - Δ	400 V - 人
FUTURE JET 1C	1.7 A	1.0 A
FUTURE JET 1B	2.1 A	1.2 A
FUTURE JET 1A	2.8 A	1.6 A
FUTURE JET 2C	4.7 A	2.7 A
FUTURE JET 2A	5.2 A	3.0 A
FUTURE JET 2AH	5.2 A	3.0 A

DIMENSIONS AND WEIGHT

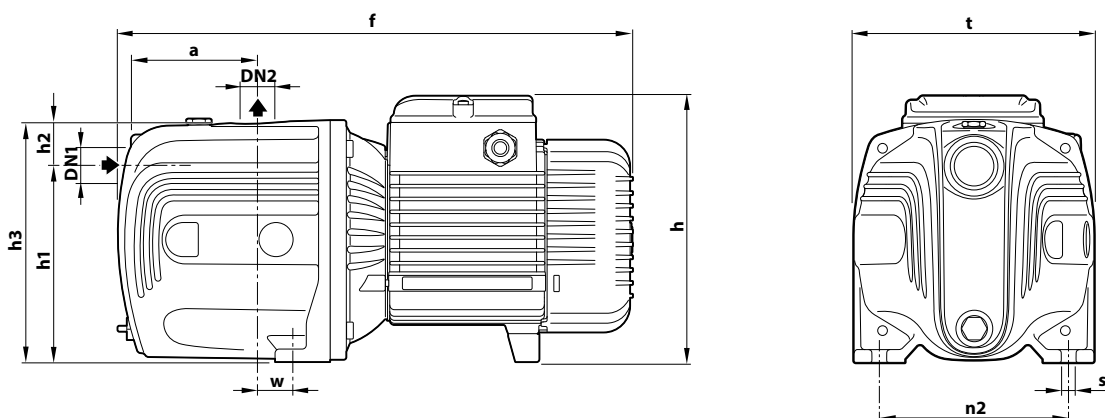

TYPE		PORTS		DIMENSIONS mm										kg	
Single-phase	Three-phase	DN1	DN2	a	f	h	h1	h2	h3	t	n2	w	s	1~	3~
FUTURE JETm 1C	FUTURE JET 1C	1"	1"	94	357	173	127	35	162	158	124	24	10	9.7	9.7
FUTURE JETm 1B	FUTURE JET 1B													9.8	9.8
FUTURE JETm 1A	FUTURE JET 1A													10.7	10.0
FUTURE JETm 2C	FUTURE JET 2C			96	391	201 *	147	33	180	180	142	22	10	14.5	14.5
FUTURE JETm 2A	FUTURE JET 2A													15.5	14.5
FUTURE JETm 2AH	FUTURE JET 2AH													15.5	14.5

(*) h=220 mm for single-phase 110 V versions

PALLET CAPACITY

TYPE		NO. OF PUMPS
Single-phase	Three-phase	
FUTURE JETm 1C	FUTURE JET 1C	98
FUTURE JETm 1B	FUTURE JET 1B	98
FUTURE JETm 1A	FUTURE JET 1A	98
FUTURE JETm 2C	FUTURE JET 2C	72
FUTURE JETm 2A	FUTURE JET 2A	72
FUTURE JETm 2AH	FUTURE JET 2AH	72

MATERIALS AND COMPONENTS

1 Pump body	FUTURE JET 1: cast iron with cataphoretic treatment, provided with ISO 228/1 threaded ports FUTURE JET 2: cast iron with ISO 228/1 threaded ports start of production with new design 07.2024			
2 Cover	Stainless steel AISI 304			
3 Ejector unit	Noryl™			
4 Impeller	Stainless steel AISI 304			
5 Mechanical seal	Water pump	Seal	Shaft	Materials
	FUTURE JET 1	AR-12	Ø 12 mm	Ceramic / Graphite / NBR
	FUTURE JET 2	AR-14	Ø 14 mm	Ceramic / Graphite / NBR
6 Motor shaft	Stainless steel AISI 431			
7 Electric motor	FUTURE JETm: single-phase 230 V - 50 Hz with winding integrated thermal motor protection FUTURE JET: three-phase 230/400 V - 50 Hz ※ Pumps are equipped with high-efficiency motors (IEC 60034-30-1) class IE2 for single-phase models class IE3 for three-phase models – Continuous running duty S1 – Insulation: CLASS F – Protection rating: IP X4			

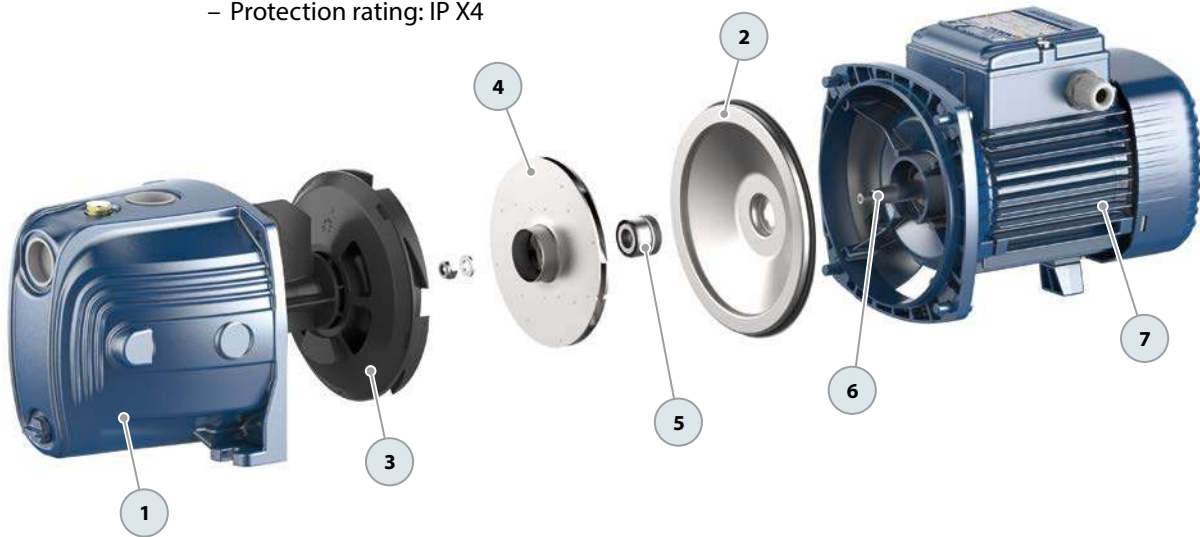

EXAMPLES OF INSTALLATION

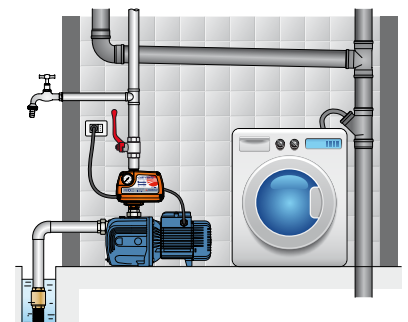
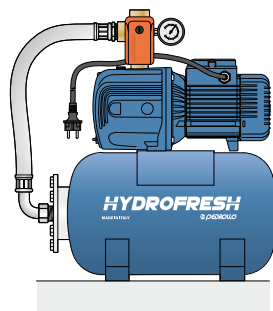
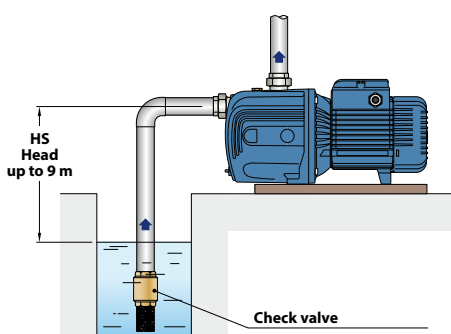

-  Clean water
-  Domestic use
-  Civil use



PERFORMANCE RANGE

- Flow rate up to **70 l/min** (4.2 m³/h)
- Head up to **58 m**

INSTALLATION AND USE

JSW self-priming pumps are designed to draw water and liquids that contain air.

They are reliable and easy to operate. They are a favorite for domestic use, particularly effective for water distribution with small to medium-sized pressure tanks and suitable for irrigation..

APPLICATION LIMITS

- Manometric suction head up to **9 m** (HS)
- Liquid temperature between **-10 °C** and **+40 °C**
- Ambient temperature up to **+40 °C**
- Maximum working pressure **6 bar**

AVAILABLE UPON REQUEST

- ✘ Technopolymer impeller (JSW X)
(cost-effective version)
- ✘ Different voltage requirements 60 Hz frequency

PATENTS - TRADE MARKS - MODELS

- **JSW**® Registered trademark No. 013073135
- Registered Community Model No. 002218610
- European Patent No. 1 510 696

EXAMPLES OF INSTALLATION

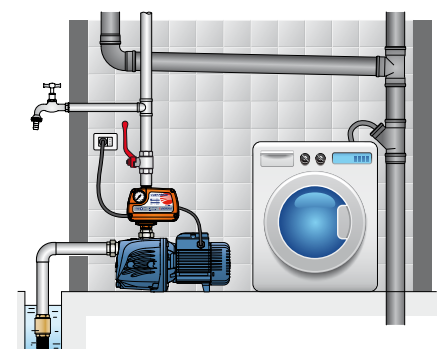
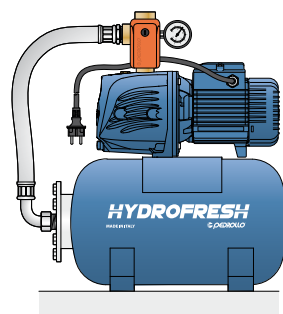
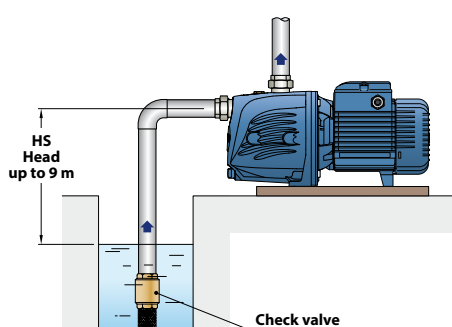

CURVES AND PERFORMANCE DATA – HS=0 m

50 Hz

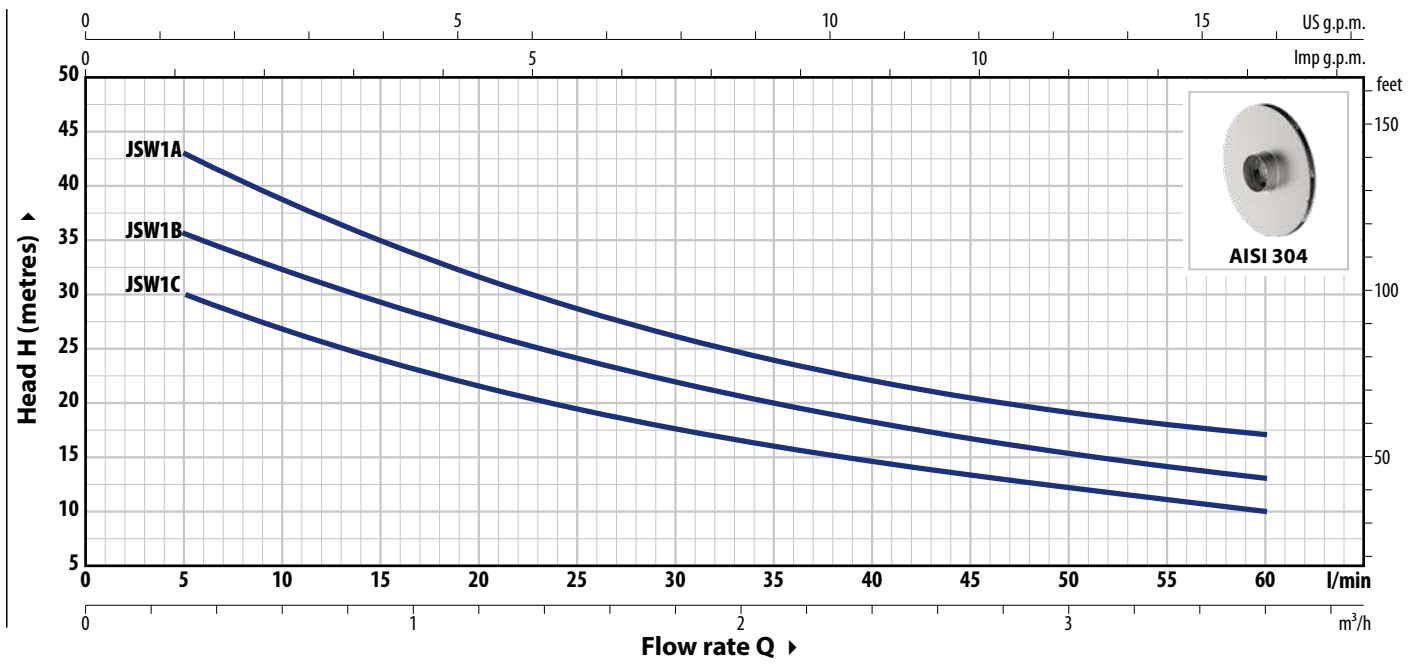

TYPE		POWER (P ₂)		1~3~	Q	m ³ /h										
Single-ph.	Three-ph.	kW	HP			0	0.3	0.6	1.2	1.5	1.8	2.4	2.7	3.0	3.6	
						0	5	10	20	25	30	40	45	50	60	
JSWm 1C	JSW 1C	0.37	0.50	IE2 IE3	H metres	34	30	27	21.7	19.5	17.7	14.7	13.4	12.2	10	
JSWm 1B	JSW 1B	0.48	0.65			39.5	35.5	32.4	26.6	24.2	22	18.3	16.7	15.3	13	
JSWm 1A	JSW 1A	0.55	0.75			48	43	39	31.5	28.5	26	22	20.5	19	17	

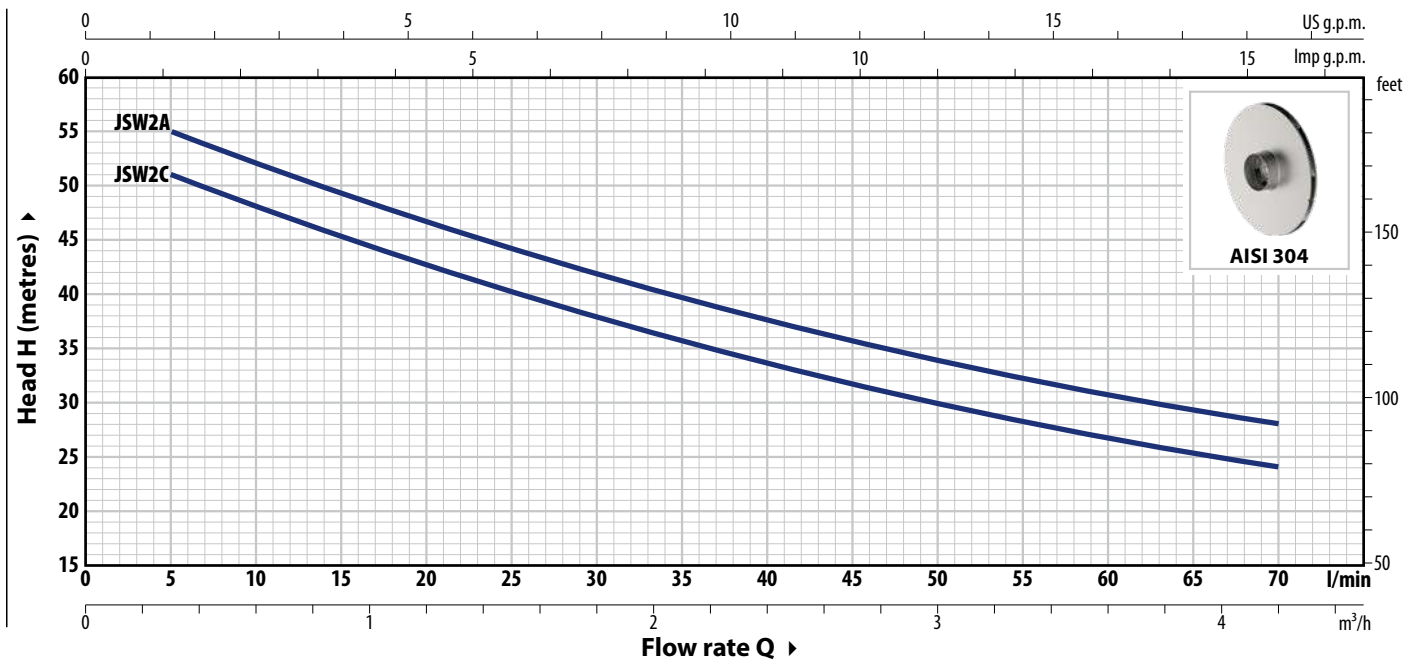

TYPE		POWER (P ₂)		1~3~	Q	m ³ /h										
Single-ph.	Three-ph.	kW	HP			0	0.3	0.6	1.2	1.8	2.4	2.7	3.0	3.6	4.2	
						0	5	10	20	30	40	45	50	60	70	
JSWm 2C	JSW 2C	0.75	1	IE2 IE3	H metres	54	51	48	42.5	38	33.5	31.5	30	26.5	24	
JSWm 2A	JSW 2A	0.90	1.25			58	55	52	46.5	42	37.5	35.5	34	31	28	

Q = Flow rate H = Total manometric head HS = Suction height

Performance curves comply with EN ISO 9906 Grade 3B tolerance limits.

ABSORPTION

TYPE	VOLTAGE
Single-ph.	230 V
JSWm 1C	2.6 A
JSWm 1B	3.2 A
JSWm 1A	3.6 A
JSWm 2C	5.8 A
JSWm 2A	6.0 A

TYPE	VOLTAGE	
Three-ph.	230 V - Δ	400 V - 人
JSW 1C	1.7 A	1.0 A
JSW 1B	2.1 A	1.2 A
JSW 1A	2.8 A	1.6 A
JSW 2C	4.7 A	2.7 A
JSW 2A	5.2 A	3.0 A

DIMENSIONS AND WEIGHT

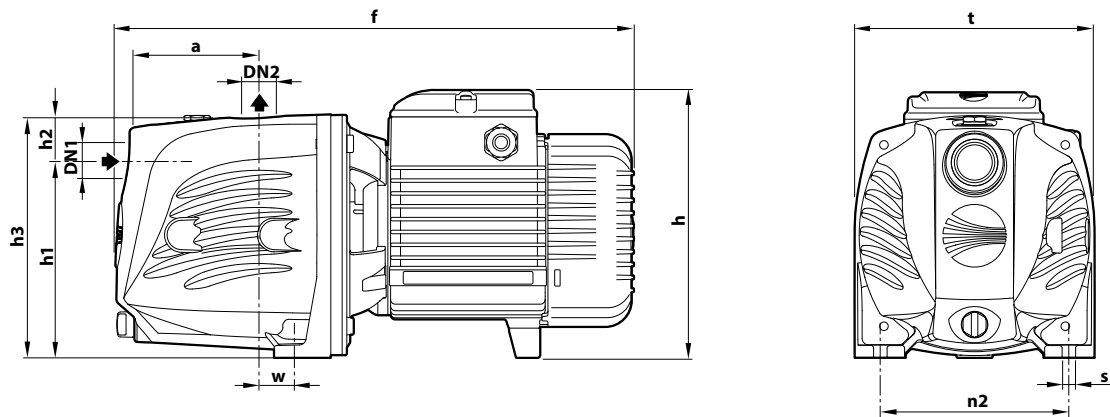

TYPE		PORTS		DIMENSIONS mm										kg	
Single-ph.	Three-ph.	DN1	DN2	a	f	h	h1	h2	h3	t	n2	w	s	1~	3~
JSWm 1C	JSW 1C	1"	1"	94	357	171	127	35	162	158	124	24	10	9.7	9.7
JSWm 1B	JSW 1B													9.8	9.8
JSWm 1A	JSW 1A													10.7	10.0
JSWm 2C	JSW 2C	1"	1"	96	389	200 *	147	33	180	180	142	22	10	14.0	14.0
JSWm 2A	JSW 2A													15.0	14.0

(*) h=220 mm for single-phase 110 V versions

PALLET CAPACITY

TYPE		NO. OF PUMPS
Single-ph.	Three-ph.	
JSWm 1C	JSW 1C	98
JSWm 1B	JSW 1B	98
JSWm 1A	JSW 1A	98
JSWm 2C	JSW 2C	72
JSWm 2A	JSW 2A	72

MATERIALS AND COMPONENTS

1 Pump body Cast iron with cataphoretic treatment, provided with ISO 228/1 threaded ports (for JSW 1)
Cast iron with ISO 228/1 threaded ports (for JSW 2)

2 Cover Stainless steel **AISI 304**

3 Ejector unit Noryl™

4 Impeller Stainless steel **AISI 304**

5 Mechanical seal	Water pump	Seal	Shaft	Materials
	JSW1	AR-12	Ø 12 mm	Ceramic / Graphite / NBR
JSW2	AR-14	Ø 14 mm	Ceramic / Graphite / NBR	

6 Motor shaft Stainless steel **AISI 431**

7 Electric motor **JSWm**: single-phase 230 V - 50 Hz with winding integrated thermal motor protection
JSW: three-phase 230/400 V - 50 Hz
※ Pumps are equipped with high-efficiency motors (IEC 60034-30-1)
class **IE2** for single-phase models
class **IE3** for three-phase models
– Continuous running duty **S1**
– Insulation: CLASS F
– Protection rating: IP X4

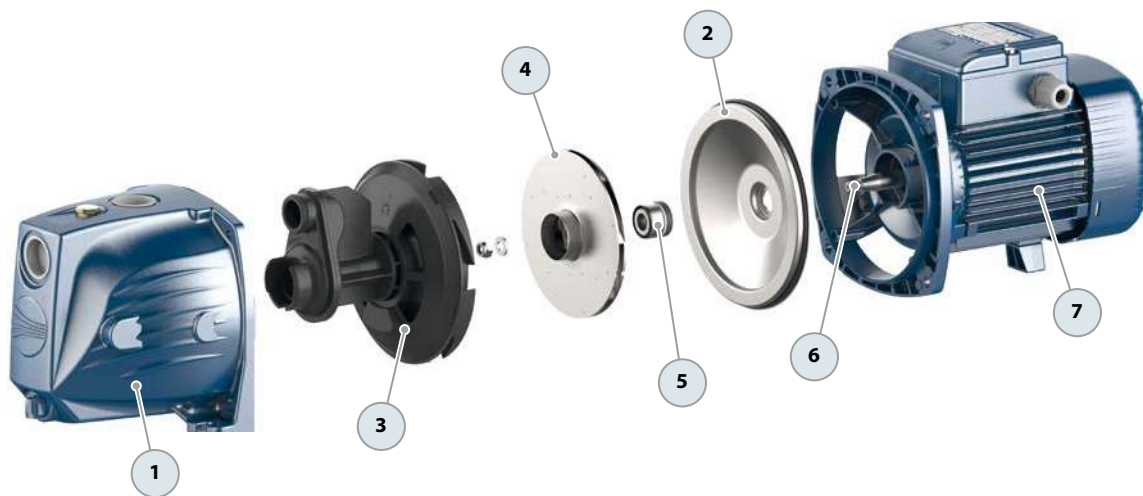

-  Clean water
-  Domestic use
-  Civil use
-  Industrial use



PERFORMANCE RANGE

- Flow rate up to **160 l/min** (9.6 m³/h)
- Head up to **97 m**

INSTALLATION AND USE

JSW self-priming pumps are designed to draw water and liquids that contain air.

They are reliable and easy to operate. They are a favorite for domestic use, particularly effective for water distribution with small to medium-sized pressure tanks and suitable for irrigation.

APPLICATION LIMITS

- Manometric suction head up to **9 m (HS)**
- Liquid temperature between **-10 °C** and **+40 °C**
- Ambient temperature up to **+40 °C**
- Maximum working pressure **10 bar**

AVAILABLE UPON REQUEST

- ✘ IPX5 protection
- ✘ Different voltage requirements 60 Hz frequency

PATENTS - TRADE MARKS - MODELS

- JSW®Registered trademark No. 013073135
- Registered Community Model No. 002218610

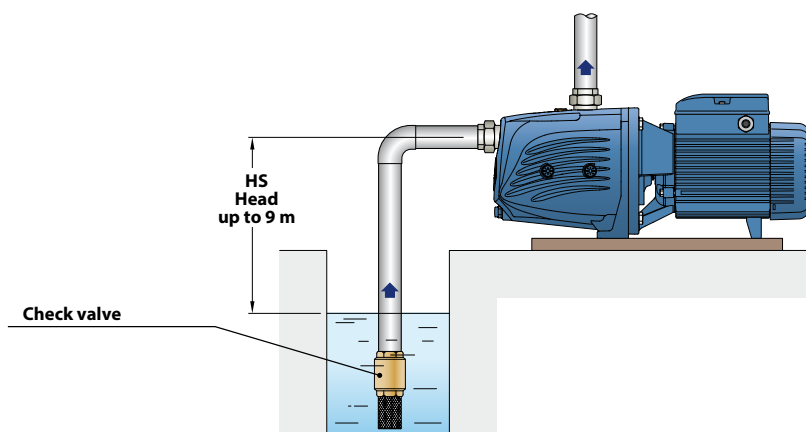

CURVES AND PERFORMANCE DATA – HS=0 m

50 Hz

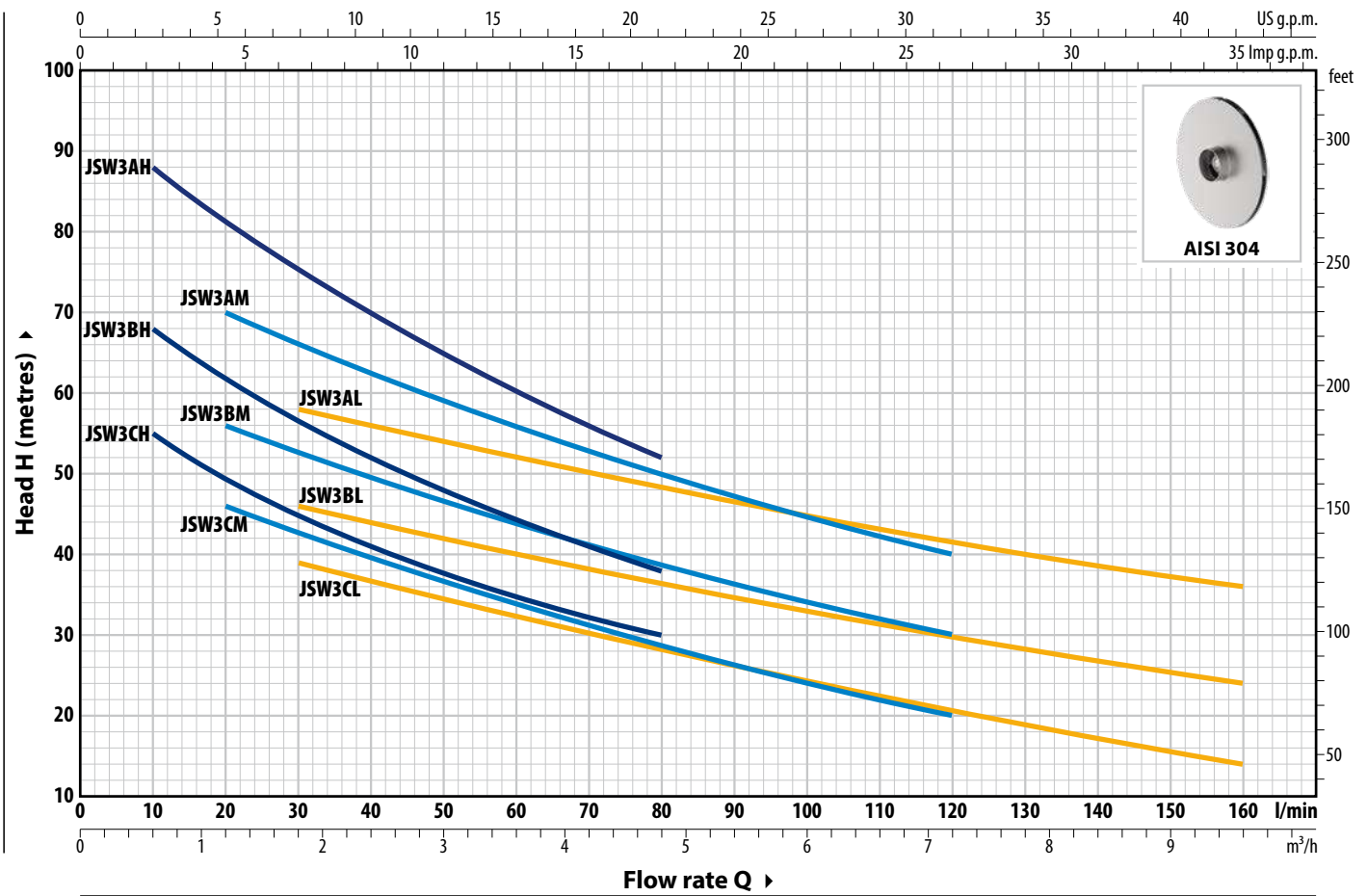

TYPE		POWER (P ₂)		1~3~	Q	m ³ /h															
Single-ph.	Three-ph.	kW	HP			0	0.6	1.2	1.8	2.4	3.0	3.6	4.2	4.8	6.0	7.2	8.4	9.6			
					Q	0	10	20	30	40	50	60	70	80	100	120	140	160			
JSWm 3CH	JSW 3CH	1.1	1.5	IE2 IE3	H metres	62	55	49	45	41	38	35	32	30							
JSWm 3BH	JSW 3BH	1.5	2			73	68	62	56.5	52	48	44	41	38							
JSWm 3AH	JSW 3AH	2.2	3			97	88	81	75	70	65	60.5	56	52							
JSWm 3CM	JSW 3CM	1.1	1.5			54	-	46	43	39.5	36.5	34	31	28.5	24	20					
JSWm 3BM	JSW 3BM	1.5	2			63	-	56	53	49.5	47.5	44	41	39	34	30					
JSWm 3AM	JSW 3AM	2.2	3			78	-	70	66	62	59	56	53	50	45	40					
JSWm 3CL	JSW 3CL	1.1	1.5			44	-	-	39	37	34	32	30	28	24	21	17	14			
JSWm 3BL	JSW 3BL	1.5	2			51	-	-	46	44	42	40	38	36	33	30	27	24			
JSWm 3AL	JSW 3AL	2.2	3			64	-	-	58	56	54	52	50	48	45	41.5	38.5	36			

Q = Flow rate H = Total manometric head HS = Suction height

Performance curves comply with EN ISO 9906 Grade 3B tolerance limits.

ABSORPTION

TYPE	VOLTAGE
Single-phase	230 V
JSWm 3CH	8.1 A
JSWm 3BH	9.5 A
JSWm 3AH	12.7 A
JSWm 3CM	8.1 A
JSWm 3BM	9.7 A
JSWm 3AM	13.0 A
JSWm 3CL	8.1 A
JSWm 3BL	10.1 A
JSWm 3AL	13.6 A

TYPE	VOLTAGE	
Three-phase	230 V - Δ	400 V - 人
JSW 3CH	5.2 A	3.0 A
JSW 3BH	6.1 A	3.5 A
JSW 3AH	8.8 A	5.1 A
JSW 3CM	5.2 A	3.0 A
JSW 3BM	6.1 A	3.5 A
JSW 3AM	9.0 A	5.2 A
JSW 3CL	5.2 A	3.0 A
JSW 3BL	6.4 A	3.7 A
JSW 3AL	9.3 A	5.4 A

DIMENSIONS AND WEIGHT

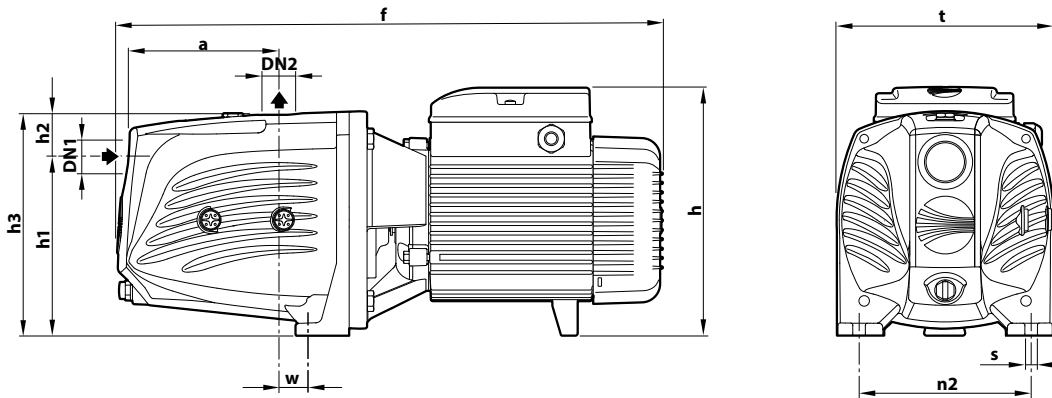

TYPE		PORTS		DIMENSIONS mm										kg	
Single-phase	Three-phase	DN1	DN2	a	f	h	h1	h2	h3	t	n2	w	s	1~	3~
JSWm 3CH	JSW 3CH	1 1/4"	1"	143	522	240	165	39	204	206	164	30	11	24.5	24.4
JSWm 3BH	JSW 3BH				542									25.6	25.7
JSWm 3AH	JSW 3AH				542									28.4	28.4
JSWm 3CM	JSW 3CM				522									24.6	24.4
JSWm 3BM	JSW 3BM				542									25.7	25.7
JSWm 3AM	JSW 3AM				522									28.4	28.4
JSWm 3CL	JSW 3CL				522									24.5	24.4
JSWm 3BL	JSW 3BL				542									25.8	25.7
JSWm 3AL	JSW 3AL				542									28.4	28.4

PALLET CAPACITY

TYPE		NO. OF PUMPS
Single-phase	Three-phase	
JSWm 3CH	JSW 3CH	35
JSWm 3BH	JSW 3BH	35
JSWm 3AH	JSW 3AH	35
JSWm 3CM	JSW 3CM	35
JSWm 3BM	JSW 3BM	35
JSWm 3AM	JSW 3AM	35
JSWm 3CL	JSW 3CL	35
JSWm 3BL	JSW 3BL	35
JSWm 3AL	JSW 3AL	35

MATERIALS AND COMPONENTS

1 Pump body	Cast iron with cathaphoresis treatment, provided with ISO 228/1 threaded ports		
2 Cover	Cast iron with cathaphoresis treatment		
3 Ejector unit	Noryl™		
4 Impeller	Stainless steel AISI 304		
5 Mechanical seal	Seal	Shaft	Materials
	FN-18	Ø 18 mm	Graphite / Ceramic / NBR
6 Motor shaft	Stainless steel AISI 431		
7 Electric motor	<p>JSWm: single-phase 230 V - 50 Hz with winding integrated thermal motor protection</p> <p>JSW: three-phase 230/400 V - 50 Hz</p> <p>※ Pumps are equipped with high-efficiency motors (IEC 60034-30-1)</p> <p>class IE2 for single-phase models</p> <p>class IE3 for three-phase models</p> <ul style="list-style-type: none"> – Continuous running duty S1 – Insulation: CLASS F – Protection rating: IP X4 		

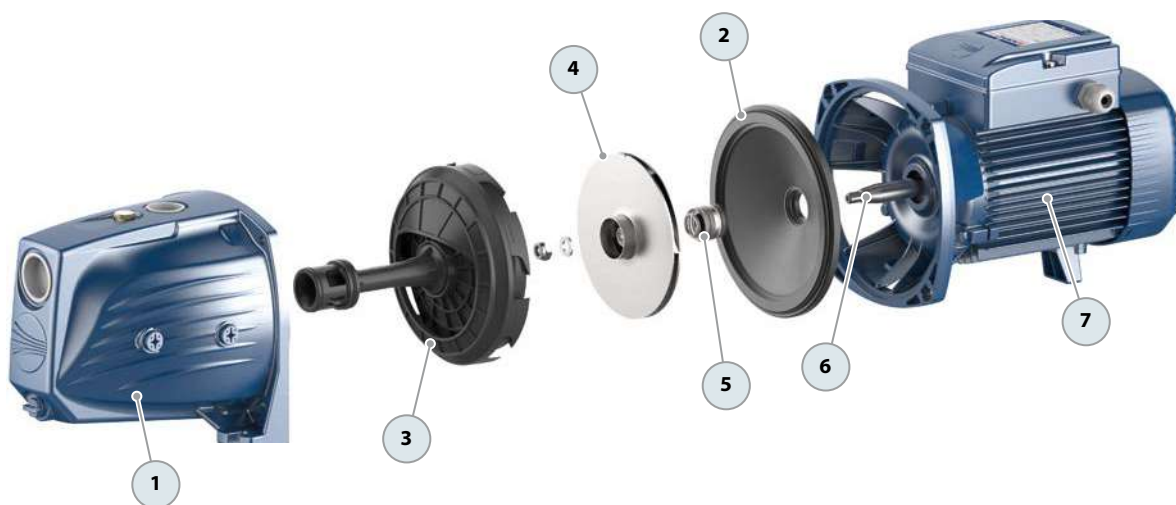

-  Clean water
-  Domestic use
-  Civil use

※ **Reduction of energy consumption by up to 50%**



From an evolution of the classic JET pump concept, a SUPER JET was born.

- ※ **Stainless steel pump body and impeller**
- ※ **Better consumption/performance ratio**
- ※ **High hydraulic efficiency**
- ※ **Noise reduction**

PERFORMANCE RANGE

- Flow rate up to **120 l/min** (7.2 m³/h)
- Head up to **59 m**

FUTURE JET-ST

Developed by our innovative research and development team, this pump revolutionizes the classic self-priming design.

With an international registered patent, the **FUTURE JET-ST** not only matches the pressure of a traditional JET pump, it surpasses it. Moreover, it doubles the flow rate while reducing energy consumption by up to 50%.

INSTALLATION AND USE

FUTURE JET-ST self-priming pumps are designed to draw water and liquids that contain air.

They are reliable and easy to operate. They are a favorite for domestic use, particularly effective for water distribution with small to medium-sized pressure tanks and suitable for irrigation.

APPLICATION LIMITS

- Manometric suction head up to **9 m** (HS)

- Liquid temperature between **-10 °C** and **+40 °C**
- Ambient temperature up to **+40 °C**
- Maximum working pressure **6 bar**

AVAILABLE UPON REQUEST

- ※ Technopolymer impeller (cost-effective version)
- ※ Different voltage requirements 60 Hz frequency

PATENTS - TRADE MARKS - MODELS

- FUTURE JET® Registered Trade mark No. 018198453
- European Patent No. 1 510 696
- Patent No. PCT/IT2019/050168

CURVES AND PERFORMANCE DATA – HS=0 m

50 Hz

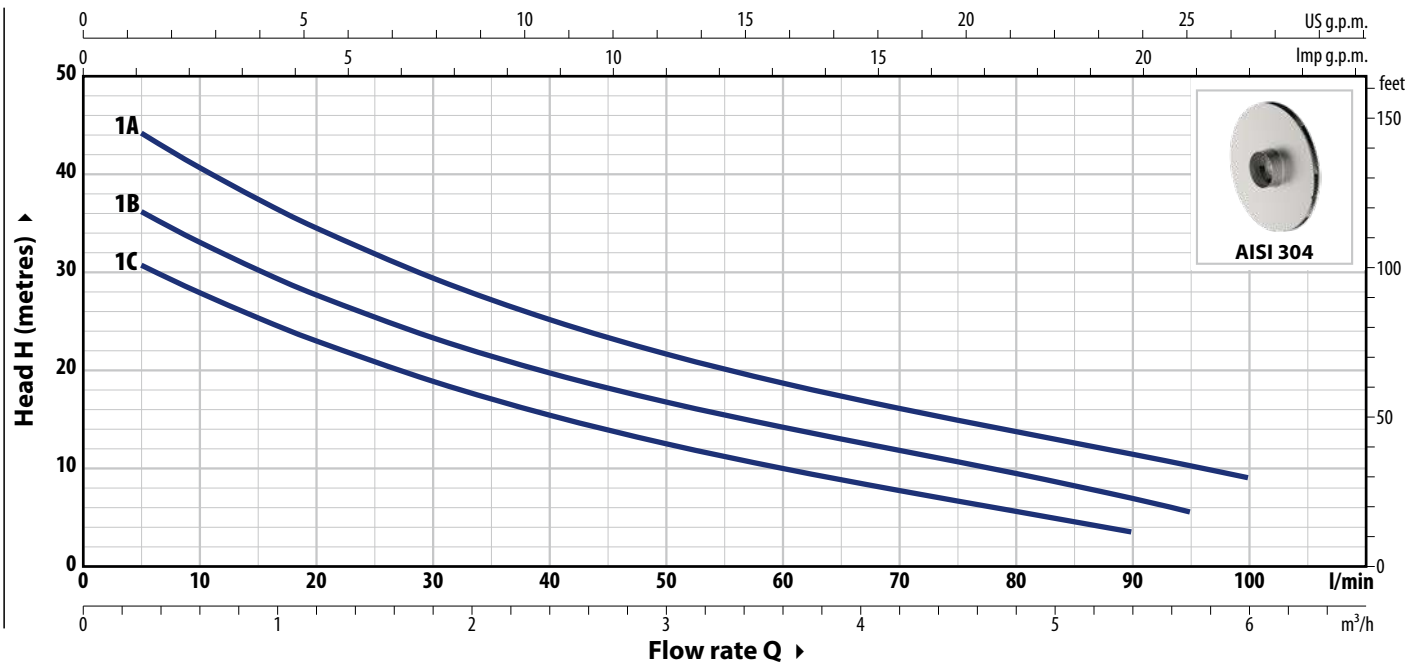

TYPE		POWER (P ₂)		1~3~	Q	Flow rate											
Single-phase	Three-phase	kW	HP			m ³ /h	0	0.3	0.6	1.2	2.4	3.6	4.8	5.4	5.7	6.0	
FUTURE JETm 1C-ST	FUTURE JET 1C-ST	0.37	0.50	IE2 IE3	H metres	0	5	10	20	40	60	80	90	95	100		
FUTURE JETm 1B-ST	FUTURE JET 1B-ST	0.48	0.65			33.5	30.5	28	23	15.4	10	6	3.5				
FUTURE JETm 1A-ST	FUTURE JET 1A-ST	0.55	0.75			40	36	33	27.6	19.7	14.2	9.5	7	5.5			
						48	44	40.6	34.5	25.2	18.7	13.7	11.4	10.2	9		

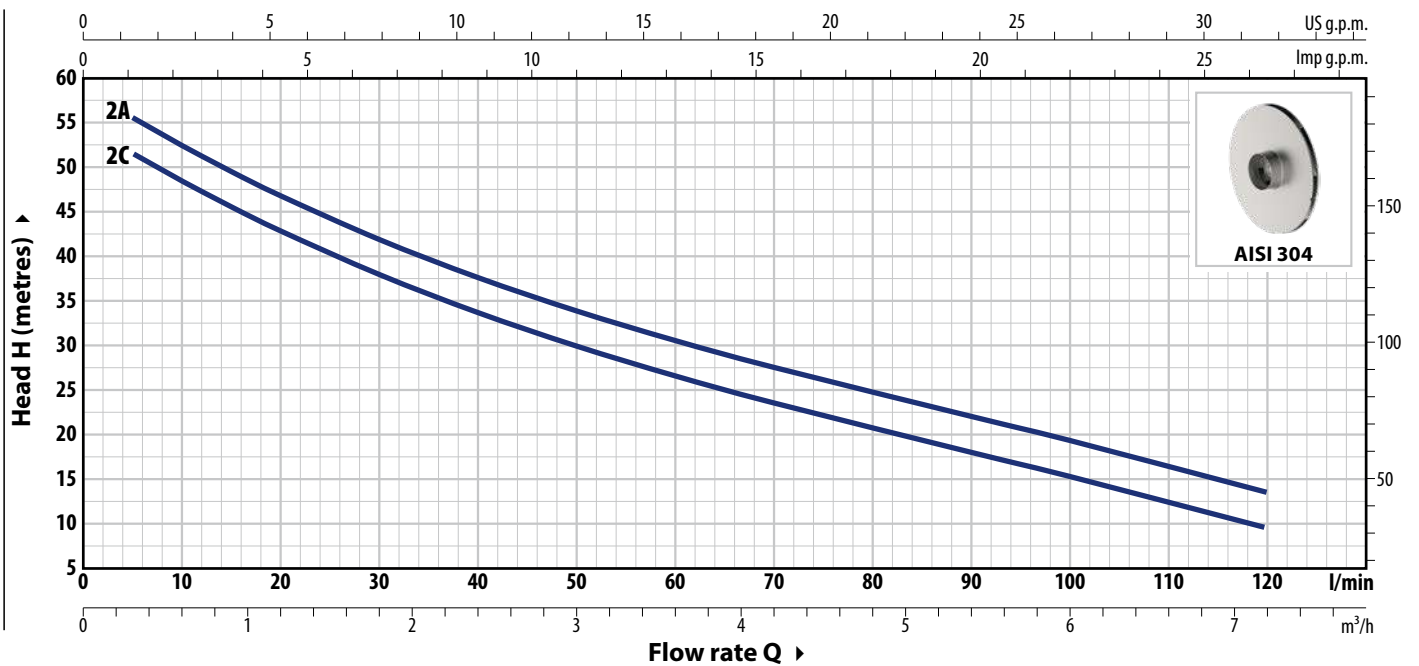

TYPE		POWER (P ₂)		1~3~	Q	Flow rate											
Single-phase	Three-phase	kW	HP			m ³ /h	0	0.3	0.6	1.2	2.4	3.6	4.8	5.4	5.7	6.0	7.2
FUTURE JETm 2C-ST	FUTURE JET 2C-ST	0.75	1	IE2 IE3	H metres	0	5	10	20	40	60	80	90	95	100	120	
FUTURE JETm 2A-ST	FUTURE JET 2A-ST	0.90	1.25			55	52	49	43	34	27	20.5	18.3	17	15.5	10	
						59	56	53	47	38	32	25	22.3	21	19.5	13.7	

Q = Flow rate H = Total manometric head HS = Suction height

Performance curves comply with EN ISO 9906 Grade 3B tolerance limits.

ABSORPTION

TYPE	VOLTAGE
Single-phase	230 V
FUTURE JETm 1C-ST	2.6 A
FUTURE JETm 1B-ST	3.2 A
FUTURE JETm 1A-ST	4.0 A
FUTURE JETm 2C-ST	5.8 A
FUTURE JETm 2A-ST	6.6 A

TYPE	VOLTAGE	
	230 V - Δ	400 V - Y
FUTURE JET 1C-ST	1.7 A	1.0 A
FUTURE JET 1B-ST	2.1 A	1.2 A
FUTURE JET 1A-ST	2.8 A	1.6 A
FUTURE JET 2C-ST	4.7 A	2.7 A
FUTURE JET 2A-ST	5.2 A	3.0 A

DIMENSIONS AND WEIGHT

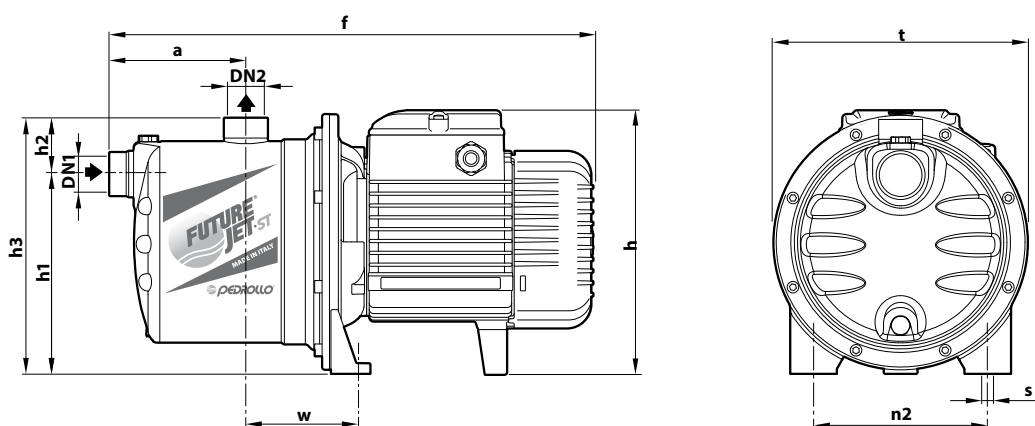

TYPE	PORTS	DIMENSIONS mm												kg			
		DN1	DN2	a	f	h	h1	h2	h3	t	n2	w	s	1~	3~		
Single-phase																	
Three-phase																	
FUTURE JETm 1C-ST	FUTURE JET 1C-ST															7.1	7.1
FUTURE JETm 1B-ST	FUTURE JET 1B-ST	1"	1"	113	367	183	132	51	183	182	120	87	9		7.1	7.1	
FUTURE JETm 1A-ST	FUTURE JET 1A-ST														7.8	7.1	
FUTURE JETm 2C-ST	FUTURE JET 2C-ST	1"	1"	111	393	217*	162	46	208	208	142	91	10		11.2	11.2	
FUTURE JETm 2A-ST	FUTURE JET 2A-ST														12.0	11.2	

(*) h=236 mm for single-phase 110 V versions

PALLET CAPACITY

TYPE	NO. OF PUMPS
Single-phase	
Three-phase	
FUTURE JETm 1C-ST	84
FUTURE JETm 1B-ST	84
FUTURE JETm 1A-ST	84
FUTURE JETm 2C-ST	60
FUTURE JETm 2A-ST	60

MATERIALS AND COMPONENTS

1 Pump body	Stainless steel AISI 304 , provided with ISO 228/1 threaded ports			
2 Cover	Stainless steel AISI 304			
3 Ejector unit	Noryl™			
4 Impeller	Stainless steel AISI 304			
5 Mechanical seal	Water pump	Seal	Shaft	Materials
	FUTURE JET 1-ST	AR-12	Ø 12 mm	Ceramic / Graphite / NBR
	FUTURE JET 2-ST	AR-14	Ø 14 mm	Ceramic / Graphite / NBR
6 Motor shaft	Stainless steel AISI 431			
7 Electric motor	<p>FUTURE JETm-ST: single-phase 230 V - 50 Hz with winding integrated thermal motor protection</p> <p>FUTURE JET-ST: three-phase 230/400 V - 50 Hz</p> <p>※ Pumps are equipped with high-efficiency motors (IEC 60034-30-1) class IE2 for single-phase models class IE3 for three-phase models</p> <ul style="list-style-type: none"> – Continuous running duty S1 – Insulation: CLASS F – Protection rating: IP X4 			

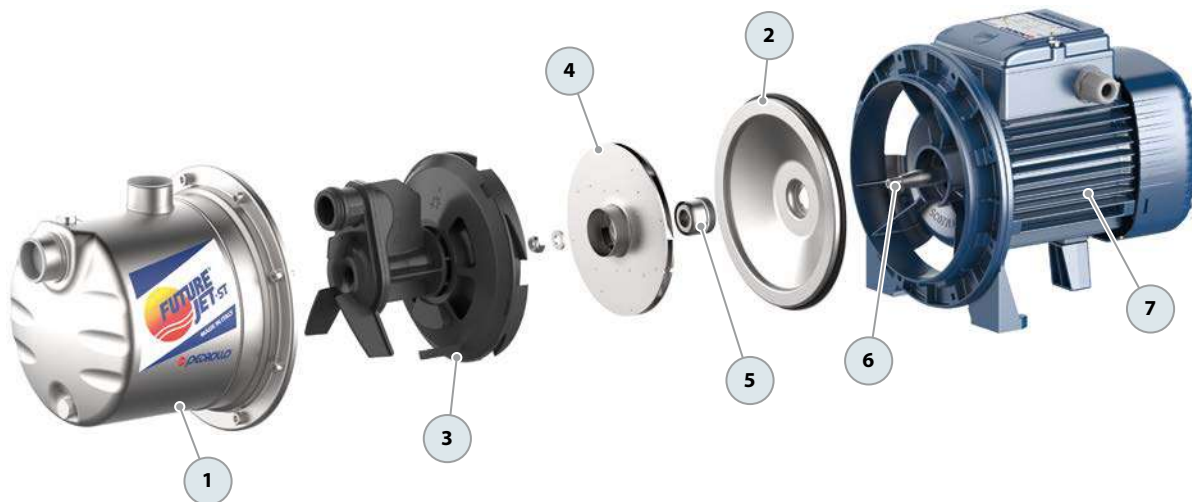

EXAMPLES OF INSTALLATION

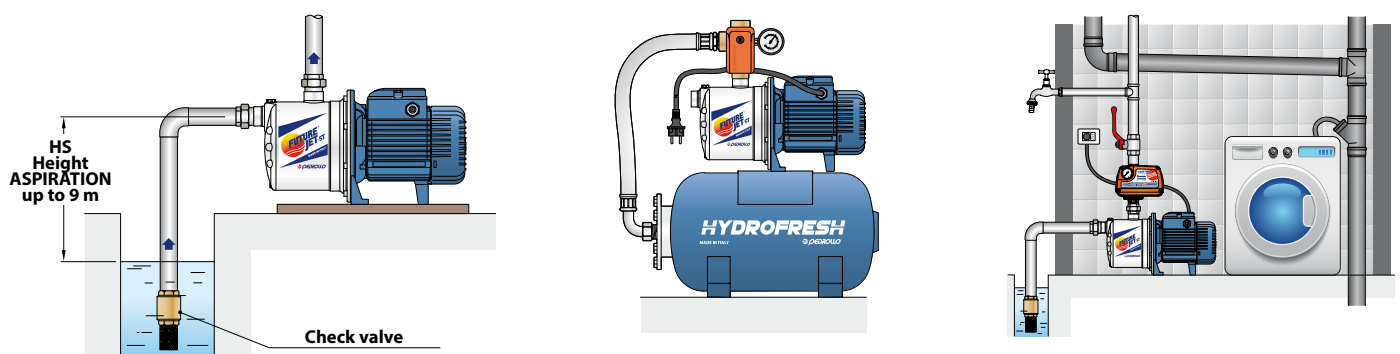

-  Clean water
-  Domestic use
-  Civil use



PERFORMANCE RANGE

- Flow rate up to **70 l/min** (4.2 m³/h)
- Head up to **60 m**

INSTALLATION AND USE

JCR self-priming pumps are designed to draw water and liquids that contain air.

They are reliable and easy to operate. They are a favorite for domestic use, particularly effective for water distribution with small to medium-sized pressure tanks and suitable for irrigation.

APPLICATION LIMITS

- Manometric suction head up to **9 m** (HS)
- Liquid temperature between **-10 °C** and **+40 °C**
- Ambient temperature up to **+40 °C**
- Maximum working pressure **6 bar**

AVAILABLE UPON REQUEST

- ✘ Different voltage requirements 60 Hz frequency
- ✘ Certified pumps 

PATENTS - TRADE MARKS - MODELS

- European Patent No. 1 510 696

EXAMPLES OF INSTALLATION

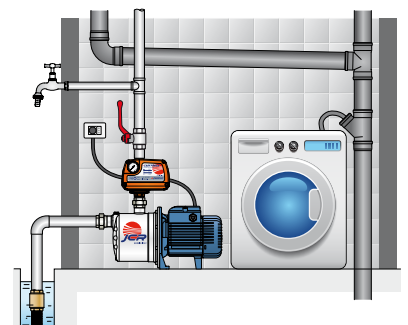
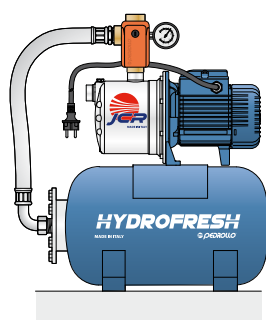
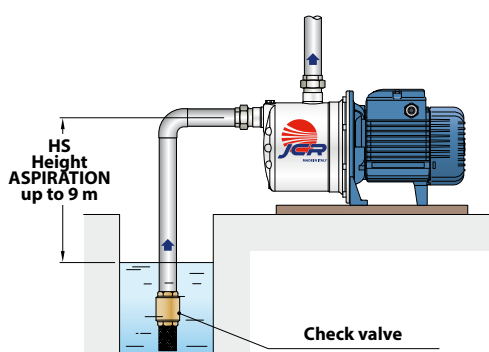

CURVES AND PERFORMANCE DATA – HS=0 m

50 Hz

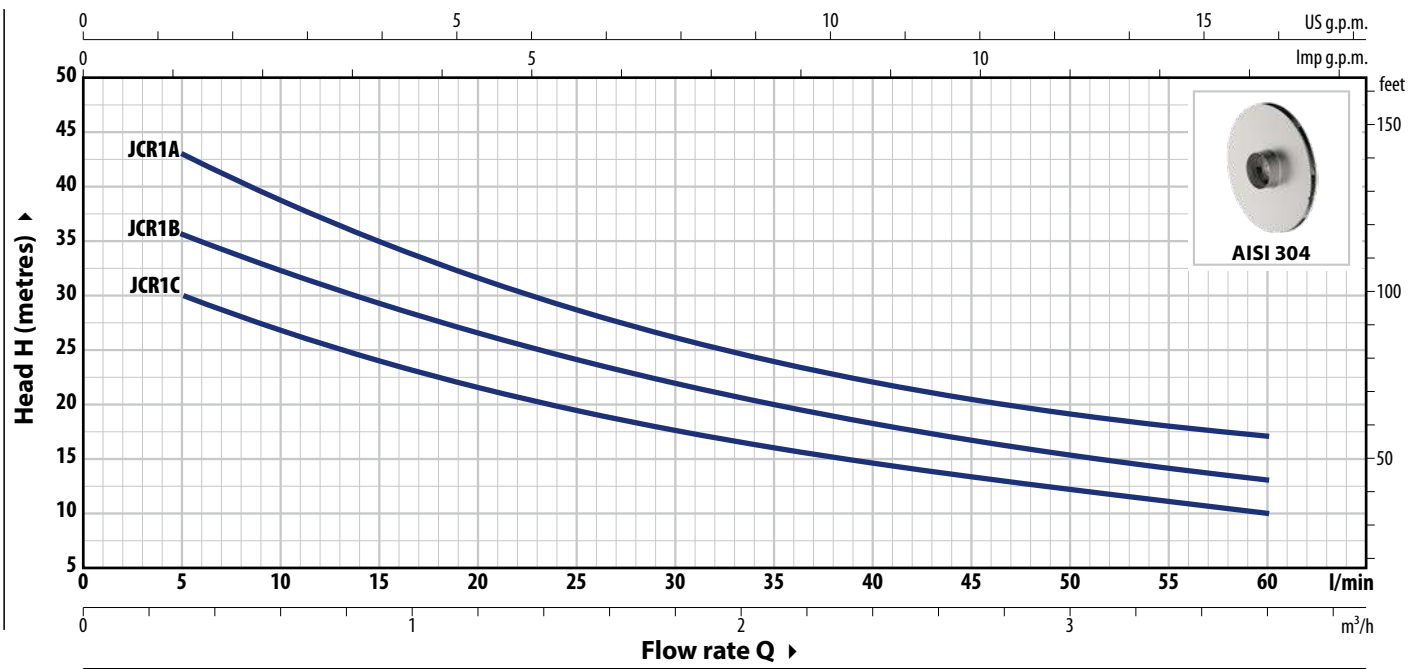

TYPE		POWER (P ₂)		1~3~	Q	m ³ /h												
Single-ph.	Three-ph.	kW	HP			0	0.3	0.6	1.2	1.5	1.8	2.4	2.7	3.0	3.6			
						0	5	10	20	25	30	40	45	50	60			
JCRm 1C	JCR 1C	0.37	0.50	IE2 IE3	H metres	34	30	27	21.7	19.5	17.7	14.7	13.4	12.2	10			
JCRm 1B	JCR 1B	0.48	0.65			39.5	35.5	32.4	26.6	24.2	22	18.3	16.7	15.3	13			
JCRm 1A	JCR 1A	0.55	0.75			48	43	39	31.5	28.5	26	22	20.5	19	17			

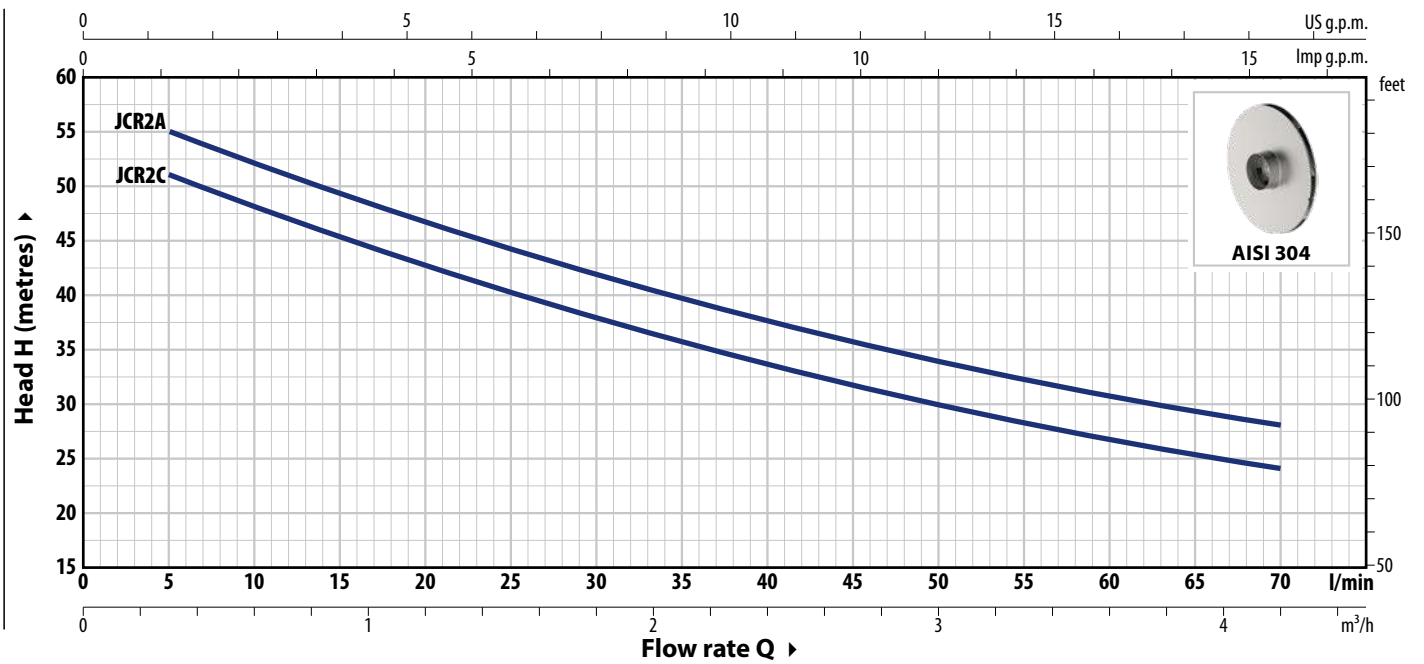

TYPE		POWER (P ₂)		1~3~	Q	m ³ /h												
Single-ph.	Three-ph.	kW	HP			0	0.3	0.6	1.2	1.8	2.4	2.7	3.0	3.6	4.2			
						0	5	10	20	30	40	45	50	60	70			
JCRm 2C	JCR 2C	0.75	1	IE2 IE3	H metres	54	51	48	42.5	38	33.5	31.5	30	26.5	24			
JCRm 2A	JCR 2A	0.90	1.25			58	55	52	46.5	42	37.5	35.5	34	31	28			

Q = Flow rate H = Total manometric head HS = Suction height

Performance curves comply with EN ISO 9906 Grade 3B tolerance limits.

ABSORPTION

TYPE	VOLTAGE
Single-ph.	230 V
JCRm 1C	2.6 A
JCRm 1B	3.2 A
JCRm 1A	3.6 A
JCRm 2C	5.8 A
JCRm 2A	6.2 A

TYPE	VOLTAGE	
Three-ph.	230 V - Δ	400 V - 人
JCR 1C	1.7 A	1.0 A
JCR 1B	2.1 A	1.2 A
JCR 1A	2.8 A	1.6 A
JCR 2C	4.7 A	2.7 A
JCR 2A	5.2 A	3.0 A

DIMENSIONS AND WEIGHT

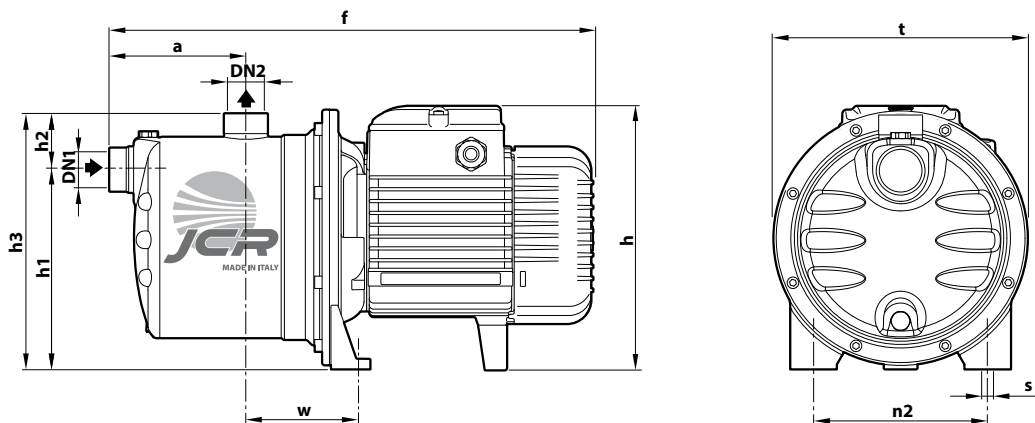

TYPE		PORTS		DIMENSIONS mm										kg	
Single-ph.	Three-ph.	DN1	DN2	a	f	h	h1	h2	h3	t	n2	w	s	1~	3~
JCRm 1C	JCR 1C	1"	1"	113	367	183	132	51	183	182	120	87	9	7.1	7.1
JCRm 1B	JCR 1B													7.1	7.1
JCRm 1A	JCR 1A													7.8	7.1
JCRm 2C	JCR 2C	1"	1"	111	393	217 *	162	46	208	208	142	91	10	11.2	11.2
JCRm 2A	JCR 2A													12.0	11.2

(*) h=236 mm for single-phase 110 V versions

PALLET CAPACITY

TYPE		NO. OF PUMPS
Single-ph.	Three-ph.	
JCRm 1C	JCR 1C	84
JCRm 1B	JCR 1B	84
JCRm 1A	JCR 1A	84
JCRm 2C	JCR 2C	60
JCRm 2A	JCR 2A	60

MATERIALS AND COMPONENTS

1 Pump body Stainless steel **AISI 304**, provided with ISO 228/1 threaded ports

2 Cover Stainless steel **AISI 304**

3 Ejector unit Noryl™

4 Impeller Stainless steel **AISI 304**

5 Mechanical seal	Water pump	Seal	Shaft	Materials
	JCR1	AR-12	Ø 12 mm	Ceramic / Graphite / NBR
JCR2	AR-14	Ø 14 mm	Ceramic / Graphite / NBR	

6 Motor shaft Stainless steel **AISI 431**

7 Electric motor

JCRm: single-phase 230 V - 50 Hz with winding integrated thermal motor protection
JCR: three-phase 230/400 V - 50 Hz

※ Pumps are equipped with high-efficiency motors (IEC 60034-30-1)
 class **IE2** for single-phase models
 class **IE3** for three-phase models

- Continuous running duty **S1**
- Insulation: CLASS F
- Protection rating: IP X4

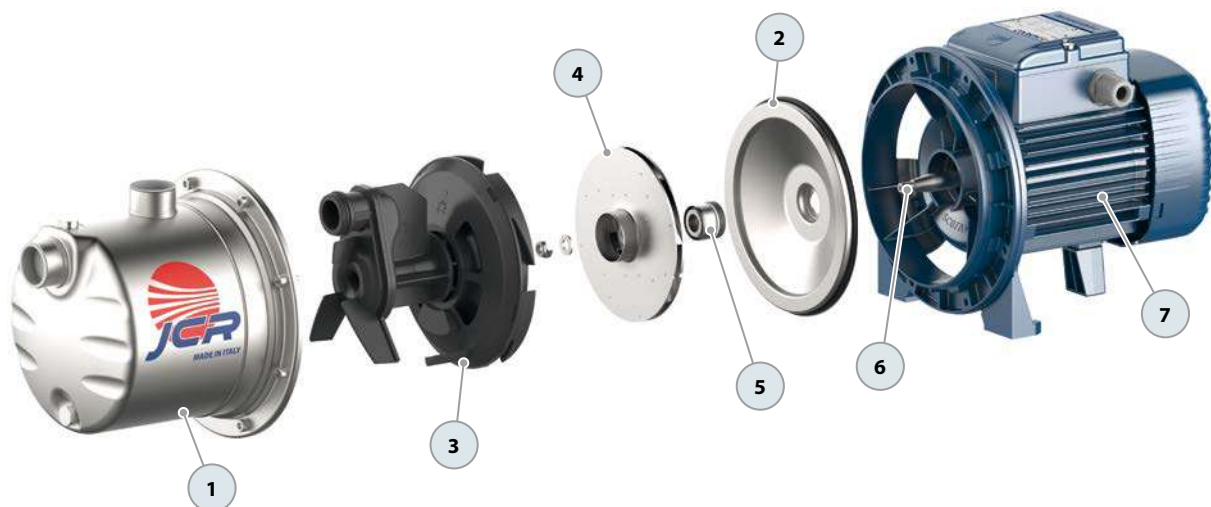



※ For pools up to 180 m³



- ※ Robust electric pumps constructed with high-quality components and thick materials for extended durability and quiet operation.
- ※ High water flow rate paired with low energy consumption.
- ※ Double insulation between the pump and electric motor ensures maximum safety, with the pump/motor shaft always insulated from water.

- ※ Pre-filter equipped with a transparent cover for easy visual inspection, featuring an extra-large filter basket to reduce cleaning frequency.
- ※ High resistance to heat, chemicals, and salt corrosion.
- ※ Supplied with 2" GAS threaded ISO 228/1 connection fittings and AISI 316 screws

PERFORMANCE RANGE

- Flow rate up to **700 l/min** (42 m³/h)
- Head up to **23 m**

INSTALLATION AND USE

Self-priming pump with a built-in filter, designed for water circulation in residential swimming pools up to 180 m³.

APPLICATION LIMITS

- Swimming pool water (pH 6.5-8.4).
- Manometric suction head up to **4 m** (HS)
- Liquid temperature up to **+45 °C**
- Ambient temperature up to **+50 °C**
- Maximum working pressure **2.5 bar**

ELECTRIC MOTOR

The three-phase pumps are equipped with newly developed electric motors designed to work with inverters, which guarantee stable and quiet operation.

Efficiency class **IE3** for three-phase motors, **IE2** for single-phase motors, class F insulation and IP55 protection.

AVAILABLE UPON REQUEST

- ※ Different voltage requirements 60 Hz frequency
- ※ Smooth connection fitting **63 mm**
- ※ Smooth connection fitting **2" BS**
- ※ Threaded connection fitting **2" NPT**

PATENTS - TRADE MARKS - MODELS

- **MAGNIFICA**® Registered trademark no. 018159079
- Registered Community Model No. 007671839

CURVES AND PERFORMANCE DATA – HS=0 m

50 Hz

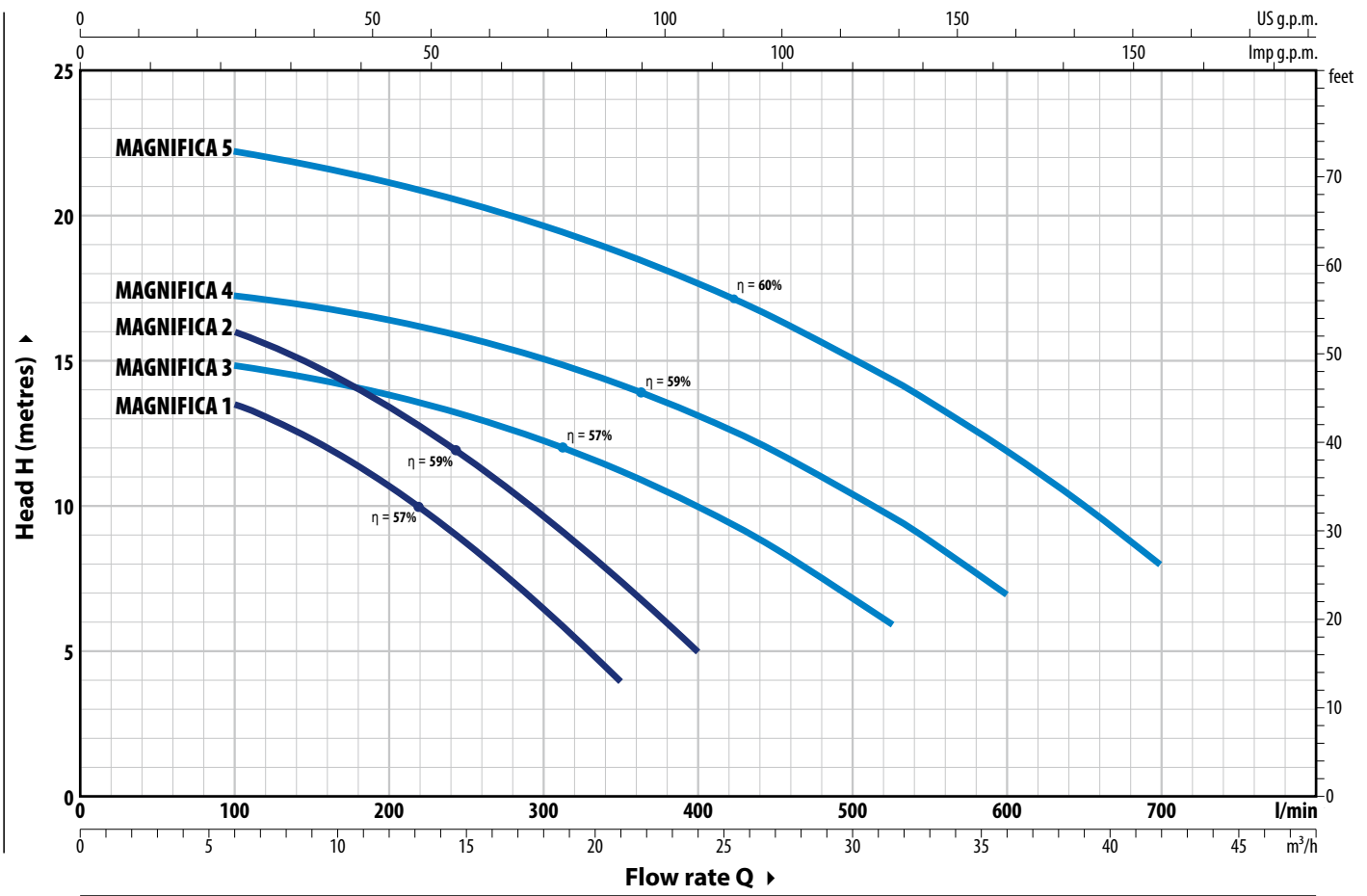

TYPE		POWER (P ₂)		1~	3~	Q	H metres											
Single-phase	Three-phase	kW	HP				0	6.0	9.0	12	15	18	21	24	30	36	42	
						l/min	0	100	150	200	250	300	350	400	525	600	700	
MAGNIFICA 1m	MAGNIFICA 1	0.55	0.75				14.5	13.5	12.3	10.7	8.8	6.5	4					
MAGNIFICA 2m	MAGNIFICA 2	0.75	1				17	16	15	13.5	11.7	9.7	7.4	5				
MAGNIFICA 3m	MAGNIFICA 3	1.1	1.5	IE2	IE3		15.5	15	14.4	14	13.2	12.3	11.3	10	6			
MAGNIFICA 4m	MAGNIFICA 4	1.5	2				17.7	17.3	17	16.4	15.8	15	14.2	13	9.6	7		
MAGNIFICA 5m	MAGNIFICA 5	2.2	3				23	22.2	21.8	21.2	20.5	19.7	18.8	17.7	14.4	12	8	

Q = Flow rate H = Total manometric head HS = Suction height

Performance curves comply with EN ISO 9906 Grade 3B tolerance limits.

ABSORPTION

TYPE	VOLTAGE
Single-phase	230 V
MAGNIFICA 1m	4.2 A
MAGNIFICA 2m	5.6 A
MAGNIFICA 3m	8.2 A
MAGNIFICA 4m	9.7 A
MAGNIFICA 5m	13.0 A

TYPE	VOLTAGE	
Three-phase	230 V - Δ	400 V - Y
MAGNIFICA 1	2.8 A	1.6 A
MAGNIFICA 2	3.6 A	2.1 A
MAGNIFICA 3	5.4 A	3.1 A
MAGNIFICA 4	7.3 A	4.2 A
MAGNIFICA 5	8.6 A	5.0 A

DIMENSIONS AND WEIGHT

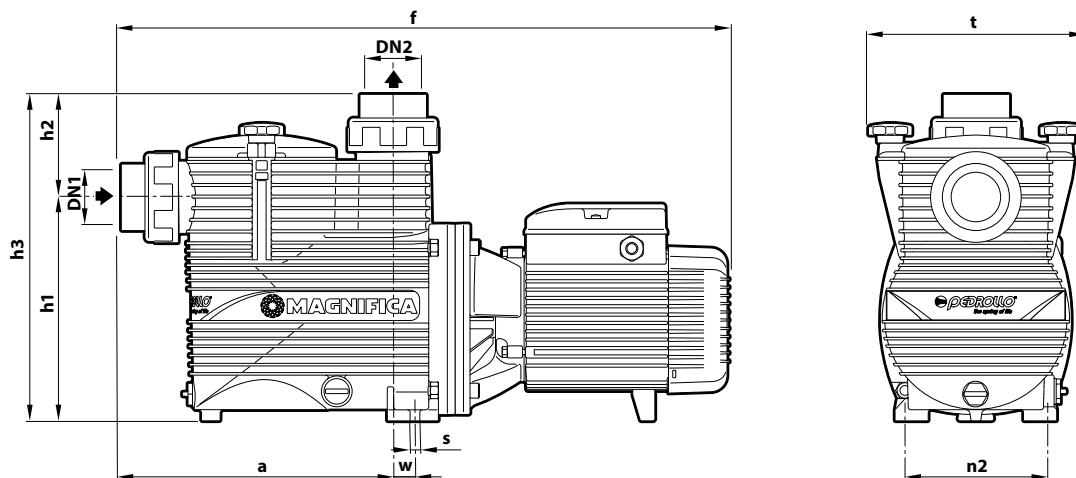

TYPE		PORTS		DIMENSIONS mm									kg	
Single-phase	Three-phase	DN1	DN2	a	f	h1	h2	h3	n1	w	s	t	1~	3~
MAGNIFICA 1m	MAGNIFICA 1	2"	2"	294	583	240	113	353	155	4.3	10.5	235	14.1	14.1
MAGNIFICA 2m	MAGNIFICA 2			294	657	240	113	353	155	15.8	10.5	235	15.0	15.0
MAGNIFICA 3m	MAGNIFICA 3			294	657	240	113	353	155	15.8	10.5	235	19.4	19.4
MAGNIFICA 4m	MAGNIFICA 4			294	677	240	113	353	155	15.8	10.5	235	20.6	20.6
MAGNIFICA 5m	MAGNIFICA 5			294	677	240	113	353	155	15.8	10.5	235	23.3	23.3

BASEMENT (mm)

Stand for MAGNIFICA 1-2

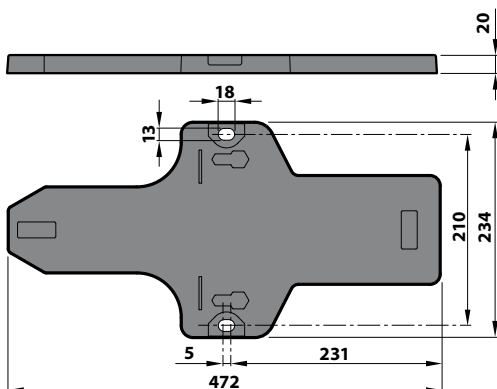

Stand for MAGNIFICA 3-4-5

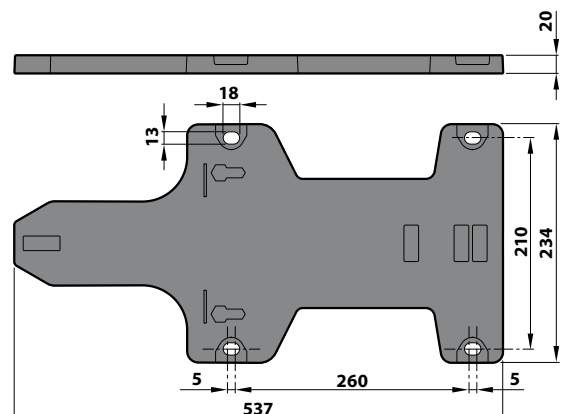

MATERIALS AND COMPONENTS

1 Pump body	Glass-fibre reinforced polypropylene with ISO 228/1 threaded ports			
2 Seal insert	Glass-fibre reinforced polypropylene			
3 Diffuser	Noryl™			
4 Impeller	Noryl™			
5 Mechanical seal	Water pump	Seal	Shaft	Materials
	MAGNIFICA 1-2	AR-17	Ø 17	Ceramic / Graphite / NBR
	MAGNIFICA 3-4-5	AR-20R	Ø 20	Ceramic / Graphite / NBR
6 Motor shaft	Stainless steel AISI 431			
7 Electric motor	MAGNIFICA m: single-phase 230 V - 50 Hz with winding integrated thermal motor protection MAGNIFICA: three-phase 230/400 V - 50 Hz ※ Pumps are equipped with high-efficiency motors (IEC 60034-30-1) class IE2 for single-phase models class IE3 for three-phase models Continuous running duty S1			
8 O-Ring (OR)	NBR			
9 Cover	Polycarbonate			
10 Pre-filter	Polypropylene			
11 Closing knob	Nylon			
12 Fittings	PVC-U			
13 Base	Polypropylene			



※ For pools up to
70 m³



- ※ Robust electric pumps constructed with high-quality components and thick materials for extended durability and quiet operation.
- ※ Pre-filter equipped with a transparent cover for easy visual inspection, featuring an extra-large filter basket to reduce cleaning frequency.

- ※ High resistance to heat, chemicals, and salt corrosion.
- ※ Motor case painted with cathaphoresis for added protection
- ※ Supplied with 1½" GAS threaded ISO 228/1 connection fittings and AISI 304 screws

PERFORMANCE RANGE

- Flow rate up to **310 l/min** (18.6 m³/h)
- Head up to **16 m**

INSTALLATION AND USE

Self-priming pump with a built-in filter, designed for water circulation in residential swimming pools up to **70 m³**.

APPLICATION LIMITS

- Manometric suction head up to **4 m** (HS)
- Liquid temperature up to **+40 °C**
- Ambient temperature up to **+40 °C**
- Maximum working pressure **2.5 bar**
- Swimming pool water (pH 6.5 8.4).

CURVES AND PERFORMANCE DATA – HS=0 m

50 Hz

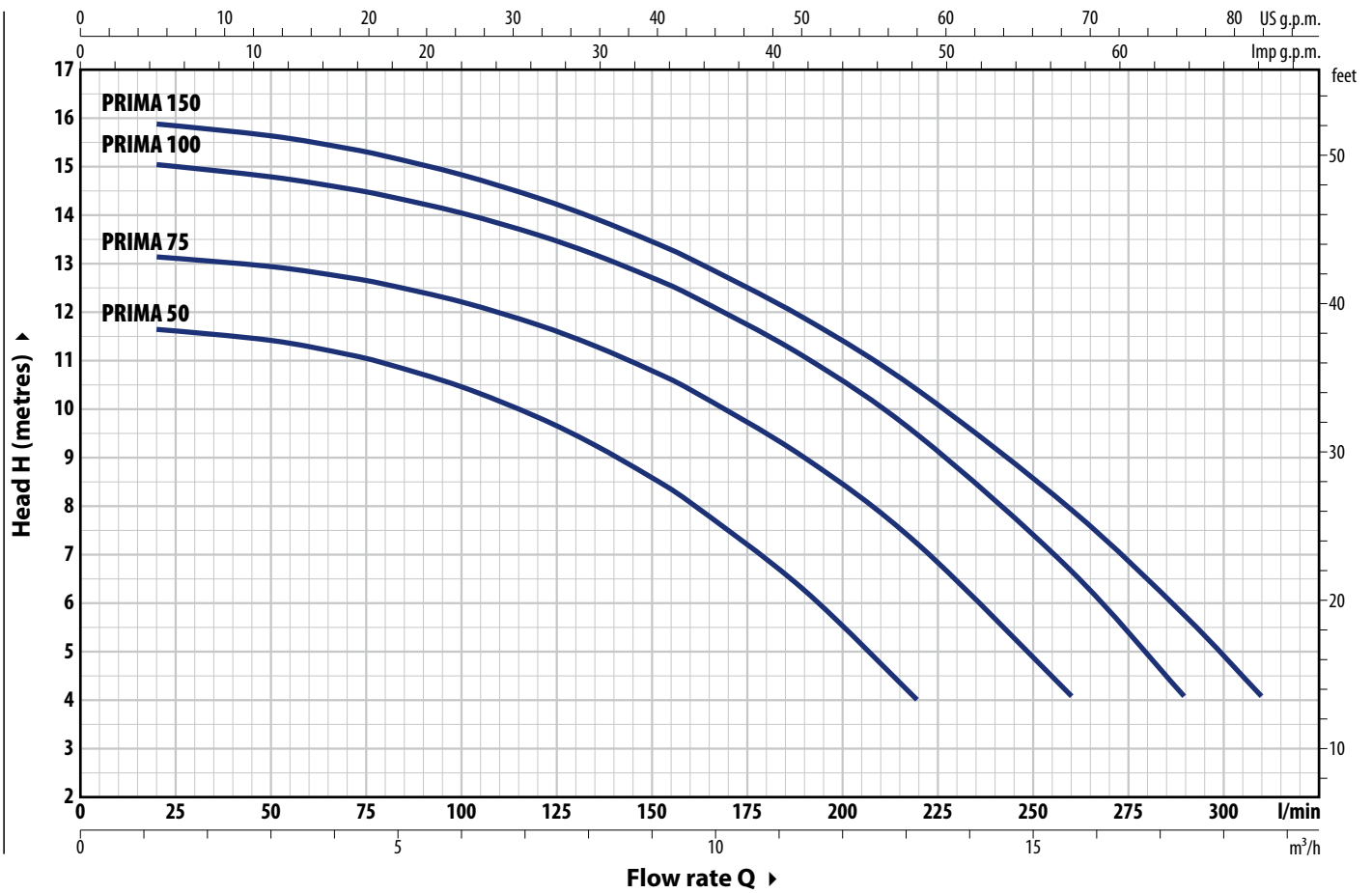

TYPE		POWER (P ₂)		1~3~	Q	m ³ /h																
Single-phase	Three-phase	kW	HP			0	1.2	3	4.2	4.8	6	7.2	9	9.6	11.4	13.2	15.6	17.4	18.6			
					0	20	50	70	80	100	120	150	160	190	220	260	290	310				
PRIMA 50m	PRIMA 50	0.37	0.50	IE2 IE3	11.7	11.6	11.4	11.1	10.9	10.4	9.8	8.6	8	6.3	4							
PRIMA 75m	PRIMA 75	0.55	0.75		13.2	13.1	13	12.7	12.6	12.2	11.7	10.8	10.4	9	7	4						
PRIMA 100m	PRIMA 100	0.75	1		15	15	14.8	14.5	14.4	14	13.6	12.7	12.3	11	9.4	6.6	4					
PRIMA 150m	PRIMA 150	1.1	1.5		16	15.8	15.6	15.3	15.2	14.8	14.3	13.4	13	11.8	10.3	8	5.7	4				

Q = Flow rate H = Total manometric head HS = Suction height

Performance curves comply with EN ISO 9906 Grade 3B tolerance limits.

ABSORPTION

TYPE	VOLTAGE
Single-phase	230 V
PRIMA 50m	3.0 A
PRIMA 75m	3.8 A
PRIMA 100m	4.8 A
PRIMA 150m	5.5 A

TYPE	VOLTAGE	
	230 V - Δ	400 V - 人
PRIMA 50	2.6 A	1.5 A
PRIMA 75	2.8 A	1.6 A
PRIMA 100	2.9 A	1.7 A
PRIMA 150	4.0 A	2.3 A

DIMENSIONS AND WEIGHT

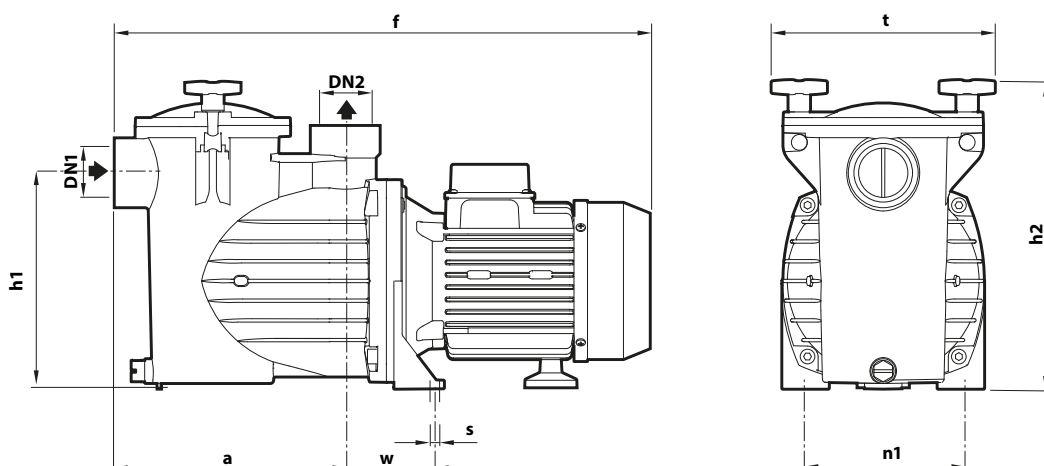

TYPE		PORTS		DIMENSIONS mm								kg	
Single-phase	Three-phase	DN1	DN2	a	f	h1	h2	n1	w	s	t	1~	3~
PRIMA 50m	PRIMA 50	1½"	1½"	205	476	191	275	140	68	9	197	8.8	8.8
PRIMA 75m	PRIMA 75											9.8	9.8
PRIMA 100m	PRIMA 100												
PRIMA 150m	PRIMA 150												

MATERIALS AND COMPONENTS

1 Pump body	Glass-fibre reinforced polypropylene		
2 Seal insert	Glass-fibre reinforced polypropylene		
3 Diffuser	Glass-fibre reinforced polypropylene		
4 Impeller	Noryl™		
5 Mechanical seal	Seal	Shaft	Materials
	AR-17	Ø 17	Graphite / Alumina Oxide / NBR
6 Motor shaft	Stainless steel AISI 316		
7 Electric motor	<p>PRIMA m: single-phase 230 V - 50 Hz with winding integrated thermal motor protection PRIMA: three-phase 230/400 V - 50 Hz</p> <p>※ Pumps are equipped with high-efficiency motors (IEC 60034-30-1) class IE3 for three-phase models</p> <ul style="list-style-type: none"> – Continuous running duty S1 – Insulation: CLASS F – Protection rating: IP 55 		
8 O-Ring (OR)	NBR		
9 Cover	Polycarbonate		
10 Pre-filter	Polypropylene		
11 Closing knob	Nylon		
12 Fittings	PVC		



※ For pools up to
135 m³



- ※ Robust electric pumps constructed with high-quality components and thick materials for extended durability and quiet operation.
- ※ Pre-filter equipped with a transparent cover for easy visual inspection, featuring an extra-large filter basket to reduce cleaning frequency.

- ※ High resistance to heat, chemicals, and salt corrosion.
- ※ Motor case painted with cathoporesis for added protection
- ※ Supplied with 2" GAS threaded ISO 228/1 connection fittings and AISI 304 screws

PERFORMANCE RANGE

- Flow rate up to **600 l/min** (36 m³/h)
- Head up to **21 m**

INSTALLATION AND USE

Self-priming pump with a built-in filter, designed for water circulation in residential swimming pools up to **135 m³**.

APPLICATION LIMITS

- Manometric suction head up to **4 m** (HS)
- Liquid temperature up to **+40 °C**
- Ambient temperature up to **+40 °C**
- Maximum working pressure **2.5 bar**
- Swimming pool water (pH 6.5 – 8.4).

AVAILABLE UPON REQUEST

- ※ Smooth connection fitting **63 mm**
- ※ Smooth connection fitting **2" BS**

Key to open the pre-filter cover included.



CURVES AND PERFORMANCE DATA – HS=0 m

50 Hz

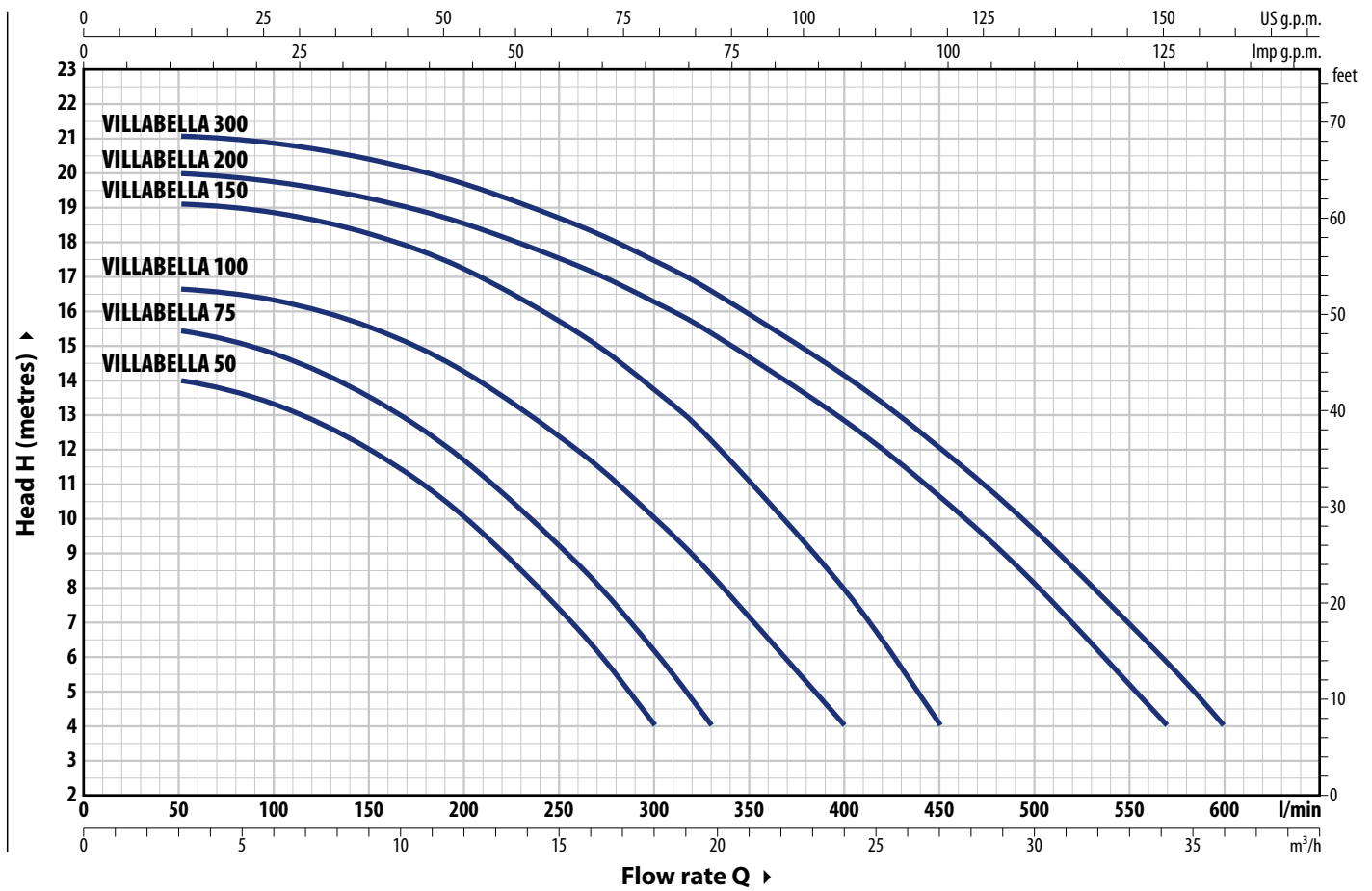

TYPE		POWER (P ₂)		1~ 3~	Q	m ³ /h												
Single-phase	Three-phase	kW	HP			0	3	6	9	12	15.6	18	19.8	24	27	34.2	36	
						0	50	100	150	200	260	300	330	400	450	570	600	
VILLABELLA 50m	VILLABELLA 50	0.37	0.50	IE2 IE3		14	14	13.3	12	10	6.8	4						
VILLABELLA 75m	VILLABELLA 75	0.55	0.75			15.5	15.5	14.8	13.5	11.7	8.7	6	4					
VILLABELLA 100m	VILLABELLA 100	0.75	1			16.5	16.4	16.3	15.6	14.2	12	10	8.3	4				
VILLABELLA 150m	VILLABELLA 150	1.1	1.5			19	18.9	18.8	18.2	17.2	15.3	13.7	12.2	8	4			
VILLABELLA 200m	VILLABELLA 200	1.5	2			20	19.9	19.8	19.3	18.5	17.3	16.3	15.4	12.8	10.6	4		
VILLABELLA 300m	VILLABELLA 300	2.2	3			21	20.9	20.8	20.4	19.7	18.5	17.4	16.6	14	12	5.8	4	

Q = Flow rate H = Total manometric head HS = Suction height

Performance curves comply with EN ISO 9906 Grade 3B tolerance limits.

ABSORPTION

TYPE	VOLTAGE
Single-phase	230 V
VILLABELLA 50m	4.2 A
VILLABELLA 75m	4.7 A
VILLABELLA 100m	6.0 A
VILLABELLA 150m	7.5 A
VILLABELLA 200m	9.5 A
VILLABELLA 300m	10.5 A

TYPE	VOLTAGE	
	230 V - Δ	400 V - ƿ
VILLABELLA 50	2.8 A	1.6 A
VILLABELLA 75	2.9 A	1.7 A
VILLABELLA 100	3.5 A	2.0 A
VILLABELLA 150	4.8 A	2.8 A
VILLABELLA 200	6.6 A	3.8 A
VILLABELLA 300	7.4 A	4.3 A

DIMENSIONS AND WEIGHT

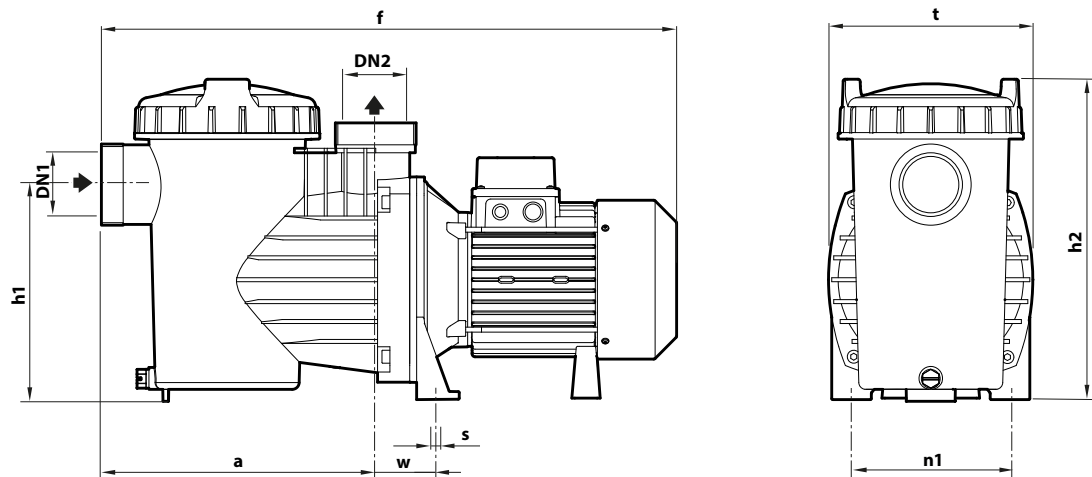

Single-phase	TYPE	Three-phase	PORTS		DIMENSIONS mm							kg		
			DN1	DN2	a	f	h1	h2	n1	w	s	t	1~	3~
VILLABELLA 50m	VILLABELLA 50		2"	2"	277	550	216	315	160	84	9	206	11.7	11.7
VILLABELLA 75m	VILLABELLA 75	11.5											11.5	
VILLABELLA 100m	VILLABELLA 100	12.9											12.9	
VILLABELLA 150m	VILLABELLA 150	13.9				13.9								
VILLABELLA 200m	VILLABELLA 200	14.9				14.9								
VILLABELLA 300m	VILLABELLA 300	17.4				17.4								

MATERIALS AND COMPONENTS

1 Pump body	Glass-fibre reinforced polypropylene		
2 Seal insert	Glass-fibre reinforced polypropylene		
3 Diffuser	Glass-fibre reinforced polypropylene		
4 Impeller	Noryl™		
5 Mechanical seal	Seal	Shaft	Materials
	AR-15	Ø 15	Graphite / Alumina Oxide / NBR
6 Motor shaft	Stainless steel AISI 316		
7 Electric motor	VILLABELLA m: single-phase 230 V - 50 Hz with winding integrated thermal motor protection VILLABELLA: three-phase 230/400 V - 50 Hz ※ Pumps are equipped with high-efficiency motors (IEC 60034-30-1) class IE3 for three-phase models – Continuous running duty S1 – Insulation: CLASS F – Protection rating: IP 55		
8 O-Ring (OR)	NBR		
9 Cover	Polycarbonate		
10 Pre-filter	Polypropylene		
11 Fittings	PVC		



※ For pools up to
1080 m³



- ※ Robust electric pumps constructed with high-quality components and thick materials for extended durability and quiet operation.
- ※ Pre-filter equipped with a transparent cover for easy visual inspection, featuring an extra-large filter basket to reduce cleaning frequency.

- ※ Special anti-corrosion plastic base that provides stable support for the pump and piping.
- ※ High resistance to heat, chemicals, and salt corrosion.
- ※ Motor case with cathodolysis treatment
- ※ AISI 316 screws

PERFORMANCE RANGE

- Flow rate up to **2400 l/min** (180 m³/h)
- Head up to **16 m**

INSTALLATION AND USE

Self-priming pump with a built-in filter, designed for water circulation in residential swimming pools up to **1080 m³** in size.

APPLICATION LIMITS

- Manometric suction head up to **4 m** (HS)
- Liquid temperature up to **+40 °C**
- Ambient temperature up to **+40 °C**
- Maximum working pressure **2.5 bar**
- Swimming pool water (pH 6.5 – 8.4).

AVAILABLE UPON REQUEST

- ※ Bronze impeller

CURVES AND PERFORMANCE DATA – HS=0 m

50 Hz - n= 1450 min⁻¹

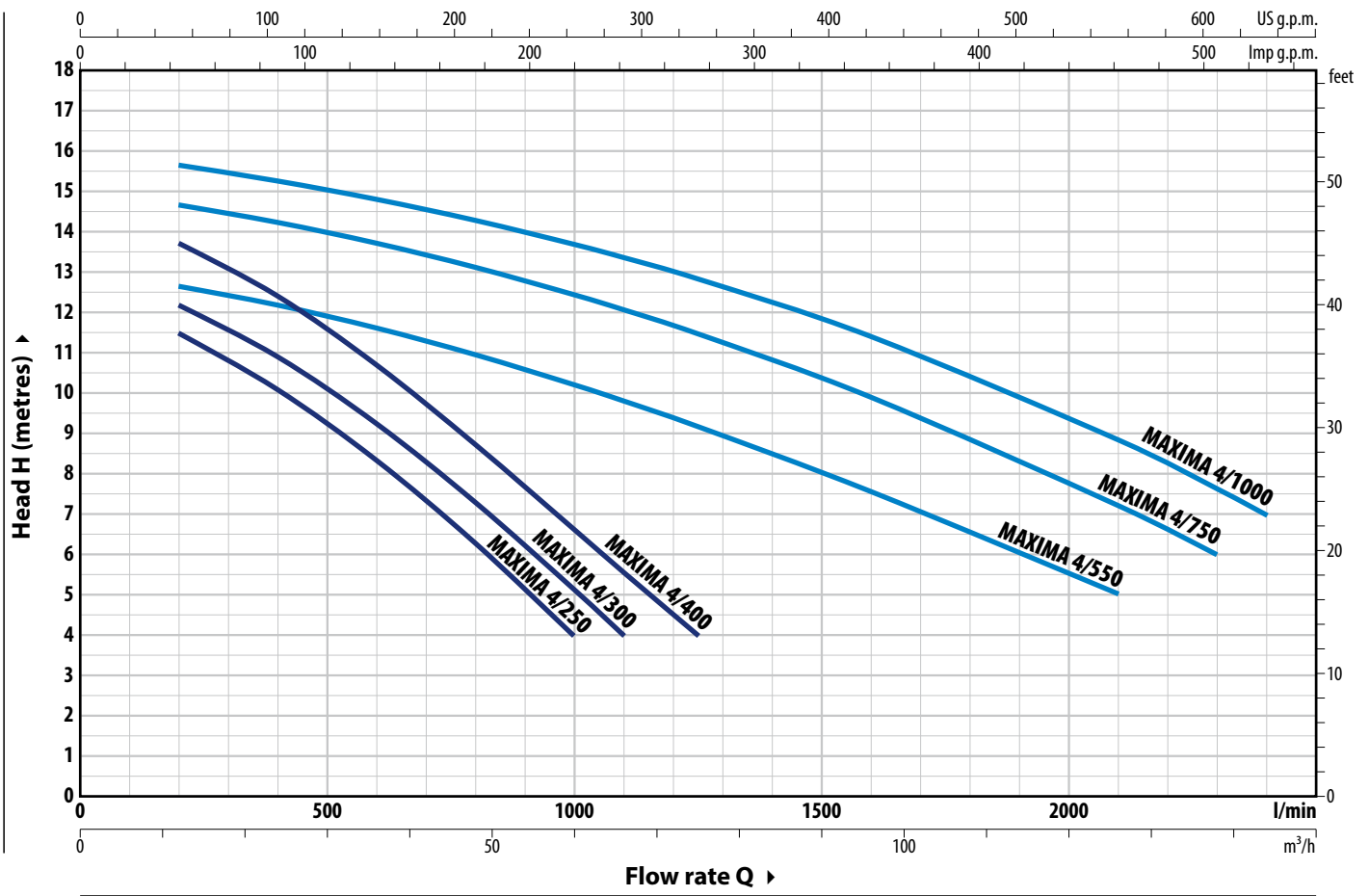

TYPE	POWER (P ₂)		3~	Q	H metres														
	kW	HP			m ³ /h	0	12	36	48	60	66	75	96	126	138	144			
Three-phase				l/min	0	200	600	800	1000	1100	1250	1600	2100	2300	2400				
MAXIMA 4/250	1.8	2.5	IE3	H metres	12.5	11.5	8.4	6.3	4										
MAXIMA 4/300	2.2	3			13	12	9.2	7.3	5	4									
MAXIMA 4/400	3	4			14.5	13.5	10.7	8.7	6.6	5.6	4								
MAXIMA 4/550	4	5.5			13	12.5	11.6	11	10.2	9.8	9	7.5	5						
MAXIMA 4/750	5.5	7.5			15	14.5	13.7	13	12.4	12	11.5	10	7.2	6					
MAXIMA 4/1000	7.5	10			16	15.5	14.8	14.3	13.7	13.4	12.8	11.4	8.8	7.6	7				

Q = Flow rate H = Total manometric head HS = Suction height

Performance curves comply with EN ISO 9906 Grade 3B tolerance limits.

ABSORPTION

TYPE	VOLTAGE			
	230 V - Δ	400 V - Δ	400 V - Δ	690 V - Δ
MAXIMA 4/250	8.1 A	4.7 A	-	-
MAXIMA 4/300	7.8 A	4.5 A	-	-
MAXIMA 4/400	11.2 A	6.5 A	-	-
MAXIMA 4/550	15.6 A	9.0 A	-	-
MAXIMA 4/750	-	-	12.5 A	7.2 A
MAXIMA 4/1000	-	-	14.5 A	8.4 A

DIMENSIONS AND WEIGHT

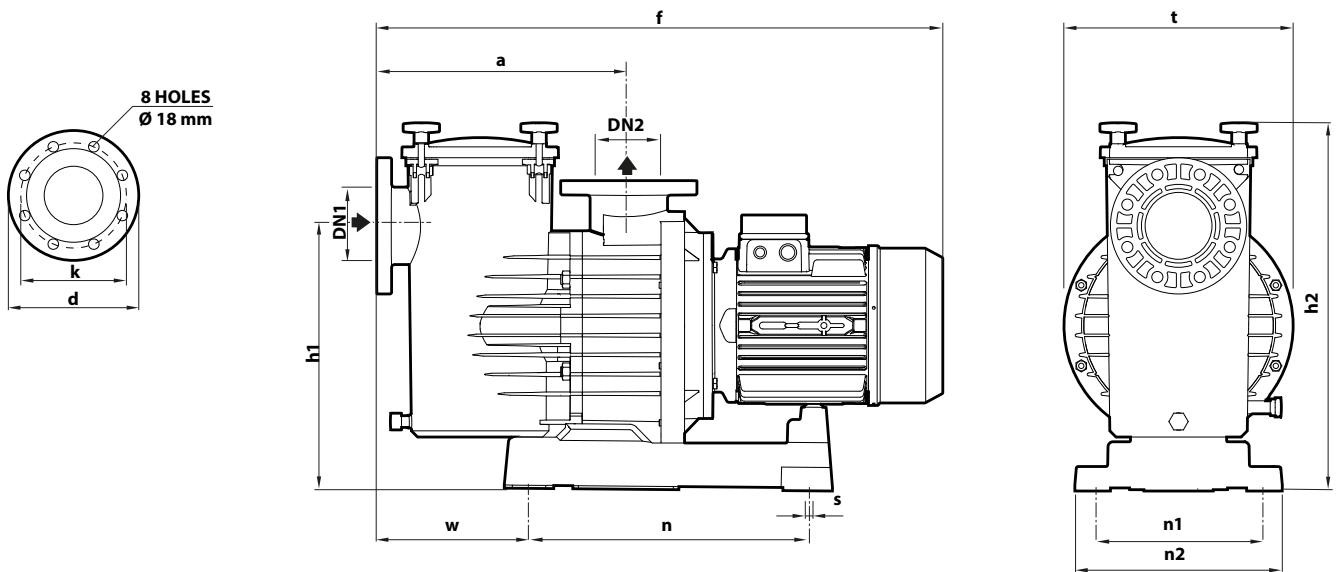

TYPE	PORTS		DIMENSIONS mm												kg
	DN1	DN2	a	f	h1	h2	n	n1	n2	s	t	w	d	k	
MAXIMA 4/250	110	110	407	838	425	596	450	300	335	11	368	246	218	180	42.0
MAXIMA 4/300															42.5
MAXIMA 4/400															44.5
MAXIMA 4/550															53.4
MAXIMA 4/750															66.0
MAXIMA 4/1000															76.0

MATERIALS AND COMPONENTS

1 Pump body	Glass-fibre reinforced polypropylene		
2 Seal insert	Glass-fibre reinforced polypropylene		
3 Diffuser	Glass-fibre reinforced polypropylene		
4 Impeller	Noryl™		
5 Mechanical seal	Seal	Shaft	Materials
	AR-30	Ø 30	Graphite / Alumina Oxide / NBR
6 Motor shaft	Stainless steel AISI 316		
7 Electric motor	MAXIMA: three-phase 230/400 V - 50 Hz up to 4 kW 400/690 V - 50 Hz 5.5 to 7.5 kW – Continuous running duty S1 – Insulation: CLASS F – Protection rating: IP 55		
8 O-Ring (OR)	NBR		
9 Cover	Polycarbonate		
10 Pre-filter	Polypropylene		
11 Closing knob	Nylon		
12 Base	Noryl™		

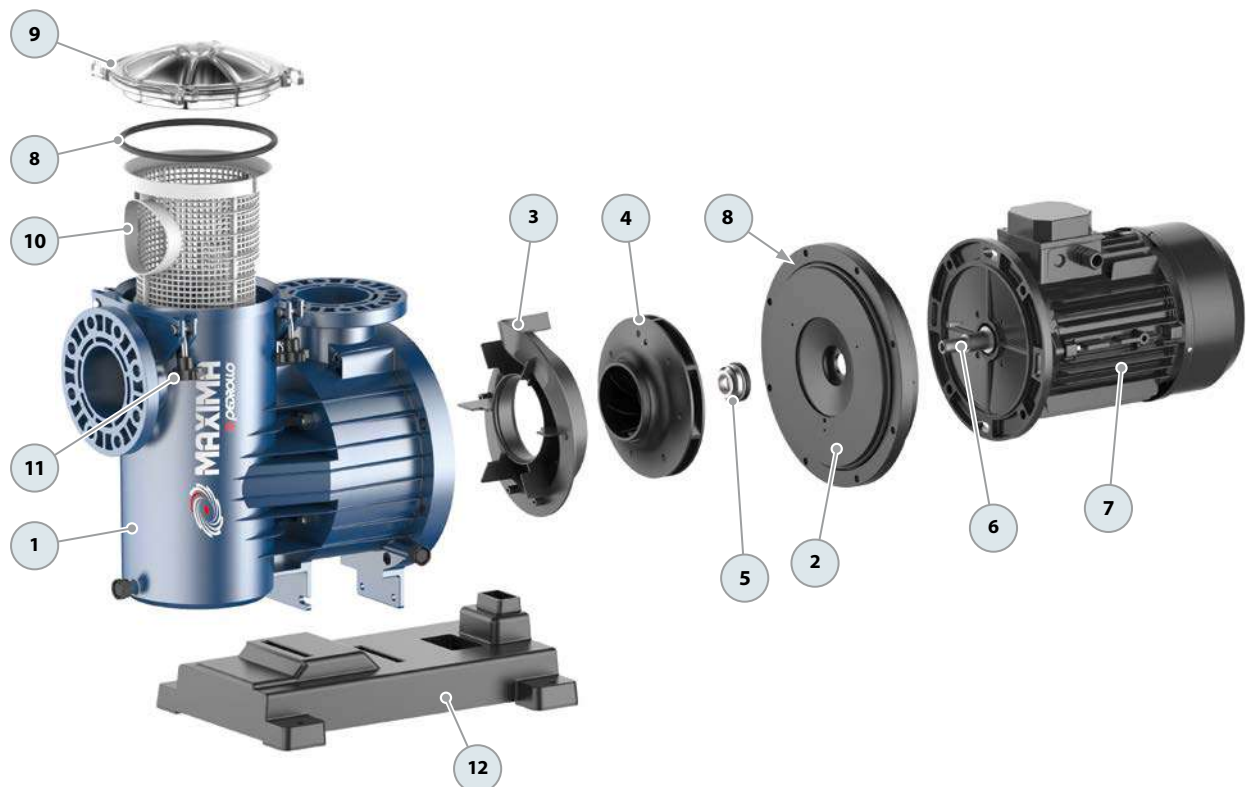

-  Clean water
-  Domestic use
-  Civil use



PERFORMANCE RANGE

- Flow rate up to **300 l/min** (18.0 m³/h)
- Head up to **25.5 m**

INSTALLATION AND USE

SPRINKLER, a versatile self-priming pump designed to effortlessly draw water, even when air is present in the liquid.

With its reliable performance and user-friendly operation, **SPRINKLER** is ideal for various applications, including domestic, civil, and irrigation.

ELECTRIC MOTOR

The three-phase pumps are equipped with newly developed electric motors designed to work with inverters, which guarantee stable and quiet operation.

Efficiency class **IE3** for three-phase motors and **IE2** for single-phase motors, with class F insulation and IPX4 protection

APPLICATION LIMITS

- Manometric suction head up to **9 m (HS)**
- Liquid temperature between **-10 °C** and **+40 °C**
- Ambient temperature up to **+40 °C**
- Maximum working pressure **10 bar**

AVAILABLE UPON REQUEST

- ✘ IPX5 protection
- ✘ Other voltage and frequency 60 Hz

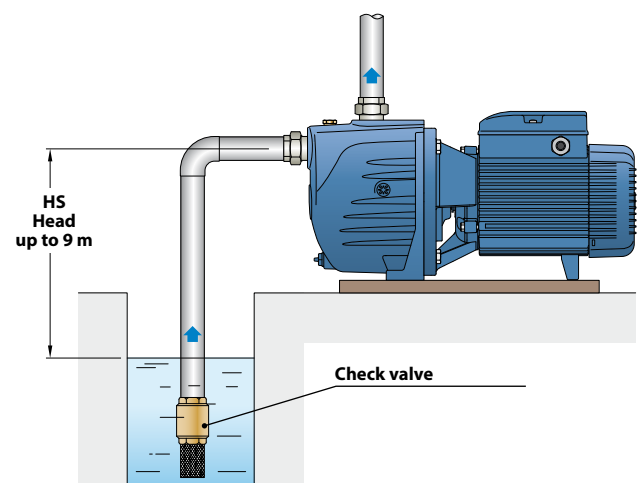

CURVES AND PERFORMANCE DATA – HS=0 m

50 Hz

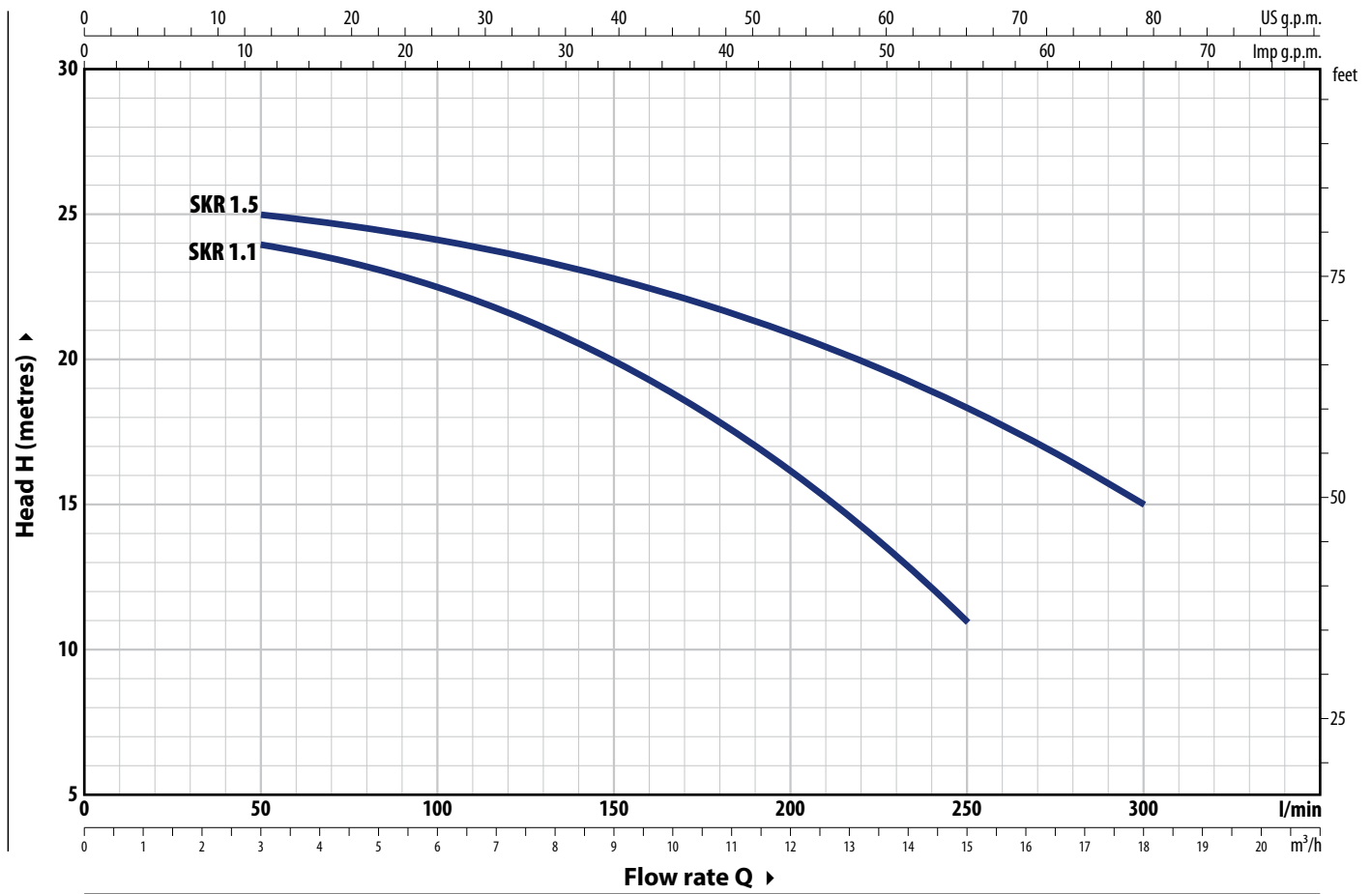

TYPE		POWER (P ₂)		1~	3~	Q	m ³ /h						
Single-ph.	Three-ph.	kW	HP				0	3	6	9	12	15	18
SKRm 1.1	SKR 1.1	1.1	1.5	IE2	IE3	H metres	0	50	100	150	200	250	300
SKRm 1.5	SKR 1.5	1.5	2				24.5	24	22.5	20	16.3	11	
							25.5	25	24	22.7	20.8	18.2	15

Q = Flow rate H = Total manometric head HS = Suction height

Performance curves comply with EN ISO 9906 Grade 3B tolerance limits.



ABSORPTION

TYPE	VOLTAGE
Single-ph.	230 V
SKRm 1.1	7.5 A
SKRm 1.5	10.3 A

TYPE	VOLTAGE	
	230 V - Δ	400 V - 人
SKR 1.1	5.0 A	2.9 A
SKR 1.5	6.7 A	3.9 A

DIMENSIONS AND WEIGHT

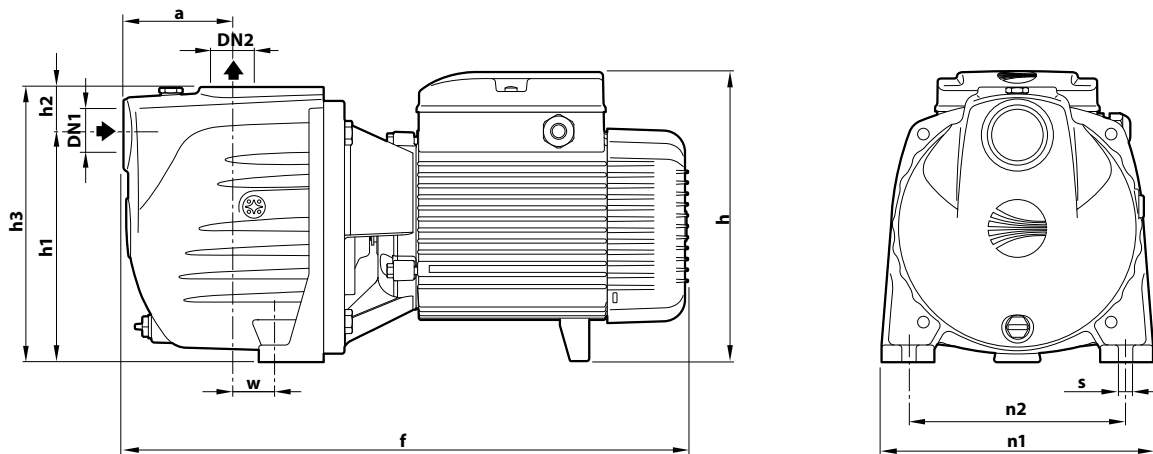

TYPE		PORTS		DIMENSIONS mm										kg	
Single-ph.	Three-ph.	DN1	DN2	a	f	h	h1	h2	h3	n1	n2	w	s	1~	3~
SKRm 1.1	SKR 1.1	1½"	1½"	91	465	241	186	39	225	223	178	37.5	11	24.5	24.5
SKRm 1.5	SKR 1.5													25.8	25.8

PALLET CAPACITY

TYPE		NO. OF PUMPS
Single-ph.	Three-ph.	
SKRm 1.1	SKR 1.1	35
SKRm 1.5	SKR 1.5	35

MATERIALS AND COMPONENTS

1 Pump body	Cast iron with cathaphoresis treatment, provided with ISO 228/1 threaded ports		
2 Cover	Cast iron with cathaphoresis treatment		
3 Diffuser	Noryl™		
4 Impeller	Noryl™		
5 Mechanical seal	Seal FN-18	Shaft Ø 18 mm	Materials Graphite / Ceramic / NBR
6 Motor shaft	Stainless steel AISI 431		
7 Electric motor	<p>SKRm: single-phase 230 V - 50 Hz with winding integrated thermal motor protection</p> <p>SKR: three-phase 230/400 V - 50 Hz</p> <p>※ Pumps are equipped with high-efficiency motors (IEC 60034-30-1)</p> <p>class IE2 for single-phase models</p> <p>class IE3 for three-phase models</p> <p>Continuous running duty S1</p>		

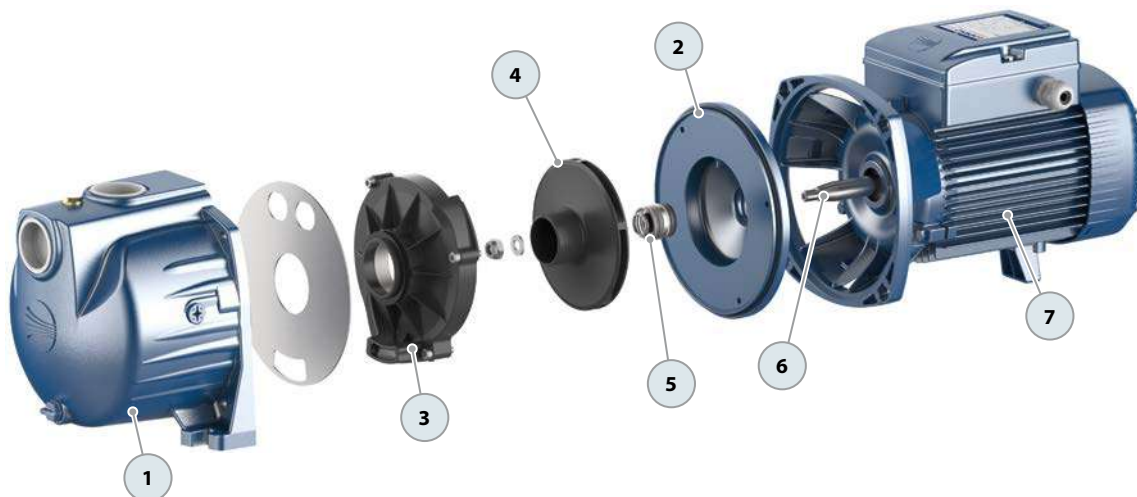



※ VERSATILE

PLURIJET pumps are designed to handle any domestic water task with ease. With exceptional suction capacity, they can prime up to 9 metres deep, making them perfect for any household water requirement.

※ EFFICIENT

Get the job done efficiently with PLURIJET pumps. Their high hydraulic efficiency means they consume significantly less electricity compared to self-priming JET pumps, ensuring you have all the water you need without draining your power supply.

※ RELIABLE

Stainless steel components that you can count on for reliability and durability.

※ SILENT

Featuring multi-cellular hydraulics for maximum pressure with minimal power consumption, these pumps are significantly quieter, with noise levels between 48 and 54 dBA.

PERFORMANCE RANGE

- Flow rate up to **130 l/min** (7.8 m³/h)
- Head up to **52 m**

INSTALLATION AND USE

PLURIJET self-priming pumps are designed to transfer clean water free from abrasive particles and liquids that will not damage the pump's components. They are suitable for both domestic and civil applications, particularly for water distribution along pressure tanks to increase overall network pressure, rainwater recovery, and irrigation.

ELECTRIC MOTOR

Three-phase pumps are equipped with high-efficiency motors (IEC 60034-30-1).

Efficiency class **IE3** for three-phase motors and **IE2** for single-phase motors, with class F insulation and IPX4 protection.

APPLICATION LIMITS

- Manometric suction head up to **9 m** (HS)
- Liquid temperature between **-10 °C** and **+60 °C**
- Ambient temperature up to **+40 °C**
- Maximum working pressure **6 bar**

AVAILABLE UPON REQUEST

- ※ Technopolymer impeller (cost-effective version)
- ※ Different voltage requirements 60 Hz frequency

PATENTS - TRADE MARKS - MODELS

- PLURIJET® Registered trademark No. 3974301
- Patent Pending No. 102023000019836

CURVES AND PERFORMANCE DATA – HS=0 m

50 Hz

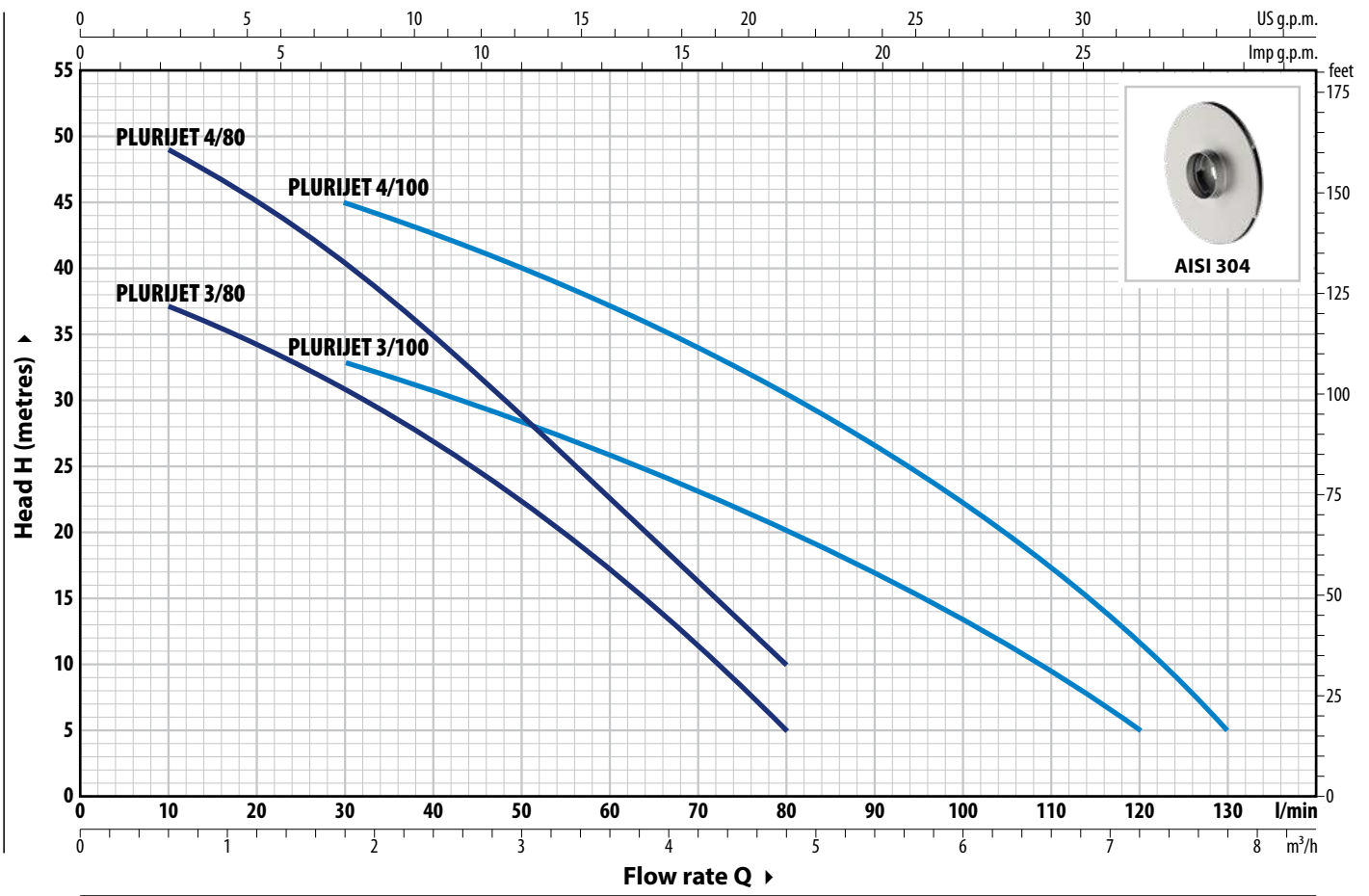

TYPE	Single-phase	Three-phase	POWER (P ₂)		1~3~	Q	Flow rate																	
			kW	HP			m³/h	0	0.3	0.6	1.2	1.8	2.4	3.0	3.6	4.2	4.8	5.4	6.0	6.6	7.2	7.8		
							l/min	0	5	10	20	30	40	50	60	70	80	90	100	110	120	130		
PLURIJETm 3/80		PLURIJET 3/80	0.48	0.65	IE2 IE3	H metres		40	38	37	34.5	31	27	22.5	17	11	5							
PLURIJETm 4/80		PLURIJET 4/80	0.55	0.75				52	50	49	44.5	40	34	28.5	22.5	16	10							
PLURIJETm 3/100		PLURIJET 3/100	0.55	0.75				38	37	36	34.5	33	31	28	26	23	20	17	13.5	10	5			
PLURIJETm 4/100		PLURIJET 4/100	0.75	1				50	50	49	47	45	42	39.5	37	34	30.5	26.5	22	17	11	5		

Q = Flow rate H = Total manometric head HS = Suction height

Performance curves comply with EN ISO 9906 Grade 3B tolerance limits.

EXAMPLE OF INSTALLATION

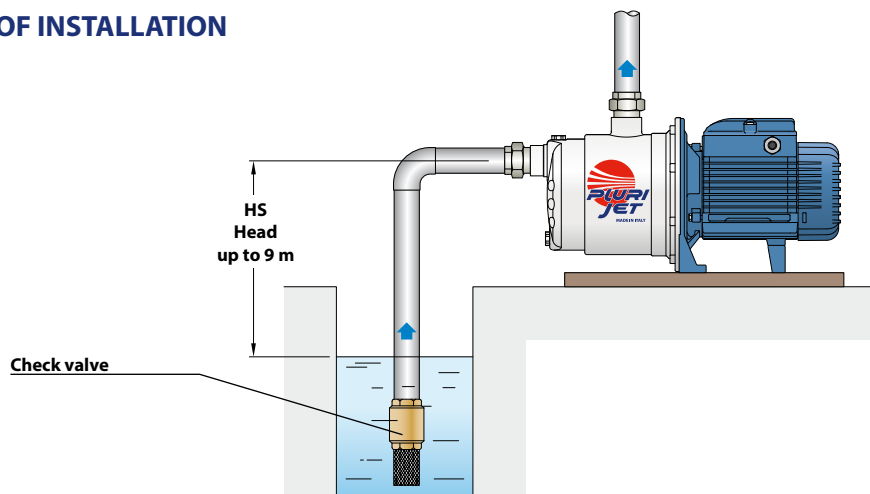

ABSORPTION

TYPE	VOLTAGE
Single-phase	230 V
PLURIJETm 3/80	3.2 A
PLURIJETm 4/80	3.9 A
PLURIJETm 3/100	4.1 A
PLURIJETm 4/100	5.8 A

TYPE	VOLTAGE	
	230 V - Δ	400 V - 人
PLURIJET 3/80	2.6 A	1.5 A
PLURIJET 4/80	3.5 A	2.0 A
PLURIJET 3/100	3.5 A	2.0 A
PLURIJET 4/100	4.0 A	2.3 A

DIMENSIONS AND WEIGHT

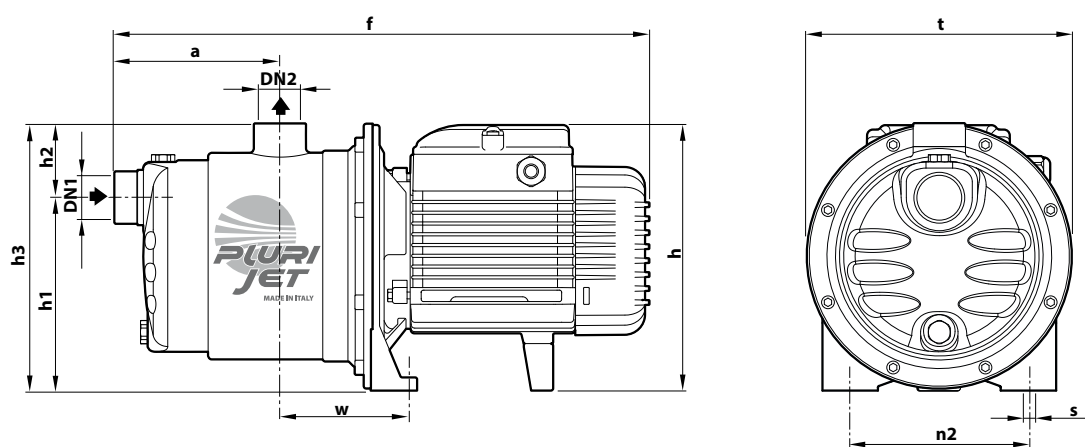

TYPE	PORTS	DIMENSIONS mm											kg		
		DN1	DN2	a	f	h	h1	h2	h3	t	n2	w	s	1~	3~
Single-phase	Three-phase														
PLURIJETm 3/80	PLURIJET 3/80	1"	1"	113	367	182	132	51	183	182	120	87	9	7.8	7.8
PLURIJETm 4/80	PLURIJET 4/80			138	392									9.1	8.4
PLURIJETm 3/100	PLURIJET 3/100			113	367									8.6	7.9
PLURIJETm 4/100	PLURIJET 4/100			138	410	202 *								10	11.6

(*) h=221 mm for single-phase 110 V versions

PALLET CAPACITY

TYPE	NO. OF PUMPS
Single-phase	
PLURIJETm 3/80	84
PLURIJETm 4/80	72
PLURIJETm 3/100	84
PLURIJETm 4/100	72

MATERIALS AND COMPONENTS

1 Pump body	Stainless steel AISI 304 , provided with ISO 228/1 threaded ports		
2 Cover	Stainless steel AISI 304		
3 Impellers	Stainless steel AISI 304		
4 Diffusers	Noryl™ complete with wear rings		
5 Mechanical seal	Seal AR-13	Shaft Ø 13 mm	Materials Ceramic / Graphite / NBR
6 Motor shaft	Stainless steel AISI 431		
7 Electric motor	<p>PLURIJETm: single-phase 230 V - 50 Hz with winding integrated thermal motor protection</p> <p>PLURIJET: three-phase 230/400 V - 50 Hz</p> <p>※ Pumps are equipped with high-efficiency motors (IEC 60034-30-1)</p> <p>class IE2 for single-phase models</p> <p>class IE3 for three-phase models</p> <p>Continuous running duty S1</p>		

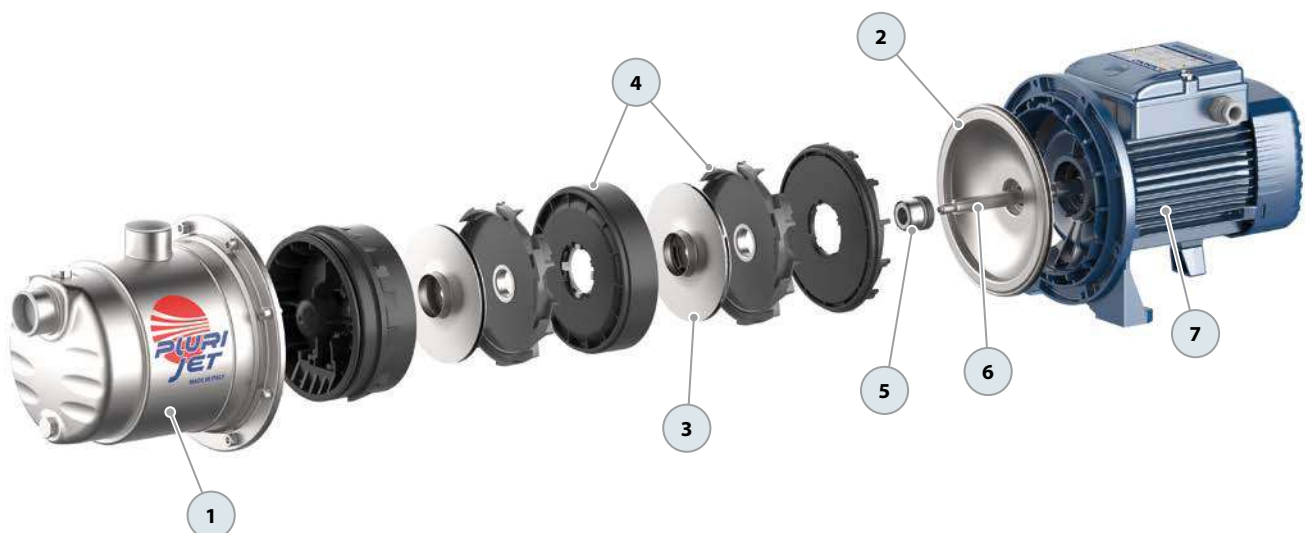



※ **PLURIJET high-efficiency pumps with stainless steel impellers are as essential as water. Thanks to their reliability, quiet operation, and cost-effectiveness, they provide the best and most effective solution for your domestic needs.**

※ **VERSATILE**

PLURIJET pumps are designed to handle any domestic water task with ease. With exceptional suction capacity, they can prime up to 9 metres deep, making them perfect for any household water requirement.

※ **EFFICIENT**

Get the job done efficiently with PLURIJET pumps. Their high hydraulic efficiency means they consume significantly less electricity compared to self-priming JET pumps, en-

suring you have all the water you need without draining your power supply.

※ **SILENT**

Featuring multi-cellular hydraulics for maximum pressure with minimal power consumption, these pumps operate with significantly reduced noise levels, ensuring a quiet performance.

PERFORMANCE RANGE

- Flow rate up to **130 l/min** (7.8 m³/h)
- Head up to **52 m**

INSTALLATION AND USE

Designed to transfer clean water free from abrasive particles and safe liquids that will not damage any of the pump's components. Highly reliable and quiet, they are suitable for domestic applications.

They work seamlessly with small to medium-sized pressure tanks, offering an ideal setup for all irrigation requirements.

ELECTRIC MOTOR

The three-phase pumps are equipped with newly developed electric motors designed to work with inverters, which guarantee stable and quiet operation.

Efficiency class **IE3** for three-phase motors and **IE2** for single-phase motors, with class F insulation and IPX4 protection.

APPLICATION LIMITS

- Manometric suction head up to **9 m** (HS)
- Liquid temperature between **-10 °C** and **+60 °C**
- Ambient temperature up to **+40 °C**
- Maximum working pressure **6 bar**

AVAILABLE UPON REQUEST

- ※ Mechanical seal options available
- ※ Different voltage requirements 60 Hz frequency

PATENTS - TRADE MARKS - MODELS

- **PLURIJET**®Registered trademark No. 3974301
- Patent Pending No. 102023000019836

CURVES AND PERFORMANCE DATA – HS=0 m

50 Hz

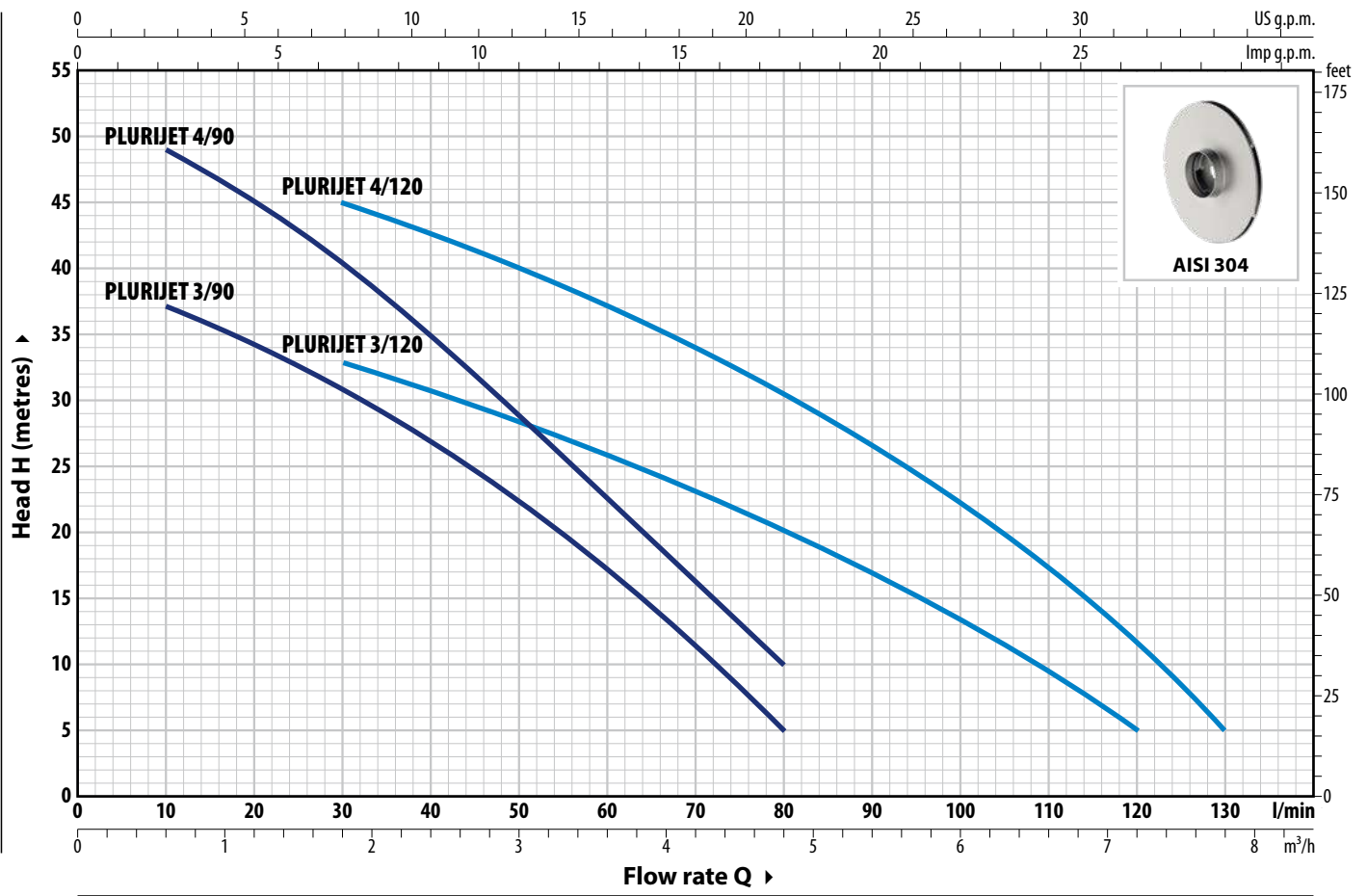

TYPE		POWER (P ₂)		1~3~	Q	m ³ /h																	
Single-phase	Three-phase	kW	HP			0	0.3	0.6	1.2	1.8	2.4	3.0	3.6	4.2	4.8	5.4	6.0	6.6	7.2	7.8			
						0	5	10	20	30	40	50	60	70	80	90	100	110	120	130			
PLURIJETm 3/90	PLURIJET 3/90	0.48	0.65	IE2 IE3	H metres	40	38	37	34.5	31	27	22.5	17	11	5								
PLURIJETm 4/90	PLURIJET 4/90	0.55	0.75			52	50	49	44.5	40	34	28.5	22.5	16	10								
PLURIJETm 3/120	PLURIJET 3/120	0.55	0.75			38	37	36	34.5	33	31	28	26	23	20	17	13.5	10	5				
PLURIJETm 4/120	PLURIJET 4/120	0.75	1			50	50	49	47	45	42	39.5	37	34	30.5	26.5	22	17	11	5			

Q = Flow rate H = Total manometric head HS = Suction height

Performance curves comply with EN ISO 9906 Grade 3B tolerance limits.

EXAMPLE OF INSTALLATION

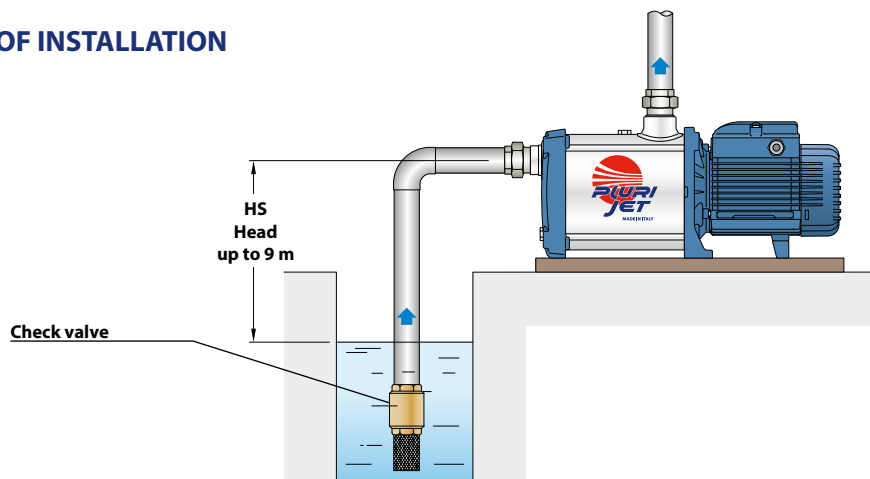

ABSORPTION

TYPE	VOLTAGE
Single-phase	230 V
PLURIJETm 3/90	3.2 A
PLURIJETm 4/90	3.9 A
PLURIJETm 3/120	3.9 A
PLURIJETm 4/120	5.8 A

TYPE	VOLTAGE	
	230 V - Δ	400 V - ㄩ
PLURIJET 3/90	2.2 A	1.3 A
PLURIJET 4/90	2.9 A	1.7 A
PLURIJET 3/120	2.9 A	1.7 A
PLURIJET 4/120	4.0 A	2.3 A

DIMENSIONS AND WEIGHT

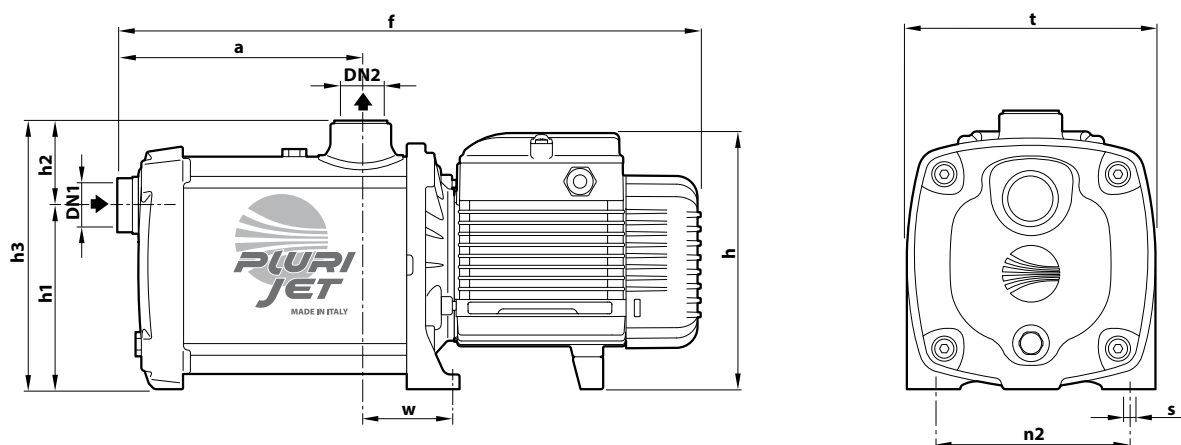

TYPE		PORTS		DIMENSIONS mm										kg	
Single-phase	Three-phase	DN1	DN2	a	f	h	h1	h2	h3	t	n2	w	s	1~	3~
PLURIJETm 3/90	PLURIJET 3/90	1"	1"	132	358	171	122	56	178	160	125	56.5	9	8.4	8.4
PLURIJETm 4/90	PLURIJET 4/90			157	383									9.7	9.0
PLURIJETm 3/120	PLURIJET 3/120			132	358	9.2								8.5	
PLURIJETm 4/120	PLURIJET 4/120			157	402	189								12.2	12.2

(*) h=221 mm for single-phase 110 V versions

MATERIALS AND COMPONENTS

1 Pump body	Stainless steel AISI 304 , provided with ISO 228/1 threaded ports		
2 Cover	Stainless steel AISI 304		
3 Impellers	Stainless steel AISI 304		
4 Diffusers	Noryl™ complete with wear rings		
5 Mechanical seal	Seal	Shaft	Materials
	AR-13	Ø 13 mm	Ceramic / Graphite / NBR
6 Motor shaft	Stainless steel AISI 431		
7 Electric motor	<p>PLURIJETm: single-phase 230 V - 50 Hz with winding integrated thermal motor protection</p> <p>PLURIJET: three-phase 230/400 V - 50 Hz</p> <p>※ Pumps are equipped with high-efficiency motors (IEC 60034-30-1)</p> <p>class IE2 for single-phase models</p> <p>class IE3 for three-phase models</p> <p>Continuous running duty S1</p>		

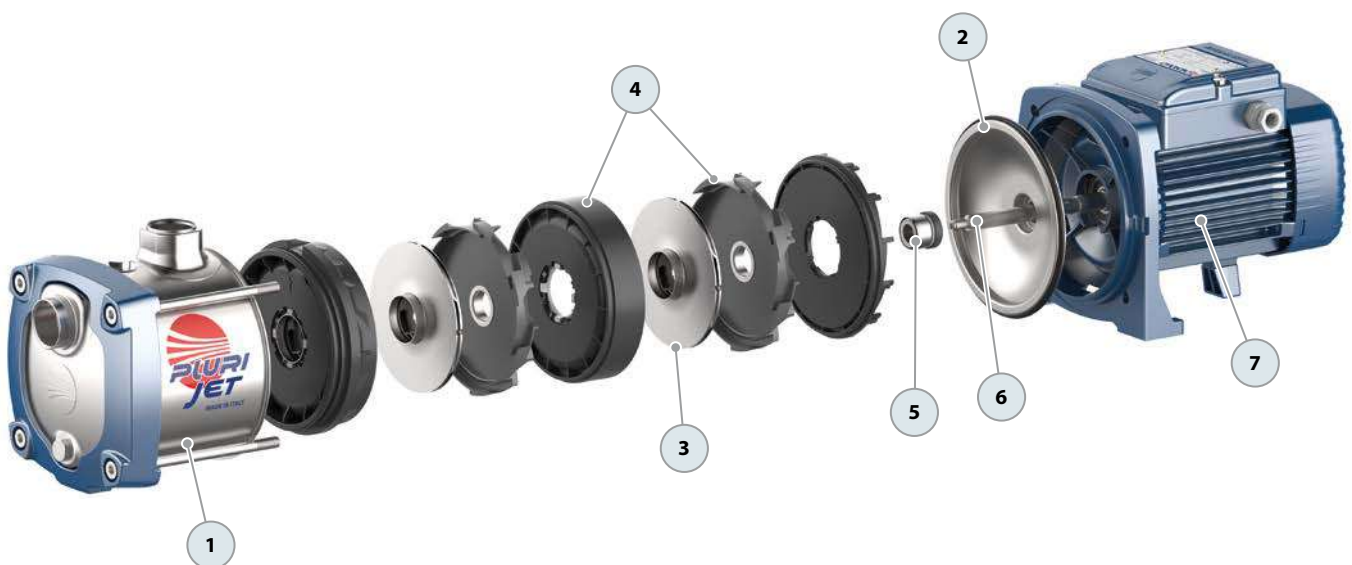

-  Clean water
-  Domestic use
-  Civil use



※ **PLURIJET high-efficiency pumps with stainless steel impellers are as essential as water. Thanks to their reliability, quiet operation, and cost-effectiveness, they provide the best and most effective solution for your domestic needs.**

PERFORMANCE RANGE

- Flow rate up to **200 l/min** (12 m³/h)
- Head up to **97 m**

INSTALLATION AND USE

PLURIJET self-priming pumps are designed to draw water and liquids that contain air, and clean water and liquids that will not damage the pump's components. Reliable and energy-efficient, they are suitable for both domestic and civil applications, particularly for water distribution along pressure tanks to increase overall network pressure, rainwater recovery, and irrigation.

ELECTRIC MOTOR

The three-phase pumps are equipped with newly developed electric motors designed to work with inverters, which guarantee stable and quiet operation.

Efficiency class **IE3** for three-phase motors and **IE2** for single-phase motors, with class F insulation and IPX4 protection.

APPLICATION LIMITS

- Manometric suction head up to **9 m** (HS)
- Liquid temperature between **-10 °C** and **+40 °C**
- Ambient temperature up to **+40 °C**
- Maximum working pressure **10 bar**

AVAILABLE UPON REQUEST

- ※ Technopolymer impeller (cost-effective version)
- ※ Different voltage requirements 60 Hz frequency
- ※ IPX5 protection
- ※ Certified pumps 

PATENTS - TRADE MARKS - MODELS

- PLURIJET® Registered trademark No. 3974301
- Patent Pending No. 102023000019836

CURVES AND PERFORMANCE DATA – HS=0 m

50 Hz

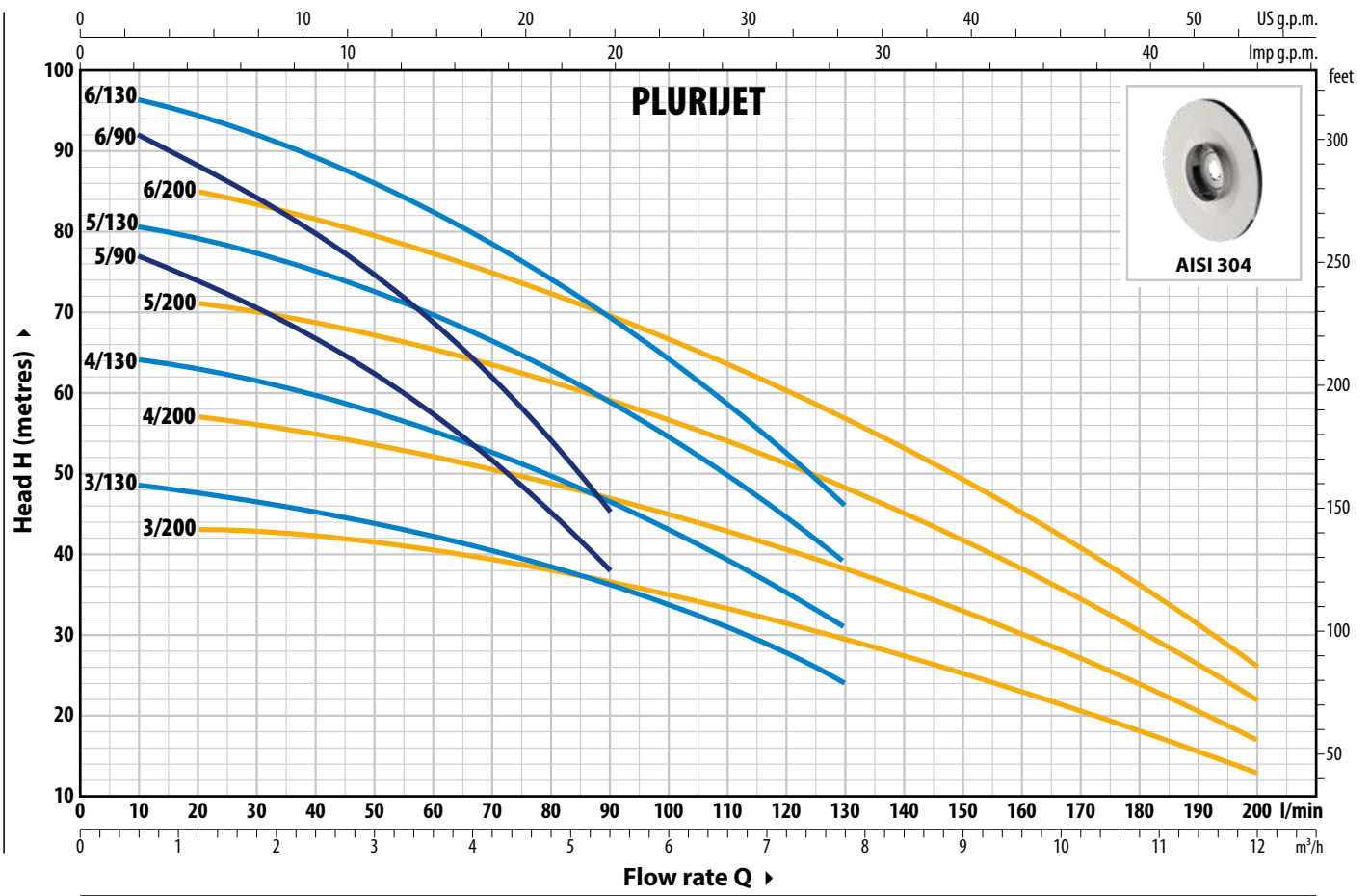

TYPE		POWER (P ₂)		1~3~	Q	m ³ /h														
Single-phase	Three-phase	kW	HP			0	0.3	0.6	1.2	2.4	3.6	5.4	6.0	7.8	8.4	9.6	10.8	12.0		
						0	5	10	20	40	60	90	100	130	140	160	180	200		
PLURIJETm 5/90	PLURIJET 5/90	1.1	1.5	IE2 IE3	H metres	80	78	77	74	67	57	38								
PLURIJETm 6/90	PLURIJET 6/90	1.5	2			96	94	92	88	80	69	45								
PLURIJETm 3/130	PLURIJET 3/130	1.1	1.5			49	49	48.5	47.5	45	42.5	36	33.5	24						
PLURIJETm 4/130	PLURIJET 4/130	1.5	2			65	65	64	63	60	56	46	43	31						
PLURIJETm 5/130	PLURIJET 5/130	1.8	2.5			81	81	80.5	79	75	70	59	54	39						
-	PLURIJET 6/130	2.2	3			97	97	96.5	94.5	90	83	69	64	46						
PLURIJETm 3/200	PLURIJET 3/200	1.1	1.5			44	43.5	43.5	43	42	40.5	37	35	29	27.5	23	18	13		
PLURIJETm 4/200	PLURIJET 4/200	1.5	2			58	57.5	57.5	57	55	52.5	47	45	38	35.5	30	24	17		
PLURIJETm 5/200	PLURIJET 5/200	1.8	2.5			73	72	71.5	71	69	65.5	59	56.5	48	44.5	38	30	22		
-	PLURIJET 6/200	2.2	3			87	86	85.5	85	82	78	69	67	57	53	45	36	26		

Q = Flow rate H = Total manometric head HS = Suction height

Performance curves comply with EN ISO 9906 Grade 3B tolerance limits.

EXAMPLE OF INSTALLATION

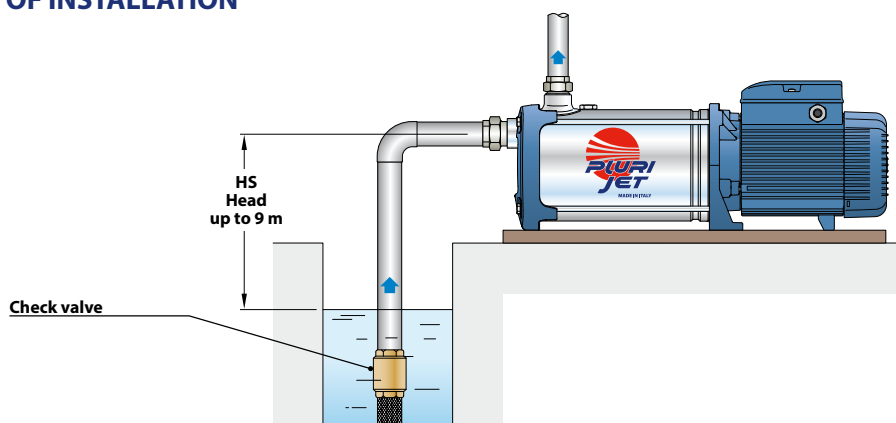

ABSORPTION

TYPE	VOLTAGE
Single-phase	230 V
PLURIJETm 5/90	9.3 A
PLURIJETm 6/90	11.0 A
PLURIJETm 3/130	8.5 A
PLURIJETm 4/130	10.3 A
PLURIJETm 5/130	12.5 A
PLURIJETm 3/200	8.7 A
PLURIJETm 4/200	10.5 A
PLURIJETm 5/200	12.5 A

TYPE	VOLTAGE	
	230 V - Δ	400 V - Y
Three-phase		
PLURIJET 5/90	6.1 A	3.5 A
PLURIJET 6/90	7.3 A	4.2 A
PLURIJET 3/130	5.5 A	3.2 A
PLURIJET 4/130	6.9 A	4.0 A
PLURIJET 5/130	9.0 A	5.2 A
PLURIJET 6/130	9.9 A	5.7 A
PLURIJET 3/200	5.9 A	3.4 A
PLURIJET 4/200	7.3 A	4.2 A
PLURIJET 5/200	9.3 A	5.4 A
PLURIJET 6/200	10.2 A	5.9 A

DIMENSIONS AND WEIGHT

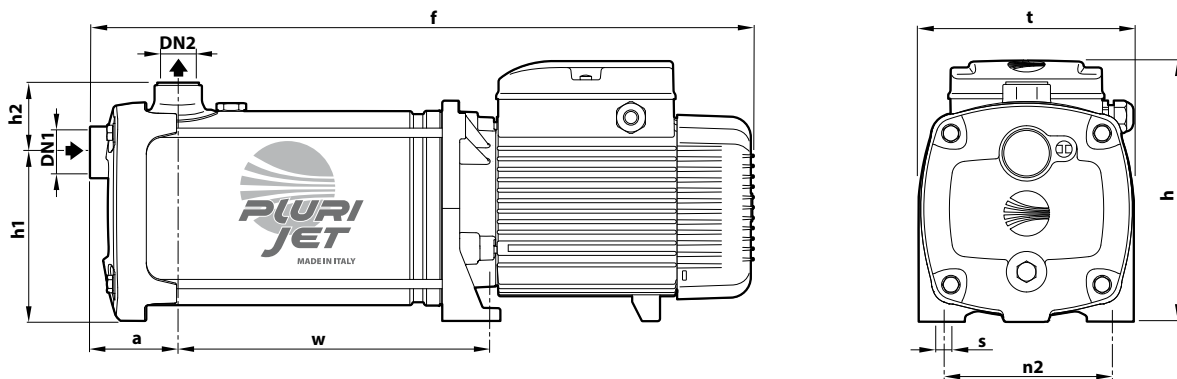

TYPE		PORTS		DIMENSIONS mm									kg	
Single-phase	Three-phase	DN1	DN2	a	f	h	h1	h2	t	n2	w	s	1~	3~
PLURIJETm 5/90	PLURIJET 5/90	1 1/4"	1"	75	549	228	145	59	185	145	243	11	20.8	20.8
PLURIJETm 6/90	PLURIJET 6/90				573						269		22.8	22.8
PLURIJETm 3/130	PLURIJET 3/130				497						191		18.8	18.8
PLURIJETm 4/130	PLURIJET 4/130				523						217		20.8	20.8
PLURIJETm 5/130	PLURIJET 5/130				569						243		24.2	24.2
-	PLURIJET 6/130				595						269		-	25.2
PLURIJETm 3/200	PLURIJET 3/200				497						191		18.8	18.8
PLURIJETm 4/200	PLURIJET 4/200				523						217		20.7	20.7
PLURIJETm 5/200	PLURIJET 5/200				569						243		24.2	24.2
-	PLURIJET 6/200				595						269		-	25.2

MATERIALS AND COMPONENTS

1 Pump body Stainless steel **AISI 304**, provided with ISO 228/1 threaded ports

2 Cover Stainless steel **AISI 304**

3 Impellers Stainless steel **AISI 304**

4 Diffusers Stainless steel **AISI 304**

5 Mechanical seal	Seal	Shaft	Materials
	FN-18	Ø 18 mm	Graphite / Ceramic / NBR

6 Motor shaft Stainless steel **AISI 431**

7 Electric motor **PLURIJETm**: single-phase 230 V - 50Hz with winding integrated thermal motor protection
PLURIJET: three-phase 230/400 V - 50 Hz
 ※ Pumps are equipped with high-efficiency motors (IEC 60034-30-1)
 class **IE2** for single-phase models
 class **IE3** for three-phase models
 Continuous running duty **S1**

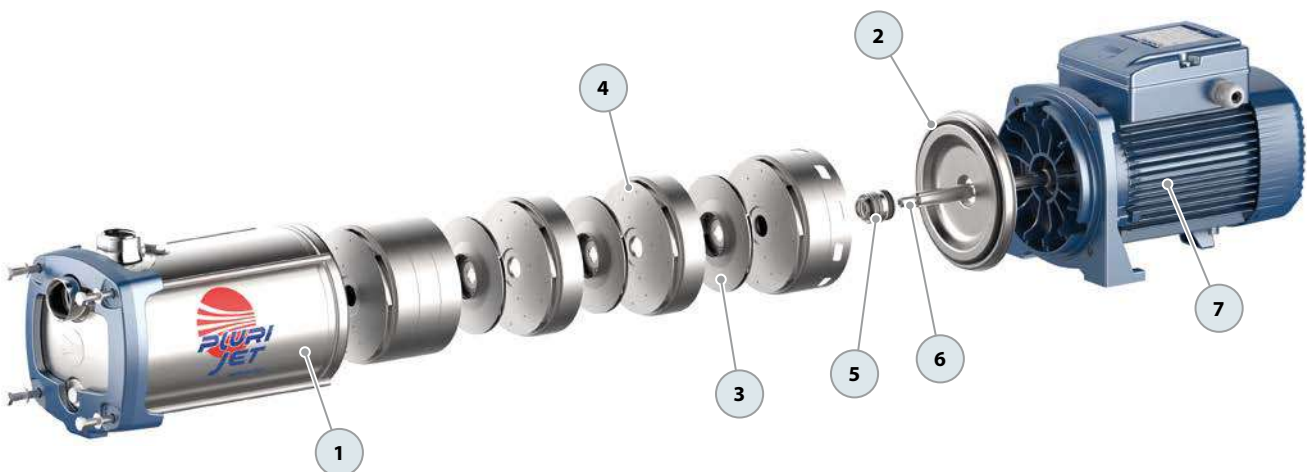

 Domestic use

 Agricultural use

 Industrial use



PERFORMANCE RANGE

- Flow rate up to **900 l/min** (54 m³/h)
- Head up to **20.5 m**

INSTALLATION AND USE

Designed to transfer liquids that will not damage the pump's components, NGAS pumps feature an open impeller design.

This allows them to efficiently handle impurity-laden fluids without clogging, making them ideal for various applications including transfers from channels, rivers, tanks, basins, and more.

NGAs pumps are particularly suitable for pumping non-entirely clean liquids, facilitating the movement of solid particles up to **20 mm** in size.

ELECTRIC MOTOR

The three-phase pumps are equipped with newly developed electric motors designed to work with inverters, which guarantee stable and quiet operation.

Efficiency class **IE3** for three-phase motors and **IE2** for single-phase motors, with class F insulation and IPX4 protection.

APPLICATION LIMITS

- Manometric suction head up to **7 m**
- Liquid temperature between **-10 °C** up and **+90 °C**
- Ambient temperature between **-10 °C** and **+40 °C**
- Maximum working pressure:
 - **6 bar** for NGA1 and NGA2
 - **10 bar** for NGA3
- Passing solid in suspension up to:
 - **Ø 12 mm** for NGA1 and NGA2
 - **Ø 20 mm** for NGA3

AVAILABLE UPON REQUEST

- ✘ Mechanical seal options available
- ✘ Pump body with NPT threaded ports ANSI B 1.20.1
- ✘ On request up to **110 °C**
- ✘ **IP X5** protection for **NGA 3**
- ✘ Different voltage requirements 60 Hz frequency

- ✘ Supply of ISO 228/1 flanges for suction and delivery ports in AISI 304 stainless steel



CURVES AND PERFORMANCE DATA – HS=0 m

50 Hz

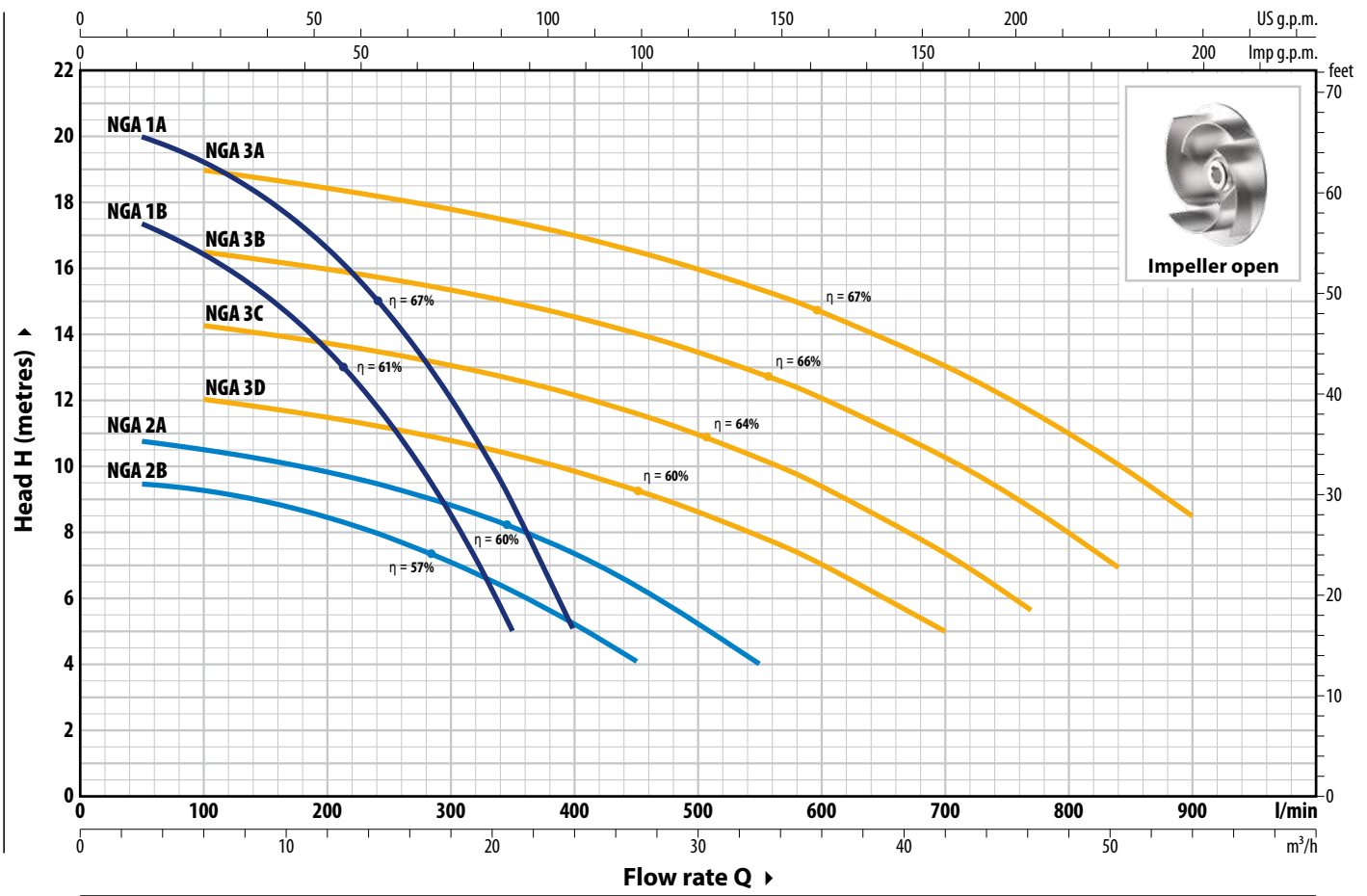

TYPE		POWER (P ₂)		1~3~	Q	Flow rate											
Single-phase	Three-phase	kW	HP			m ³ /h	0	3	6	9	12	15	18	21	24		
NGAm 1B	NGA 1B	0.55	0.75	IE2 IE3	H metres	0	50	100	150	200	250	300	350	400			
NGAm 1A	NGA 1A	0.75	1			18	17.4	16.4	15.2	13.5	11.3	8.7	5				
						20.5	20	19.3	18	16.6	14.7	12	9	5			

TYPE		POWER (P ₂)		1~3~	Q	Flow rate														
Single-phase	Three-phase	kW	HP			m ³ /h	0	3	6	12	18	24	27	33	42	46	51	54		
NGAm 2B	NGA 2B	0.55	0.75	IE2 IE3	H metres	0	50	100	200	300	400	450	550	700	770	840	900			
NGAm 2A	NGA 2A	0.75	1			9.5	9.4	9.3	8.4	7	5.2	4								
NGAm 3D	NGA 3D	1.1	1.5			11	10.8	10.5	9.8	8.8	7.4	6.4	4							
NGAm 3C	NGA 3C	1.5	2			12.5	–	12	11.5	10.8	9.8	9.3	7.8	5						
NGAm 3B	NGA 3B	1.8	2.5			14.8	–	14.4	13.8	13.1	12.2	11.7	10.3	7.4	5.7					
NGAm 3A	NGA 3A	2.2	3			17	–	16.5	16	15.3	14.5	14	12.8	10.3	8.8	7				
						19.5	–	19	18.4	17.8	17	16.5	15.4	13	11.5	10	8.5			

Q = Flow rate H = Total manometric head HS = Suction height

Performance curves comply with EN ISO 9906 Grade 3B tolerance limits.

ABSORPTION

TYPE	VOLTAGE
Single-phase	230 V
NGAm 1B	5.5 A
NGAm 1A	6.0 A
NGAm 2B	5.0 A
NGAm 2A	5.7 A
NGAm 3D	7.5 A
NGAm 3C	9.5 A
NGAm 3B	10.5 A
NGAm 3A	12.5 A

TYPE	VOLTAGE	
Three-phase	230 V - Δ	400 V - Ǝ
NGA 1B	3.8 A	2.2 A
NGA 1A	4.2 A	2.4 A
NGA 2B	3.5 A	2.0 A
NGA 2A	4.0 A	2.3 A
NGA 3D	5.0 A	2.9 A
NGA 3C	6.1 A	3.5 A
NGA 3B	7.8 A	4.5 A
NGA 3A	8.3 A	4.8 A

DIMENSIONS AND WEIGHT

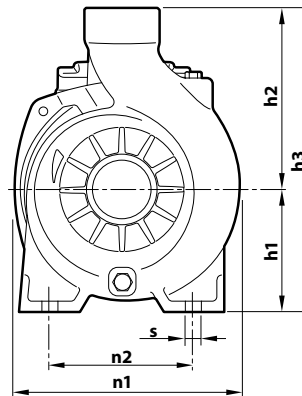
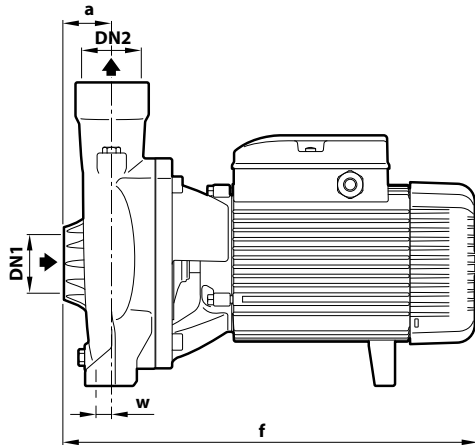

WITH THREADED PORTS

TYPE		PORTS		DIMENSIONS mm									kg	
Single-phase	Three-phase	DN1	DN2	a	f	h1	h2	h3	n1	n2	w	s	1~	3~
NGAm 1B	NGA 1B	1½"	1½"	40	299	92	135	227	190	160	6	11	12.6	12.6
NGAm 1A	NGA 1A			32									12.7	12.6
NGAm 2B	NGA 2B			32									12.7	12.6
NGAm 2A	NGA 2A			32									12.7	12.6
NGAm 3D	NGA 3D	2"	2"	48	387	120	178	298	217	140	18	11.5	22.0	21.2
NGAm 3C	NGA 3C			407									22.9	22.9
NGAm 3B	NGA 3B			407									25.4	25.5
NGAm 3A	NGA 3A			407									25.5	25.5

WITH FLANGED PORTS

TYPE		PORTS		DIMENSIONS mm						
Single-phase	Three-phase	DN1	DN2	a	f	h1	h2	h3		
NGAm 1B	NGA 1B	40	40	60	334	92	156	248		
NGAm 1A	NGA 1A			52	342					
NGAm 2B	NGA 2B			50	50	70	408	120	200	320
NGAm 2A	NGA 2A					428				
NGAm 3D	NGA 3D	428								
NGAm 3C	NGA 3C	428								

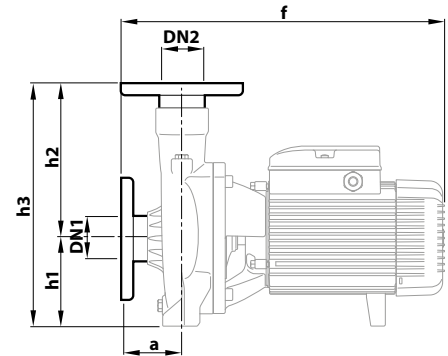

FLANGE	D	K	F	HOLES	
DN	mm	mm	mm	N°	Ø (mm)
40	150	110	78	4	18
50	165	125	99	4	18

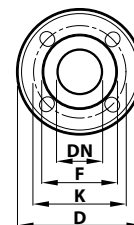

MATERIALS AND COMPONENTS

1 Pump body Cast iron JL 250 with cataphoresis treatment with ISO 228/1 threaded ports

2 Cover Cast iron JL 200 for NGA3
AISI 304 stainless steel for NGA1 and NGA2

3 Impeller Open impeller in **AISI 316** stainless steel (from January 2024)

4 Mechanical seal	Water pump	Seal	Shaft	Materials
	NGA1	AR-14	Ø 14 mm	Ceramic / Graphite / NBR
NGA2	FN-18	Ø 18 mm	Graphite / Ceramic / NBR	
NGA3	FN-18	Ø 18 mm	Graphite / Ceramic / NBR	

5 Motor shaft Stainless steel **AISI 431**

6 Electric motor **NGAm:** single-phase 230 V - 50Hz with winding integrated thermal motor protection
NGA: three-phase 230/400 V - 50 Hz
※ Pumps are equipped with high-efficiency motors (IEC 60034-30-1)
class **IE2** for single-phase models
class **IE3** for three-phase models
Continuous running duty **S1**

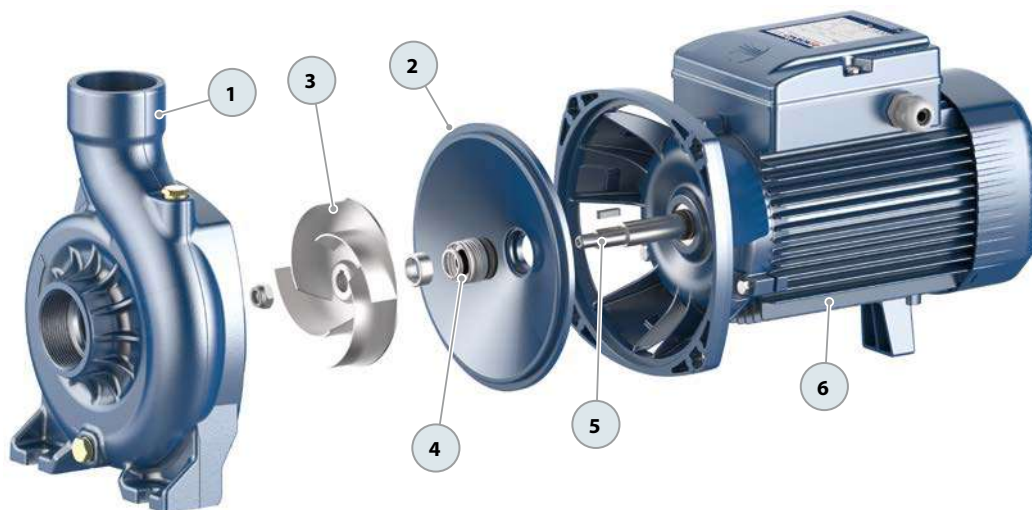



Civil use



Agricultural use



Industrial use

※ Pump entirely made of
AISI316 stainless steel



PERFORMANCE RANGE

- Flow rate up to **900 l/min** (54 m³/h)
- Head up to **20.5 m**

INSTALLATION AND USE

Designed to transfer liquids that will not damage the pump's components, NGA-PRO pumps feature an open impeller design. This allows them to efficiently handle impurity-laden fluids without clogging, making them ideal for various applications including transfers from channels, rivers, tanks, basins, and more.

All components in contact with pumped liquids are constructed from **AISI 316** stainless steel.

NGA-PRO pumps are particularly suitable for pumping non-entirely clean liquids, facilitating the movement of solid particles up to **20 mm** in size.

ELECTRIC MOTOR

The three-phase pumps are equipped with newly developed electric motors designed to work with inverters, which guarantee stable and quiet operation.

Efficiency class **IE3** for three-phase motors and **IE2** for single-phase motors, with class F insulation and IPX4 protection.

APPLICATION LIMITS

- Manometric suction head up to **7 m**
- Liquid temperature between **-10 °C** and **+90 °C**
- Ambient temperature between **-10 °C** and **+40 °C**
- Maximum working pressure:
 - **6 bar** for NGA1-PRO and NGA2-PRO
 - **10 bar** for NGA3-PRO
- Passing solid in suspension up to:
 - **Ø 12 mm** for NGA1-PRO and NGA2-PRO
 - **Ø 20 mm** for NGA3-PRO

AVAILABLE UPON REQUEST

- ※ Mechanical seal options available
- ※ Standardised mechanical seal with anti-rotation (NGA3-PRO)
- ※ Pump body with NPT threaded ports ANSI B 1.20.1
- ※ On request up to **110 °C**
- ※ **IP X5** protection for **NGA 3-PRO**
- ※ Different voltage requirements 60 Hz frequency
- ※ ISO 228/1 standard flanges for suction and discharge openings, made of AISI 304 stainless steel



CURVES AND PERFORMANCE DATA – HS=0 m

50 Hz

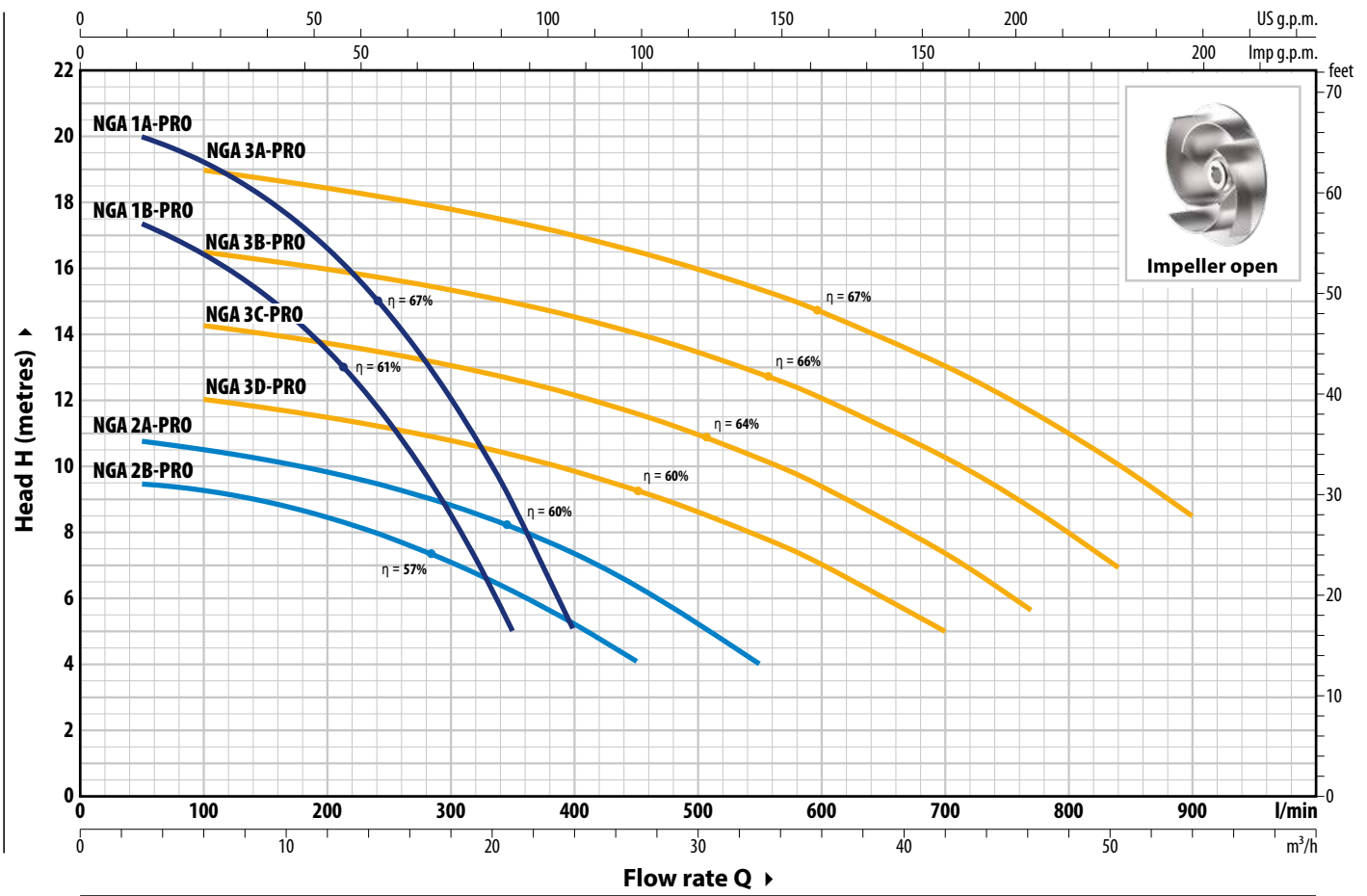

TYPE		POWER (P ₂)		1~3~	Q	m ³ /h											
Single-phase	Three-phase	kW	HP			0	3	6	9	12	15	18	21	24			
NGAm 1B - PRO	NGA 1B - PRO	0.55	0.75	IE2 IE3	H metres	0	50	100	150	200	250	300	350	400			
NGAm 1A - PRO	NGA 1A - PRO	0.75	1			18	17.4	16.4	15.2	13.5	11.3	8.7	5				
						20.5	20	19.3	18.1	16.6	14.7	12.1	9	5			

TYPE		POWER (P ₂)		1~3~	Q	m ³ /h															
Single-phase	Three-phase	kW	HP			0	3	6	12	18	24	27	33	42	46	51	54				
NGAm 2B - PRO	NGA 2B - PRO	0.55	0.75	IE2 IE3	H metres	0	50	100	200	300	400	450	550	700	770	840	900				
NGAm 2A - PRO	NGA 2A - PRO	0.75	1			9.5	9.4	9.3	8.4	7	5.2	4									
NGAm 3D - PRO	NGA 3D - PRO	1.1	1.5			11	10.8	10.5	9.8	8.8	7.4	6.4	4								
NGAm 3C - PRO	NGA 3C - PRO	1.5	2			12.5	-	12	11.5	10.8	9.8	9.3	7.8	5							
NGAm 3B - PRO	NGA 3B - PRO	1.8	2.5			14.8	-	14.4	13.8	13.1	12.2	11.7	10.3	7.4	5.7						
NGAm 3A - PRO	NGA 3A - PRO	2.2	3			17	-	16.5	16	15.3	14.5	14	12.8	10.3	8.8	7					
						19.5	-	19	18.4	17.8	17	16.5	15.4	13	11.5	10	8.5				

Q = Flow rate H = Total manometric head HS = Suction height

Performance curves comply with EN ISO 9906 Grade 3B tolerance limits.

ABSORPTION

TYPE	VOLTAGE
Single-phase	230 V
NGAm 1B - PRO	5.5 A
NGAm 1A - PRO	6.0 A
NGAm 2B - PRO	5.0 A
NGAm 2A - PRO	5.7 A
NGAm 3D - PRO	7.5 A
NGAm 3C - PRO	9.5 A
NGAm 3B - PRO	10.5 A
NGAm 3A - PRO	12.5 A

TYPE	VOLTAGE	
	230 V - Δ	400 V - Δ
Three-phase		
NGA 1B - PRO	3.8 A	2.2 A
NGA 1A - PRO	4.2 A	2.4 A
NGA 2B - PRO	3.5 A	2.0 A
NGA 2A - PRO	4.0 A	2.3 A
NGA 3D - PRO	5.0 A	2.9 A
NGA 3C - PRO	6.1 A	3.5 A
NGA 3B - PRO	7.8 A	4.5 A
NGA 3A - PRO	8.3 A	4.8 A

DIMENSIONS AND WEIGHT

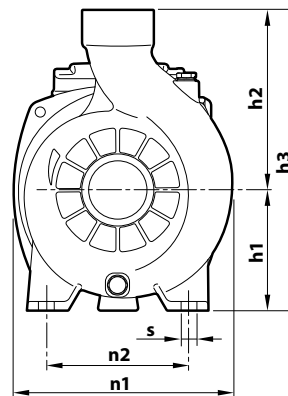
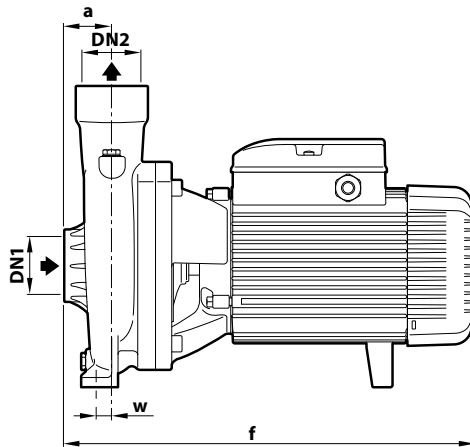

※ WITH THREADED PORTS

TYPE		PORTS		DIMENSIONS mm										kg	
Single-phase	Three-phase	DN1	DN2	a	f	h1	h2	h3	n1	n2	w	s	1~	3~	
NGAm 1B - PRO	NGA 1B - PRO	1½"	1½"	40	299	92	135	227	190	160	6	11	12.7	12.7	
NGAm 1A - PRO	NGA 1A - PRO												12.7	12.7	
NGAm 2B - PRO	NGA 2B - PRO			12.7									12.7		
NGAm 2A - PRO	NGA 2A - PRO			12.7									12.7		
NGAm 3D - PRO	NGA 3D - PRO	2"	2"	48	387	120	178	298	217	140	18	11.5	22.0	21.2	
NGAm 3C - PRO	NGA 3C - PRO												22.9	22.9	
NGAm 3B - PRO	NGA 3B - PRO			25.4									25.5		
NGAm 3A - PRO	NGA 3A - PRO			25.5									25.5		

※ WITH FLANGED PORTS

TYPE		PORTS		DIMENSIONS mm					
Single-phase	Three-phase	DN1	DN2	a	f	h1	h2	h3	
NGAm 1B - PRO	NGA 1B - PRO	40	40	60	334	92	156	248	
NGAm 1A - PRO	NGA 1A - PRO								
NGAm 2B - PRO	NGA 2B - PRO			52					342
NGAm 2A - PRO	NGA 2A - PRO								
NGAm 3D - PRO	NGA 3D - PRO	50	50	70	408	120	200	320	
NGAm 3C - PRO	NGA 3C - PRO								
NGAm 3B - PRO	NGA 3B - PRO			428					
NGAm 3A - PRO	NGA 3A - PRO								

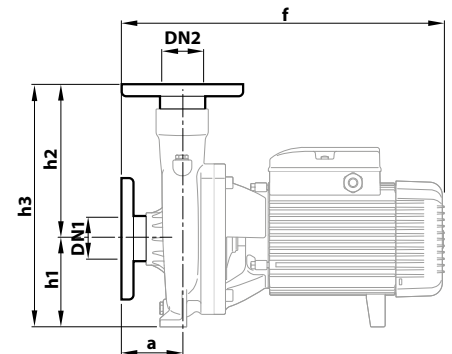

FLANGE	D	K	F	HOLES	
				N°	Ø (mm)
DN	mm	mm	mm		
40	150	110	78	4	18
50	165	125	99	4	18

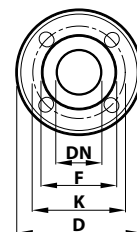

MATERIALS AND COMPONENTS

1 Pump body Stainless steel **AISI 316** with ISO 228/1 threaded ports

2 Cover Stainless steel **AISI 316**

3 Impeller Open impeller in **AISI 316** stainless steel (from January 2024)

4 Mechanical seal	Water pump	Seal	Shaft	Materials
	NGA1-PRO	AR-14S	Ø 14 mm	Ceramic / Graphite / Viton
	NGA2-PRO			
	NGA3-PRO	FN-18 V6	Ø 18 mm	Graphite / Ceramic / Viton

5 Motor shaft Stainless steel **AISI 316L**

6 Electric motor **NGAm-PRO**: single-phase 230 V - 50Hz with winding integrated thermal motor protection
NGA-PRO: three-phase 230/400 V - 50 Hz
 ※ Pumps are equipped with high-efficiency motors (IEC 60034-30-1)
 class **IE2** for single-phase models
 class **IE3** for three-phase models
 Continuous running duty **S1**

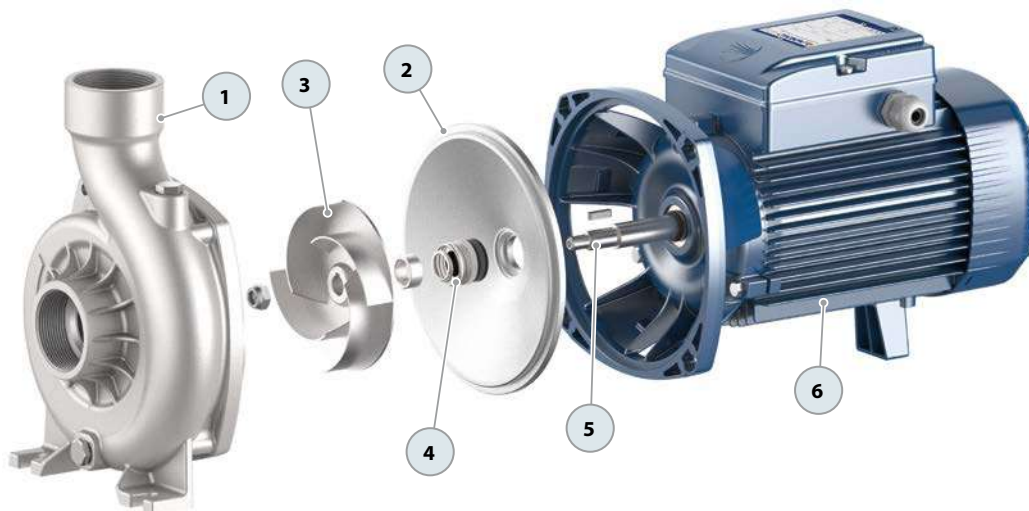

HF Centrifugal pumps

Medium range

-  Clean water
-  Agricultural use
-  Industrial use



PERFORMANCE RANGE

- Flow rate up to **700 l/min** (42 m³/h)
- Head up to **39 m**

INSTALLATION AND USE

Designed for civil and agricultural use.

Their high-efficiency levels and capability for continuous operation make them an ideal choice for furrow and sprinkler irrigation, in addition to drawing water from lakes, rivers, and wells. They are also suitable for a wide range of industrial applications that require substantial flow rates at medium-low head pressures.

ELECTRIC MOTOR

The three-phase pumps are equipped with newly developed electric motors designed to work with inverters, which guarantee stable and quiet operation.

Efficiency class **IE3** for three-phase motors and **IE2** for single-phase motors, with class F insulation and IPX4 protection.

APPLICATION LIMITS

- Manometric suction head up to **7 m**
- Liquid temperature between **-10 °C** and **+90 °C**
- Ambient temperature up to **+40 °C**
- Maximum working pressure:
 - **6 bar** for HF 5-50-51
 - **10 bar** for HF 5M-70

AVAILABLE UPON REQUEST

- ✘ Mechanical seal options available
- ✘ Different voltage requirements 60 Hz frequency
- ✘ IP X5 protection for HF 5M-70

CURVES AND PERFORMANCE DATA – HS=0 m

50 Hz

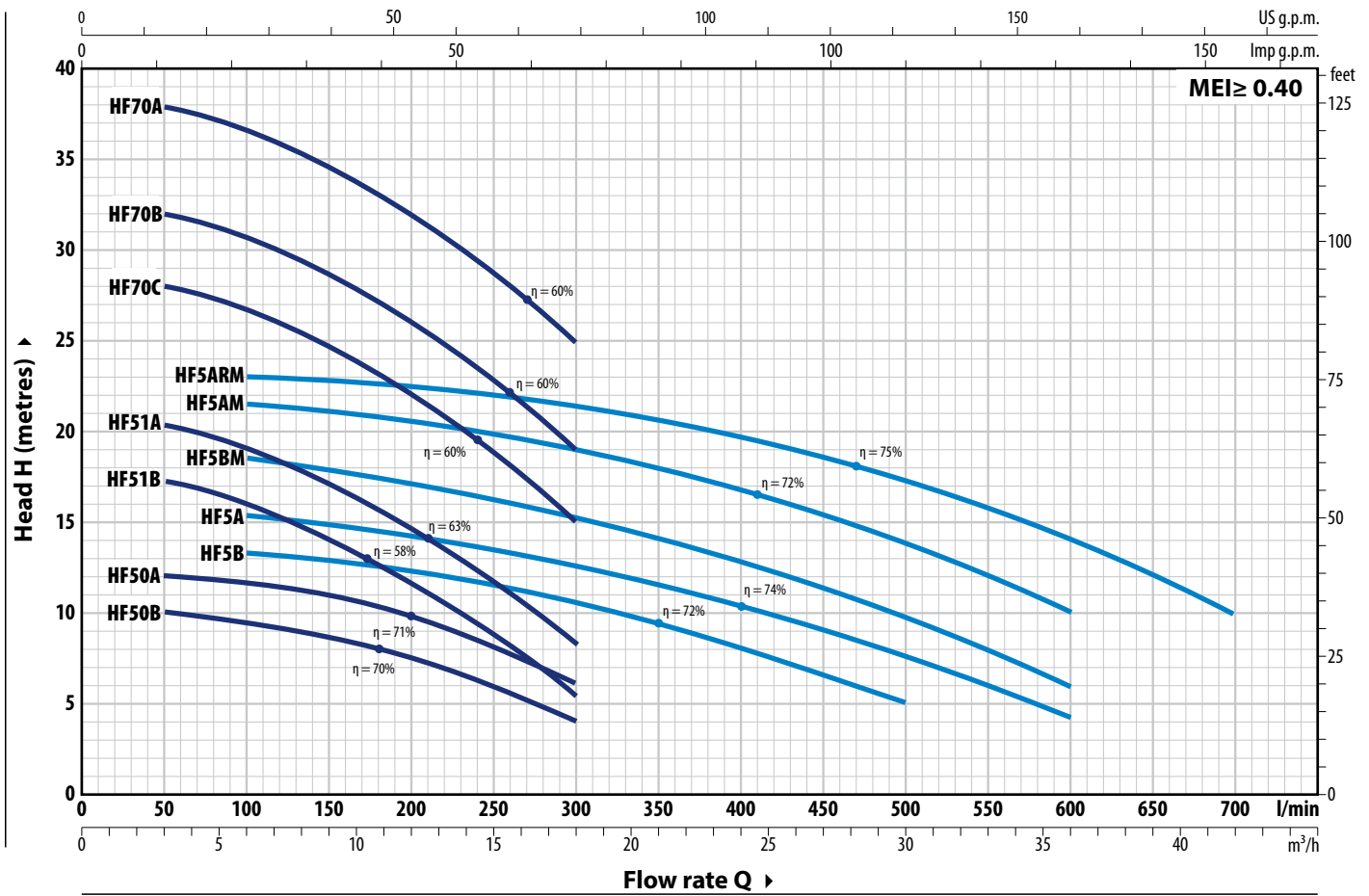

TYPE		POWER (P ₂)		1~3~	Q	m ³ /h															
Single-ph.	Three-ph.	kW	HP			0	3	6	9	12	15	18	21	24	30	36	42				
						0	50	100	150	200	250	300	350	400	500	600	700				
HFm 50B	HF 50B	0.37	0.50	IE2 IE3	H metres	10	10	9.5	8.5	7.5	6	4									
HFm 50A	HF 50A	0.55	0.75			12	12	11.5	11	9.6	8	6									
HFm 51B	HF 51B	0.55	0.75			18.2	17.2	16	14	11.5	9	5.4									
HFm 51A	HF 51A	0.75	1			21.2	20.2	19	17	14.5	11.6	8.4									
HFm 70C	HF 70C	1.1	1.5			29	28	26.5	24.5	22	18.5	15									
HFm 70B	HF 70B	1.5	2			33	32	30.5	28.5	26	22.5	19									
-	HF 70A	2.2	3			39	38	36.5	34.5	32	28.5	25									
HFm 5B	HF 5B	0.75	1			13.7	-	13.2	13	12.5	11.6	10.5	9.2	8	5						
HFm 5A	HF 5A	0.90	1.25			16	-	15.4	15	14.2	13.5	12.6	11.5	10.4	7.6	4.3					
HFm 5BM	HF 5BM	1.1	1.5			19	-	18.5	18	17	16	15.2	14	12.8	9.7	6					
HFm 5AM	HF 5AM	1.5	2	22	-	21.5	21	20.5	19.8	19	18	16.8	13.8	10							
HFm 5ARM	HF 5ARM	2.2	3	23.5	-	23	22.6	22.2	21.7	21	20.2	19.3	17	13.9	10						

Q = Flow rate H = Total manometric head HS = Suction height

Performance curves comply with EN ISO 9906 Grade 3B tolerance limits.

ABSORPTION

TYPE	VOLTAGE
Single-ph.	230 V
HFm 50B	2.8 A
HFm 50A	3.8 A
HFm 51B	4.7 A
HFm 51A	5.6 A
HFm 70C	8.0 A
HFm 70B	10.0 A
HFm 5B	5.0 A
HFm 5A	6.0 A
HFm 5BM	7.7 A
HFm 5AM	10.1 A
HFm 5ARM	11.5 A

TYPE	VOLTAGE	
	230 V - Δ	400 V - Y
HF 50B	2.1 A	1.2 A
HF 50A	2.9 A	1.7 A
HF 51B	3.6 A	2.1 A
HF 51A	4.3 A	2.5 A
HF 70C	6.1 A	3.5 A
HF 70B	7.4 A	4.3 A
HF 70A	9.5 A	5.5 A
HF 5B	3.6 A	2.1 A
HF 5A	4.0 A	2.3 A
HF 5BM	5.7 A	3.3 A
HF 5AM	7.1 A	4.1 A
HF 5ARM	8.0 A	4.6 A

DIMENSIONS AND WEIGHT

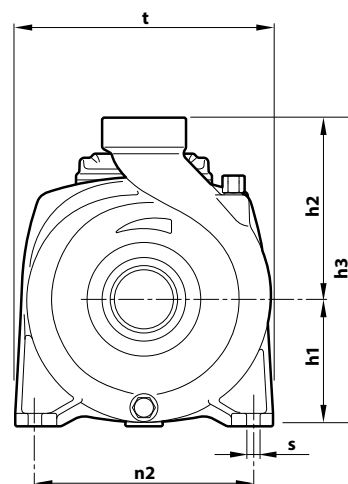
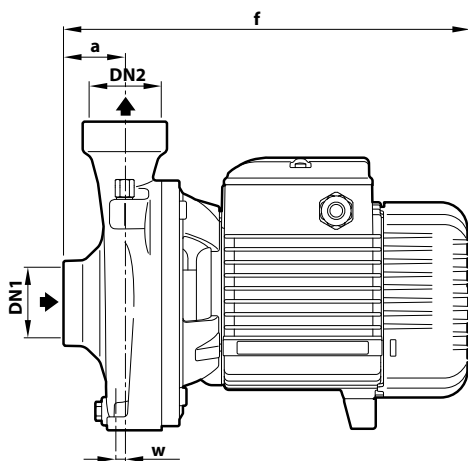

TYPE		PORTS		DIMENSIONS mm									kg		
Single-ph.	Three-ph.	DN1	DN2	a	f	h1	h2	h3	t	n2	w	s	1~	3~	
HFm 50B	HF 50B	1½"	1½"	42	270	82	118	200	166	135	-8	10	8.1	8.1	
HFm 50A	HF 50A												8.9	8.2	
HFm 51B	HF 51B			45	303	92	133	225	190	160	2		12.9	12.7	
HFm 51A	HF 51A												13.2	13.2	
HFm 70C	HF 70C			48.5	373	114	155	269	216	171	12		12	20.0	20.0
HFm 70B	HF 70B													21.5	21.5
-	HF 70A	393	-									24.3			
HFm 5B	HF 5B	2"	2"	43	316	97	141	238	192	160	-68	10	14.1	14.1	
HFm 5A	HF 5A												15.1	14.1	
HFm 5BM	HF 5BM			59	386	110	150	260	208	12.5	11		20.3	20.3	
HFm 5AM	HF 5AM												21.8	21.8	
HFm 5ARM	HF 5ARM			406	-	24.6									

MATERIALS AND COMPONENTS

1 Pump body	Cast iron with ISO 228/1 threaded ports			
2 Cover	Stainless steel AISI 304 (cast iron for HF 5M-70)			
3 Impeller	Stainless steel AISI 304 (HF50 Start of production 06.2024) (HF51 Start of production 06.2024) (HF70 Start of production 04.2024) (HF5ARM Start of production 06.2024)			
4 Mechanical seal	Water pump	Seal	Shaft	Materials
	HF 50	AR-12	Ø 12 mm	Ceramic / Graphite / NBR
	HF 5-51	AR-14	Ø 14 mm	Ceramic / Graphite / NBR
	HF 5M-70	FN-18	Ø 18 mm	Graphite / Ceramic / NBR
5 Motor shaft	Stainless steel AISI 431			
6 Electric motor	<p>HFm: single-phase 230 V - 50 Hz with winding integrated thermal motor protection</p> <p>HF: three-phase 230/400 V - 50 Hz</p> <p>※ Pumps are equipped with high-efficiency motors (IEC 60034-30-1)</p> <p>class IE2 for single-phase models</p> <p>class IE3 for three-phase models</p> <p>Continuous running duty S1</p>			

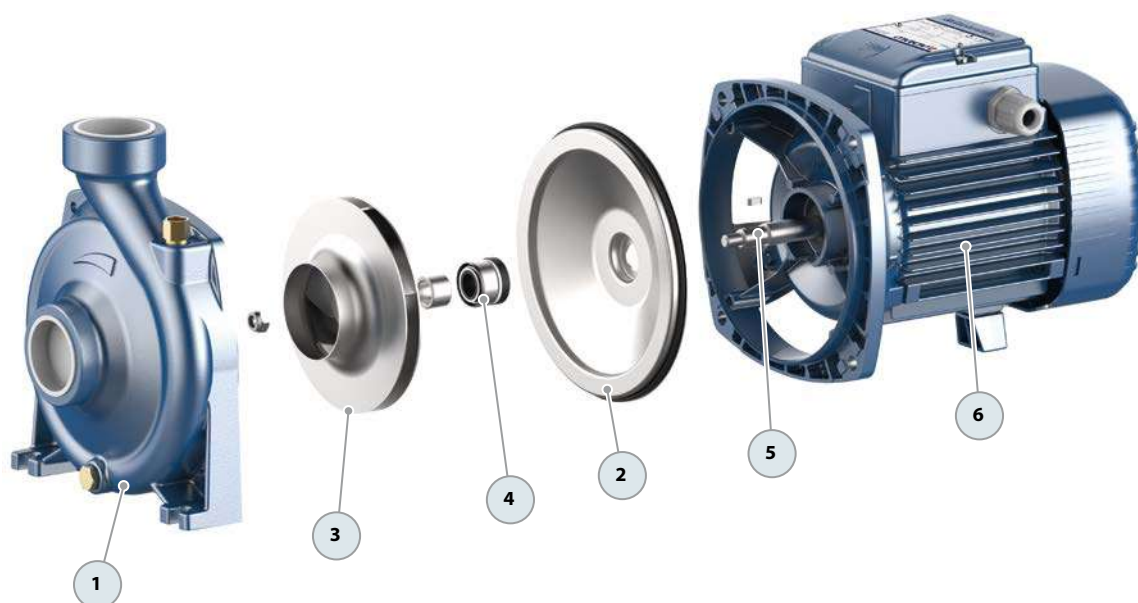

HF Centrifugal pumps

High flow rates

-  Clean water
-  Agricultural use
-  Industrial use



PERFORMANCE RANGE

- Flow rate up to **2400 l/min** (144 m³/h)
- Head up to **24.5 m**

INSTALLATION AND USE

Designed for civil and agricultural use.

Their high-efficiency levels and capability for continuous operation make them an ideal choice for furrow and sprinkler irrigation, in addition to drawing water from lakes, rivers, and wells. They are also suitable for a wide range of industrial applications that require substantial flow rates at medium-low head pressures.

ELECTRIC MOTOR

The three-phase pumps are equipped with newly developed electric motors designed to work with inverters, which guarantee stable and quiet operation.

Efficiency class **IE3** for three-phase motors and **IE2** for single-phase motors, with class F insulation and IPX4 protection.

APPLICATION LIMITS

- Manometric suction head up to **7 m**
- Liquid temperature between **-10 °C** and **+90 °C**
- Ambient temperature up to **+40 °C**
- Maximum working pressure:
 - **6 bar** for HF 4
 - **10 bar** for HF 6-8-20-30

AVAILABLE UPON REQUEST

- ✘ Mechanical seal options available
- ✘ Different voltage requirements 60 Hz frequency

CURVES AND PERFORMANCE DATA – HS=0 m

50 Hz

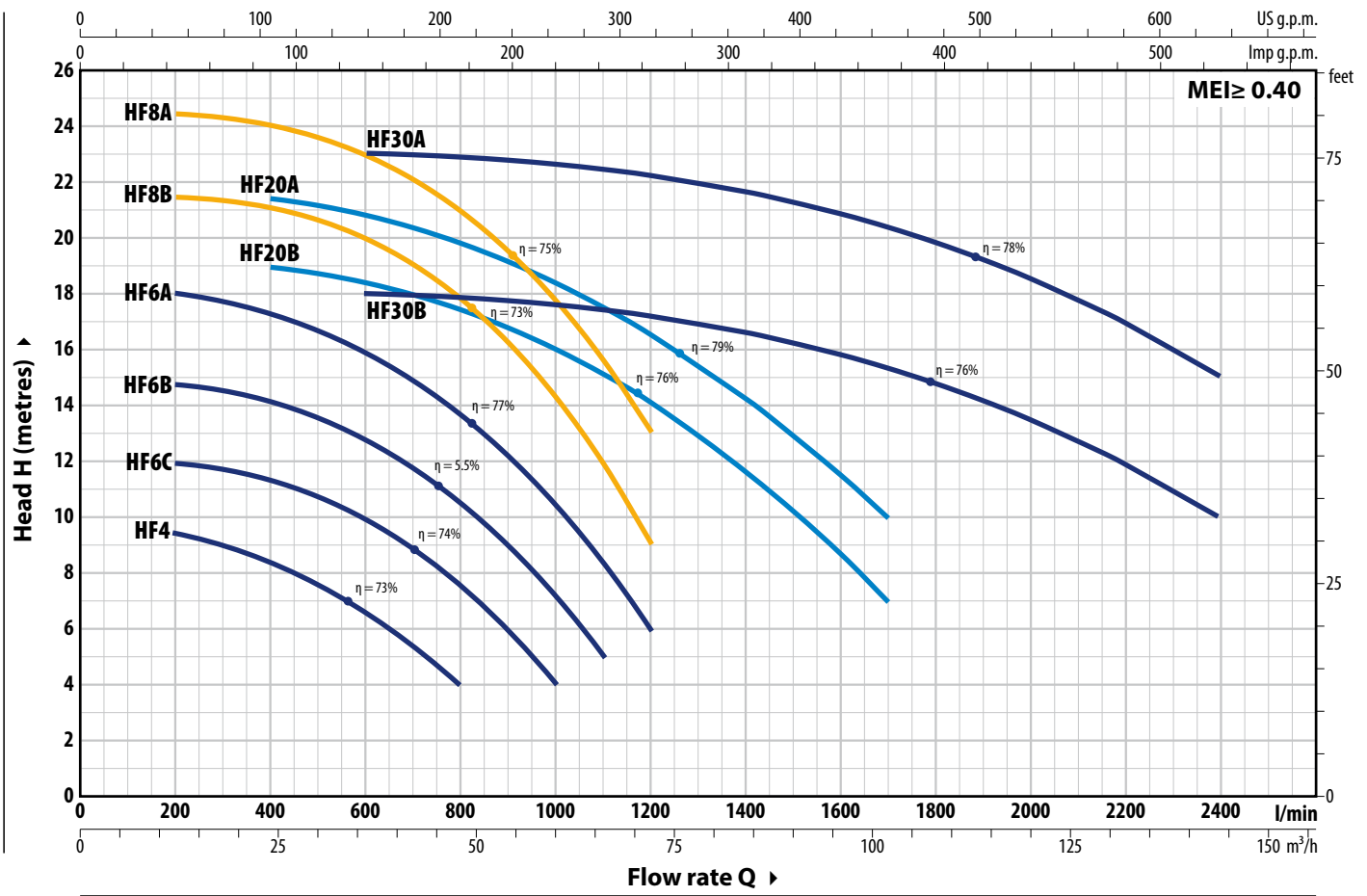

TYPE		POWER (P ₂)		1~3~	Q	H metres																
Single-ph.	Three-ph.	kW	HP			0	12	18	24	30	36	42	48	60	66	72	102	114	144			
					l/min	0	200	300	400	500	600	700	800	1000	1100	1200	1700	1900	2400			
HFm 4	HF 4	0.75	1	IE2 IE3		9.8	9.5	9	8.5	7.6	6.6	5.4	4									
HFm 6C	HF 6C	1.1	1.5			12	12	11.8	11.4	10.8	10	9	7.6	4								
HFm 6B	HF 6B	1.5	2			14.8	14.8	14.6	14.2	13.6	12.8	11.8	10.5	7.2	5							
HFm 6A	HF 6A	2.2	3			18.5	18	17.8	17.4	16.8	16	15	13.7	10.4	8.4	6						
-	HF 8B	3	4			21.5	21.5	21.4	21	20.7	20	19	17.8	14.3	12	9						
-	HF 8A	4	5.5			24.5	24.5	24.4	24	23.6	23	22	21	17.7	15.6	13						
-	HF 20B	3	4			19	-	-	19	18.8	18.4	18	17.5	16	15.2	14.2	7					
-	HF 20A	4	5.5			21.5	-	-	21.5	21.3	21	20.5	20	18.5	17.6	16.6	10					
-	HF 30B	5.5	7.5			18	-	-	-	-	18	17.9	18	17.6	17.4	17.2	15.3	14.2	10			
-	HF 30A	7.5	10			23	-	-	-	-	23	23	22.8	22.6	22.4	22.2	20.4	19.2	15			

Q = Flow rate H = Total manometric head HS = Suction height

Performance curves comply with EN ISO 9906 Grade 3B tolerance limits.

ABSORPTION

TYPE	VOLTAGE
Single-ph.	230 V
HFm 4	5.9 A
HFm 6C	8.8 A
HFm 6B	10.4 A
HFm 6A	13.5 A

TYPE	VOLTAGE			
	230 V - Δ	400 V - 人	400 V - Δ	690 V - 人
HF 4	4.3 A	2.5 A	-	-
HF 6C	6.2 A	3.6 A	-	-
HF 6B	7.8 A	4.5 A	-	-
HF 6A	9.0 A	5.2 A	-	-
HF 8B	13.0 A	7.5 A	-	-
HF 8A	15.7 A	9.1 A	-	-
HF 20B	14.7 A	8.5 A	-	-
HF 20A	15.2 A	8.8 A	-	-
HF 30B	-	-	12.3 A	7.1 A
HF 30A	-	-	16.5 A	9.5 A

DIMENSIONS AND WEIGHT

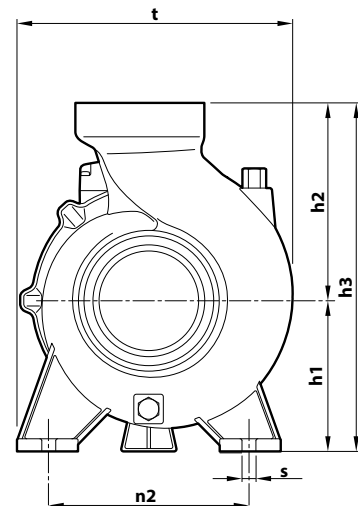
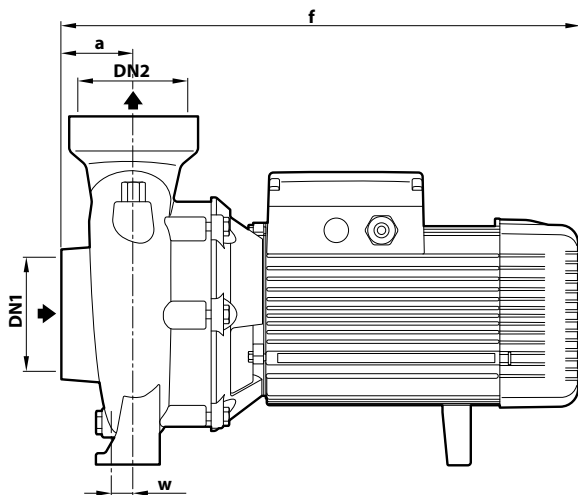

TYPE		PORTS		DIMENSIONS mm									kg		
Single-ph.	Three-ph.	DN1	DN2	a	f	h1	h2	h3	t	n2	w	s	1~	3~	
HFm 4	HF 4	2½"	2½"	47	317	97	143	240	198	155	-63	10	14.5	14.5	
HFm 6C	HF 6C	3"	3"	68	408	120	190	310	240	178	5	12	25.7	25.7	
HFm 6B	HF 6B				428								26.8	26.8	
HFm 6A	HF 6A				428								29.6	29.6	
-	HF 8B	4"	4"	71	474	132	180	312	245	190	27	14	-	37.6	
-	HF 8A				479				41.0						
-	HF 20B				255				37.6						
-	HF 20A				255	41.0									
-	HF 30B				76.5	497	160	210	370	292	212	27	14	-	52.0
-	HF 30A					547								-	58.0

MATERIALS AND COMPONENTS

1 Pump body Cast iron with ISO 228/1 threaded ports

2 Cover Cast iron (**AISI 304** stainless steel for HF 4)

3 Impeller Stainless Steel **AISI 304** for HF 4-6
Brass for HF 8
Cast iron for HF 20, HF 30

4 Mechanical seal	Water pump	Seal	Shaft	Materials
	HF 4	AR-14	Ø 14 mm	Ceramic / Graphite / NBR
HF 6	FN-18	Ø 18 mm	Graphite / Ceramic / NBR	
HF 8, HF 20	FN-20	Ø 20 mm	Graphite / Ceramic / NBR	
HF 30	FN-24	Ø 24 mm	Graphite / Ceramic / NBR	

5 Motor shaft Stainless steel **AISI 431**

6 Electric motor **HFm**: single-phase 230 V - 50 Hz with winding integrated thermal motor protection
HF: three-phase 230/400 V - 50 Hz up to 4 kW
400/690 V - 50 Hz from 5.5 to 7.5 kW.
✳ Pumps are equipped with high-efficiency motors (IEC 60034-30-1)
class **IE2** for single-phase models
class **IE3** for three-phase models
Continuous running duty **S1**



-  Clean water
-  Agricultural use
-  Civil use
-  Industrial use



FIELD PERFORMANCE

- Flow rate up to **700 l/min** (42 m³/h)
- Head up to **26 m**

INSTALLATION AND USE

WR centrifugal pumps are designed to transfer clean water free from abrasive particles and liquids that will not damage the pump's components.

Suitable for civil and industrial applications such as **heating, air conditioning, cooling, and circulation** systems.

ELECTRIC MOTOR

The three-phase pumps are equipped with newly developed electric motors designed to work with inverters, which guarantee stable and quiet operation.

Efficiency class **IE3** for three-phase motors and **IE2** for single-phase motors, with class F insulation and IPX4 protection.

INCLUDES

- ✘ Pump's impeller directly mounted on the motor shaft.
- ✘ Pump body with suction and discharge ports of identical diameter.

APPLICATION LIMITS

- Manometric suction head up to **7 m**
- Liquid temperature between **-10 °C** and **+110 °C**
- Ambient temperature between **-10 °C** and **+40 °C**
- Maximum pressure in the pump body **10 bar** (PN10)

AVAILABLE UPON REQUEST

- ✘ Counterflange KIT including screws, nuts and gaskets
- ✘ Mechanical seal options available
- ✘ Different voltage requirements 60 Hz frequency

WR 40/125

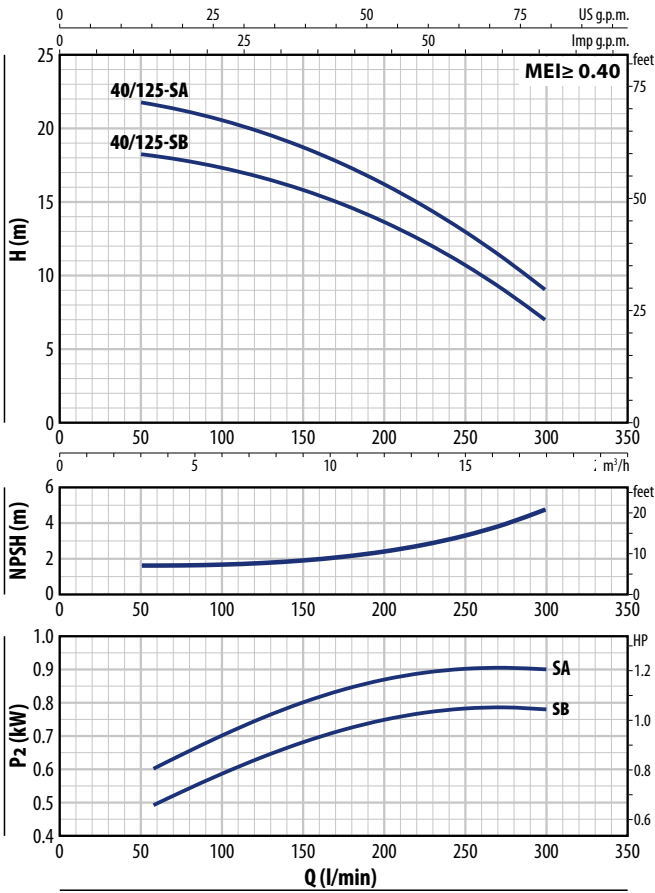

WR 50/125

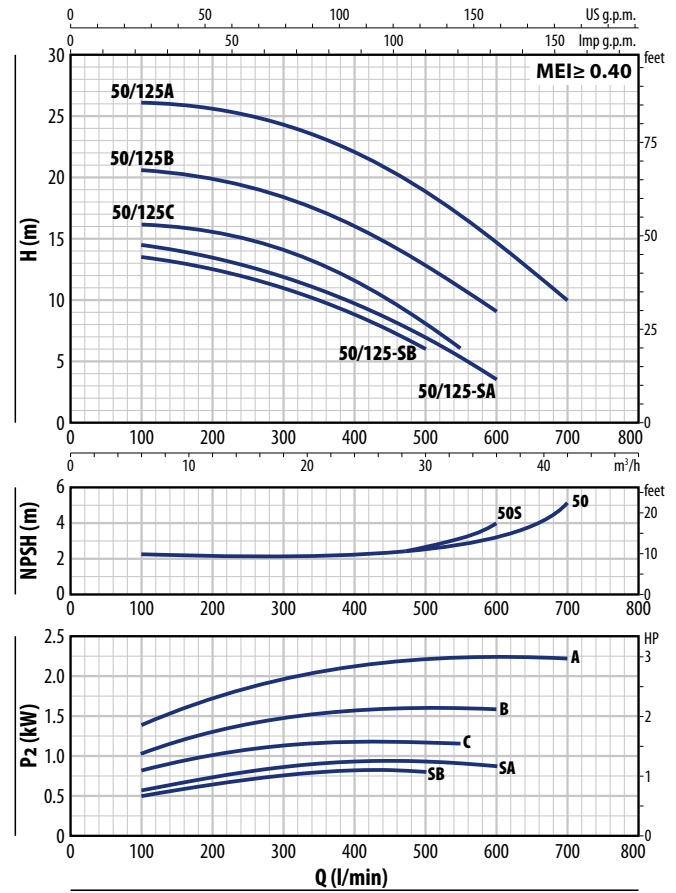

WR 40/125

TYPE		POWER (P ₂)		1~3~	Q	m ³ /h									
Single-phase	Three-phase	kW	HP			0	3	6	9	12	15	18			
WRm 40/125-SB	WR 40/125-SB	0.55	0.75	IE2 IE3	H metres	0	50	100	150	200	250	300			
WRm 40/125-SA	WR 40/125-SA	0.75	1			18.7	18.2	17.3	15.8	13.7	10.7	7			
						22.4	21.8	20.6	18.7	16.2	13	9			

WR 50/125

TYPE		POWER (P ₂)		1~3~	Q	m ³ /h												
Single-phase	Three-phase	kW	HP			0	6	12	18	24	30	33	36	39	42			
WRm 50/125-SB	WR 50/125-SB	0.55	0.75	IE2 IE3	H metres	0	100	200	300	400	500	550	600	650	700			
WRm 50/125-SA	WR 50/125-SA	0.75	1			14	13.5	12.5	11	8.8	6							
WRm 50/125C	WR 50/125C	1.1	1.5			15	14.5	13.5	11.8	9.7	7	5.5	3.5					
WRm 50/125B	WR 50/125B	1.5	2			16	16	15.5	14	11.5	8	6						
WRm 50/125A	WR 50/125A	2.2	3			20.5	20.5	19.8	18.5	16	12.8	11	9					
						26	26	25.5	24	22	18.5	17	14.5	12.5	10			

Q = Flow rate H = Total manometric head HS = Suction height

Performance curves comply with EN ISO 9906 Grade 3B tolerance limits.

ABSORPTION

TYPE	VOLTAGE
Single-phase	230 V
WR 40/125-SB	5.2 A
WR 40/125-SA	6.0 A
WR 50/125-SB	5.2 A
WR 50/125-SA	6.0 A
WR 50/125C	8.0 A
WR 50/125B	10.0 A
WR 50/125A	13.5 A

TYPE	VOLTAGE	
	230 V - Δ	400 V - Y
Three-phase		
WR 40/125-SB	3.6 A	2.1 A
WR 40/125-SA	4.0 A	2.3 A
WR 50/125-SB	3.6 A	2.1 A
WR 50/125-SA	4.0 A	2.3 A
WR 50/125C	5.2 A	3.0 A
WR 50/125B	7.8 A	4.5 A
WR 50/125A	9.0 A	5.2 A

DIMENSIONS

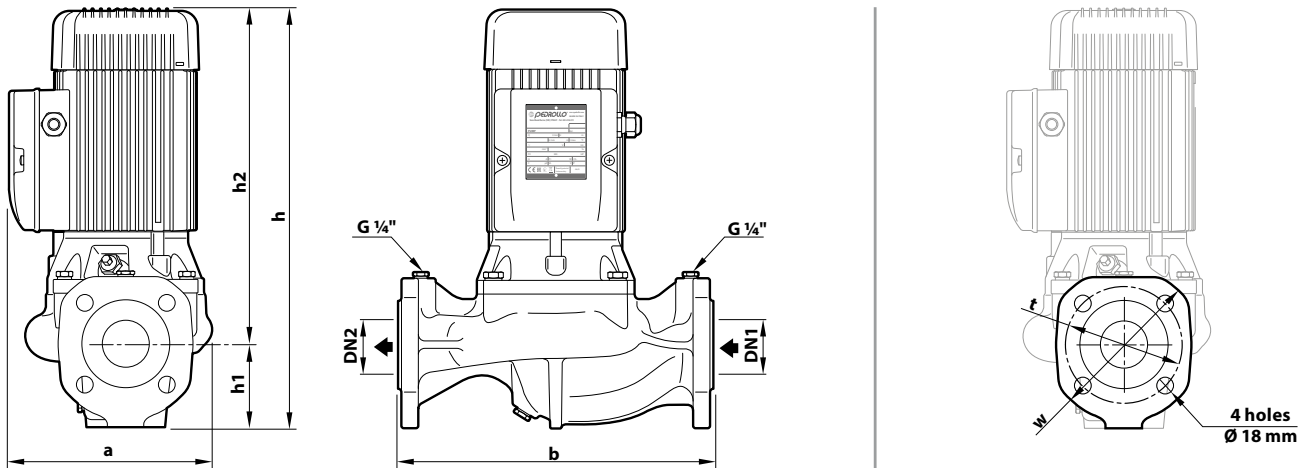

TYPE		PORTS		DIMENSIONS mm							kg
Single-phase	Three-phase	DN1	DN2	a	b	h	h1	h2	w	t	
WRm 40/125-SB	WR 40/125-SB	DN 40	DN 40	195	320	350	81	269	150	110	21.1
WRm 40/125-SA	WR 40/125-SA										
WRm 50/125-SB	WR 50/125-SB	DN 50	DN 50		340	362	90	272	165	125	23.4
WRm 50/125-SA	WR 50/125-SA										
WRm 50/125C	WR 50/125C			220	340	432	90	342	165	125	30.0
WRm 50/125B	WR 50/125B										
-	WR 50/125A					452		362			32.0

MATERIALS AND COMPONENTS

1 Pump body Cast iron with cataphoresis treatment, provided with flanged ports

2 Cover Cast iron with cataphoresis treatment

3 Impeller Stainless steel **AISI 304**

4 Shaft Stainless steel **AISI 431**

5 Mechanical seal

Water pump	Seal	Shaft	Materials
WR 40/125-S	FNC-14	Ø 14 mm	Graphite / Ceramic / EPDM
WR 50/125-S			
WR 50/125	FN-20	Ø 20 mm	Graphite / Ceramic / EPDM

6 Electric motor

WRm: single-phase 230 V - 50 Hz with capacitor and winding integrated thermal motor protection

WR: three-phase 230/400 V - 50 Hz

※ Pumps are equipped with high-efficiency motors (IEC 60034-30-1) class **IE2** for single-phase models class **IE3** for three-phase models

Continuous running duty **S1**

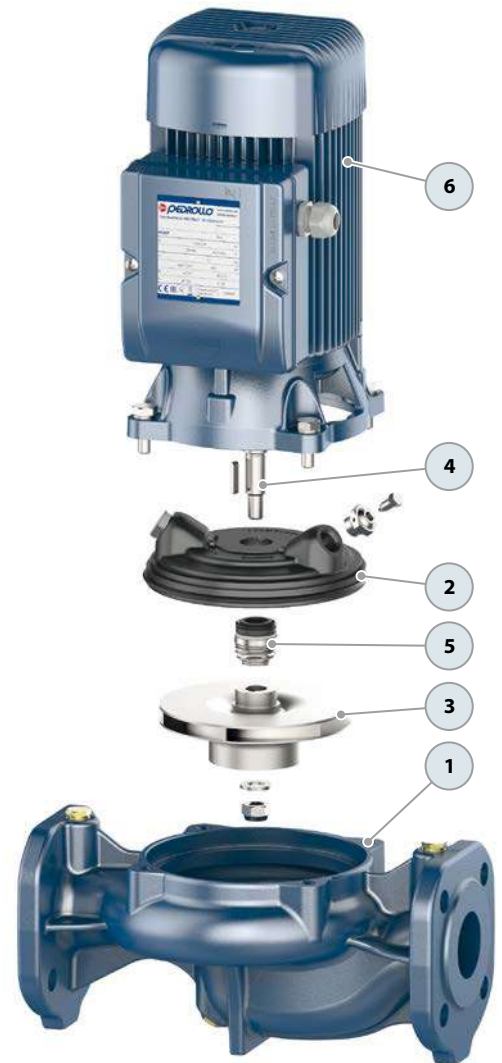

-  Clean water
-  Civil use
-  Industrial use



PERFORMANCE RANGE

- Flow rate up to **5750 l/min** (345 m³/h)
- Head up to **98 m**
- Power from **1.5 to 75 kW**

INSTALLATION AND USE

Close-coupled centrifugal electric pumps with flanges constructed according to the EN733 standard.

- For clean water free from abrasive particles and liquids that will not damage the pump's components
- Water supply
- Pressurization
- Irrigation
- Water circulation in air conditioning systems
- Power washing systems
- Firefighting systems
- Industrial applications
- Agriculture applications

Installation should be carried out in well-ventilated indoor or protected areas.

ELECTRIC MOTOR

The three-phase pumps are equipped with newly developed electric motors designed to work with inverters, which guarantee stable and quiet operation.

Efficiency class **IE3** for three-phase motors, **IE2** for single-phase motors, class F insulation and IP55 protection.

APPLICATION LIMITS

- Manometric suction head up to **7 m**
- Liquid temperature between **-10 °C** and **+90 °C**
- Ambient temperature between **-10 °C** and **+40 °C**
- Maximum pressure in the pump body **10 bar** (PN10)

AVAILABLE UPON REQUEST

- ✘ Mechanical seal options available
- ✘ Different voltage requirements 60 Hz frequency
- ✘ Handling of liquids with higher or lower temperatures
- ✘ Adaptability to operate in high or low temperature environments
- ✘ Counterflange KIT including screws, nuts and gaskets



PERFORMANCE RANGE - n= 2900 min⁻¹

50 Hz

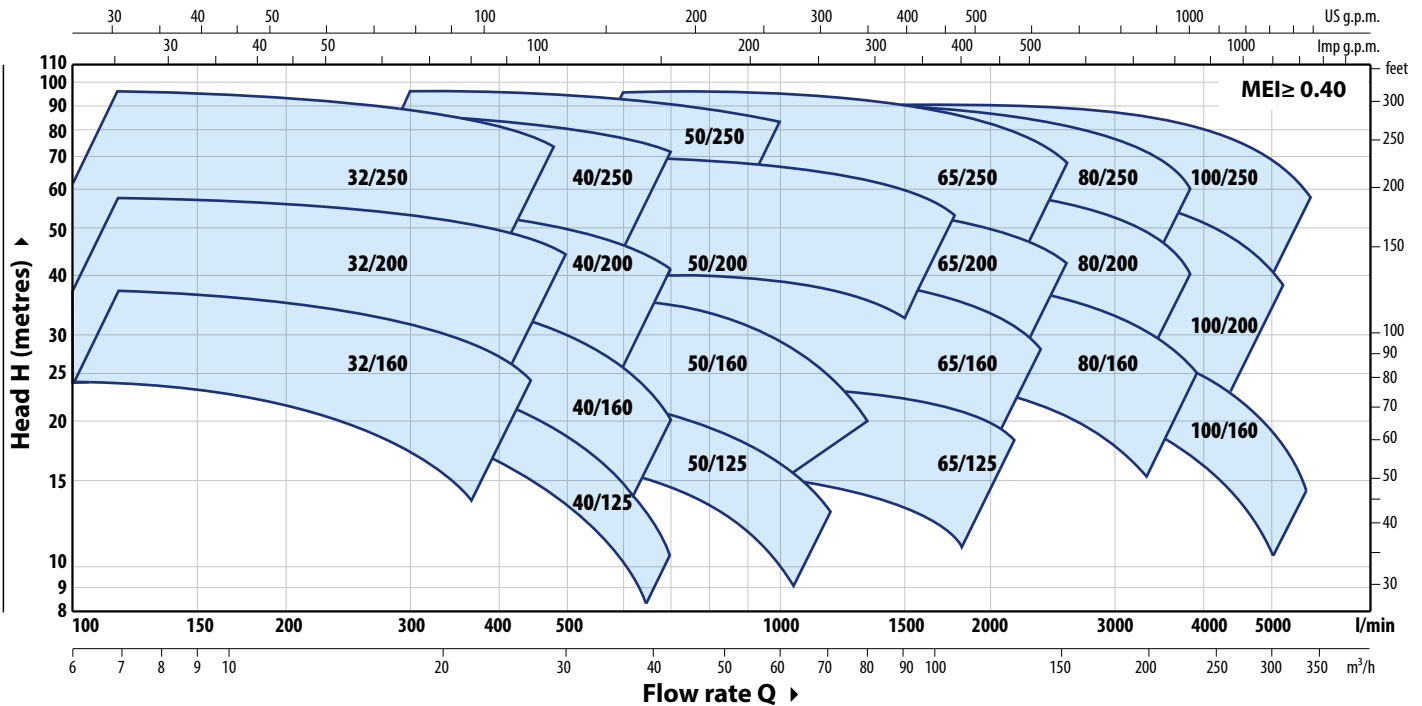

PERFORMANCE DATA - n= 2900 min⁻¹

50 Hz

TYPE	POWER (P ₂)		PERFORMANCE	
	kW	HP	Q l/min	H metres
F 32/160C	1.5	2	100 – 350	24 – 14
F 32/160B	2.2	3	100 – 400	30 – 17
F 32/160A	3	4	100 – 450	37 – 24
F 32/200C	4	5.5	100 – 450	44 – 31.5
F 32/200B	5.5	7.5	100 – 500	51 – 36
F 32/200A	7.5	10	100 – 500	57 – 44
F 32/200BH	3	4	100 – 300	45 – 37
F 32/200AH	4	5.5	100 – 320	55 – 44
F 32/250C	9.2	12.5	100 – 450	75 – 60
F 32/250B	11	15	100 – 500	87 – 70
F 32/250A	15	20	100 – 500	97 – 80
F 40/125C	1.1	1.5	100 – 550	16 – 6
F 40/125B	1.5	2	100 – 600	20.5 – 9
F 40/125A	2.2	3	100 – 700	26 – 10
F 40/160C	2.2	3	100 – 600	27 – 14
F 40/160B	3	4	100 – 600	32 – 20
F 40/160A	4	5.5	100 – 700	38 – 20
F 40/200B	5.5	7.5	100 – 700	47 – 28
F 40/200A	7.5	10	100 – 700	55 – 41
F 40/250C	9.2	12.5	100 – 700	64 – 47
F 40/250B	11	15	100 – 700	71 – 55
F 40/250A	15	20	100 – 700	88 – 72
F 50/125C	2.2	3	300 – 1200	17.5 – 6
F 50/125B	3	4	300 – 1200	20.7 – 9
F 50/125A	4	5.5	300 – 1200	23.5 – 13
F 50/160C	4	5.5	300 – 1000	27 – 16
F 50/160B	5.5	7.5	300 – 1200	32 – 18
F 50/160A	7.5	10	300 – 1350	37.5 – 20
F 50/200C	11	15	400 – 1700	44 – 30
F 50/200B	15	20	400 – 1700	52 – 38
F 50/200A	18.5	25	400 – 1800	61 – 45
F 50/200AR	22	30	400 – 1800	69 – 53

TYPE	POWER (P ₂)		PERFORMANCE	
	kW	HP	Q l/min	H metres
F 50/250D	9.2	12.5	300 – 900	51 – 32
F 50/250C	11	15	300 – 1000	59 – 43
F 50/250B	15	20	300 – 1000	72 – 59
F 50/250A	18.5	25	300 – 1000	85 – 73
F 50/250AR	22	30	300 – 1000	95 – 83
F 65/125C	4	5.5	600 – 1800	16 – 11
F 65/125B	5.5	7.5	600 – 2000	18 – 13
F 65/125A	7.5	10	600 – 2200	23 – 18
F 65/160C	9.2	12.5	600 – 2200	32 – 22
F 65/160B	11	15	600 – 2400	36.5 – 23
F 65/160A	15	20	600 – 2400	40.5 – 28
F 65/200B	15	20	200 – 2400	44 – 30.5
F 65/200A	18.5	25	200 – 2500	50 – 36.5
F 65/200AR	22	30	200 – 2600	57 – 42
F 65/250C	30	40	400 – 2350	76 – 53
F 65/250B	37	50	400 – 2500	87 – 62
F 65/250A	45	60	400 – 2600	95 – 68
F 80/160D	11	15	500 – 4000	25 – 10
F 80/160C	15	20	500 – 4000	30 – 15
F 80/160B	18.5	25	500 – 4000	35 – 20
F 80/160A	22	30	500 – 4000	40 – 25
F 80/200B	30	40	500 – 3650	56 – 34.5
F 80/200A	37	50	500 – 3900	62 – 40
F 80/250B	45	60	600 – 3600	77 – 54
F 80/250A	55	75	600 – 3900	88.5 – 60
F 100/160C	15	20	1000 – 5000	30 – 12
F 100/160B	18.5	25	1000 – 5200	34 – 14.5
F 100/160A	22	30	1000 – 5500	38 – 17.5
F 100/200C	30	40	833 – 4650	51 – 28
F 100/200B	37	50	833 – 4900	57 – 33
F 100/200A	45	60	833 – 5250	63 – 38
F 100/250B	55	75	800 – 5150	75 – 48
F 100/250A	75	100	800 – 5750	89 – 58

F 32

CURVES AND PERFORMANCE DATA – HS=0 m

50 Hz

F 32/160

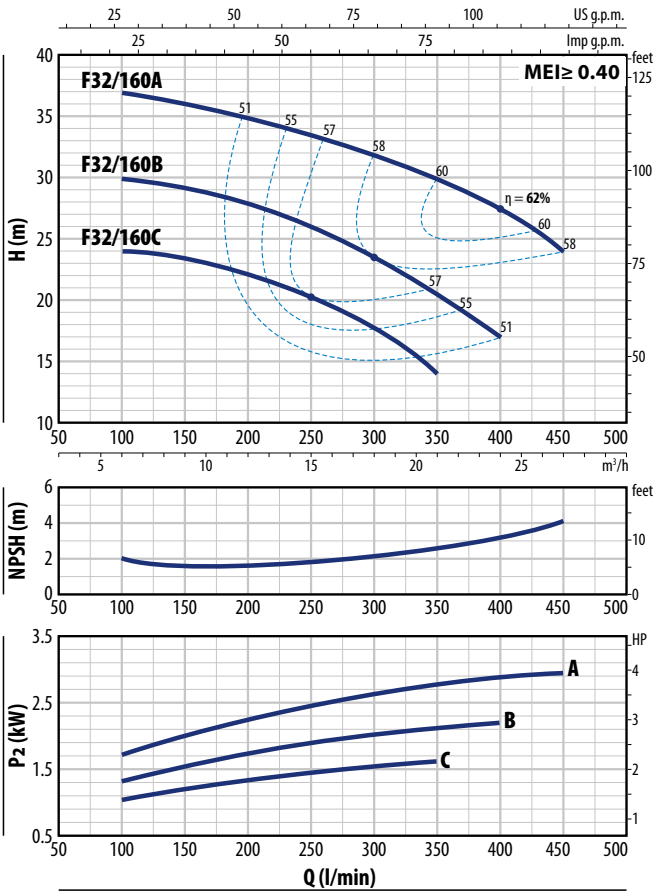

F 32/200

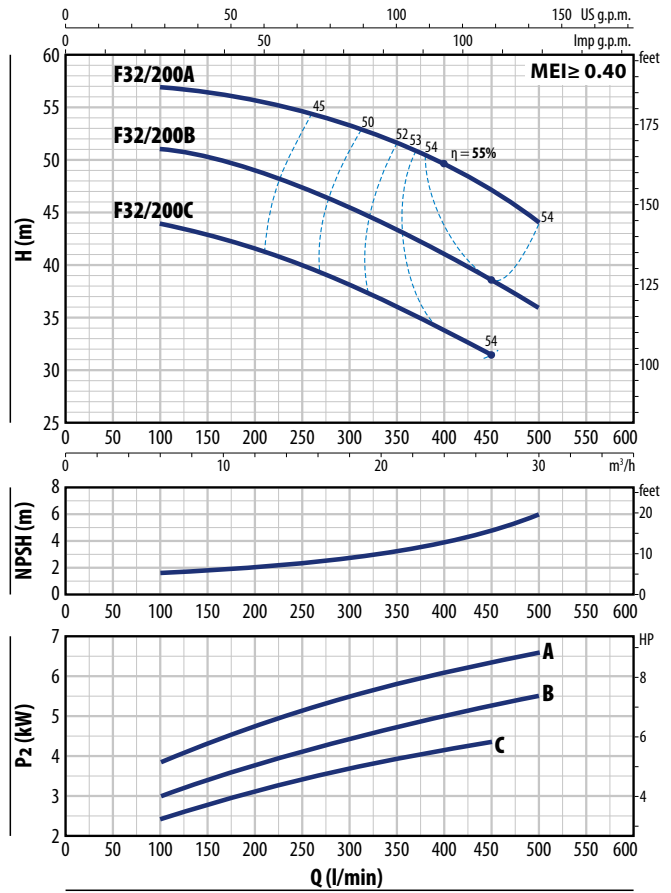

F 32/160

TYPE		POWER (P ₂)		1~3~	Q	m ³ /h												
Single-ph.	Three-ph.	kW	HP			l/min	0	6	9	12	15	18	21	24	27			
Fm 32/160C	F 32/160C	1.5	2	IE2 IE3	H metres	0	100	150	200	250	300	350	400	450				
Fm 32/160B	F 32/160B	2.2	3			25	24	23.5	22	20.5	18	14						
-	F 32/160A	3	4			31	30	29	28	26	23.5	20.5	17					
						38	37	36	35	33.5	31.5	30	27.5	24				

F 32/200

TYPE		POWER (P ₂)		3~	Q	m ³ /h												
Three-ph.		kW	HP			l/min	0	6	9	12	15	18	21	24	27	30		
F 32/200C		4	5.5	IE3	H metres	0	100	150	200	250	300	350	400	450	500			
F 32/200B		5.5	7.5			46	44	43	41.5	40	38	36	34	31.5				
F 32/200A		7.5	10			52	51	50.5	49	47	45	43	41	38.5	36			
						60	57	56.5	56	55	53.5	52	50	47	44			

Q = Flow rate H = Total manometric head HS = Suction height

Performance curves comply with EN ISO 9906 Grade 3B tolerance limits.

CURVES AND PERFORMANCE DATA – HS=0 m

50 Hz

F 32/200H

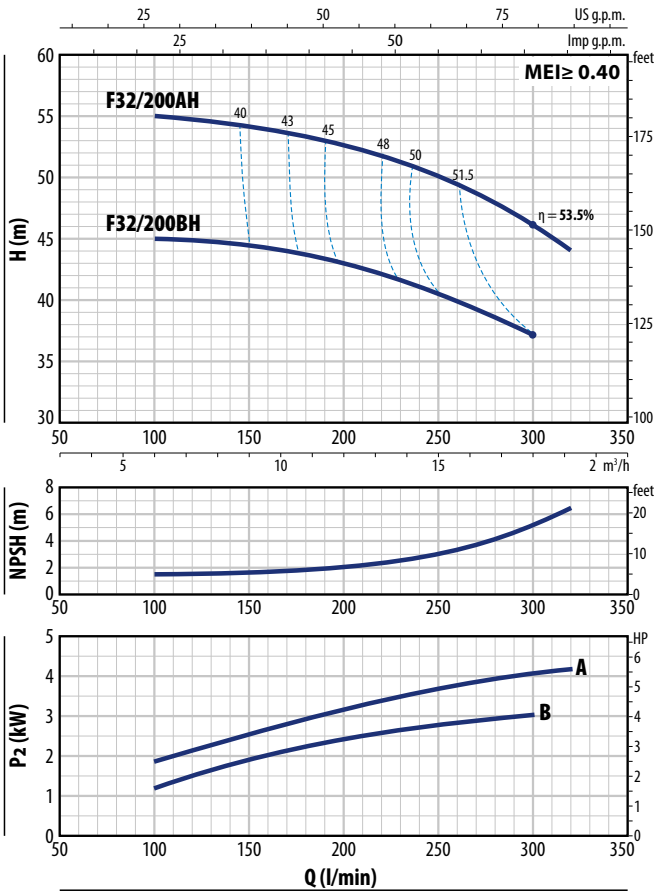

F 32/250

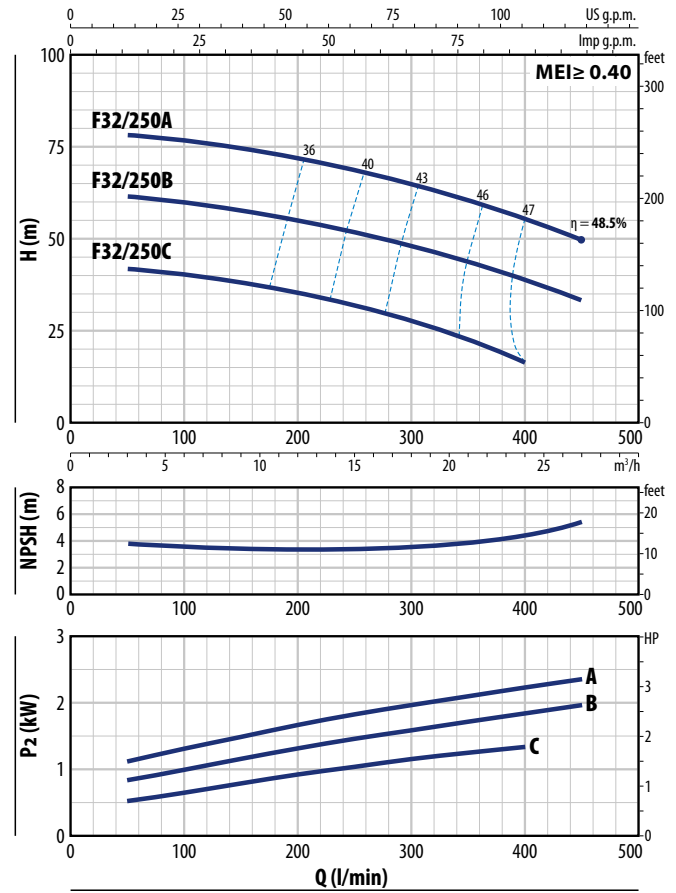

F 32/200H

TYPE	POWER (P ₂)		3~	Q	Q							
	kW	HP			m ³ /h	0	6	9	12	15	18	19.2
Three-phase				l/min	0	100	150	200	250	300	320	
F 32/200BH	3	4	IE3	H metres	47	45	44.5	43	40.5	37		
F 32/200AH	4	5.5			57	55	54	52.5	50	46	44	

F 32/250

TYPE	POWER (P ₂)		3~	Q	Q									
	kW	HP			m ³ /h	0	6	9	12	15	18	21	24	27
Three-phase				l/min	0	100	150	200	250	300	350	400	450	500
F 32/250C	9.2	12.5	IE3	H metres	76	75	74.5	73	71.5	69.5	67	64	60	
F 32/250B	11	15			88	87	86	85	83	81	79	76.5	73.5	70
F 32/250A	15	20			98	97	96	95	93	91	89	86.5	83.5	80

Q = Flow rate H = Total manometric head HS = Suction height

Performance curves comply with EN ISO 9906 Grade 3B tolerance limits.

F 40

CURVES AND PERFORMANCE DATA – HS=0 m

50 Hz

F 40/125

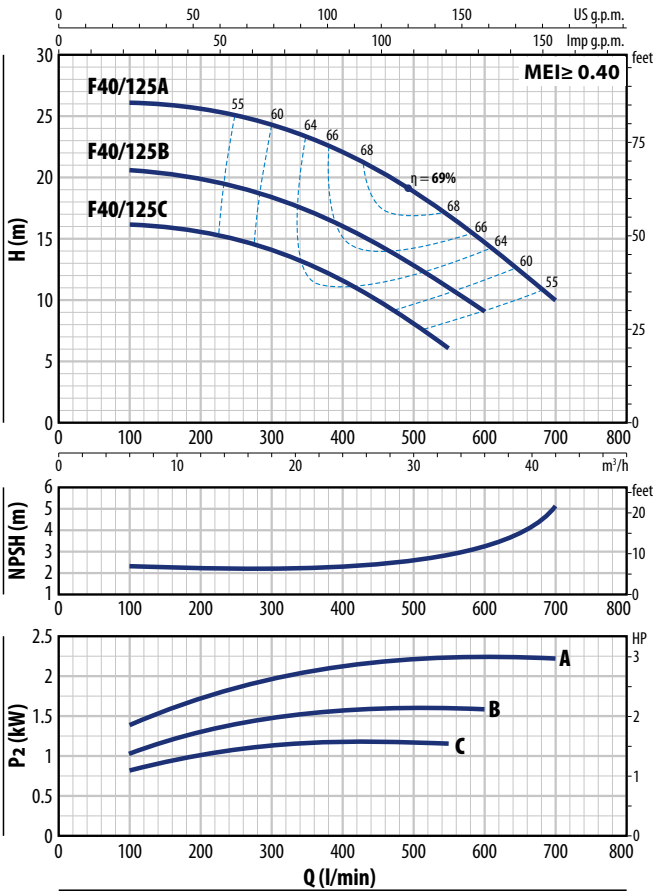

F 40/160

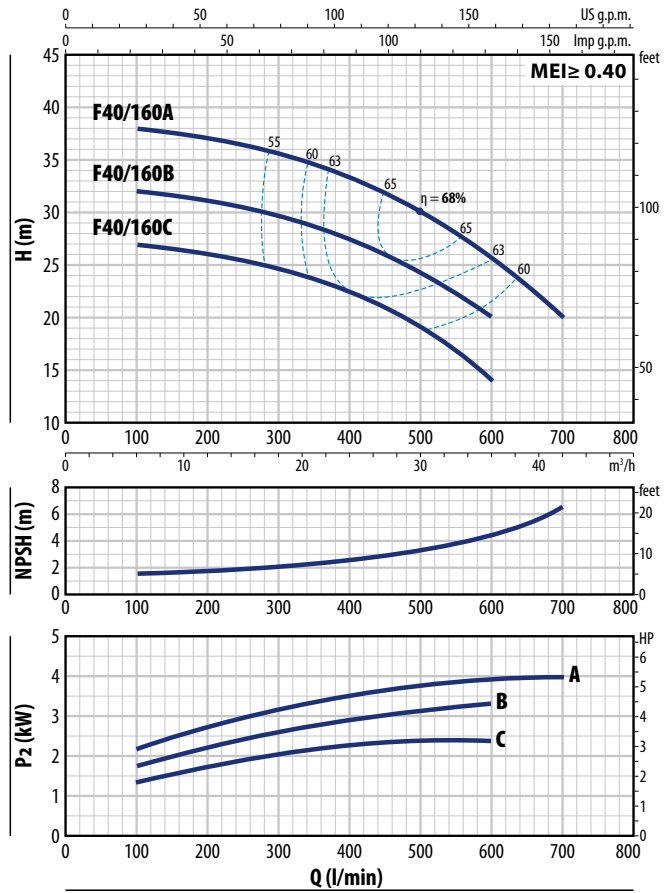

F 40/125

TYPE		POWER (P ₂)		1~3~	Q	m ³ /h									
Single-phase	Three-phase	kW	HP			0	6	12	18	24	30	33	36	39	42
Fm 40/125C	F 40/125C	1.1	1.5		0	100	200	300	400	500	550	600	650	700	
Fm 40/125B	F 40/125B	1.5	2	IE2 IE3	H metres	20.5	20.5	19.8	18.5	16	12.8	11	9		
-	F 40/125A	2.2	3			26	26	25.5	24	22	18.5	17	14.5	12.5	10

F 40/160

TYPE		POWER (P ₂)		1~3~	Q	m ³ /h									
Single-phase	Three-phase	kW	HP			0	6	9	12	15	18	24	30	36	42
Fm 40/160C	F 40/160C	2.2	3			27	27	26.5	26	25.5	25	22.5	19	14	
-	F 40/160B	3	4	IE2 IE3	H metres	32	32	31.5	31	30.5	30	27.5	24	20	
-	F 40/160A	4	5.5			38	38	37.8	37	36.5	36	33.5	30	26	20

Q = Flow rate H = Total manometric head HS = Suction height

Performance curves comply with EN ISO 9906 Grade 3B tolerance limits.

CURVES AND PERFORMANCE DATA – HS=0 m

50 Hz

F 40/200

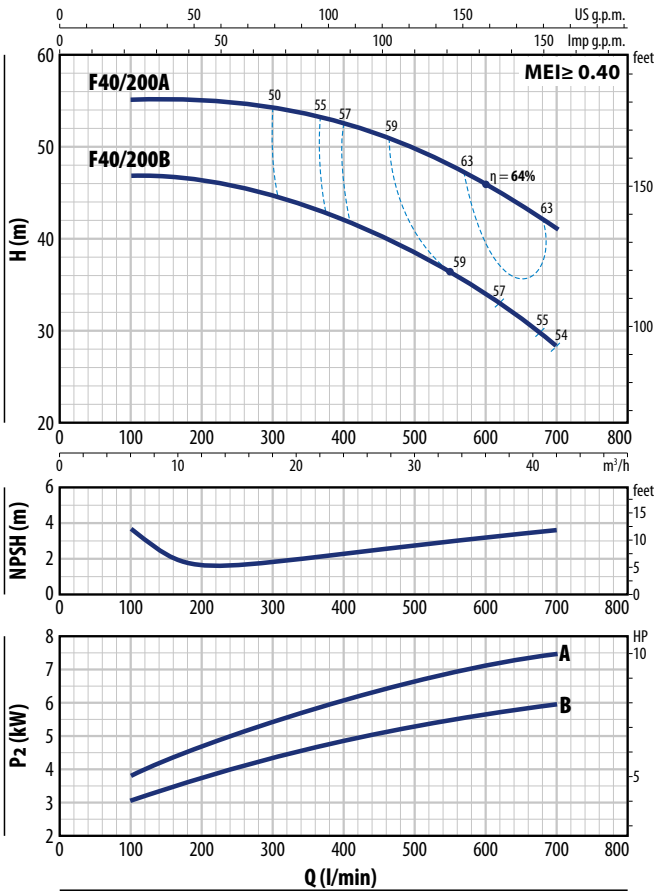

F 40/250

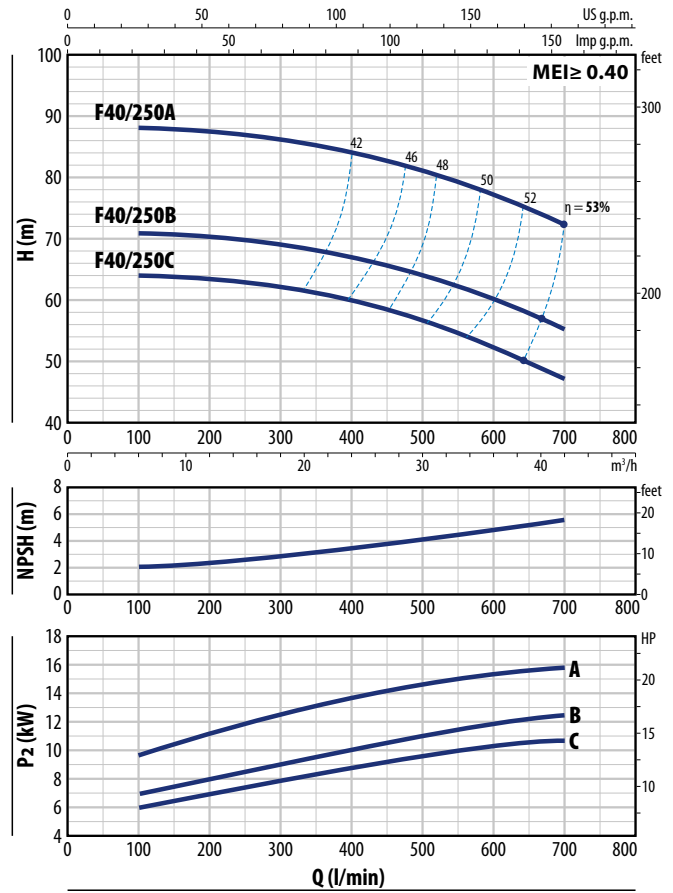

F 40/200

TYPE	POWER (P ₂)		3~	Q	m ³ /h													
	kW	HP			0	6	9	12	15	18	24	30	36	42				
Three-phase				l/min	0	100	150	200	250	300	400	500	600	700				
F 40/200B	5.5	7.5	IE3	H metres	48	47	46.5	46	45.5	44.5	42	38	34	28				
F 40/200A	7.5	10			56	55	55	55	54.5	54	52.5	49.5	46	41				

F 40/250

TYPE	POWER (P ₂)		3~	Q	m ³ /h													
	kW	HP			0	6	9	12	15	18	24	30	36	42				
Three-phase				l/min	0	100	150	200	250	300	400	500	600	700				
F 40/250C	9.2	12.5	IE3	H metres	64	64	63.5	63	62.5	62	60	56.5	52.5	47				
F 40/250B	11	15			71	71	70.5	70	69.5	69	67	64	60	55				
F 40/250A	15	20			88	88	87.5	87	86.5	86	84	81	77	72				

Q = Flow rate H = Total manometric head HS = Suction height

Performance curves comply with EN ISO 9906 Grade 3B tolerance limits.

F 50

CURVES AND PERFORMANCE DATA – HS=0 m

50 Hz

F 50/125

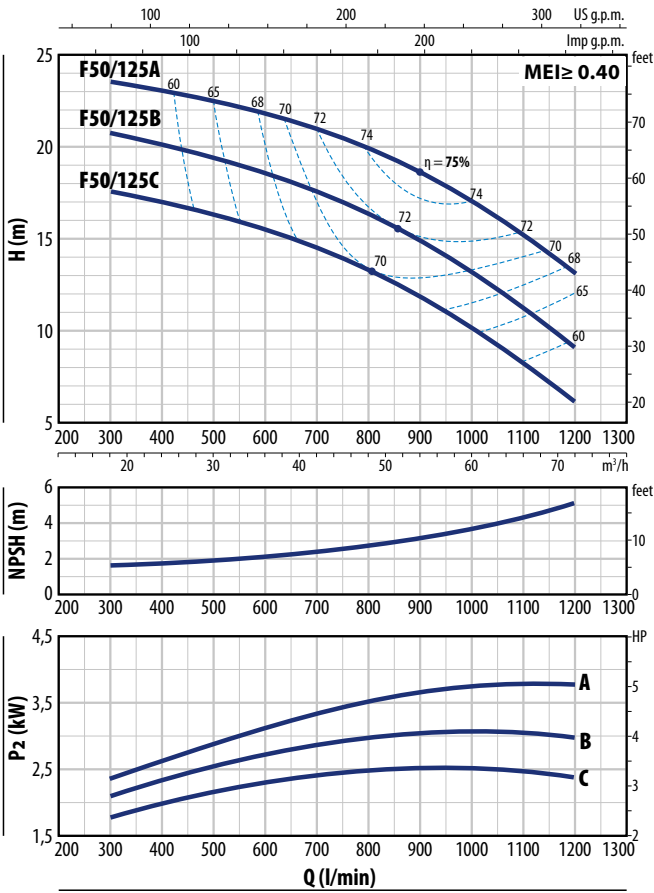

F 50/160

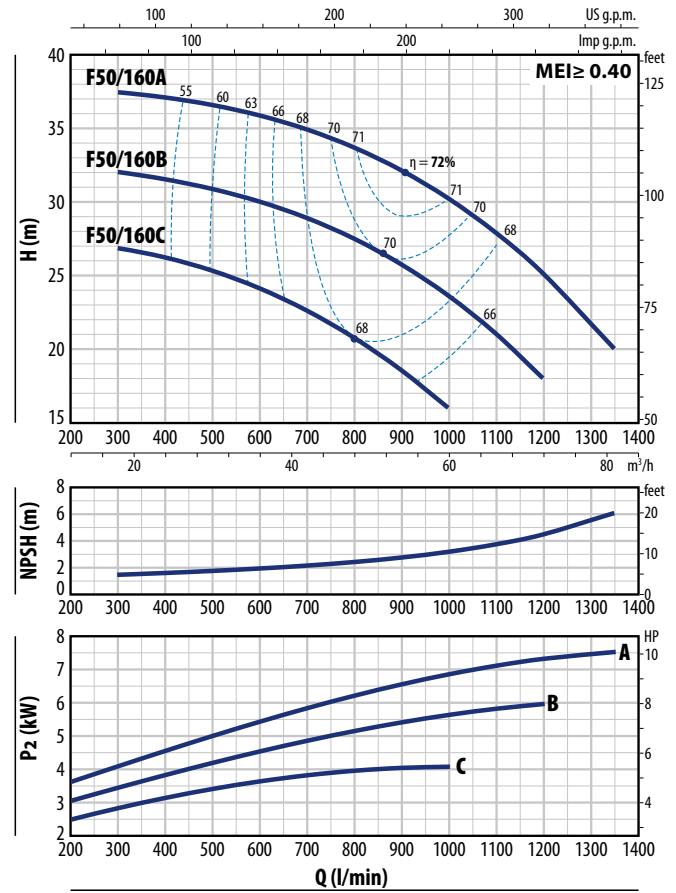

F 50/125

TYPE		POWER (P ₂)		1~	3~	Q	m ³ /h												
Single-ph.	Three-ph.	kW	HP				0	18	24	30	36	42	48	54	60	66	72		
Fm 50/125C	F 50/125C	2.2	3	IE2	IE3	H metres	0	300	400	500	600	700	800	900	1000	1100	1200		
-	F 50/125B	3	4				18.5	17.5	17	16.5	15.5	14.8	13.5	12	10.5	8.2	6		
-	F 50/125A	4	5.5				21.5	20.7	20	19.5	18.8	17.8	16.5	15	13.5	11.2	9		
							24.5	23.5	23	22.5	21.8	20.8	19.5	18.3	16.8	15	13		

F 50/160

TYPE		POWER (P ₂)		3~	Q	m ³ /h												
Three-phase		kW	HP			0	18	24	30	36	42	48	54	60	66	72	81	
F 50/160C		4	5.5	IE3	H metres	0	300	400	500	600	700	800	900	1000	1100	1200	1350	
F 50/160B		5.5	7.5			27	27	26.5	25	24.5	23	20	18.5	16				
F 50/160A		7.5	10			33	32	31.7	31	30	29	27.4	25.7	23.5	21	18		
							38	37.5	37	36.5	36	35	33.7	32	30.2	28	25	20

Q = Flow rate H = Total manometric head HS = Suction height

Performance curves comply with EN ISO 9906 Grade 3B tolerance limits.

CURVES AND PERFORMANCE DATA – HS=0 m

50 Hz

F 50/200

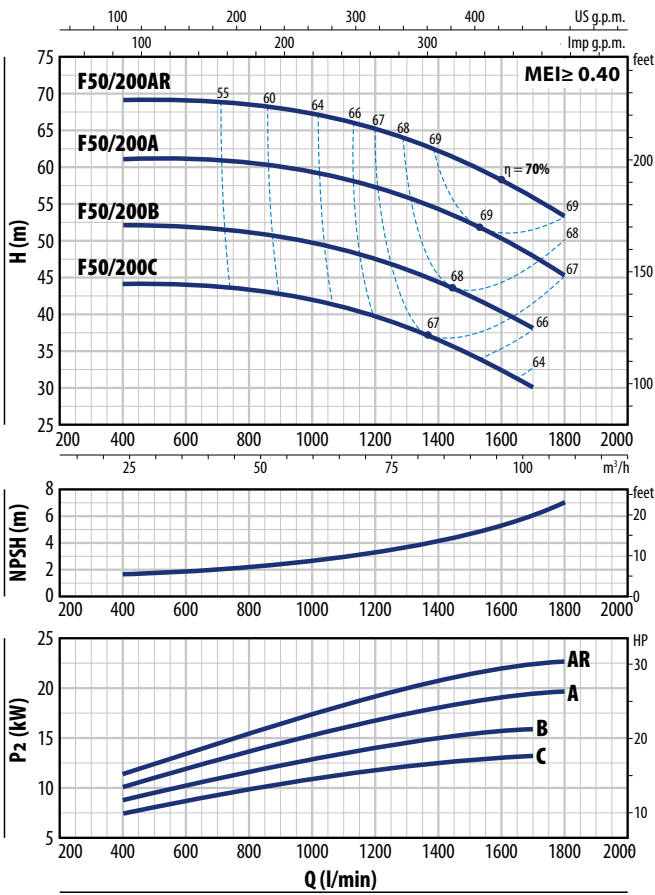

F 50/250

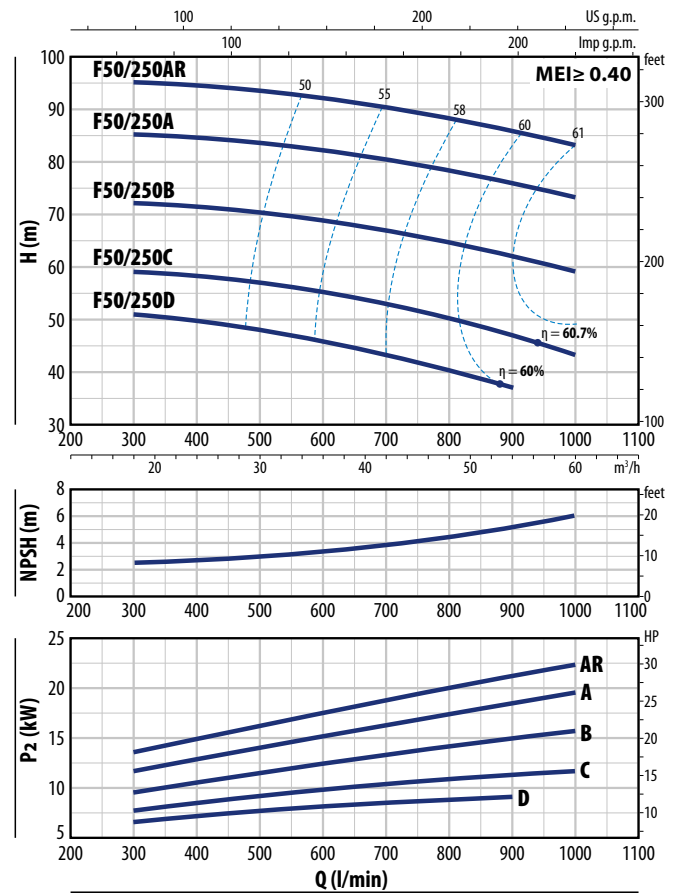

F 50/200

TYPE	POWER (P ₂)		3~	Q	Q												
	kW	HP			m ³ /h	24	36	48	60	72	84	96	102	108			
Three-phase				l/min	400	600	800	1000	1200	1400	1600	1700	1800				
F 50/200C	11	15	IE3	H metres	44	44	44	42	39	36	33	30					
F 50/200B	15	20			52	52	52	50	47	44	40	38					
F 50/200A	18.5	25			61	61	60.5	60	57	54	50	48	45				
F 50/200AR	22	30			69	69	68.5	68	65	62	58	56	53				

F 50/250

TYPE	POWER (P ₂)		3~	Q	Q												
	kW	HP			m ³ /h	0	18	24	30	36	42	48	54	60			
Three-phase				l/min	0	300	400	500	600	700	800	900	1000				
F 50/250D	9.2	12.5	IE3	H metres	51	50.5	49.5	48	45.5	43	40	37					
F 50/250C	11	15			59	59	58	56.5	55	53	50	47	43				
F 50/250B	15	20			72	72	71	70	69	67	65	62	59				
F 50/250A	18.5	25			85	85	84	83	82	80	78	76	73				
F 50/250AR	22	30			95	95	94	93	92	90	88	86	83				

Q = Flow rate H = Total manometric head HS = Suction height

Performance curves comply with EN ISO 9906 Grade 3B tolerance limits.

F 65

CURVES AND PERFORMANCE DATA – HS=0 m

50 Hz

F 65/125

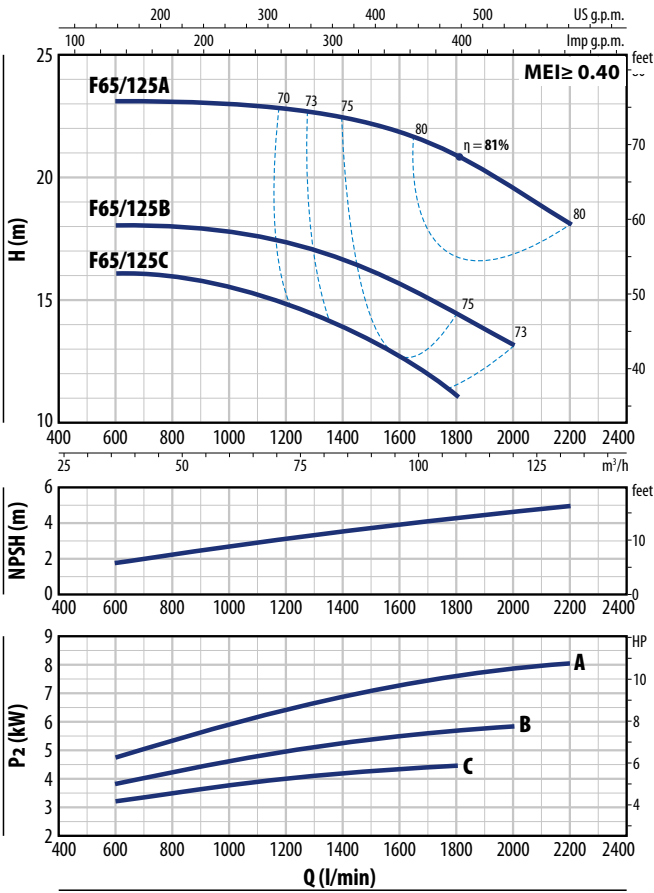

F 65/160

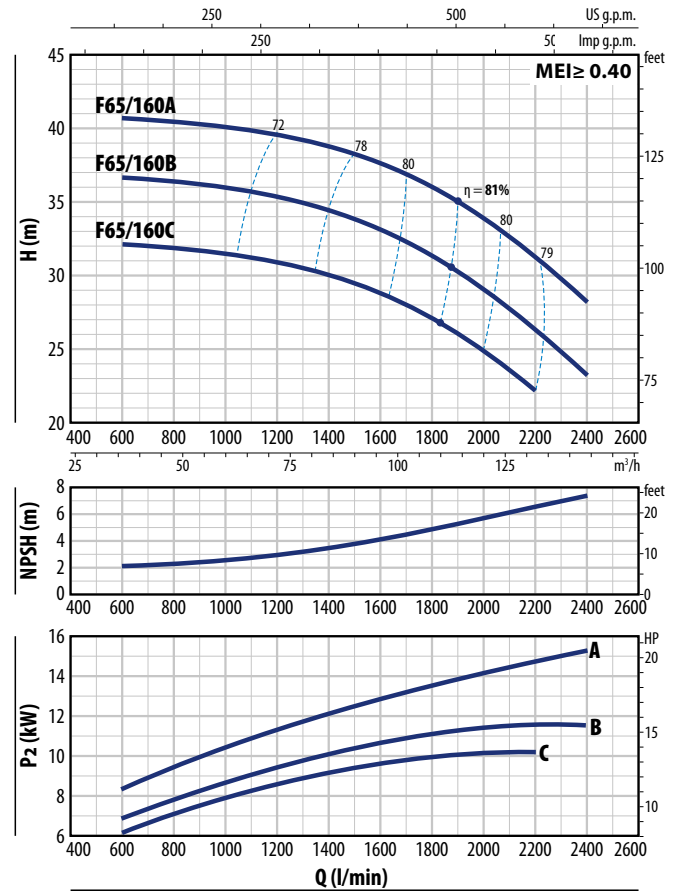

F 65/125

TYPE	POWER (P ₂)		3~	Q	m ³ /h												
	kW	HP			0	36	48	60	72	84	96	108	120	132			
Three-phase				l/min	0	600	800	1000	1200	1400	1600	1800	2000	2200			
F 65/125C	4	5.5	IE3	H metres	16	16	16	15.5	14.5	13.5	12.5	11					
F 65/125B	5.5	7.5			18	18	18	18	17	16.5	15.5	14.5	13				
F 65/125A	7.5	10			23	23	23	23	22.5	22.5	22	21	19.5	18			

F 65/160

TYPE	POWER (P ₂)		3~	Q	m ³ /h												
	kW	HP			0	36	48	60	72	84	96	108	120	132	144		
Three-phase				l/min	0	600	800	1000	1200	1400	1600	1800	2000	2200	2400		
F 65/160C	9.2	12.5	IE3	H metres	32	32	32	32	32	30	29	27	25	22			
F 65/160B	11	15			37	36.5	36.5	36	35.5	34	33	31	29	26	23		
F 65/160A	15	20			41	40.5	40.5	40	39.5	39	37.5	36	34	31	28		

Q = Flow rate H = Total manometric head HS = Suction height

Performance curves comply with EN ISO 9906 Grade 3B tolerance limits.

CURVES AND PERFORMANCE DATA – HS=0 m

50 Hz

F 65/200

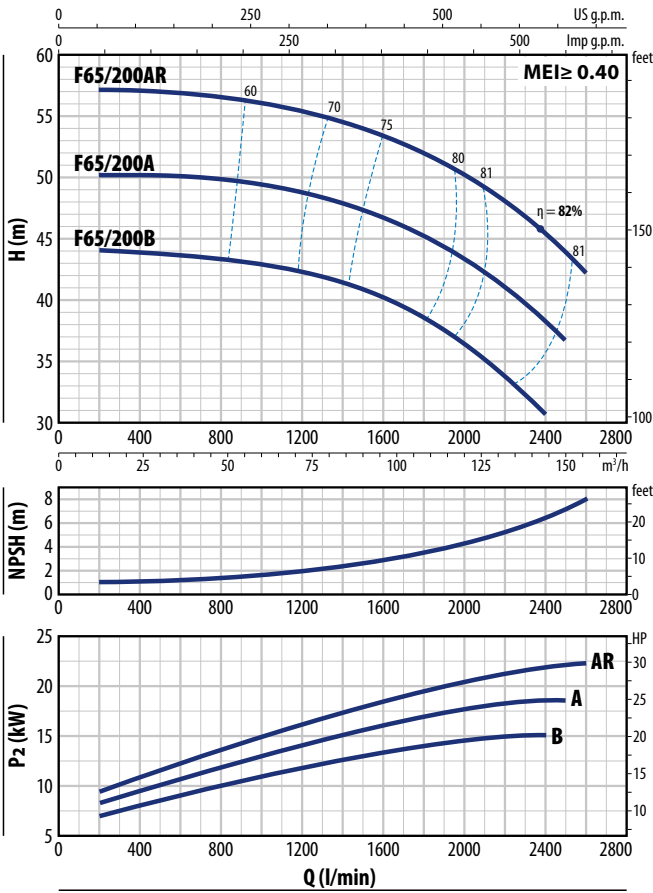

F 65/250

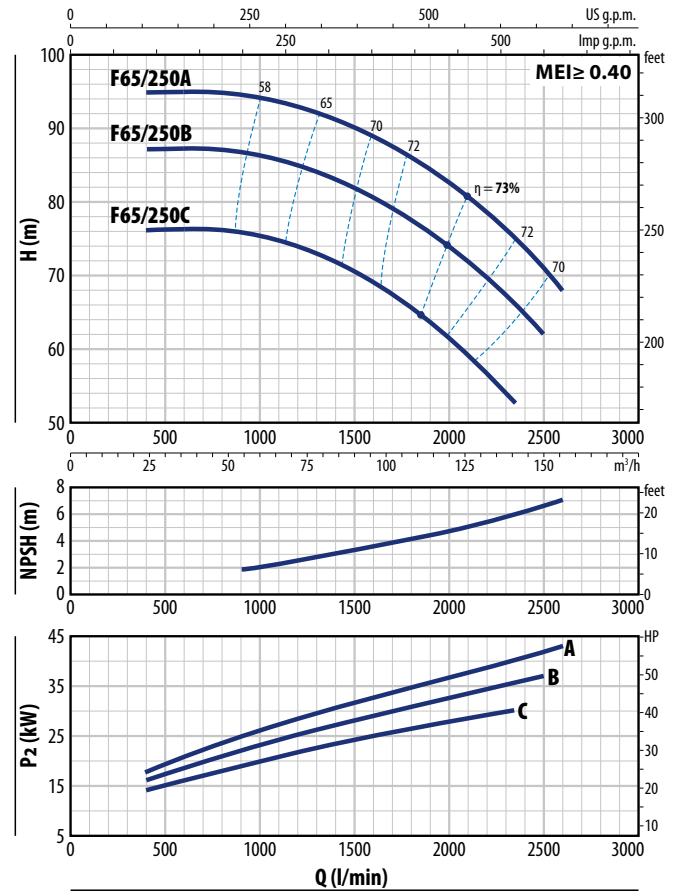

F 65/200

TYPE	POWER (P ₂)		3~	Q	m ³ /h														
	kW	HP			12	36	48	60	72	84	96	108	120	132	144	150	156		
Three-phase				l/min	200	600	800	1000	1200	1400	1600	1800	2000	2200	2400	2500	2600		
F 65/200B	15	20	IE3	H metres	44	43.5	43.3	43	42.5	41.5	40	38.5	36.5	34	30.5				
F 65/200A	18.5	25			50	50	50	49.5	49	48	46.5	45	43	41	38	36.5			
F 65/200AR	22	30			57	57	57	56	55.5	54.5	53.5	52	50	48	45.5	43.5	42		

F 65/250

TYPE	POWER (P ₂)		3~	Q	m ³ /h									
	kW	HP			24	40	60	80	100	120	141	150	156	
Three-phase				l/min	400	667	1000	1333	1667	2000	2350	2500	2600	
F 65/250C	30	40	IE3	H metres	76	76	75.5	72.5	68	61.5	53			
F 65/250B	37	50			87	87	86	84	80	74	66.5	62		
F 65/250A	45	60			95	95	94	92	88	82.5	75	71	68	

Q = Flow rate H = Total manometric head HS = Suction height

Performance curves comply with EN ISO 9906 Grade 3B tolerance limits.

F 80

CURVES AND PERFORMANCE DATA – HS=0 m

50 Hz

F 80/160

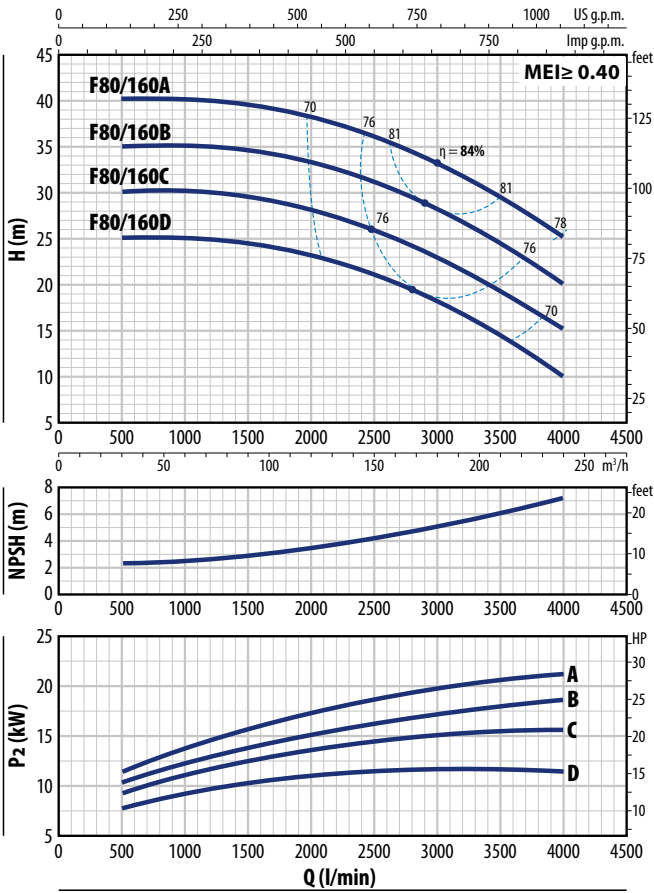

F 80/200

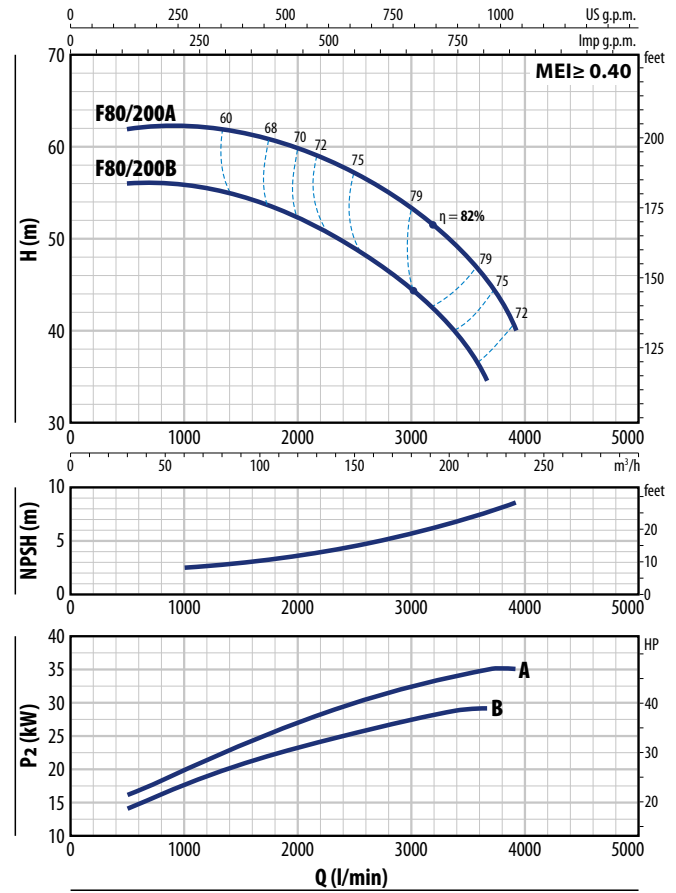

F 80/160

TYPE	POWER (P ₂)		3~	Q	m ³ /h											
	kW	HP			0	30	60	90	120	150	180	210	240			
Three-phase					0	500	1000	1500	2000	2500	3000	3500	4000			
F 80/160D	11	15	IE3	H metres	25	25	25	24.5	23.5	21	18	14.5	10			
F 80/160C	15	20			30	30	30	29.5	28.5	26	23	19.5	15			
F 80/160B	18.5	25			35	35	35	34.5	33.5	31	28.5	24.5	20			
F 80/160A	22	30			40	40	40	39.5	38.5	36	33	29.5	25			

F 80/200

TYPE	POWER (P ₂)		3~	Q	m ³ /h						
	kW	HP			30	50	100	150	200	219	234
Three-phase					500	833	1667	2500	3333	3650	3900
F 80/200B	30	40	IE3	H metres	56	56	54	49	41	34.5	
F 80/200A	37	50			62	62	61	57	50	45.5	40

Q = Flow rate H = Total manometric head HS = Suction height

Performance curves comply with EN ISO 9906 Grade 3B tolerance limits.

F 80/250

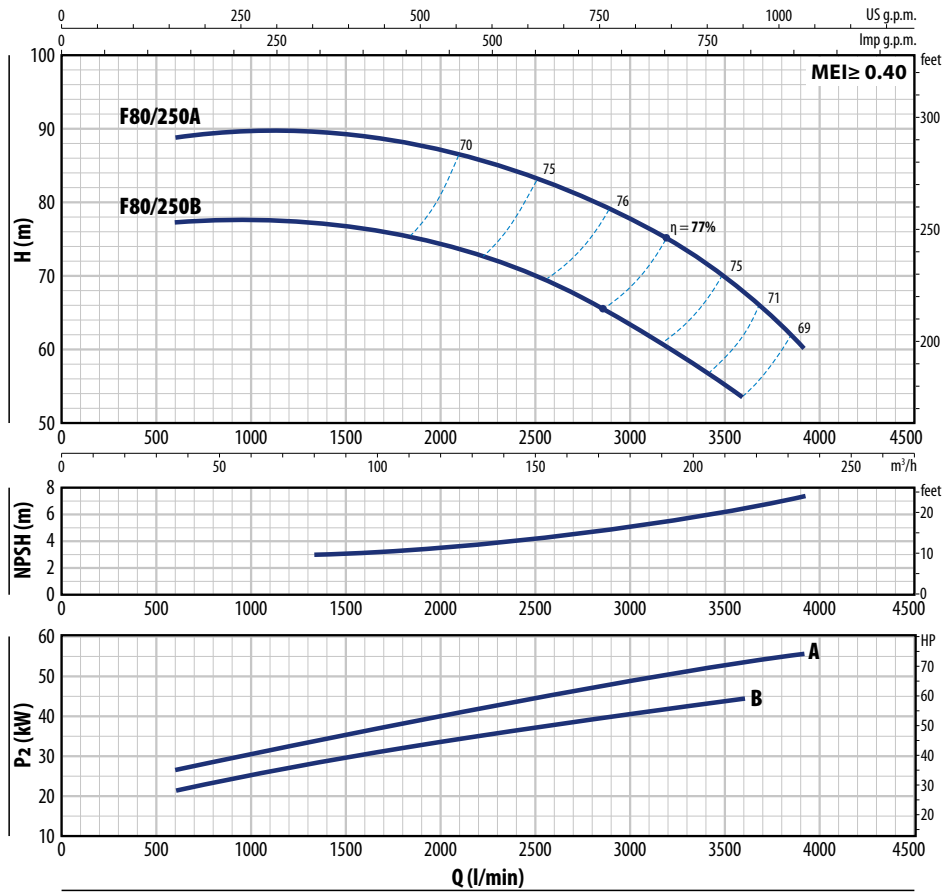

F 80/250

TYPE	POWER (P ₂)		3~	Q	Q						
	kW	HP			m ³ /h	36	50	100	150	200	216
Three-phase				l/min	600	833	1667	2500	3333	3600	3900
F 80/250B	45	60	IE3	H metres	77	77.5	76	70.5	58.5	54	
F 80/250A	55	75		88.5	89.5	89	83	72	68	60	

Q = Flow rate H = Total manometric head HS = Suction height

Performance curves comply with EN ISO 9906 Grade 3B tolerance limits.

F 100

CURVES AND PERFORMANCE DATA – HS=0 m

50 Hz

F 100/160

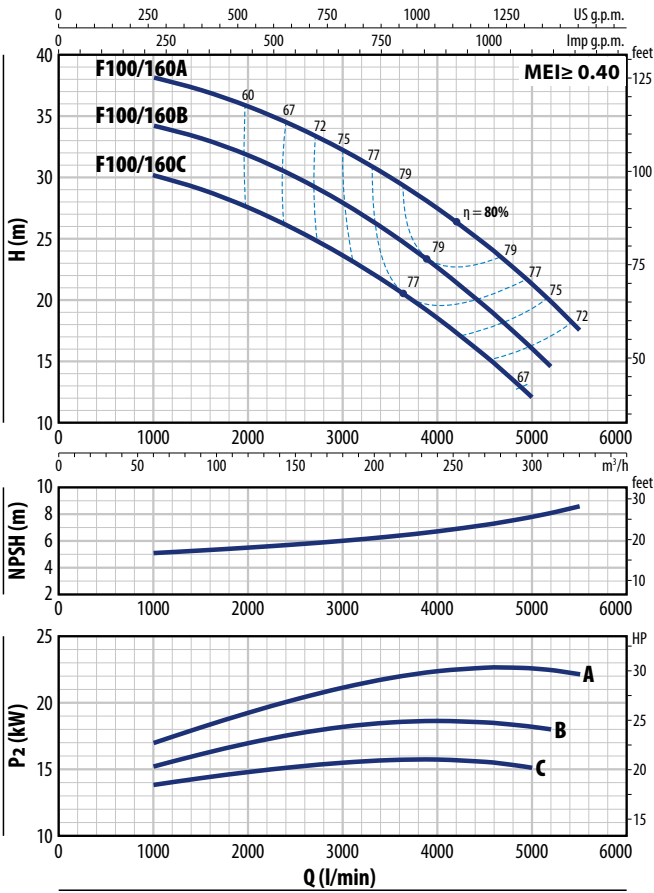

F 100/200

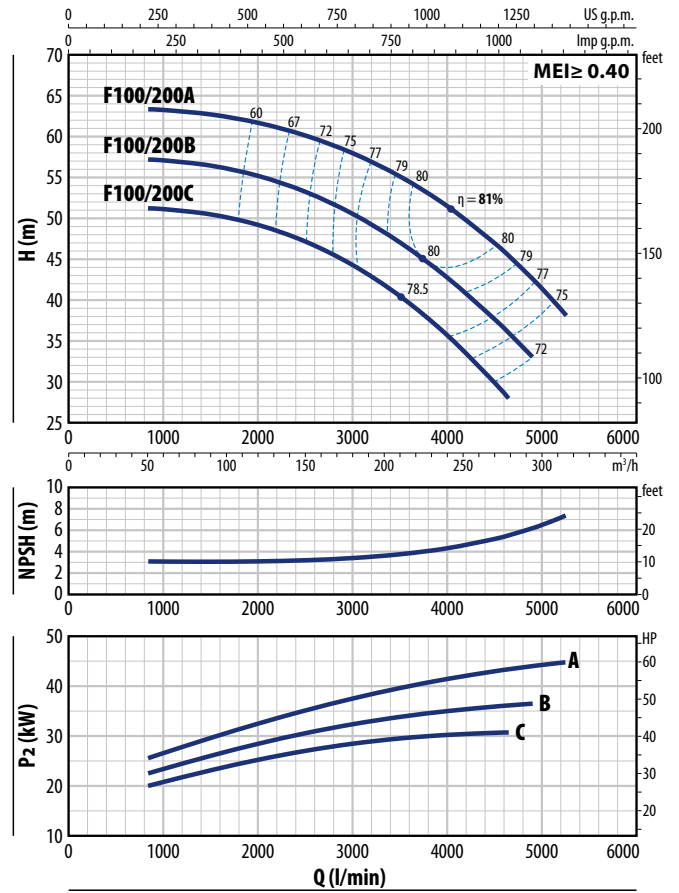

F 100/160

TYPE	POWER (P ₂)		3~	Q	m ³ /h														
	kW	HP			0	50	96	150	180	210	240	270	300	312	330				
Three-phase	kW	HP		l/min	1000	1500	2000	2500	3000	3500	4000	4500	5000	5200	5500				
F 100/160C	15	20	IE3	H metres	30	29	27.5	25.5	23.5	21	18.5	15.5	12						
F 100/160B	18.5	25			34	33	31.5	30	28	25.5	22.5	19.5	16	14.5					
F 100/160A	22	30			38	37	36	34	32	30	27.5	24.5	21	20	17.5				

F 100/200

TYPE	POWER (P ₂)		3~	Q	m ³ /h														
	kW	HP			0	50	96	150	180	210	240	279	294	300	315				
Three-phase	kW	HP		l/min	0	833	1600	2500	3000	3500	4000	4650	4900	5000	5250				
F 100/200C	30	40	IE3	H metres	51	51	50	47	44	40.5	35.5	28							
F 100/200B	37	50			57	57	56	53	50.5	47	42.5	36	33						
F 100/200A	45	60			63	63	62.5	60	58	55	51.5	45	42.5	41.5	38				

Q = Flow rate H = Total manometric head HS = Suction height

Performance curves comply with EN ISO 9906 Grade 3B tolerance limits.

F 100/250

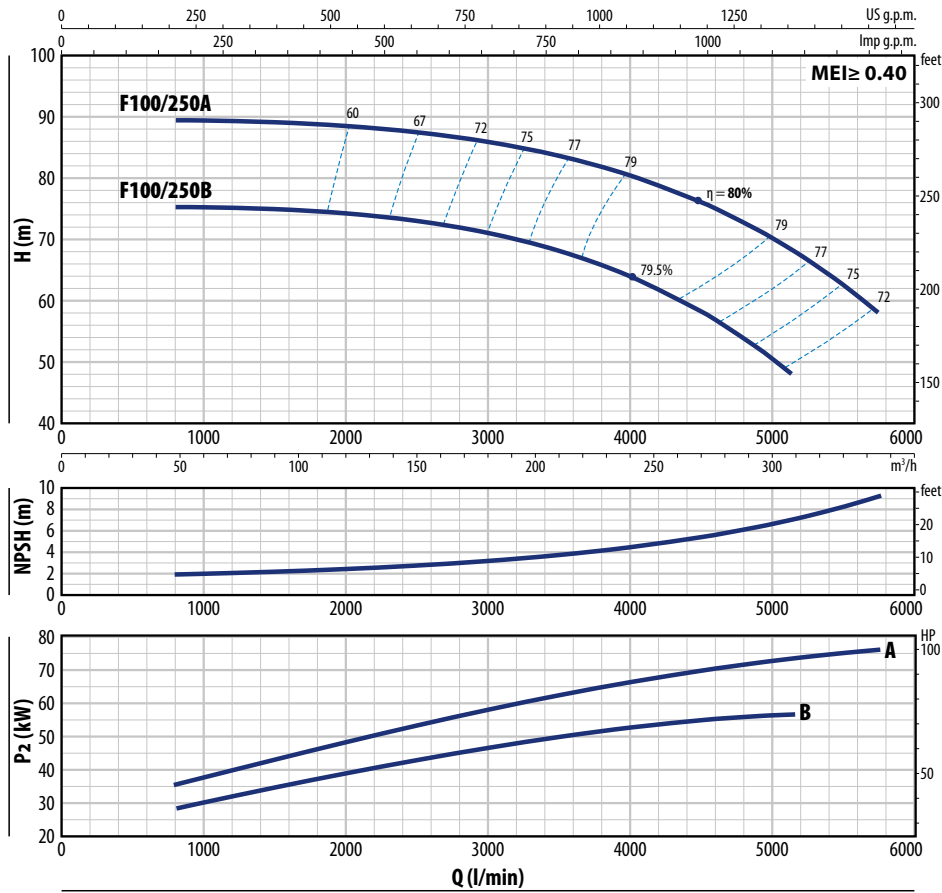

F 100/250

TYPE	POWER (P ₂)		3~	Q	48	96	150	180	210	240	300	309	345
	kW	HP			l/min	800	1600	2500	3000	3500	4000	5000	5150
F 100/250B	55	75	IE3	H metres	75	75	73	71	68	64	50.5	48	
F 100/250A	75	100			89	89	87.5	86	83.5	80.5	70	68	58

Q = Flow rate H = Total manometric head HS = Suction height

Performance curves comply with EN ISO 9906 Grade 3B tolerance limits.

ABSORPTION

TYPE	VOLTAGE
Single-ph.	230 V
Fm 32/160C	11.0 A
Fm 32/160B	12.0 A
Fm 40/125C	8.0 A
Fm 40/125B	10.0 A
Fm 40/160C	15.0 A
Fm 50/125C	13.5 A

TYPE	VOLTAGE			
	230 V - Δ	400 V - 人	400 V - Δ	690 V - 人
Three-phase				
F 32/160C	7.4 A	4.3 A	-	-
F 32/160B	8.6 A	5.0 A	-	-
F 32/160A	12.1 A	7.3 A	-	-
F 32/200C	17.8 A	10.3 A	-	-
F 32/200B	-	-	11.7 A	6.8 A
F 32/200A	-	-	14.9 A	8.6 A
F 32/200BH	12.6 A	7.3 A	-	-
F 32/200AH	15.4 A	8.9 A	-	-
F 32/250C	-	-	18.5 A	10.7 A
F 32/250B	-	-	22.0 A	12.7 A
F 32/250A	-	-	25.0 A	14.5 A
F 40/125C	5.2 A	3.0 A	-	-
F 40/125B	7.7 A	4.5 A	-	-
F 40/125A	9.0 A	5.2 A	-	-
F 40/160C	9.9 A	5.7 A	-	-
F 40/160B	12.6 A	7.3 A	-	-
F 40/160A	17.1 A	9.9 A	-	-
F 40/200B	-	-	12.6 A	7.3 A
F 40/200A	-	-	15.6 A	9.0 A
F 40/250C	-	-	21.0 A	12.1 A
F 40/250B	-	-	23.5 A	13.6 A
F 40/250A	-	-	30.5 A	17.6 A
F 50/125C	9.3 A	5.4 A	-	-
F 50/125B	13.1 A	7.6 A	-	-
F 50/125A	16.3 A	9.4 A	-	-
F 50/160C	15.7 A	9.1 A	-	-
F 50/160B	-	-	12.3 A	7.1 A
F 50/160A	-	-	15.5 A	9.0 A
F 50/200C	-	-	23.0 A	13.3 A
F 50/200B	-	-	29.5 A	17.1 A
F 50/200A	-	-	34.5 A	19.9 A
F 50/200AR	-	-	41.5 A	24.0 A

TYPE	VOLTAGE			
	230 V - Δ	400 V - 人	400 V - Δ	690 V - 人
Three-phase				
F 50/250D	-	19.0 A	19.0 A	11.0 A
F 50/250C	-	21.0 A	21.0 A	12.1 A
F 50/250B	-	27.0 A	27.0 A	15.6 A
F 50/250A	-	34.0 A	34.0 A	19.7 A
F 50/250AR	-	41.0 A	41.0 A	23.7 A
F 65/125C	17.3 A	10.0 A	-	-
F 65/125B	-	12.0 A	12.0 A	6.9 A
F 65/125A	-	16.5 A	16.5 A	9.5 A
F 65/160C	-	19.0 A	19.0 A	11.0 A
F 65/160B	-	23.0 A	23.0 A	13.3 A
F 65/160A	-	27.5 A	27.5 A	15.9 A
F 65/200B	-	30.0 A	30.0 A	17.3 A
F 65/200A	-	34.0 A	34.0 A	19.7 A
F 65/200AR	-	41.0 A	41.0 A	23.7 A
F 65/250C	-	53.0 A	53.0 A	30.6 A
F 65/250B	-	65.0 A	65.0 A	37.6 A
F 65/250A	-	79.0 A	79.0 A	45.7 A
F 80/160D	-	22.0 A	22.0 A	12.7 A
F 80/160C	-	29.0 A	29.0 A	16.8 A
F 80/160B	-	34.5 A	34.5 A	19.9 A
F 80/160A	-	39.0 A	39.0 A	22.5 A
F 80/200B	-	53.0 A	53.0 A	30.6 A
F 80/200A	-	65.0 A	65.0 A	37.6 A
F 80/250B	-	79.0 A	79.0 A	45.7 A
F 80/250A	-	98.0 A	98.0 A	56.6 A
F 100/160C	-	27.5 A	27.5 A	15.9 A
F 100/160B	-	32.5 A	32.5 A	18.8 A
F 100/160A	-	39.8 A	39.8 A	23.0 A
F 100/200C	-	53.0 A	53.0 A	30.6 A
F 100/200B	-	65.0 A	65.0 A	37.6 A
F 100/200A	-	79.0 A	79.0 A	45.7 A
F 100/250B	-	98.0 A	98.0 A	56.6 A
F 100/250A	-	126.0 A	126.0 A	72.8 A

MATERIALS AND COMPONENTS

1 Pump body	Cast iron, fitted with inlet and outlet flanged ports			
2 Cover/Motor bracket	Cast iron			
3 Impeller	Brass	for F32/160 - F32/200 - F40/125 - F40/160 - F40/200 - F50/125 - F50/160		
	Cast iron	for F32/250 - F40/250 - F50/200 - F50/250 - F65/125 - F65/160 - F65/200 - F65/250 F80/160 - F80/200 - F80/250 - F100/160 - F100/200 - F100/250		
4 Mechanical seal	Water pump	Seal	Shaft	Materials
	F32/160 - F40/125 - F40/160 - F50/125	FN-20	Ø 20 mm	Graphite Ceramic NBR
	F32/200 - F40/200 - F50/160 - F65/125	FN-24	Ø 24 mm	
	F50/200 - F65/160 - F65/200 - F80/160 - F100/160	FN-32 NU	Ø 32 mm	
	F32/250 - F40/250 - F50/250	FN-38	Ø 38 mm	
	F65/250 - F80/200 - F80/250B - F100/200	FN-40 NU	Ø 40 mm	
	F80/250A - F100/250	FH-45 NU	Ø 45 mm	
5 Motor shaft	Stainless steel AISI 431			
6 Electric motor	<p>Fm: single-phase 230 V - 50 Hz with winding integrated thermal motor protection (up to 1.5 kW)</p> <p>F: three-phase 230/400 V 50 Hz up to 4 kW - 400/690 V 50 Hz from 5.5 to 75 kW</p> <p>※ Pumps are equipped with high-efficiency motors (IEC 60034-30-1)</p> <p>class IE2 for single-phase models</p> <p>class IE3 for three-phase models</p> <p>Continuous running duty S1</p>			

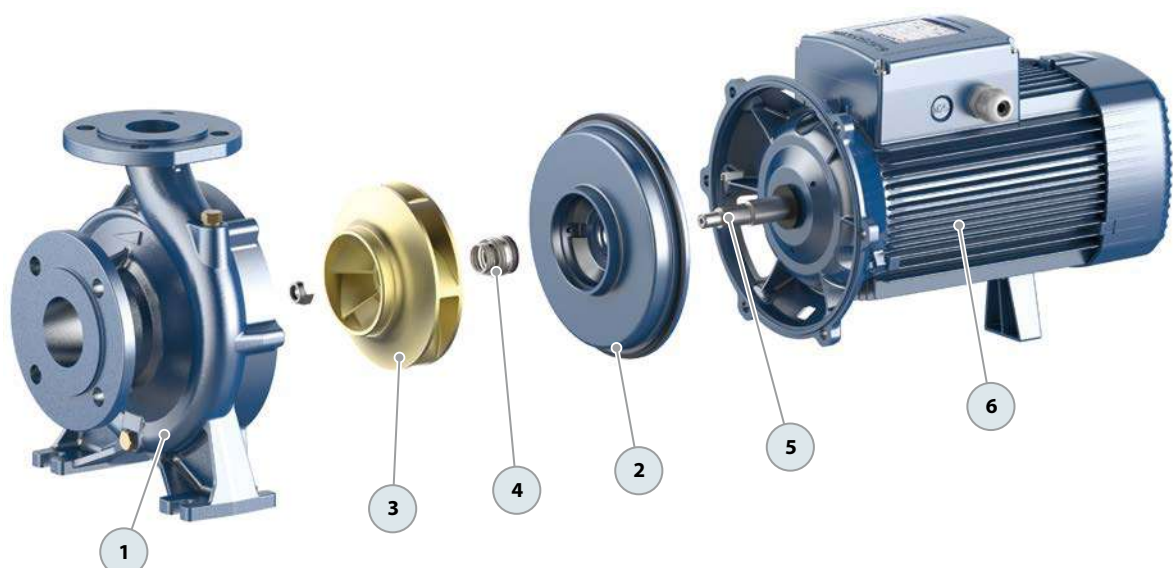

DIMENSIONS AND WEIGHT

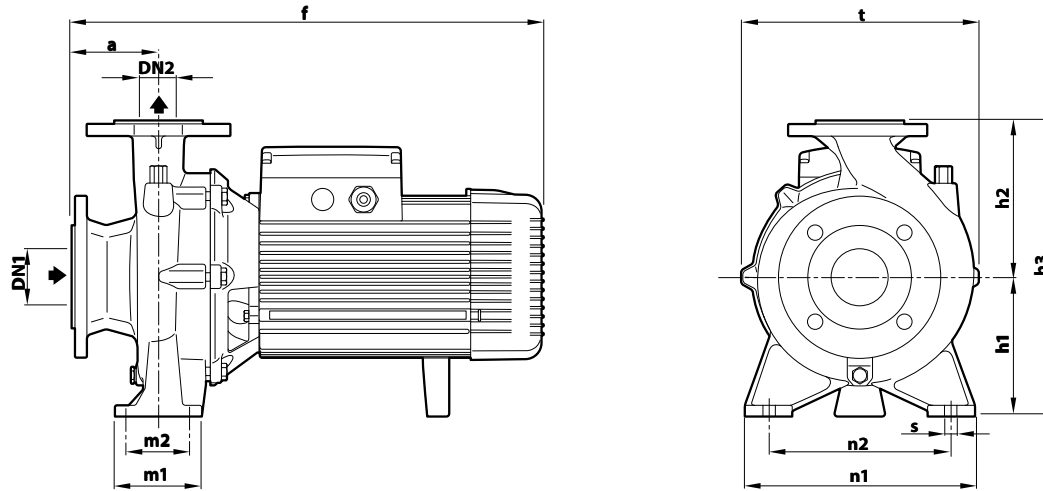

TYPE		PORTS		DIMENSIONS mm											kg											
Single-ph.	Three-ph.	DN1	DN2	a	f	h1	h2	h3	t	n1	n2	m1	m2	s	1~	3~										
Fm 32/160C	F 32/160C	50	32	80	416	132	160	292	240	245	190	100	70	14	32.6	32.5										
Fm 32/160B	F 32/160B				436										35.3	36.0										
-	F 32/160A				473										-	39.0										
-	F 32/200C				478										-	46.0										
-	F 32/200B				528										-	50.0										
-	F 32/200A				478										-	57.0										
-	F 32/200BH				-										-	41.7										
-	F 32/200AH			100	659	180	225	405	325	320	250	125	95		-	45.0										
-	F 32/250C			-	-	-	-	-	-	-	-	-	-		-	-	105.0									
-	F 32/250B			-	-	-	-	-	-	-	-	-	-		-	-	103.3									
-	F 32/250A			-	-	-	-	-	-	-	-	-	-		-	-	121.0									
Fm 40/125C	F 40/125C			65	40	80	421	112	140	252	244	210	160		100	70	31.5	31.0								
Fm 40/125B	F 40/125B						441										33.0	32.4								
-	F 40/125A						435										-	35.3								
Fm 40/160C	F 40/160C	473	-				36.0																			
-	F 40/160B	498	-				36.1																			
-	F 40/160A	548	-				43.0																			
-	F 40/200B	548	-				52.4																			
-	F 40/200A	498	160			180	340	277	265	212	-	-	-	-	59.0											
-	F 40/250C	659	180			225	405	329	320	250	125	95	-	-	105.0											
-	F 40/250B	-	-			-	-	-	-	-	-	-	-	-	105.0											
-	F 40/250A	-	-			-	-	-	-	-	-	-	-	-	128.5											
Fm 50/125C	F 50/125C	65	50			100	455	132	160	292	242	240	190	100	70	34.4	35.1									
-	F 50/125B						493									-	35.2									
-	F 50/125A						498									-	42.0									
-	F 50/160C			548	-		45.5																			
-	F 50/160B			669	160		180									340	273	265	212	100	70	-	-	51.0		
-	F 50/160A			769	-		-									-	-	-	-	-	-	-	-	57.0		
-	F 50/200C			768.5	-		-									-	-	-	-	-	-	-	-	100.0		
-	F 50/200B			669	160	200	360	316.5	-	-	-	-	-	-	114.0											
-	F 50/200A			769	-	-	-	-	-	-	-	-	-	-	127.0											
-	F 50/200AR			768.5	-	-	-	-	-	-	-	-	-	-	143.0											
-	F 50/250D			-	-	-	-	-	-	-	-	-	-	-	105.0											
-	F 50/250C			659	180	225	405	333	320	250	-	-	-	-	108.0											
-	F 50/250B			-	-	-	-	-	-	-	-	-	-	-	121.0											
-	F 50/250A			759	-	-	-	-	-	-	-	-	-	-	134.0											
-	F 50/250AR	-	-	-	-	-	-	-	-	-	-	-	149.0													
-	F 65/125C	80	65	125	520	160	180	340	292	280	212	125	95	-	53.4											
-	F 65/125B				570									-	58.0											
-	F 65/125A				674									-	64.0											
-	F 65/160C				674									200	360	295	-	-	-	-	-	-	-	100.0		
-	F 65/160B				676									-	-	-	-	-	-	-	-	-	-	100.0		
-	F 65/160A				676									-	-	-	-	-	-	-	-	-	-	112.0		
-	F 65/200B				776									-	-	-	-	-	-	-	-	-	-	119.3		
-	F 65/200A			-	-	-	-	-	336	-	-	-	-	-	132.0											
-	F 65/200AR			-	-	-	-	-	-	-	-	-	-	-	147.0											
-	F 80/160D			100	80	125	705	180	225	405	320	250	320	250	160	120	18	-	104.0							
-	F 80/160C						805											-	121.0							
-	F 80/160B						718											-	133.0							
-	F 80/160A						818											-	145.0							
-	F 100/160C						818											200	280	480	382	360	280	160	120	18
-	F 100/160B	818	-				-											-	-	-	-	-	-	-	-	155.0
-	F 100/160A	-	-	-	-	-	-	-	-	-	-	-	165.0													

DIMENSIONS AND WEIGHT

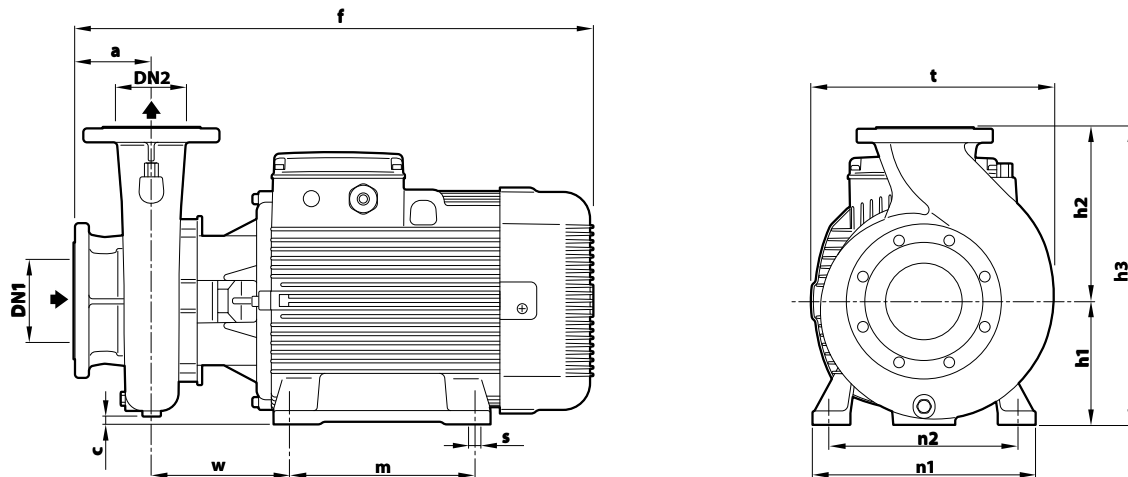

TYPE	PORTS		DIMENSIONS mm											kg 3~	
	DN1	DN2	a	f	h1	h2	h3	c	t	n1	n2	w	m		s
Three-ph.															
F 65/250C	80	65	100	809	200	250	450	15	377	360	318	214.5	305	19	211.0
F 65/250B															225.0
F 65/250A															239.0
F 80/200B	100	80	125	837	200	250	450	25	372	360	318	217.5	305	19	203.0
F 80/200A															218.0
F 80/250B															249.0
F 80/250A															547.0
F 100/200C	125	100	125	839	200	280	480	-	395	360	318	219.5	305	19	217.0
F 100/200B															231.0
F 100/200A															245.0
F 100/250B															551.2
F 100/250A															544.3

PORT FLANGES

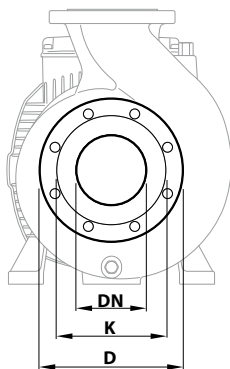

COUNTER-FLANGE

(CAN BE ORDERED SEPARATELY)

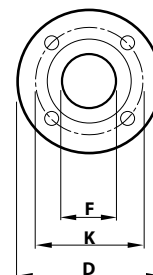

DN FLANGE mm	D mm	K mm	HOLES	
			N°	Ø (mm)
32	140	100	4	18
40	150	110		
50	165	125		
65	185	145		
80	200	160		
100	220	180	8	
125	250	210		

DN FLANGE mm	F COUNTER-FLANGE	D mm	K mm	HOLES	
				N°	Ø (mm)
32	1¼"	140	100	4	18
40	1½"	150	110		
50	2"	165	125		
65	2½"	185	145		
80	3"	200	160		
100	4"	220	180	8	
125	5"	250	210		

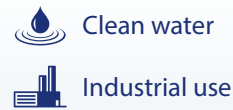

※ Pump entirely made of AISI 316 stainless steel

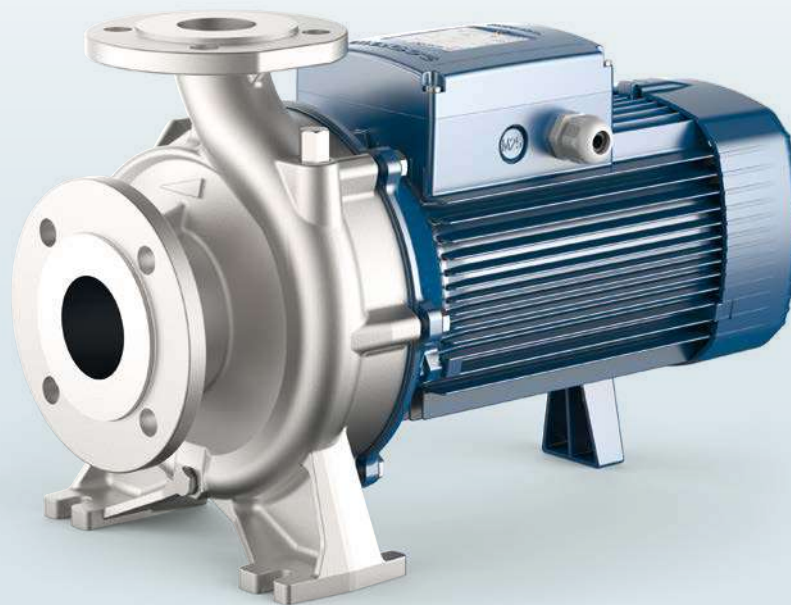

PERFORMANCE RANGE

- Flow rate up to **2200 l/min** (132 m³/h)
- Head up to **37 m**
- Power from **4 to 7.5 kW**

INSTALLATION AND USE

Designed to transfer clean water free from abrasive particles and liquids that will not damage the pump's components.

- Water supply
- Pressurization
- Irrigation
- Water circulation in air conditioning systems
- Power washing systems
- Firefighting systems
- Industrial applications
- Agriculture applications

ELECTRIC MOTOR

The three-phase pumps are equipped with newly developed electric motors designed to work with inverters, which guarantee stable and quiet operation.

Efficiency class **IE3** for three-phase motors, **IE2** for single-phase motors, class F insulation and IP55 protection.

APPLICATION LIMITS

- Manometric suction head up to **7 m**
- Liquid temperature between **-10 °C** and **+90 °C**
- Ambient temperature between **-10 °C** and **+40 °C**
- Maximum pressure in the pump body **10 bar** (PN10)

AVAILABLE UPON REQUEST

- ※ Mechanical seal options available
- ※ Different voltage requirements 60 Hz frequency
- ※ Handling of liquids with higher or lower temperatures
- ※ Adaptability to operate in high or low temperature environments

PERFORMANCE DATA

MEI ≥ 0.40 **50 Hz**

TYPE	POWER (P ₂)			PERFORMANCE					
	kW	HP	3~	Q l/min	H m	Q l/min	H m	Q l/min	H m
F 50/160C-I	4	5.5	IE3	300	27	800	20	1000	16
F 50/160B-I	5.5	7.5		300	32	900	26	1100	21
F 50/160A-I	7.5	10		300	37	900	32	1100	27
F 65/125C-I	4	5.5	IE3	600	16	1600	12.5	1800	11
F 65/125B-I	5.5	7.5		600	18	1800	14.5	1000	13
F 65/125A-I	7.5	10		600	23	1800	21	1100	18

Q = Flow rate H = Total manometric head HS = Suction height

Performance curves comply with EN ISO 9906 Grade 3B tolerance limits.

MATERIALS AND COMPONENTS

1	Pump body	Stainless steel AISI 316		
2	Cover	Stainless steel AISI 316		
3	Impeller	Stainless steel AISI 316		
4	Mechanical seal	Type FN-24SV	Shaft Ø 24 mm	Materials Silicon carbide / Silicon carbide / Viton
5	Motor shaft	Stainless steel AISI 316L		

6 Electric motor

Three-phase 230/400 V - 50 Hz for 4 kW 400/690 V - 50 Hz 5.5 to 7.5 kW

※ The pumps are equipped with high-efficiency motors (IEC 60034-30-1) in class **IE3**

Continuous running duty **S1**

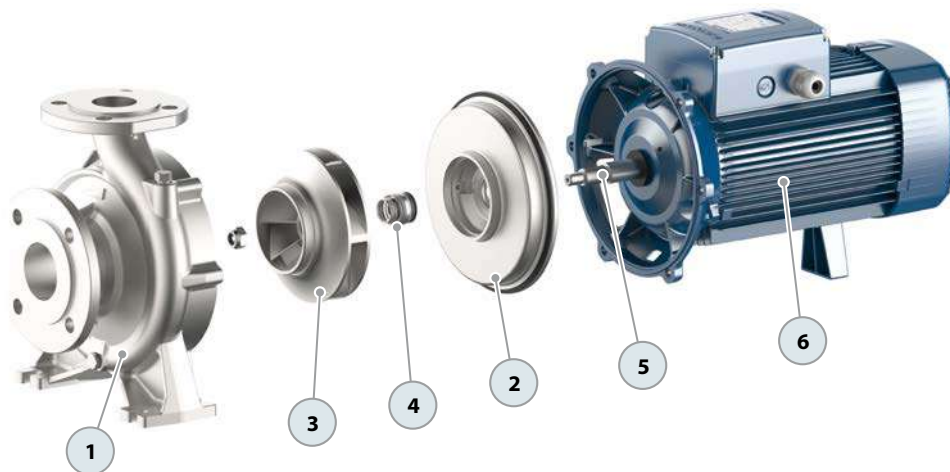

DIMENSIONS AND WEIGHT

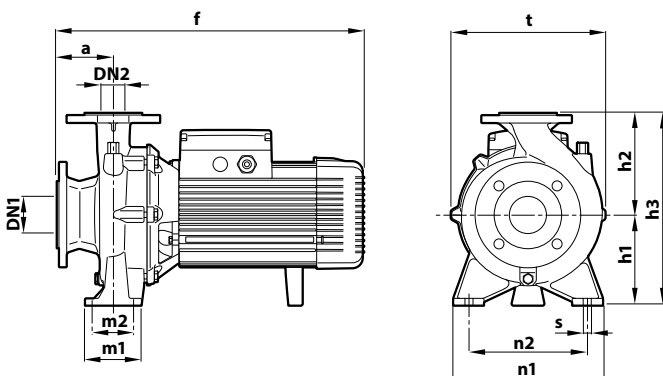

ABSORPTION

TYPE	VOLTAGE			
	Three-phase 230 V - Δ	400 V - Δ	400 V - Δ	690 V - Δ
F 50/160C-I	15.7 A	9.1 A	-	-
F 50/160B-I	-	-	12.3 A	7.1 A
F 50/160A-I	-	-	15.5 A	9.0 A
F 65/125C-I	17.3 A	10.0 A	-	-
F 65/125B-I	-	-	12.0 A	6.9 A
F 65/125A-I	-	-	16.5 A	9.5 A

TYPE	PORTS		DIMENSIONS mm											kg 3~
	DN1	DN2	a	f	h1	h2	h3	t	n1	n2	m1	m2	s	
Three-phase														
F 50/160C-I	65	50	100	498	160	180	340	269	265	212	100	70	14	49.0
F 50/160B-I				548										55.0
F 50/160A-I				520										62.0
F 65/125C-I	570	58.2												
F 65/125B-I	80	65		520										58.2
F 65/125A-I			570	68.0										



Clean water



Industrial use



PERFORMANCE RANGE

- Flow rate up to **2900 l/min** (174 m³/h)
- Head up to **23.8 m**
- Power from **0.37 to 9.2 kW**

INSTALLATION AND USE

- Designed to transfer clean water free from abrasive particles and liquids that will not damage the pump's components.
- Water supply
- Pressurization
- Irrigation
- Water circulation in air conditioning systems
- Power washing systems
- Firefighting systems
- Industrial applications
- Agriculture applications

Installation is to be carried out in well-ventilated enclosed locations or otherwise protected from the weather.

ELECTRIC MOTOR

The three-phase pumps are equipped with newly developed electric motors designed to work with inverters, which guarantee stable and quiet operation.

Efficiency class **IE3** for three-phase motors, **IE2** for single-phase motors, class F insulation and IP55 protection.

APPLICATION LIMITS

- Manometric suction head up to **7 m**
- Liquid temperature between **-10 °C** and **+90 °C**
- Ambient temperature between **-10 °C** and **+40 °C**
- Maximum pressure in the pump body **10 bar (PN10)**

AVAILABLE UPON REQUEST

- ✘ Different voltage requirements 60 Hz frequency
- ✘ Handling of liquids with higher or lower temperatures
- ✘ Adaptability to operate in high or low temperature environments
- ✘ Counterflange KIT including screws, nuts and gaskets



PERFORMANCE RANGE – n= 1450 min⁻¹

50 Hz

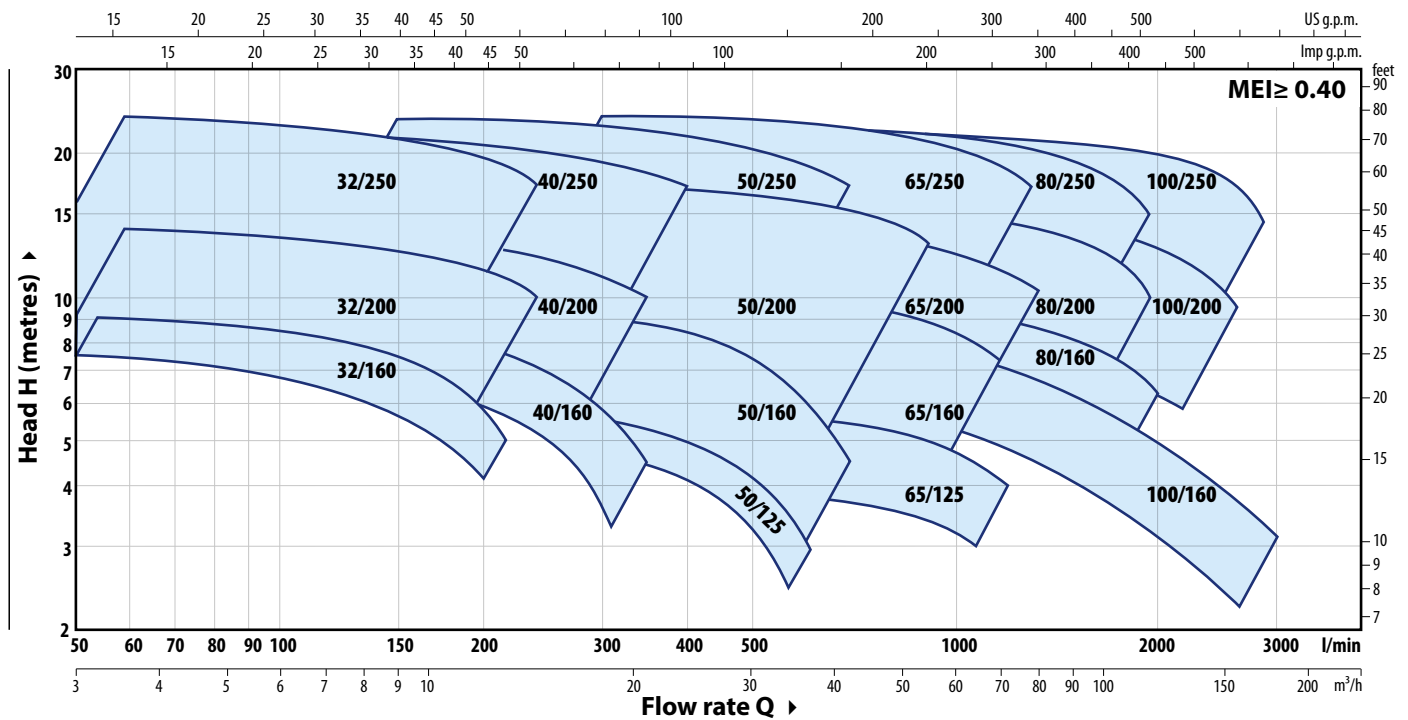

PERFORMANCE DATA – n= 1450 min⁻¹

50 Hz

TYPE	POWER (P ₂)		PERFORMANCE							
	kW	HP	Q	H	Q	H	Q	H	Q	H
Three-ph.			l/min	m	l/min	m	l/min	m	l/min	m
F4-32/160B	0.37	0.5	50	7.5	165	5.6	200	4.5		
F4-32/160A	0.37	0.5	50	9	175	6.8	225	5		
F4-32/200B	0.75	1	50	12.5	230	9.5	250	9		
F4-32/200A	1.1	1.5	50	14	240	10.8	250	10.5		
F4-32/200BH	0.75	1	50	11.3	140	9.6	150	9.2		
F4-32/200AH	0.75	1	50	13.8	150	11.5	160	11		
F4-32/250C	1.1	1.5	50	18.4	220	15	220	15		
F4-32/250B	1.5	2	50	21.7	250	17.4	250	17.4		
F4-32/250A	2.2	3	50	23.8	270	18.7	270	18.7		
F4-40/160B	0.37	0.5	50	7.5	220	6.0	320	3.5		
F4-40/160A	0.55	0.75	50	9	245	7.1	350	4.5		
F4-40/200B	0.75	1	50	11.5	280	8.9	350	7		
F4-40/200A	1.1	1.5	50	13.8	310	10.9	350	10		
F4-40/250C	1.1	1.5	50	15.5	320	12.4	400	10		
F4-40/250B	1.5	2	50	17.5	330	14.2	400	12		
F4-40/250A	2.2	3	50	22	380	17.5	400	17		
F4-50/125B	0.55	0.75	150	5	420	4.0	600	2		
F4-50/125A	0.55	0.75	150	6	450	4.8	600	3		
F4-50/160B	0.75	1	150	8	440	6.5	650	3.8		
F4-50/160A	1.1	1.5	150	9.3	460	7.8	700	4.5		
F4-50/200C	1.5	2	200	11	660	9.3	850	7.5		
F4-50/200B	2.2	3	200	13	720	10.9	850	9.5		
F4-50/200A	2.2	3	200	15	770	12.8	900	11.2		
F4-50/200AR	3	4	200	17	800	14.5	900	13.2		
F4-50/250D	1.1	1.5	150	12.5	425	10.1	650	5		
F4-50/250C	1.5	2	150	14	450	11.2	700	5		
F4-50/250B	2.2	3	150	18	510	14.6	700	10.5		
F4-50/250A	2.2	3	150	20	550	16.3	700	13		
F4-50/250AR	3	4	150	23.5	570	19.9	700	17		

TYPE	POWER (P ₂)		PERFORMANCE							
	kW	HP	Q	H	Q	H	Q	H	Q	H
Three-ph.			l/min	m	l/min	m	l/min	m	l/min	m
F4-65/125B	0.75	1	300	4.7	900	3.8	1100	3		
F4-65/125A	1.1	1.5	300	5.7	1000	4.7	1200	4		
F4-65/160C	1.1	1.5	300	8	910	6.7	1100	5.5		
F4-65/160B	1.5	2	300	9.1	950	7.6	1200	5.7		
F4-65/160A	2.2	3	300	10.1	990	8.5	1200	7		
F4-65/200A	2.2	3	300	12	1100	9.6	1250	8.5		
F4-65/200AR	3	4	300	14	1140	11.2	1300	10		
F4-65/250B	4	5.5	200	21.8	980	18.8	1250	15.5		
F4-65/250A	5.5	7.5	200	23.5	1000	20.6	1300	17		
F4-80/160D	1.5	2	300	6.3	1400	4.8	2000	2.5		
F4-80/160C	2.2	3	300	7.5	1480	5.7	2000	3.8		
F4-80/160B	2.2	3	300	8.8	1580	6.8	2000	5		
F4-80/160A	3	4	300	10	1660	7.7	2000	6.2		
F4-80/200B	4	5.5	300	14	1540	10.9	1800	9		
F4-80/200A	5.5	7.5	300	15.5	1625	12.6	1900	10.5		
F4-80/250B	5.5	7.5	300	19.5	1500	16.1	1800	13.5		
F4-80/250A	7.5	10	300	22	1400	19.9	1950	15		
F4-100/160B	2.2	3	400	8.3	1950	5.7	2600	3.5		
F4-100/160A	3	4	400	10	2060	6.9	2800	4.7		
F4-100/200C	4	5.5	400	12.7	1850	9.6	2300	7		
F4-100/200B	5.5	7.5	400	14.2	1950	10.9	2400	8.5		
F4-100/200A	5.5	7.5	400	15.8	2050	12.6	2600	9.5		
F4-100/250B	7.5	10	400	18.5	1950	15.9	2600	11.5		
F4-100/250A	9.2	12.5	400	22	2100	19.3	2900	13.5		

Q = Flow Rate

H = Total manometric head

Performance curves comply with EN ISO 9906 Grade 3B tolerance limits.

DIMENSIONS AND WEIGHT

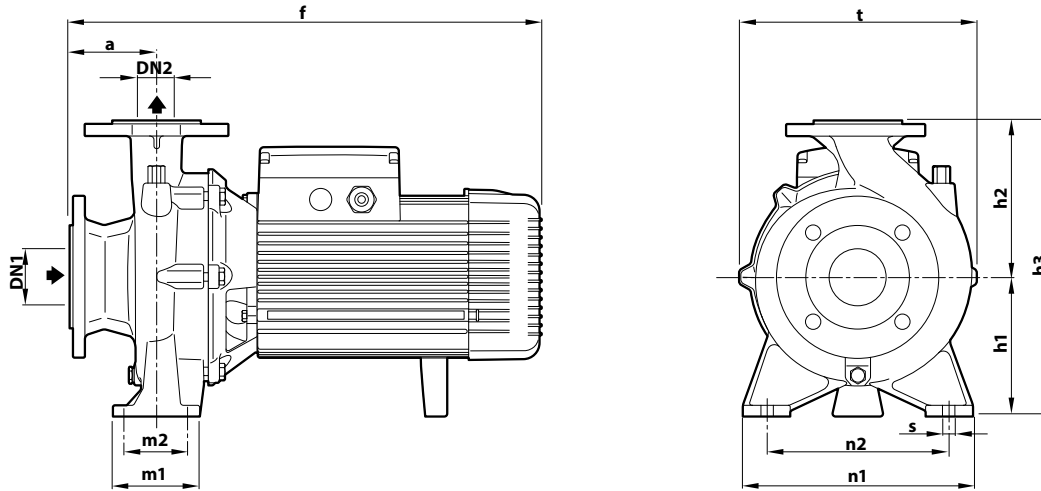

TYPE	PORTS		DIMENSIONS mm											kg							
	DN1	DN2	a	f	h3	h1	h2	t	n2	n1	m1	m2	s								
Three-phase																					
F4-32/160B	50	32	80	412	292	132	160	242	190	240	100	70	14	31.2							
F4-32/160A																				31.2	
F4-32/200B																					43.0
F4-32/200A							478	340						160	180	270			95		43.5
F4-32/200BH																					37.9
F4-32/200AH																42.4					
F4-32/250C					100	531	405	180	225	330	250	320		125	95		64.1				
F4-32/250B																	63.1				
F4-32/250A							581										68.7				
F4-40/160B			65	40	80	412	292	132	160	240	190	240		100	70	14	32.5				
F4-40/160A																		32.9			
F4-40/200B					100	498	340	160	180	275	212	265					46.0				
F4-40/200A																	46.2				
F4-40/250C							531	405	180	225	328	250	320	125	95			60.1			
F4-40/250B																		60.1			
F4-40/250A							581											72.4			
F4-50/125B	65	50	80	431	292	132	160	242	190	240	100	70	14	32.2							
F4-50/125A																			32.2		
F4-50/160B							498	340		180				269						44.4	
F4-50/160A					100	538		160			212	265					59.2				
F4-50/200C																	68.3				
F4-50/200B							589	360		200	316							68.5			
F4-50/200A																		68.8			
F4-50/200AR																		59.9			
F4-50/250D						531											63.3				
F4-50/250C																	68.7				
F4-50/250B							405	180	225	337	250	320		125	95		69.1				
F4-50/250A						581											78.0				
F4-65/125B			80	65	80	520	340		180	291	212	280		125	95	14	50.2				
F4-65/125A																					
F4-65/160C					100	542		160									55.0				
F4-65/160B								360		200	300						58.7				
F4-65/160A							592											65.0			
F4-65/200A																		72.0			
F4-65/200AR							595	405	180	225	340	250	320					78.4			
F4-65/250B																	111.2				
F4-65/250A						680	450	200	250	373	280	360	160	120	18		139.6				

DIMENSIONS AND WEIGHT

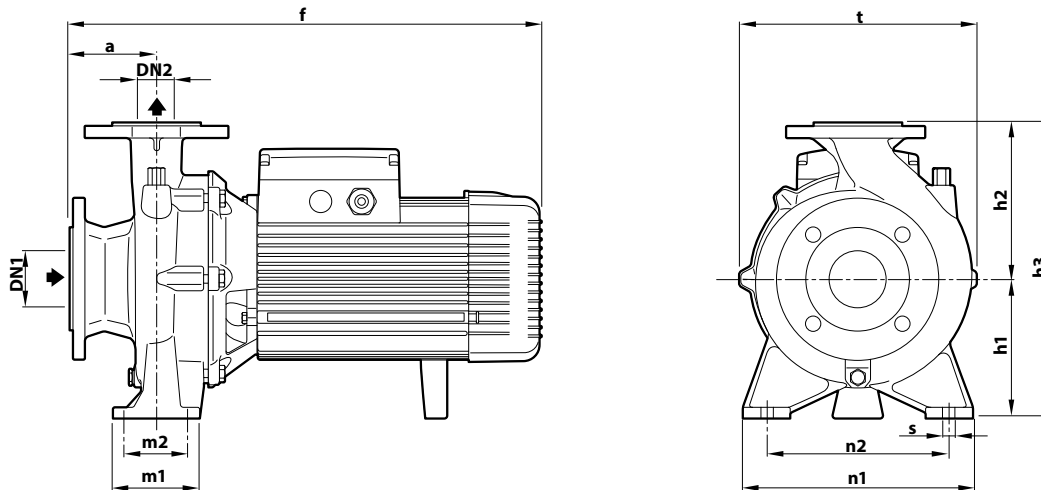

TYPE	PORTS		DIMENSIONS mm											kg
	DN1	DN2	a	f	h3	h1	h2	t	n2	n1	m1	m2	s	
Three-phase														
F4-80/160D	100	80	125	574	405	180	225	330	250	320	125	95	14	66.0
F4-80/160C				624										67.3
F4-80/160B				624	70.0									
F4-80/160A				624	76.4									
F4-80/200B				709	430	250	360	280	345	100.0				
F4-80/200A				709	430	250	360	280	345	130.2				
F4-80/250B				727	480	200	280	405	315	400	160	120	18	123.0
F4-80/250A				727	480	200	280	405	315	400	160	120	18	137.6
F4-100/160B	125	100	125	638	480	200	280	362	280	360	160	120	18	96.2
F4-100/160A				711										97.0
F4-100/200C				711	124.1									
F4-100/200B				711	116.0									
F4-100/200A				711	122.0									
F4-100/250B				140	747	505	225	422	315	400	156.0			

PORT FLANGES

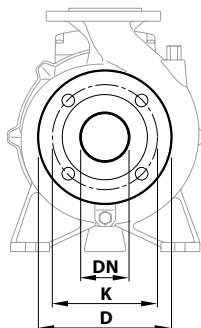

DN FLANGE mm	D mm	K mm	HOLES	
			N°	Ø (mm)
32	140	100	4	18
40	150	110		
50	165	125		
65	185	145		
80	200	160	8	18
100	220	180		
125	250	210		

COUNTER-FLANGE

(CAN BE ORDERED SEPARATELY)

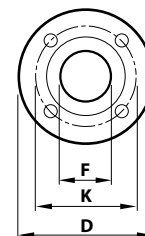

DN FLANGE mm	F COUNTER-FLANGE	D mm	K mm	HOLES	
				N°	Ø (mm)
32	1¼"	140	100	4	18
40	1½"	150	110		
50	2"	165	125		
65	2½"	185	145		
80	3"	200	160	8	18
100	4"	220	180		
125	5"	250	210		

ABSORPTION

TYPE	VOLTAGE	
	230 V - Δ	400 V - Y
Three-phase		
F4-32/160B	1.9 A	1.1 A
F4-32/160A	2.2 A	1.3 A
F4-32/200B	3.6 A	2.1 A
F4-32/200A	4.0 A	2.3 A
F4-32/200BH	3.3 A	1.9 A
F4-32/200AH	3.5 A	2.0 A
F4-32/250C	5.7 A	3.3 A
F4-32/250B	7.3 A	4.2 A
F4-32/250A	9.5 A	5.5 A
F4-40/160B	1.7 A	1.0 A
F4-40/160A	2.8 A	1.6 A
F4-40/200B	3.6 A	2.1 A
F4-40/200A	4.2 A	2.4 A
F4-40/250C	5.5 A	3.2 A
F4-40/250B	6.1 A	3.5 A
F4-40/250A	9.5 A	5.5 A
F4-50/125B	2.2 A	1.3 A
F4-50/125A	2.6 A	1.5 A
F4-50/160B	3.3 A	1.9 A
F4-50/160A	4.2 A	2.4 A
F4-50/200C	6.1 A	3.5 A
F4-50/200B	8.0 A	4.6 A
F4-50/200A	9.0 A	5.2 A
F4-50/200AR	10.6 A	6.1 A
F4-50/250D	4.8 A	2.8 A
F4-50/250C	5.9 A	3.4 A
F4-50/250B	9.9 A	5.7 A
F4-50/250A	11.1 A	6.4 A
F4-50/250AR	11.8 A	6.8 A
F4-65/125B	3.6 A	2.1 A
F4-65/125A	4.5 A	2.6 A
F4-65/160C	5.2 A	3.0 A
F4-65/160B	5.9 A	3.4 A
F4-65/160A	7.8 A	4.5 A

TYPE	VOLTAGE	
	230 V - Δ	400 V - Y
Three-phase		
F4-65/200A	9.0 A	5.2 A
F4-65/200AR	11.8 A	6.8 A
F4-65/250B	17.3 A	10.0 A
F4-65/250A	21.7 A	13.5 A
F4-80/160D	5.9 A	3.4 A
F4-80/160C	10.0 A	5.8 A
F4-80/160B	10.2 A	5.9 A
F4-80/160A	10.6 A	6.1 A
F4-80/200B	13.8 A	8.0 A
F4-80/200A	18.2 A	10.5 A
F4-80/250B	20.8 A	12.5 A
F4-80/250A	25.6 A	14.8 A
F4-100/160B	9.0 A	5.2 A
F4-100/160A	13.0 A	7.5 A
F4-100/200C	14.2 A	8.2 A
F4-100/200B	17.8 A	10.3 A
F4-100/200A	20.8 A	12.0 A
F4-100/250B	26.8 A	15.5 A
F4-100/250A	34.1 A	19.7 A

MATERIALS AND COMPONENTS

1 Pump body	Cast iron, fitted with inlet and outlet flanged ports			
2 Cover	Cast iron			
3 Impeller	Brass	for F4-32/160 - 32/200 - 40/160 - 40/200 - 50/125 - 50/160		
	Cast iron	for F4-32/250 - 40/250 - 50/200 - 50/250 - 65/125 - 65/160 - 65/200 - 65/250 F4-80/160 - 80/200 - 80/250 - 100/160 - 100/200 - 100/250		
4 Mechanical seal	Water pump	Seal	Shaft	Materials
	F4-32/160	FN-20	Ø 20 mm	Graphite / Ceramic / NBR
	F4-40/160			
	F4-50/125			
	F4-32/200	FN-24	Ø 24 mm	Graphite / Ceramic / NBR
	F4-40/200			
	F4-50/160			
	F4-65/125	FN-32 NU	Ø 32 mm	Graphite / Ceramic / NBR
	F4-50/200			
	F4-65/200			
	F4-80/160	FN-38	Ø 38 mm	Graphite / Ceramic / NBR
	F4-100/160			
	F4-32/250			
F4-40/250	FN-40 NU	Ø 40 mm	Graphite / Ceramic / NBR	
F4-50/250				
F4-65/250				
F4-80/200	FN-45 NU	Ø 45 mm	Graphite / Ceramic / NBR	
F4-100/200				
F4-80/250				
F4-100/250				
5 Motor shaft	Stainless steel AISI 431			
6 Electric motor	F4: 4-pole three-phase 230/400 V - 50 Hz			
	※ The pumps are equipped with high-efficiency motors (IEC 60034-30-1) class IE3 Continuous running duty S1			

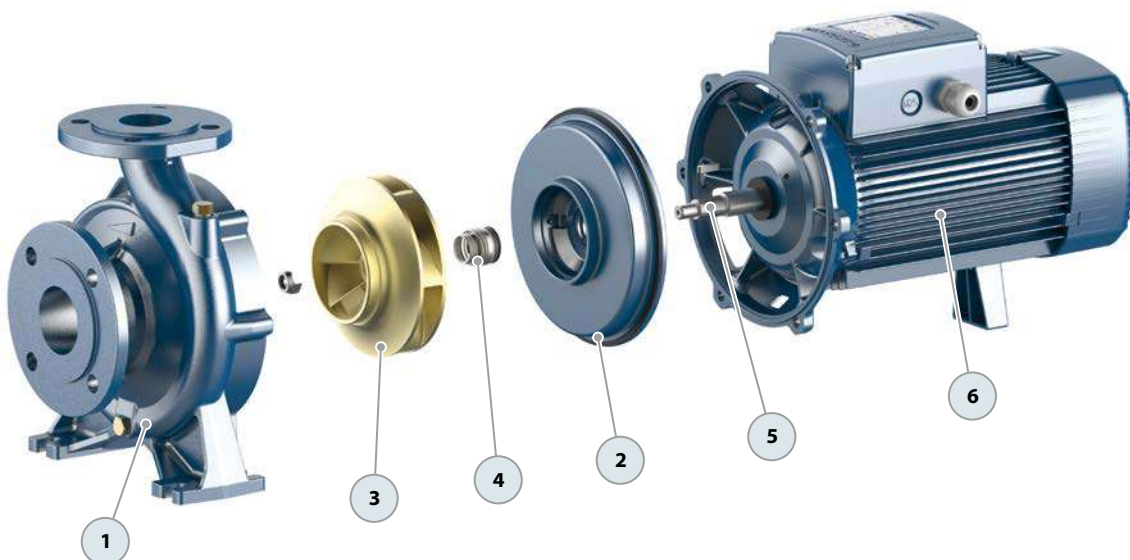

-  Clean water
-  Civil use
-  Industrial use
-  Agricultural use



PERFORMANCE RANGE

- Flow rate up to **5750 l/min** (345 m³/h)
- Head up to **98 m**

INSTALLATION AND USE

Standardized centrifugal pumps equipped with a support structure and built according to EN733 standard.

Designed to transfer clean water free from abrasive particles and liquids that will not damage the pump's components.

- **Water supply**
- **Pressurization**
- **Irrigation**
- **Firefighting systems**
- **Industrial applications**
- **Agriculture applications**
- **Civil, industrial, and agricultural applications**
- **Air conditioning, cooling, heating, and circulation systems**

APPLICATION LIMITS

- Manometric suction head up to **7 m**
- Liquid temperature between **-10 °C** and **+90 °C**
- Maximum pressure in the pump body **10 bar** (PN10)

AVAILABLE UPON REQUEST

- ✘ Mechanical seal options available
- ✘ Pumps for motors with 60 Hz frequency
- ✘ Handling of liquids with higher or lower temperatures
- ✘ Adaptability to operate in high or low temperature environments
- ✘ Counterflange KIT including screws, nuts and gaskets



PERFORMANCE RANGE - n= 2900 min⁻¹

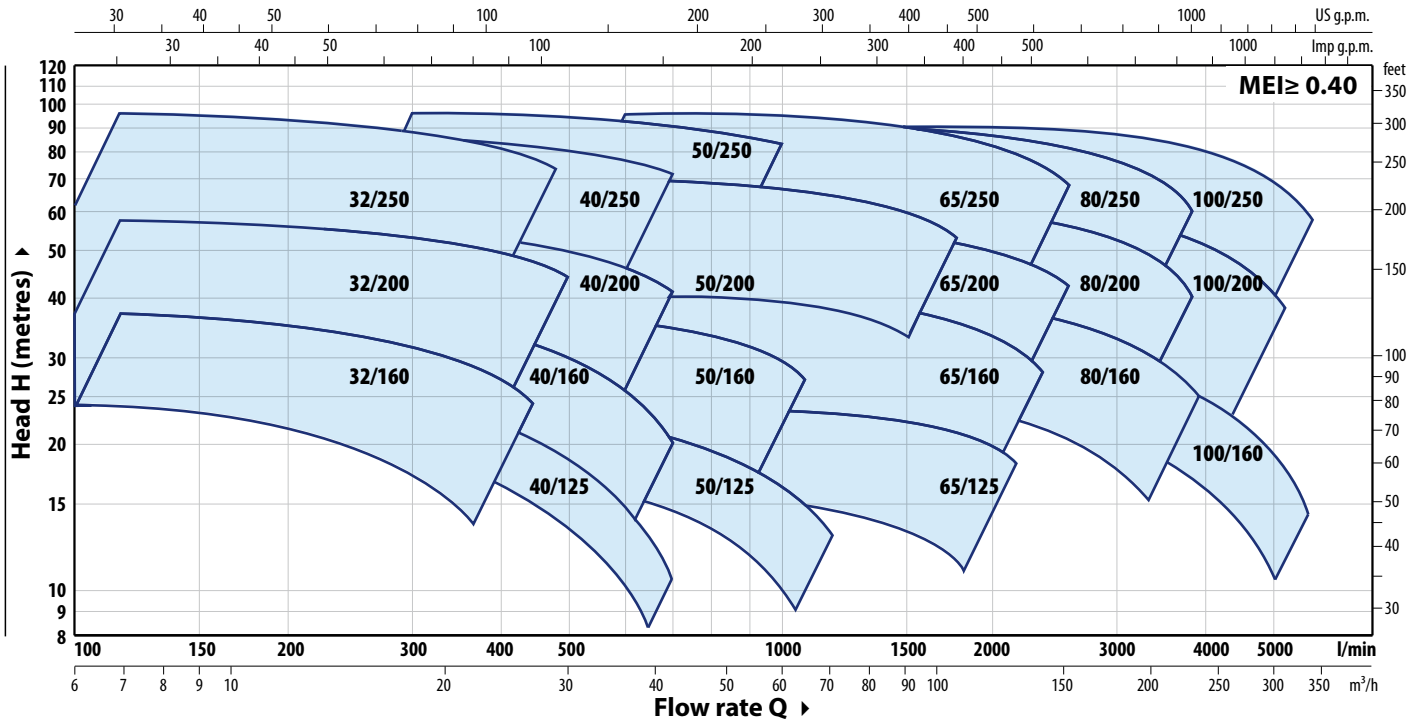

PERFORMANCE DATA - n= 2900 min⁻¹

TYPE	MOTOR TO BE COUPLED		PERFORMANCE n= 2900 min ⁻¹					
	kW	HP	Q m³/h	H m	Q m³/h	H m	Q m³/h	H m
FG2-32/160C	1.5	2	6	24	16	19.8	21	14
FG2-32/160B	2.2	3	6	30	18	23.6	24	17
FG2-32/160A	3	4	6	37	20.4	30.2	27	24
FG2-32/200C	4	5.5	6	44	27	31.5	27	31.5
FG2-32/200B	5.5	7.5	6	51	28	37.7	30	36
FG2-32/200A	7.5	10	6	57	29	45.3	30	44
FG2-32/200BH	3	4	6	45	17	38.4	18	37
FG2-32/200AH	4	5.5	6	55	18	46.1	19.2	44
FG2-32/250C	9.2	12.5	6	75	28	58.6	27	60
FG2-32/250B	11	15	6	87	32	67.6	30	70
FG2-32/250A	15	20	6	97	35	73.6	30	80
FG2-40/125C	1.1	1.5	6	16	23	12.0	33	6
FG2-40/125B	1.5	2	6	20.5	26	15.1	36	9
FG2-40/125A	2.2	3	6	26	29	19.3	42	10
FG2-40/160C	2.2	3	6	27	25	22.0	36	14
FG2-40/160B	3	4	6	32	27	25.9	36	20
FG2-40/160A	4	5.5	6	38	30	30.2	42	20
FG2-40/200B	5.5	7.5	6	47	33	36.3	42	28
FG2-40/200A	7.5	10	6	55	36	46.2	42	41
FG2-40/250C	9.2	12.5	6	64	39	49.9	42	47
FG2-40/250B	11	15	6	71	40	56.8	42	55
FG2-40/250A	15	20	6	88	42	72.0	42	72
FG2-50/125C	2.2	3	18	17.5	49	13.0	72	6
FG2-50/125B	3	4	18	20.7	51	15.6	72	9
FG2-50/125A	4	5.5	18	23.5	55	18.4	72	13
FG2-50/160C	4	5.5	18	27	48	20.7	60	16
FG2-50/160B	5.5	7.5	18	32	52	26.3	72	18
FG2-50/160A	7.5	10	18	37	54	32.1	81	20
FG2-50/200C	11	15	24	44	82	37.0	102	30
FG2-50/200B	15	20	24	52	86	43.7	102	38
FG2-50/200A	18.5	25	24	61	91	52.0	108	45
FG2-50/200AR	22	30	24	69	96	58.2	108	53
FG2-50/250D	9.2	12.5	18	51	53	37.6	54	37
FG2-50/250C	11	15	18	59	60	43.0	60	43
FG2-50/250B	15	20	18	72	60	59.0	60	59
FG2-50/250A	18.5	25	18	85	60	73.0	60	73
FG2-50/250AR	22	30	18	95	60	83.0	60	83

TYPE	MOTOR TO BE COUPLED		PERFORMANCE n= 2900 min ⁻¹					
	kW	HP	Q m³/h	H m	Q m³/h	H m	Q m³/h	H m
FG2-65/125C	4	5.5	36	16	96	12.6	108	11
FG2-65/125B	5.5	7.5	36	18	101	15.4	120	13
FG2-65/125A	7.5	10	36	23	108	20.9	132	18
FG2-65/160C	9.2	12.5	36	32	108	27.0	132	22
FG2-65/160B	11	15	36	36.5	113	30.3	144	23
FG2-65/160A	15	20	36	40.5	114	35.0	144	28
FG2-65/200B	15	20	12	44	129	34.4	144	30.5
FG2-65/200A	18.5	25	12	50	143	38.4	150	36.5
FG2-65/200AR	22	30	12	57	136	47.0	156	42
FG2-65/250C	30	40	24	76	111	64.7	141	53
FG2-65/250B	37	50	24	87	120	74.3	150	62
FG2-65/250A	45	60	24	95	126	80.7	156	68
FG2-80/160D	11	15	30	25	171	19.1	240	10
FG2-80/160C	15	20	30	30	178	23.4	240	15
FG2-80/160B	18.5	25	30	35	185	27.7	240	20
FG2-80/160A	22	30	30	40	190	32.1	240	25
FG2-80/200B	30	40	30	56	166	46.5	219	34.5
FG2-80/200A	37	50	30	62	180	53.0	234	40
FG2-80/250B	45	60	36	77	170	65.9	216	54
FG2-80/250A	55	75	36	88.5	180	77.3	234	60
FG2-100/160C	15	20	60	30	220	20.3	300	12
FG2-100/160B	18.5	25	60	34	234	23.1	312	14.5
FG2-100/160A	22	30	60	38	250	26.4	330	17.5
FG2-100/200C	30	40	48	51	216	39.6	279	28
FG2-100/200B	37	50	48	57	228	44.5	294	33
FG2-100/200A	45	60	48	63	245	50.6	315	38
FG2-100/250B	55	75	48	75	250	62.0	309	48
FG2-100/250A	75	100	48	89	270	76.0	345	58

Q = Flow Rate

H = Total manometric head

Performance curves comply with EN ISO 9906 Grade 3B tolerance limits.

PERFORMANCE RANGE - n= 1450 min⁻¹

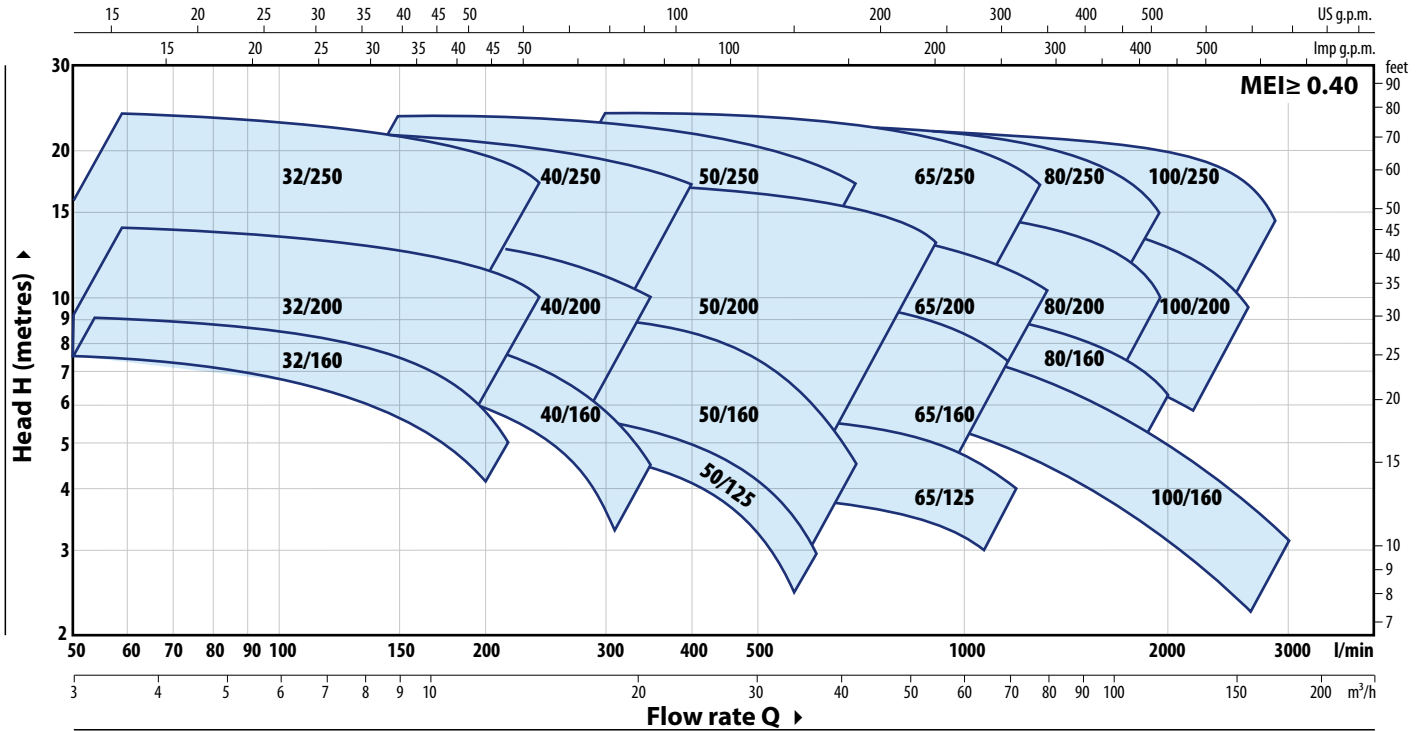

PERFORMANCE DATA - n= 1450 min⁻¹

TYPE	MOTOR TO BE COUPLED		PERFORMANCE n= 1450 min ⁻¹							
	kW	HP	Q m ³ /h	H m	Q m ³ /h	H m	Q m ³ /h	H m	Q m ³ /h	H m
FG4-32/160C	0.25	0.33	3	6	8	4.8	10.5	3.5		
FG4-32/160B	0.37	0.5	3	7.5	9.9	5.6	12	4.5		
FG4-32/160A	0.37	0.5	3	9	10.5	6.8	13.5	5		
FG4-32/200C	0.55	0.75	3	11	12	8.5	13.5	8		
FG4-32/200B	0.75	1	3	12.5	13.8	9.5	15	9		
FG4-32/200A	1.1	1.5	3	14	14.4	10.8	15	10.5		
FG4-32/200BH	0.75	1	3	11.3	8.4	9.6	9	9.2		
FG4-32/200AH	0.75	1	3	13.8	9	11.5	9.6	11		
FG4-32/250C	1.1	1.5	3	18.4	13.5	14.8	13.2	15		
FG4-32/250B	1.5	2	3	21.7	15	17.4	15	17.4		
FG4-32/250A	2.2	3	3	23.8	16.2	18.7	16.2	18.7		
FG4-40/160C	0.37	0.5	3	6.5	12	5.5	18	3.5		
FG4-40/160B	0.37	0.5	3	7.5	13.2	6.0	19.2	3.5		
FG4-40/160A	0.55	0.75	3	9	14.7	7.1	21	4.5		
FG4-40/200B	0.75	1	3	11.5	16.8	8.9	21	7		
FG4-40/200A	1.1	1.5	3	13.8	18.6	10.9	21	10		
FG4-40/250C	1.1	1.5	3	15.5	19.2	12.4	24	10		
FG4-40/250B	1.5	2	3	17.5	19.8	14.2	24	12		
FG4-40/250A	2.2	3	3	22	22.8	17.5	24	17		
FG4-50/125C	0.37	0.5	9	4	24.5	3.3	36	1.5		
FG4-50/125B	0.55	0.75	9	5	25.2	4.0	36	2		
FG4-50/125A	0.55	0.75	9	6	27	4.8	36	3		
FG4-50/160C	0.55	0.75	9	7	25	5	30	4		
FG4-50/160B	0.75	1	9	8	26.4	6.5	39	3.8		
FG4-50/160A	1.1	1.5	9	9.3	27.6	7.8	42	4.5		
FG4-50/200C	1.5	2	12	11	39.6	9.3	51	7.5		
FG4-50/200B	2.2	3	12	13	43.2	10.9	51	9.5		
FG4-50/200A	2.2	3	12	15	46.2	12.8	54	11.2		
FG4-50/200AR	3	4	12	17	48	14.5	54	13.2		
FG4-50/250D	1.1	1.5	9	12.5	25.5	10.1	39	5		
FG4-50/250C	1.5	2	9	14	27	11.2	42	5		
FG4-50/250B	2.2	3	9	18	30.6	14.6	42	10.5		
FG4-50/250A	2.2	3	9	20	33	16.3	42	13		
FG4-50/250AR	3	4	9	23.5	34.2	19.9	42	17		

TYPE	MOTOR TO BE COUPLED		PERFORMANCE n= 1450 min ⁻¹							
	kW	HP	Q m ³ /h	H m	Q m ³ /h	H m	Q m ³ /h	H m	Q m ³ /h	H m
FG4-65/125C	0.55	0.75	18	4	48	3.2	5.4	2.5		
FG4-65/125B	0.75	1	18	4.7	54	3.8	66	3		
FG4-65/125A	1.1	1.5	18	5.7	60	4.7	72	4		
FG4-65/160C	1.1	1.5	18	8	54.6	6.7	66	5.5		
FG4-65/160B	1.5	2	18	9.1	57	7.6	72	5.7		
FG4-65/160A	2.2	3	18	10.1	59.4	8.5	72	7		
FG4-65/200B	2.2	3	6	10.7	64.5	8.5	72	7.3		
FG4-65/200A	2.2	3	18	12	66	9.6	75	8.5		
FG4-65/200AR	3	4	18	14	68.4	11.2	78	10		
FG4-65/250C	3	4	12	19	55.5	16.2	70.5	13		
FG4-65/250B	4	5.5	12	21.8	58.8	18.8	75	15.5		
FG4-65/250A	5.5	7.5	12	23.5	60	20.6	78	17		
FG4-80/160D	1.5	2	18	6.3	84	4.8	120	2.5		
FG4-80/160C	2.2	3	18	7.5	88.8	5.7	120	3.8		
FG4-80/160B	2.2	3	18	8.8	94.8	6.8	120	5		
FG4-80/160A	3	4	18	10	99.6	7.7	120	6.2		
FG4-80/200B	4	5.5	18	14	92.4	10.9	108	9		
FG4-80/200A	5.5	7.5	18	15.5	97.5	12.6	114	10.5		
FG4-80/250B	5.5	7.5	18	19.5	90	16.1	108	13.5		
FG4-80/250A	7.5	10	18	22	84	19.9	117	15		
FG4-100/160C	2.2	3	24	7.5	110	5	144	3		
FG4-100/160B	2.2	3	24	8.3	117	5.7	156	3.5		
FG4-100/160A	3	4	24	10	124	6.9	168	4.7		
FG4-100/200C	4	5.5	24	12.7	111	9.6	138	7		
FG4-100/200B	5.5	7.5	24	14.2	117	10.9	144	8.5		
FG4-100/200A	5.5	7.5	24	15.8	123	12.6	156	9.5		
FG4-100/250B	7.5	10	24	18.5	117	15.9	156	11.5		
FG4-100/250A	9.2	12.5	24	22	126	19.3	174	13.5		

Q = Flow Rate

H = Total manometric head

Performance curves comply with EN ISO 9906 Grade 3B tolerance limits.

DIMENSIONS AND WEIGHT

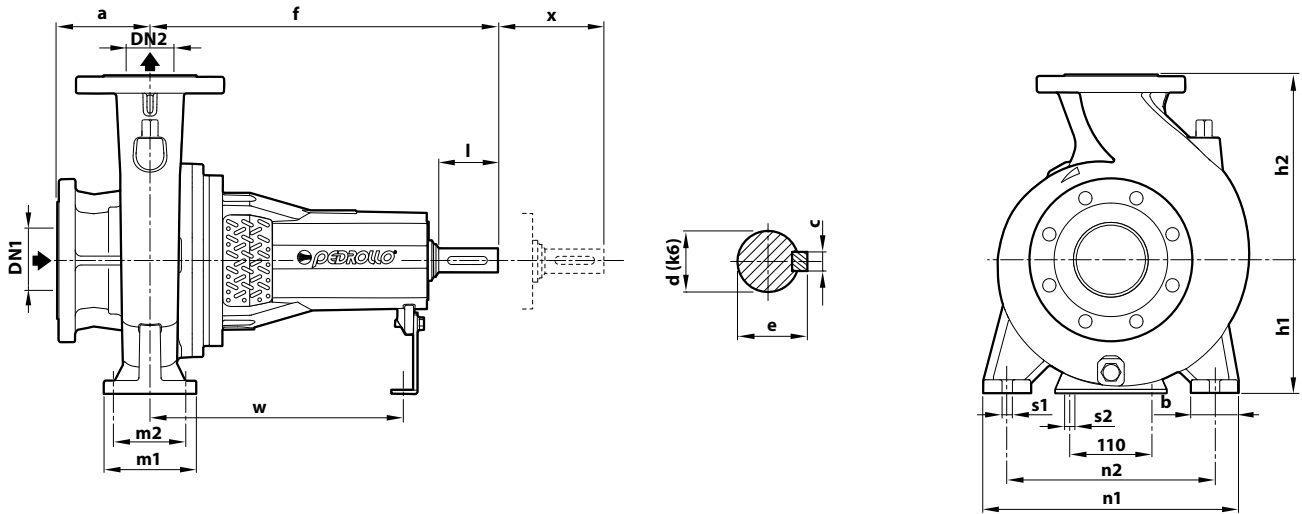

TYPE	PORTS		DIMENSIONS mm																	kg												
	DN1	DN2	a	f	h1	h2	b	m1	m2	n1	n2	s1	s2	w	x	l	d (k6)	c	e													
FG 32/160	50	32	80	360	132	160	55	96	71	240	190	14	14	260	100	50	24	8	27	33.0												
FG 32/200					160	180	55	95												210	160	38.1										
FG 32/200H					160	180	55	95												240	190	36.9										
FG 32/250					180	225	65	125												95	320	250	53.0									
FG 40/125	65	40	80	360	112	140	50	100	70	240	190	14	14	260	100	50	24	8	27	30.4												
FG 40/160					132	160														50	100	70	240	190	34.1							
FG 40/200					160	180	55													100	70	265	212	40.2								
FG 40/250					180	225	65													125	95	320	250	59.2								
FG 50/125	65	50	100	360	132	160	50	100	70	240	190	14	14	260	100	50	24	8	27	33.0												
FG 50/160					160	180	55													100	70	265	212	38.3								
FG 50/200					160	200	50													100	70	320	250	50.3								
FG 50/250					180	225	65													125	95	320	250	57.0								
FG 65/125	80	65	100	360	160	180	65	125	95	280	212	14	14	260	100	50	24	8	27	45.2												
FG 65/160					160	200	65													125	95	320	250	48.0								
FG 65/200					180	225	65													125	95	320	250	55.1								
FG 65/250					470	200	250													80	160	120	360	280	18	340	140	80	32	10	35	82.4
FG 80/160	100	80	125	360	360	180	225	65	125	95	320	250	14	14	260	100	50	24	8	27	53.0											
FG 80/200					470	180	250	65													125	95	345	280	14	340	140	80	32	10	35	72.0
FG 80/250					200	280	80	160													120	400	315	18	340	140	80	32	10	35	91.1	
FG 100/160					360	200	280	80													160	120	360	280	18	260	140	50	24	8	27	76.3
FG 100/200	125	100	140	470	200	280	80	160	120	360	280	18	14	340	100	80	32	10	35	82.1												
FG 100/250					225	280	80													160	120	400	315	18	340	100	80	32	10	35	96.0	

PORT FLANGES

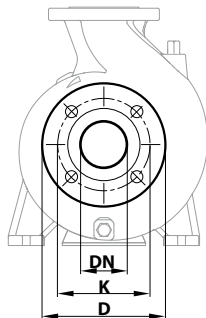

DN FLANGE	D	K	HOLES	
			N°	Ø (mm)
32	140	100	4	18
40	150	110		
50	165	125		
65	185	145		
80	200	160		
100	220	180	8	18
125	250	210		

COUNTER-FLANGE

(CAN BE ORDERED SEPARATELY)

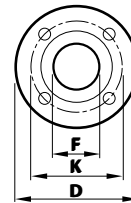

DN FLANGE	F	D	K	HOLES	
				N°	Ø (mm)
32	1¼"	140	100	4	18
40	1½"	150	110		
50	2"	165	125		
65	2½"	185	145		
80	3"	200	160		
100	4"	220	180	8	18
125	5"	250	210		

-  Clean water
-  Domestic use
-  Agricultural use



INSTALLATION AND USE

FLUID SOLAR pumps are engineered to draw clean water from wells using power from photovoltaic modules.

They feature a high-efficiency motor with integrated electronic control that adjusts the motor's speed based on the solar energy available.

This ensures optimal performance: high speed and efficiency in sunny conditions, and lower speed with reduced efficiency on cloudy days.

These pumps utilize a high-efficiency, oil-bathed, permanent magnet motor for enhanced performance and durability.

APPLICATION LIMITS

- Liquid temperature up to **+35 °C**
- Maximum sand content **200 g/m³**
- Capable of operating at depths of up to **100 metres** below water level

PATENTS - TRADEMARKS - DESIGNS

- Patent No. 0001413386, EP2419642
- Patent No. EP2300717
- Patent No. 102021000030575
- FLUID SOLAR® Registered trademark No. 001516301

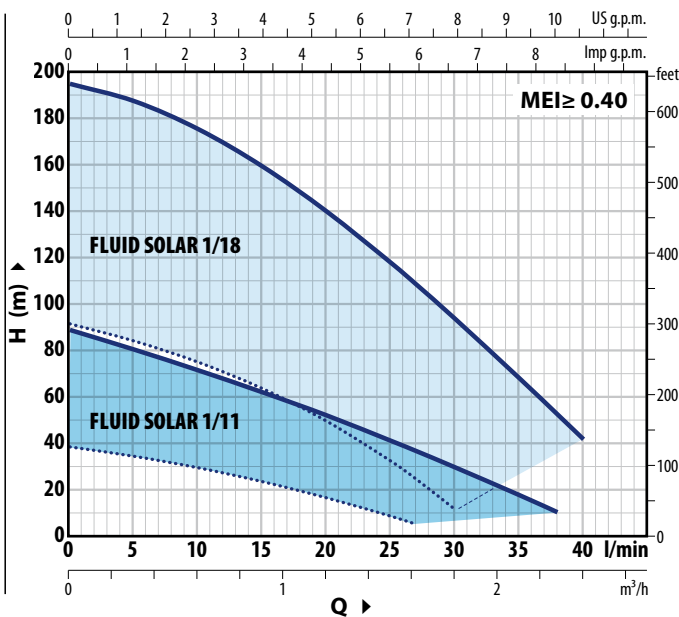

FLUID SOLAR 1/11

POWER CONSUMPTION P₁ **750 W**

Q	0	0.3	0.6	0.9	1.2	1.5	1.6	1.8	2.1	2.3
m ³ /h	0	5	10	15	20	25	27	30	35	38
l/min	0	5	10	15	20	25	27	30	35	38
H metres	89	80.5	71.5	62	52	41	36.5	29.5	17.5	10
H feet	38	34	29.1	23.2	16.3	8.5	5			



Performance with photovoltaic modules for a total rated power of 980 Wp

FLUID SOLAR 1/18

POWER CONSUMPTION P₁ **1500 W**

Q	0	0.3	0.6	1.2	1.5	1.62	1.8	2.1	2.4
m ³ /h	0	5	10	20	25	27	30	35	40
l/min	0	5	10	20	25	27	30	35	40
H metres	194.5	187	175	139.5	117.5	108	93.5	68	41.5
H feet	91.5	84	74.8	49.4	32.3	24.5	11.5		

Performance with photovoltaic modules for a total nominal power of 1960 Wp

-  Performance under 1000 W/m² Solar Irradiation and 100 VDC No-load Voltage from Photovoltaic Modules
-  Performance under 300 W/m² Solar Irradiation and 70 VDC No-load Voltage from Photovoltaic Modules

The performance curves shown above are based on photovoltaic modules positioned towards the SOUTH (or NORTH for installations in the Southern Hemisphere). The angle of inclination is adjusted according to the latitude of the installation site to optimize performance.

CURVES AND PERFORMANCE DATA

Performance curves comply with EN ISO 9906 Grade 3B tolerance limits.

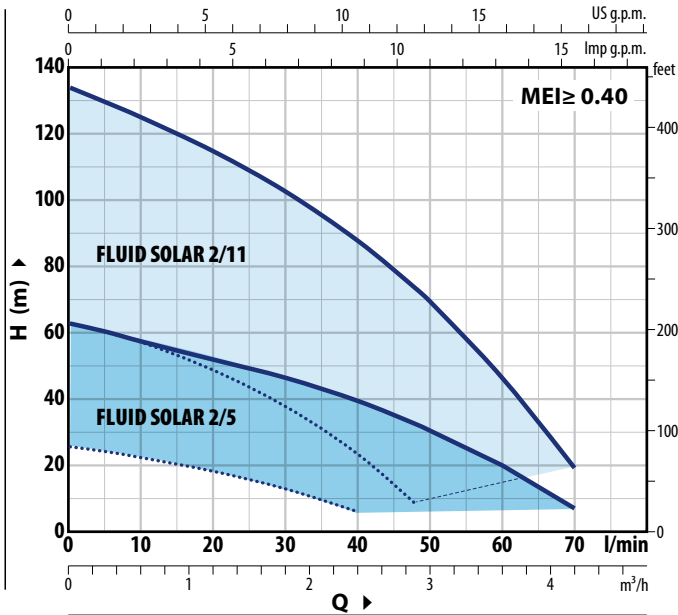

FLUID SOLAR 2/5

POWER CONSUMPTION P₁ **750 W**

Q	0	0.3	0.6	1.2	1.8	2.4	2.88	3	3.6	4.2
m ³ /h	0	0.3	0.6	1.2	1.8	2.4	2.88	3	3.6	4.2
l/min	0	5	10	20	30	40	48	50	60	70
H metres	63	60.5	57.5	52	46.5	39.5	32.5	30.5	20	7
	26	24.5	22.6	18.4	13	6				

Performance with photovoltaic modules for a total rated power of 980 Wp

FLUID SOLAR 2/11

POWER CONSUMPTION P₁ **1500 W**

Q	0	0.3	0.6	1.2	1.8	2.4	2.88	3	3.6	4.2
m ³ /h	0	0.3	0.6	1.2	1.8	2.4	2.88	3	3.6	4.2
l/min	0	5	10	20	30	40	48	50	60	70
H metres	134	129.5	125	115	102.5	88	73.5	69.5	47	19.5
	63	60.5	57.4	49.3	38.1	23.2	8			

Performance with photovoltaic modules for a total nominal power of 1960 Wp

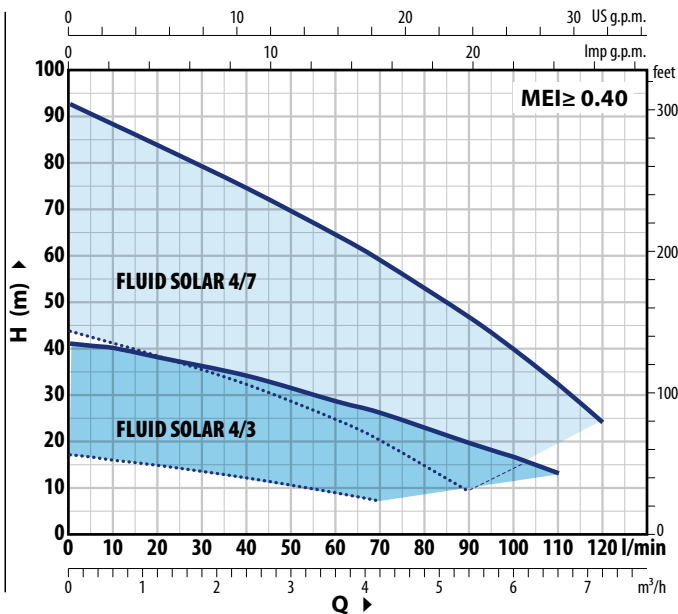

FLUID SOLAR 4/3

POWER CONSUMPTION P₁ **750 W**

Q	0	0.3	0.6	1.2	2.4	3.6	4.2	5.4	6	6.6
m ³ /h	0	0.3	0.6	1.2	2.4	3.6	4.2	5.4	6	6.6
l/min	0	5	10	20	40	60	70	90	100	110
H metres	41	40.5	40	38	34	28.5	26	19.5	16.5	13
	17	16.5	15.8	14.7	12	8.8	7			

Performance with photovoltaic modules for a total rated power of 980 Wp

FLUID SOLAR 4/7

POWER CONSUMPTION P₁ **1500 W**

Q	0	0.3	0.6	1.2	2.4	3.6	4.2	5.4	6	6.6	7.2
m ³ /h	0	0.3	0.6	1.2	2.4	3.6	4.2	5.4	6	6.6	7.2
l/min	0	5	10	20	40	60	70	90	100	110	120
H metres	93	90.5	88.5	84	74.5	64.5	59	46.5	40	32	24
	44	42.5	41.1	38.3	32.2	24.6	20.1	9			

Performance with photovoltaic modules for a total nominal power of 1960 Wp

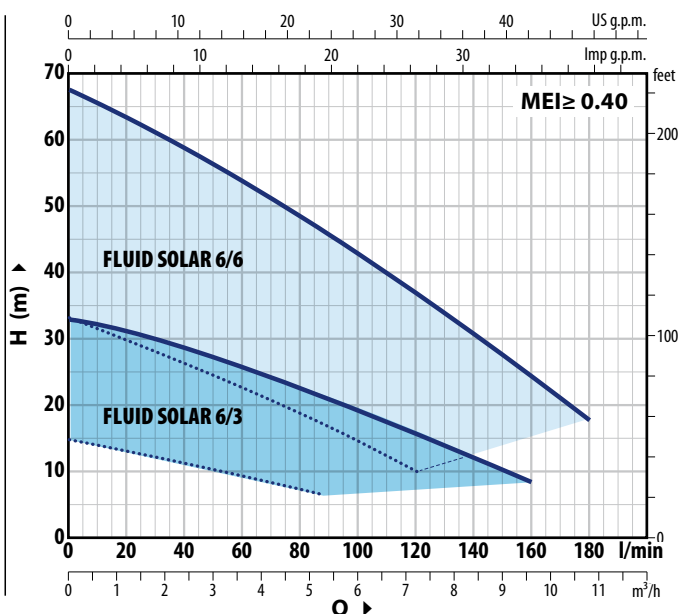

FLUID SOLAR 6/3

POWER CONSUMPTION P₁ **750 W**

Q	0	0.3	1.2	2.4	3.6	4.8	5.4	6	7.2	7.2	8.4	9.6
m ³ /h	0	0.3	1.2	2.4	3.6	4.8	5.4	6	7.2	7.2	8.4	9.6
l/min	0	5	20	40	60	80	90	100	120	120	140	160
H metres	33	32.5	31.5	29	26	22.5	20.5	19	15	15	11.5	8.5
	15	14.5	12.8	11	9.4	7.5	6.5					

Performance with photovoltaic modules for a total rated power of 980 Wp

FLUID SOLAR 6/6

POWER CONSUMPTION P₁ **1500 W**

Q	0	0.3	1.2	2.4	3.6	4.8	5.4	6	7.2	8.4	9.6	10.8
m ³ /h	0	0.3	1.2	2.4	3.6	4.8	5.4	6	7.2	8.4	9.6	10.8
l/min	0	5	20	40	60	80	90	100	120	140	160	180
H metres	68	67	63.5	59	54	48.5	46	43	37	31	24.5	18
	33.5	32.5	30	26.5	22.8	18.9	16.8	14.7	10			

Performance with photovoltaic modules for a total nominal power of 1960 Wp

FLUID SOLAR

STANDARD EQUIPMENT

P₁ = 750 W

ELECTRICAL PANEL

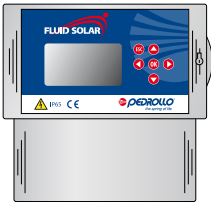

CONNECTORS

No. 1 male connector type **SMK**

No. 1 female connector type **SMK**

P₁ = 1500 W

ELECTRICAL PANEL

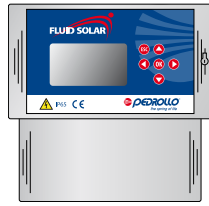

CONNECTORS

No. 1 male connector type **SMK**

No. 1 female connector type **SMK**

No. 1 Y-connector female/male type **MC4**

No. 1 male-female Y-connector type **MC4**

EXAMPLES OF INSTALLATION

FLUID SOLAR 1/11 - 2/5 - 4/3 - 6/3

- ✳ To achieve maximum rated performance, the pump requires **photovoltaic modules** with a total rated power of **980 Wp** or higher.
- ✳ The pump can run on lower-power photovoltaic modules than recommended, but with reduced performance.
- ✳ Each module must have an open-circuit voltage between **35 - 55VDC**.

FLUID SOLAR 1/18 - 2/11 - 4/7 - 6/6

- ✳ To achieve maximum rated performance, the pump requires photovoltaic modules with a total rated power of **1960 Wp** or higher.
- ✳ The pump can run on lower-power photovoltaic modules than recommended, but with reduced performance.
- ✳ Each module must have an open-circuit voltage between **35 and 55VDC**.

P₁=750 W

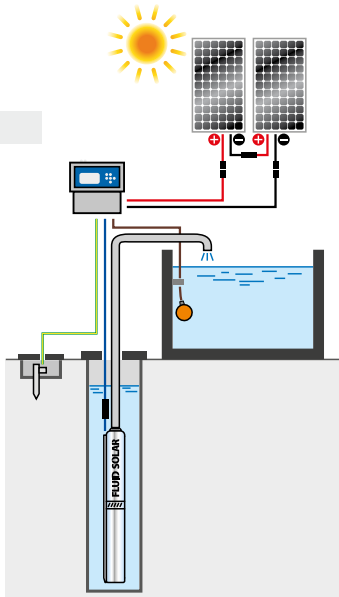

P₁=1500 W

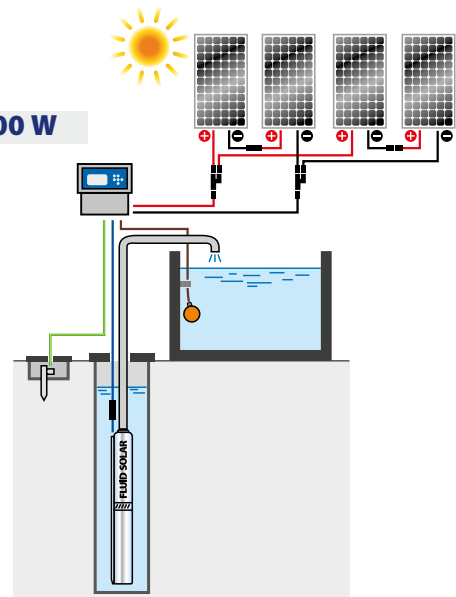

DIMENSIONS AND WEIGHT

P₁ = 750 W

TYPE	PORT DN	DIMENSIONS mm		kg *
		Ø	h	
FLUID SOLAR 1/11	1 1/4"	100	746	14.2
FLUID SOLAR 2/5			625	13.3
FLUID SOLAR 4/3			601	13.0
FLUID SOLAR 6/3			621	12.5

P₁ = 1500 W

FLUID SOLAR 1/18	1 1/4"	100	956	18.5
FLUID SOLAR 2/11			816	17.7
FLUID SOLAR 4/7			771	16.8
FLUID SOLAR 6/6			785	16.6

(* weight of pump with control panel)

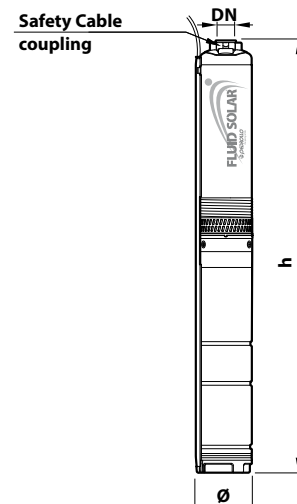

MATERIALS AND COMPONENTS

1 Delivery port and pump jacket Stainless steel **AISI 304** with thread according to ISO 228/1

2 Pump bearing EPDM

3 Impellers Delrin®

4 Diffusers Noryl™

5 Stadium boxes Stainless steel **AISI 304**

6 Pump shaft Stainless steel **AISI 304**

7 Cable sheath Stainless steel **AISI 304**

8 Filter Stainless steel **AISI 304**

9 Coupling motor bracket Technopolymer and brass

10 Motor shaft Stainless steel **AISI 431**

11 Motor sleeve Stainless steel **AISI 304**

12 Mechanical seal

Seal	Shaft	Materials
ST4-16	Ø 16 mm	Ceramic / Graphite / NBR

13 Vectoral

14 Electric motor

- High-efficiency permanent magnet oil filled motor (non-toxic food-safe oil), rewindable.
- Continuous running duty S1
- Insulation: Class F
- Protection rating: IP X8

15 Compensating diaphragm

16 Power cord

Cable approved for use in drinking water by ACS, KTW, WRAS

※ Standard length 2.2 metres

※ Standard equipment: RPS2 cable splice kit

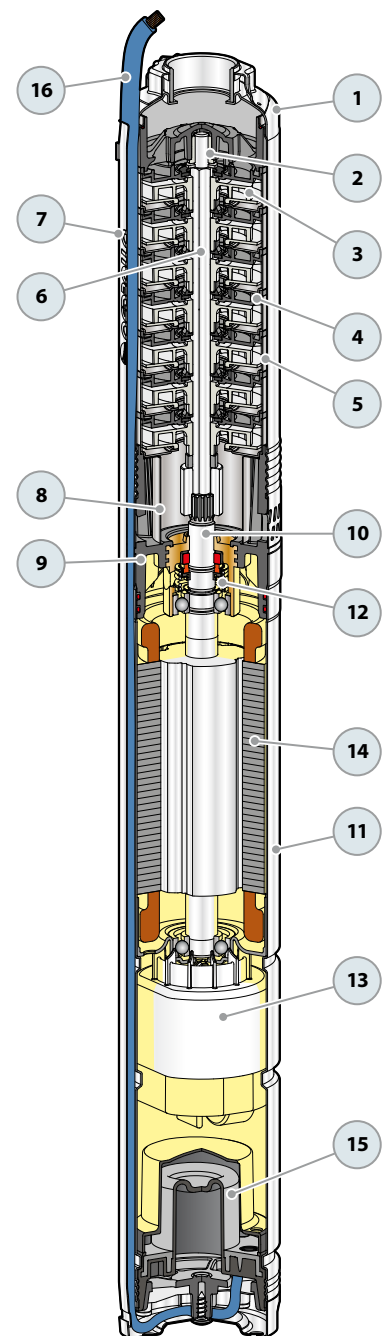



Clean water



Civil use



Domestic use



Agricultural use



※ **Ready-to-install stainless steel submersible pump equipped with an integrated capacitor and thermal protector.**

※ **Patented hydraulics featuring fully independent, floating impellers, ensuring minimal impact from sand on pump performance.**

※ **These hydraulics have a minimum efficiency index (MEI) that far exceeds ErP requirements.**

※ **Outstanding performance .**

※ **Comes with a 20 m power cable.**

PERFORMANCE RANGE

- Flow rate up to **200 l/min** (12 m³/h)
- Head up to **140 m**

INSTALLATION AND USE

Designed to draw water from clean wells, even in the presence of sand (up to **200 g/m³**).

With their high efficiency, reliability, and ease of installation, they are highly recommended for domestic, commercial, and agricultural applications. They are ideal for automatic water distribution alongside pressure tanks, irrigation systems, and more.

APPLICATION LIMITS

- Liquid temperature up to **+35 °C**
- Maximum sand content **200 g/m³**
- Capable of operating at depths of up to **100 metres** below water level (with an appropriately sized power cable)
- Vertical and horizontal operation
- Starts per hour: **20** at regular intervals

AVAILABLE UPON REQUEST

- ※ **30 metres** long power cable
- ※ Different voltage requirements 60 Hz frequency

PERFORMANCE RANGE

50 Hz

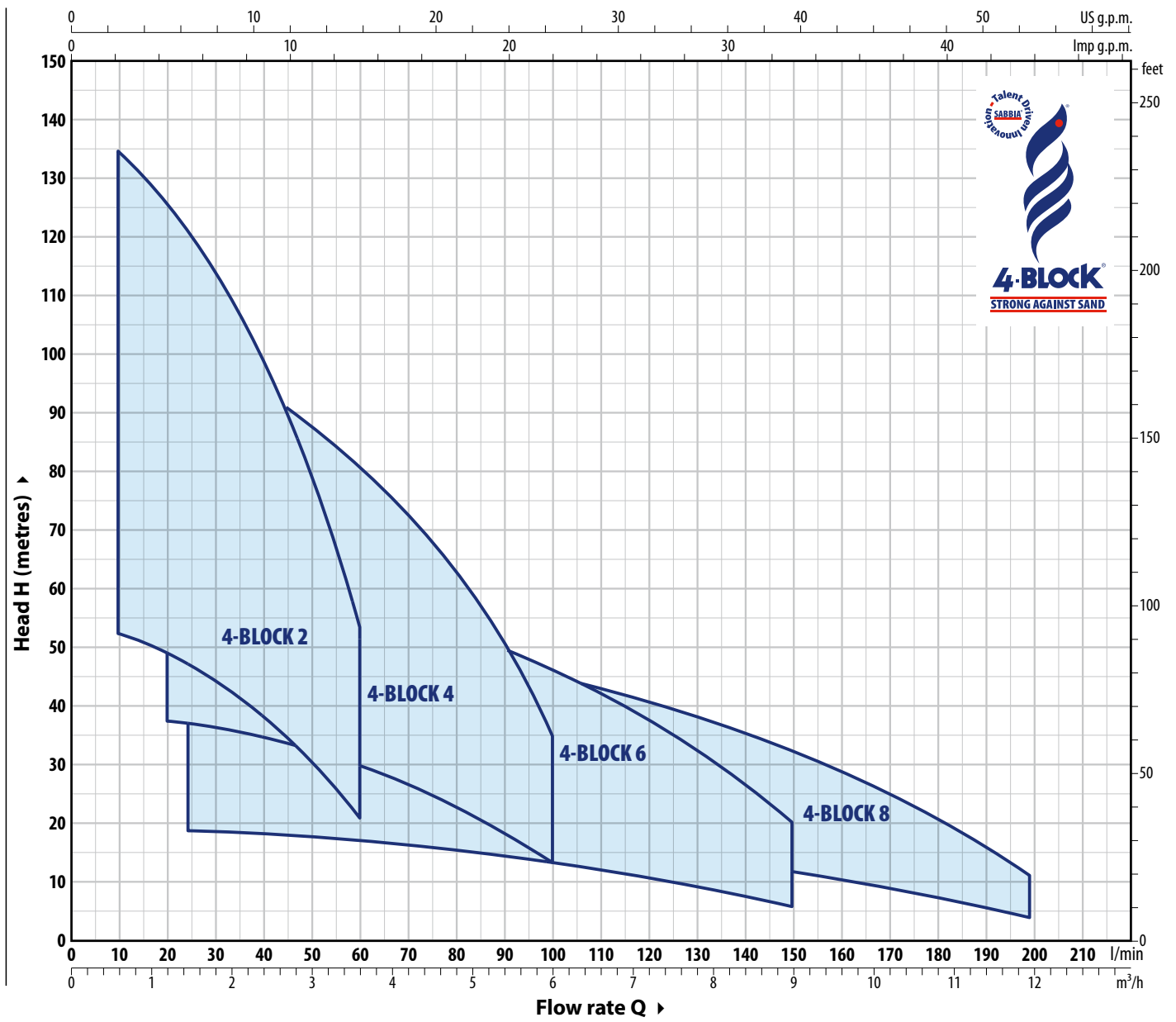

PATENTS - TRADE MARKS - MODELS

- European Patents No. EP3123031, EP2419642
- Patent No. 102021000030575
- **4-BLOCK**® is a registered trademark No. 018702380



4-BLOCK

4" Close-coupled electric submersible pumps

PERFORMANCE RANGE

50 Hz

4-BLOCK 2

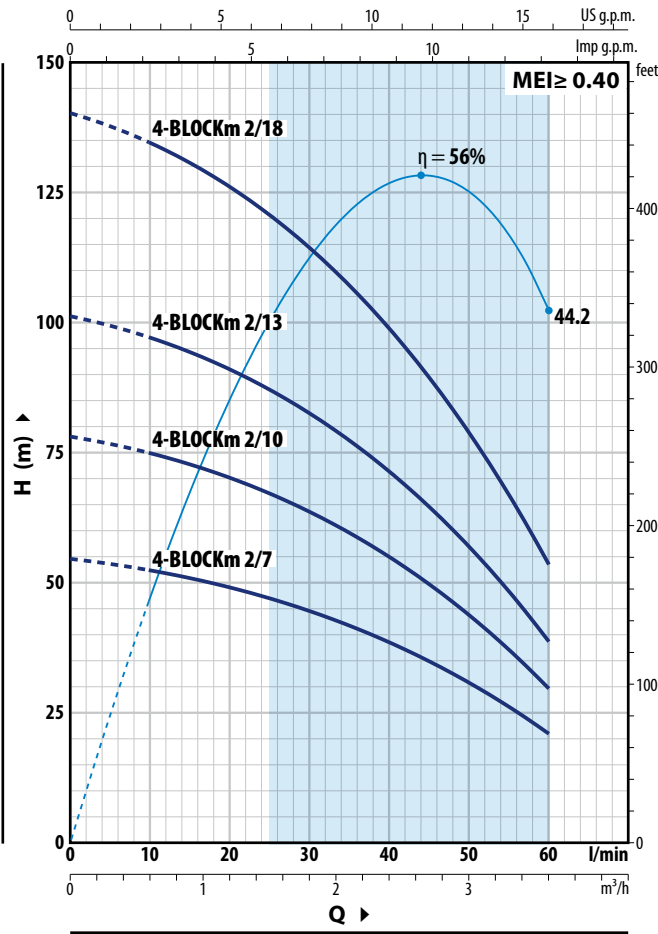

4-BLOCK 4

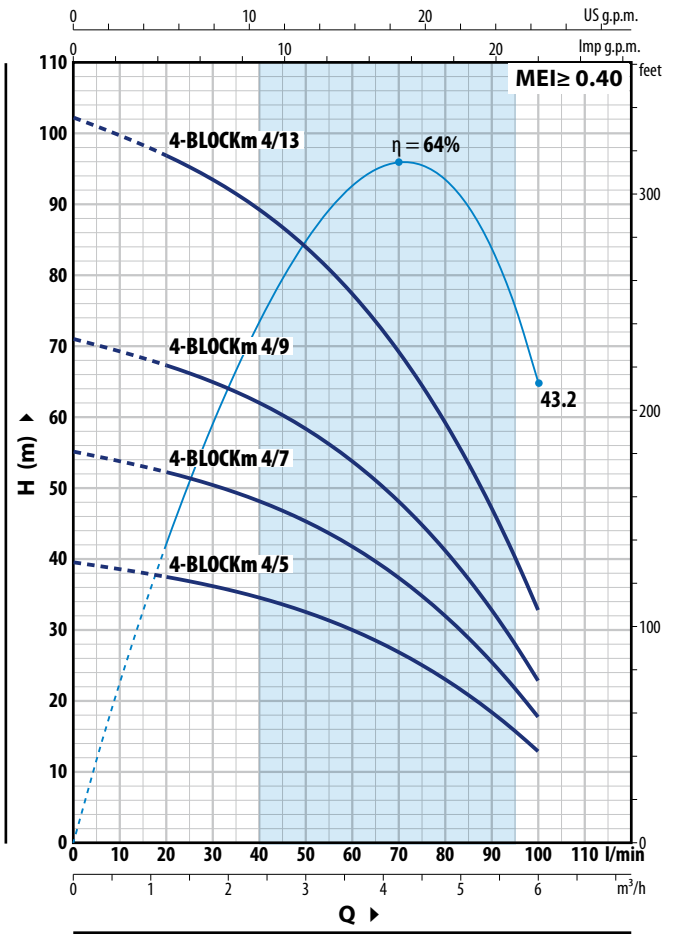

4-BLOCK 2

TYPE	POWER (P ₂)		Q	Flow rate (Q)								
	kW	HP		m ³ /h	l/min	0	0.6	1.2	1.8	2.4	3	3.6
Single-phase				0	10	20	30	40	50	60		
4-BLOCKm 2/7	0.37	0.50	H metres	54.5	52.5	49	44.5	38.5	30.5	21		
4-BLOCKm 2/10	0.55	0.75		78	75	70	63.5	55	44	29.5		
4-BLOCKm 2/13	0.75	1		101	97	91	83	71	57	38.5		
4-BLOCKm 2/18	1.1	1.5		140	135	126	114	99	79	53.5		

4-BLOCK 4

TYPE	POWER (P ₂)		Q	Flow rate (Q)								
	kW	HP		m ³ /h	l/min	0	1.2	1.5	2.4	3.6	4.5	6
Single-phase				0	20	25	40	60	75	100		
4-BLOCKm 4/5	0.37	0.50	H metres	39.5	37.5	36.5	34.5	30	24.8	12.5		
4-BLOCKm 4/7	0.55	0.75		55	52	51.5	48	41.5	34.5	17.5		
4-BLOCKm 4/9	0.75	1		71	67	66	62	53.5	44.5	22.5		
4-BLOCKm 4/13	1.1	1.5		102	97	95	89	77	64.5	32.5		

Q = Flow rate H = Total manometric head

Performance curves comply with EN ISO 9906 Grade 3B tolerance limits.

PERFORMANCE RANGE

50 Hz

4-BLOCK 6

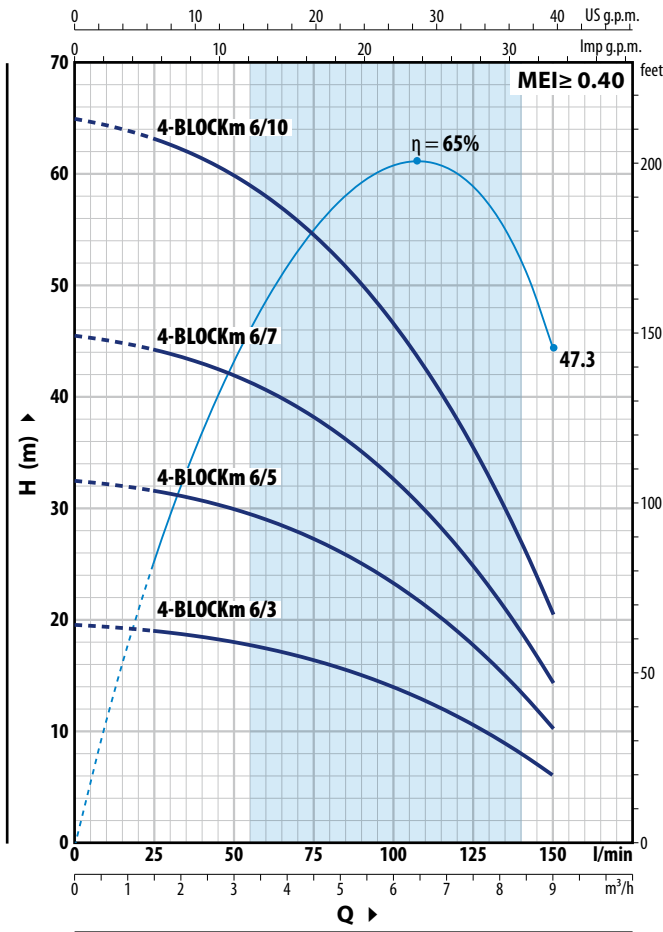

4-BLOCK 8

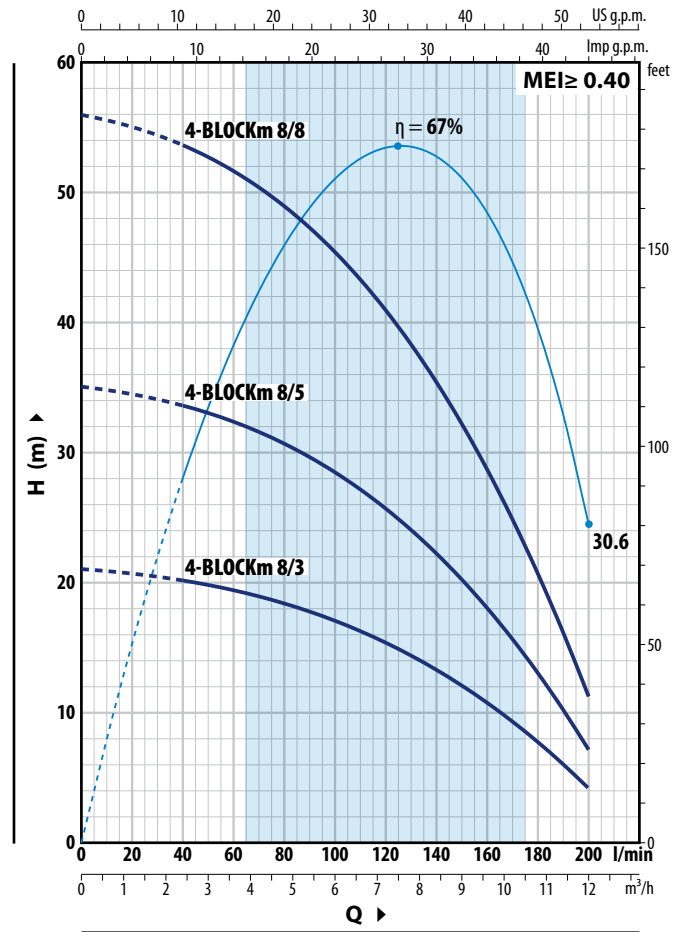

4-BLOCK 6

TYPE	POWER (P ₂)		Q	Flow rate									
	kW	HP		m ³ /h	l/min	0	1.5	2.4	3.6	4.5	6.0	7.5	9.0
Single-phase				0	25	40	60	75	100	125	150		
4-BLOCKm 6/3	0.37	0.50	H metres	19.5	19	18.4	17.4	16.4	14	10.6	6		
4-BLOCKm 6/5	0.55	0.75		32.5	31.5	30.5	29	27.5	23.3	17.7	10		
4-BLOCKm 6/7	0.75	1		45.5	44	43	40.5	38	32.5	24.8	14.5		
4-BLOCKm 6/10	1.1	1.5		65	63	61.5	58	54.5	46.5	35.5	20.5		

4-BLOCK 8

TYPE	POWER (P ₂)		Q	Flow rate									
	kW	HP		m ³ /h	l/min	0	2.4	3.6	4.5	6.0	7.5	9.0	10.5
Single-phase				0	40	60	75	100	125	150	175	200	
4-BLOCKm 8/3	0.55	0.75	H metres	21	20	19.4	18.7	17.1	14.9	12.1	8.6	4	
4-BLOCKm 8/5	0.75	1		35	33.5	32.5	31	28.5	24.8	20.2	14.3	7	
4-BLOCKm 8/8	1.1	1.5		56	53.5	51.5	50	45.5	39.5	32.5	22.9	11.5	

Q = Flow rate H = Total manometric head

Performance curves comply with EN ISO 9906 Grade 3B tolerance limits.

MATERIALS AND COMPONENTS

1 Delivery port and pump jacket Stainless steel **AISI 304** with thread according to ISO 228/1

2 Pump bearing EPDM

3 Impellers Delrin®

4 Diffusers Noryl™

5 Stadium boxes Stainless steel **AISI 304**

6 Pump shaft Stainless steel **AISI 304**

7 Cable sheath Stainless steel **AISI 304**

8 Filter Stainless steel **AISI 304**

9 Coupling motor bracket Technopolymer and brass

10 Motor shaft Stainless steel **AISI 431**

11 Motor sleeve Stainless steel **AISI 304**

12 Mechanical seal

Seal	Shaft	Materials
ST4-16	Ø 16 mm	Ceramic / Graphite / NBR

13 Capacitor

14 Electric motor

- Specially dimensioned submersible rewindable oil filled motor, suitable for continuous service (non-toxic food-safe oil).
- Single-phase 220-230 V - 50 Hz
- Built-in motor capacitor
- Thermal motor protection incorporated in the winding
- Continuous running duty S1
- Insulation: Class F
- Protection rating: IP X8

15 Compensating diaphragm

16 Power cord

⇒ **DRINCABLE® HRC** certified for use with drinking water meant for human consumption by the **ACS** according to XP P 41-250, approval no. 18 MAT NY 156

Standard length **20 metres**

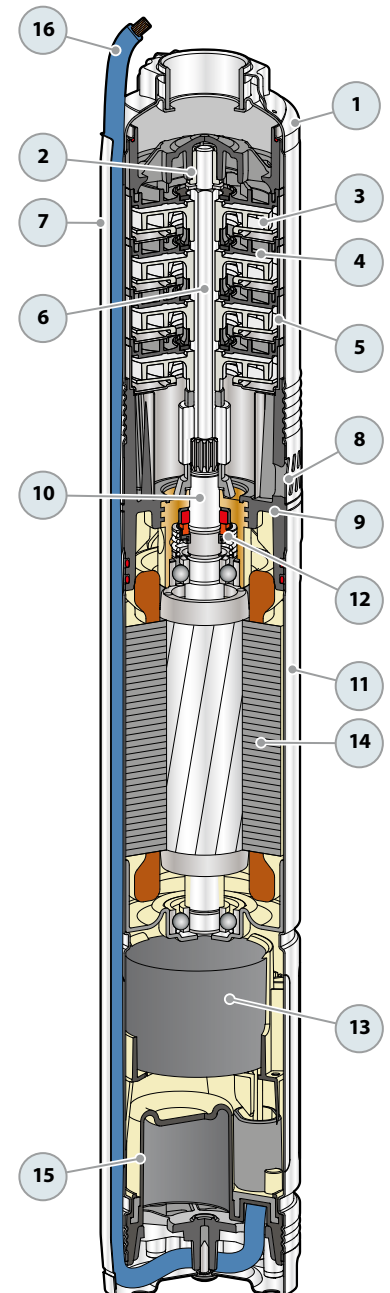

DIMENSIONS AND WEIGHT

TYPE	PORT DN	DIMENSIONS mm			kg
		NO. STAGES	Ø	h	
Single-phase					1~
4-BLOCKm 2/7	1 1/4"	7	100	617	11.4
4-BLOCKm 2/10		10		677	12.3
4-BLOCKm 2/13		13		757	13.9
4-BLOCKm 2/18		18		907	17.0
4-BLOCKm 4/5		5		602	11.5
4-BLOCKm 4/7		7		652	12.1
4-BLOCKm 4/9		9		722	13.3
4-BLOCKm 4/13		13		872	16.4
4-BLOCKm 6/3		3		572	11.4
4-BLOCKm 6/5		5		635	12.0
4-BLOCKm 6/7		7		718	13.2
4-BLOCKm 6/10		10		862	16.4
4-BLOCKm 8/3		3		572	12.0
4-BLOCKm 8/5		5		655	12.6
4-BLOCKm 8/8		8		799	15.8

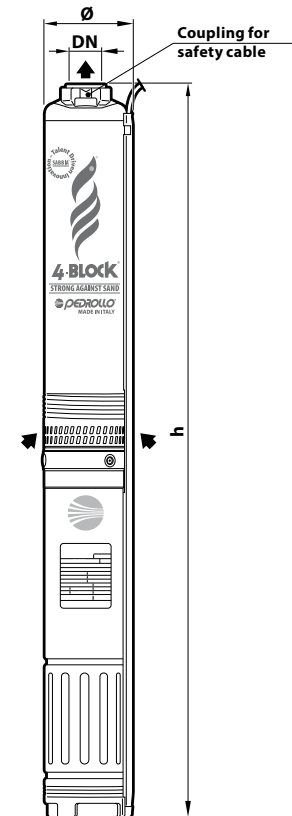

ABSORPTION

TYPE	VOLTAGE
Single-phase	230 V
4-BLOCKm – 0.37 kW	3.5 A
4-BLOCKm – 0.55 kW	4.4 A
4-BLOCKm – 0.75 kW	6.1 A
4-BLOCKm – 1.1 kW	8.0 A

PALLET CAPACITY

TYPE	NO. OF PUMPS
Single-phase	
4-BLOCKm 2	55
4-BLOCKm 4	55
4-BLOCKm 6	55
4-BLOCKm 8	55

Typical installation

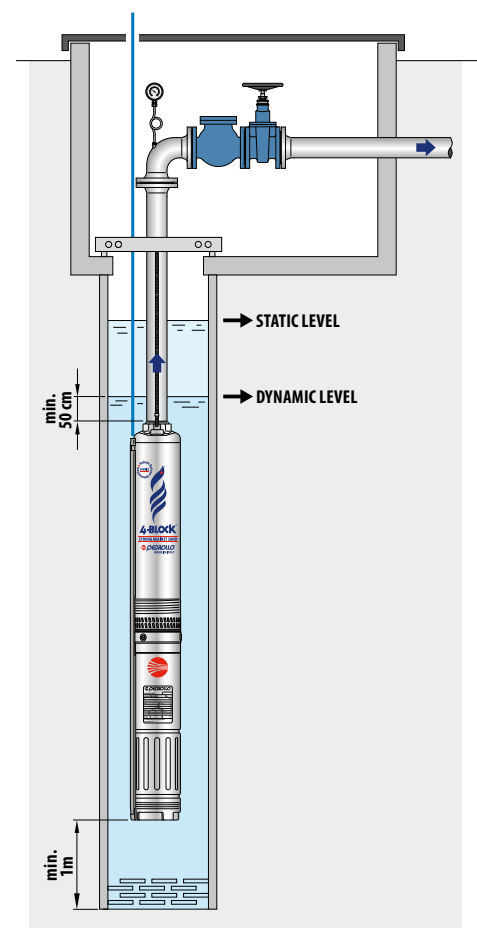



PERFORMANCE RANGE

- Flow rate up to **50 l/min** (3.0 m³/h)
- Head up to **75 m**

INSTALLATION AND USE

Ready-to-install cost-effective submersible pump, equipped with an integrated capacitor and thermal over-load protector.

Designed to transfer clean water free from abrasive particles and liquids that will not damage the pump's components.

Compact and cost-effective, it is suitable for domestic applications. It works seamlessly with small-sized pressure tanks, offering an ideal setup for all irrigation requirements.

APPLICATION LIMITS

- Liquid temperature up to **+40 °C**
- Depth of use up to **40 m** below water level (with an appropriately sized power cable)
- Vertical and horizontal operation

AVAILABLE UPON REQUEST

- ✘ **30 metres** long power cable
- ✘ Different voltage requirements 60 Hz frequency

CURVES AND PERFORMANCE DATA – HS=0 m

50 Hz

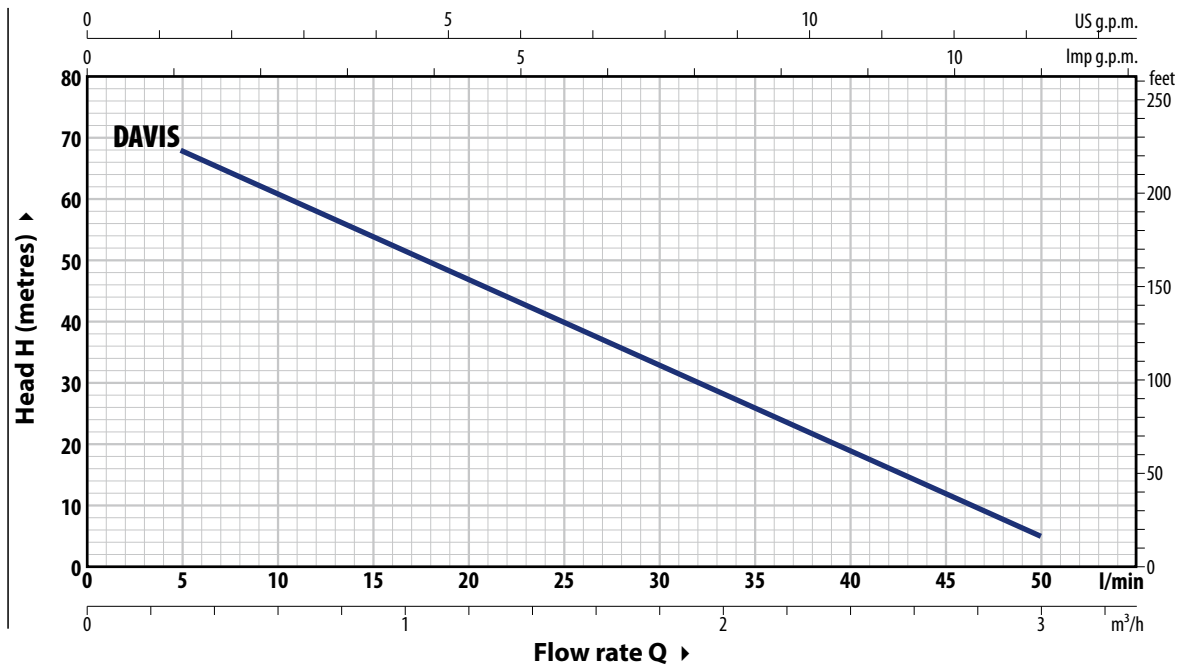

TYPE	POWER (P ₂)		Q	Flow rate												
	kW	HP		m ³ /h	0	0.3	0.6	0.9	1.2	1.5	1.8	2.1	2.4	2.7	3.0	
Single-phase			l/min	0	5	10	15	20	25	30	35	40	45	50		
DAVIS®	0.75	1	H metres	75	68	61	54	47	40	33	26	19	12	5		

Q = Flow rate H = Total manometric head

Performance curves comply with EN ISO 9906 Grade 3B tolerance limits.

MATERIALS AND COMPONENTS

1	Delivery port	Stainless steel AISI 304 complete with threaded delivery port in compliance with ISO 228/1	
2	Sealing cover	Brass	
3	Impeller	Brass, radial peripheral vane type	
4	Motor sleeve	Stainless steel AISI 304	
5	Motor shaft	Stainless steel AISI 431	
6	Two mechanical seals separated by an oil chamber	Type	Materials
		Shaft	
		Ø 14 mm	Ceramic / Graphite / NBR
		Ø 14 mm	Ceramic / Silicon carbide / NBR
7	Capacitor		
8	Electric motor	<ul style="list-style-type: none"> – Submersible PEDROLLO motor, suitable for continuous duty (with dry, rewindable stator). – Single-phase 220-230 V - 50 Hz – Built-in motor capacitor – Thermal motor protection incorporated in the winding – Continuous running duty S1 – Insulation: Class F – Protection rating: IP X8 	
9	✳ Power cord	<ul style="list-style-type: none"> ➡ DRINCABLE® HRC certified for use with drinking water meant for human consumption by the ACS according to XP P 41-250, approval no. 18 MAT NY 156 Standard length 20 metres 	

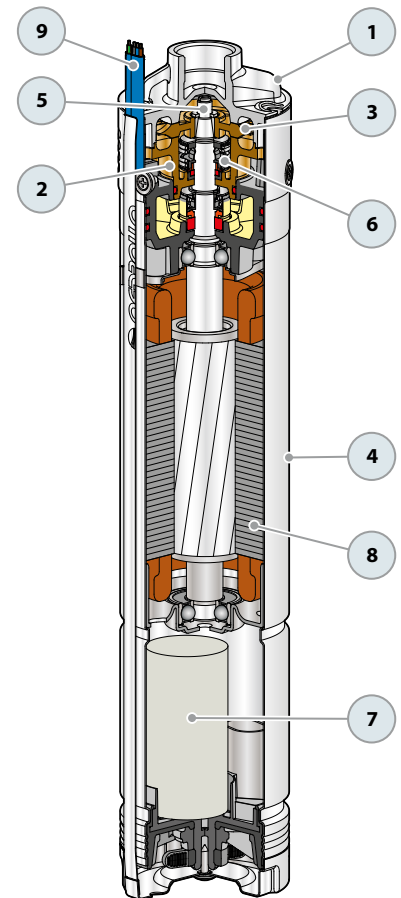

ABSORPTION

TYPE	VOLTAGE
Single-phase	230 V
DAVIS®	5.7 A

DIMENSIONS AND WEIGHT

TYPE	PORT	DIMENSIONS mm		kg
		DN	h	
Single-phase	DN	Ø	h	
DAVIS®	1"	101	470	12.6

PALLET CAPACITY

TYPE	NO. OF PUMPS
Single-phase	
DAVIS®	60

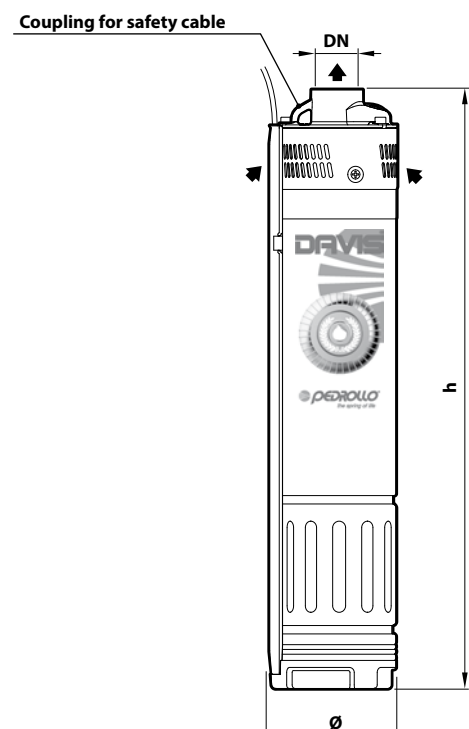



Clean water

Domestic use

Civil use



PERFORMANCE RANGE

- Flow rate up to **120 l/min** (7.2 m³/h)
- Head up to **267 m**

INSTALLATION AND USE

3-inch submersible pumps are designed to transfer clean water, making them perfect for household use, irrigation, and small community water systems.

KEY FEATURES

The increased efficiency of 3SR pumps not only saves electricity but also offers economic advantages. Their small size and light build allow for easy installation in wells 3 inches wide or more.

With a blend of hydraulic parts and a high-efficiency motor, 3SR pumps excel in the 3-inch category, capable of handling water with up to **150 g/m³** of sand.

ELECTRIC MOTOR

- **Rewindable** motor in oil bath (non-toxic food-safe oil) 2-pole, 50 Hz
- Voltage:
 - single-phase 230 V
 - three-phase 400 V
- Continuous running duty **S1**
- Insulation: Class F
- Protection rating: IP 68
- Shaft and sleeve: **AISI 304** stainless steel
- Flange coupling dimensions to NEMA standard
- Connector with power cable from:
 - **1.5 m** for power up to 0.75 kW
 - **2.0 m** for power ratings from 1.1 kW

APPLICATION LIMITS

- Liquid temperature up to **+35 °C**
- Maximum sand content **150 g/m³**
- Capable of operating at depths of up to **100 metres** below water level (with an appropriately sized power cable)
- Vertical operation
- Starts per hour: **20** at regular intervals
- Minimum motor cooling flow **8 cm/s**

AVAILABLE UPON REQUEST

- ✘ **10, 20, 30 or 40 metres** long power cable
- ✘ Different voltage requirements 60 Hz frequency

PERFORMANCE RANGE

50 Hz

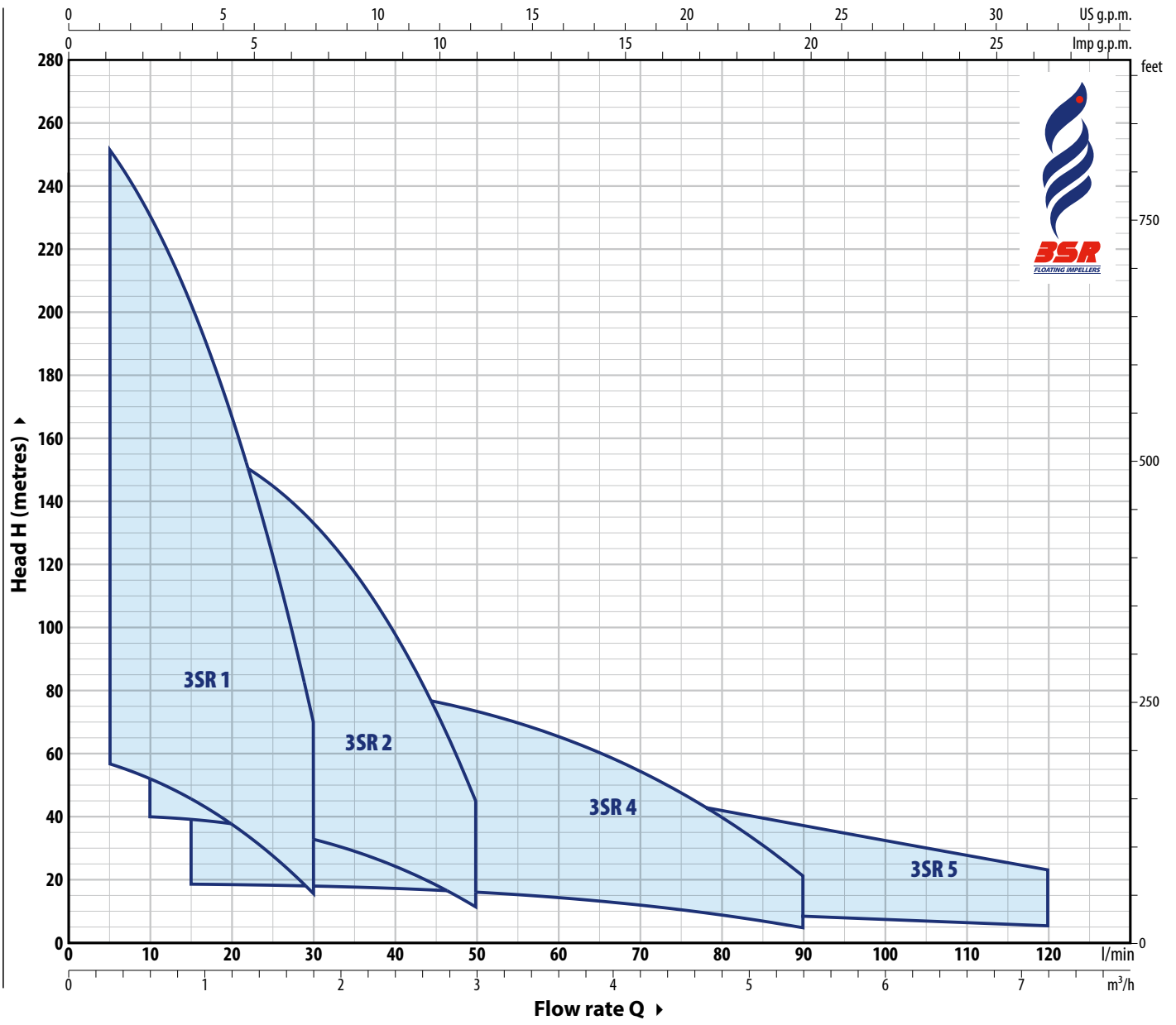

PATENTS:

- Patent No. EP3123031, EP2419642



3SR 3" submersible pumps

CURVES AND PERFORMANCE DATA

50 Hz

3SR 1

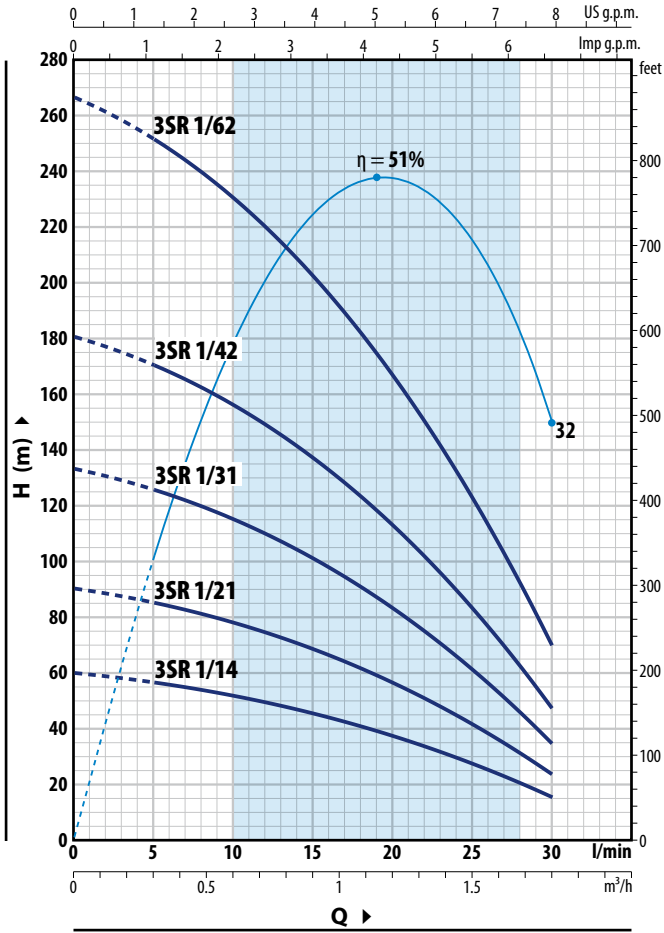

3SR 2

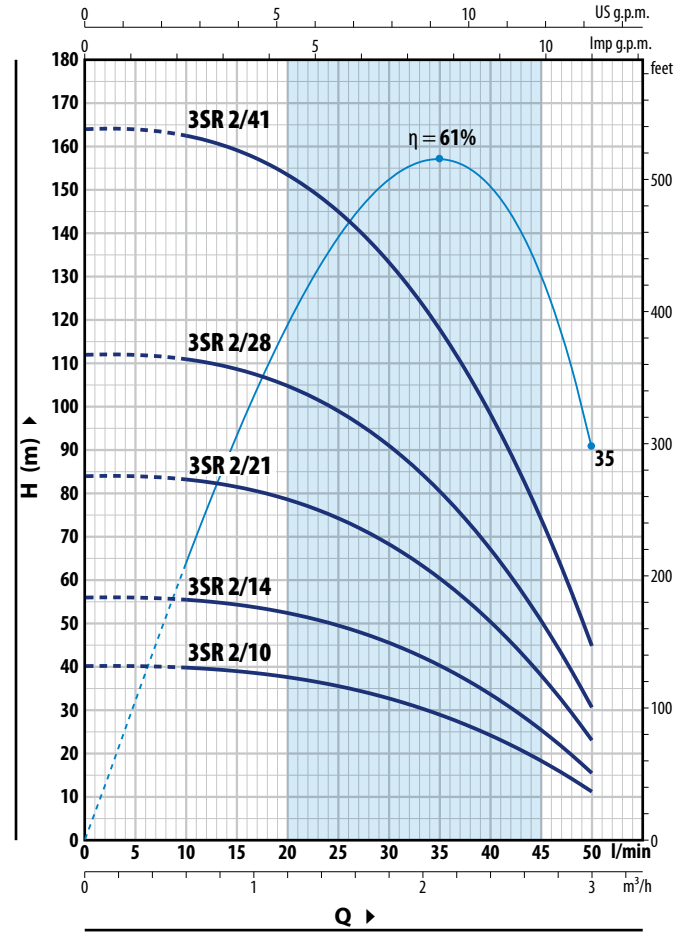

3SR 1

TYPE		POWER (P ₂)		Q	H metres						
Single-phase	Three-phase	kW	HP		m ³ /h	0	0.3	0.6	0.9	1.2	1.5
3SRm 1/14	3SR 1/14	0.25	0.33	0	0	5	10	15	20	25	30
3SRm 1/21	3SR 1/21	0.37	0.50	60	57	52	45.5	37.5	28	16	
3SRm 1/31	3SR 1/31	0.55	0.75	90	85	78	68.5	56.5	41.5	24	
3SRm 1/42	3SR 1/42	0.75	1	133	126	115	101	83	61.5	35	
3SRm 1/62	3SR 1/62	1.1	1.5	181	170	156	137	113	83	47.5	
				267	252	230	203	167	123	70	

3SR 2

TYPE		POWER (P ₂)		Q	H metres								
Single-phase	Three-phase	kW	HP		m ³ /h	0	0.6	0.9	1.2	1.5	1.8	2.1	2.4
3SRm 2/10	3SR 2/10	0.25	0.33	0	0	10	15	20	25	30	35	40	50
3SRm 2/14	3SR 2/14	0.37	0.50	40	39.5	39	37.5	35.5	32.5	28.5	24	11	
3SRm 2/21	3SR 2/21	0.55	0.75	56	55.5	54.5	52.5	49.5	45.5	40	33.5	15.5	
3SRm 2/28	3SR 2/28	0.75	1	84	83	81	79	74	68	60.5	50.5	23	
3SRm 2/41	3SR 2/41	1.1	1.5	112	111	109	105	99	91	80	67	30.5	
				164	162	159	153	145	133	118	98	45	

Q = Flow rate H = Total manometric head

Performance curves comply with EN ISO 9906 Grade 3B tolerance limits.

CURVES AND PERFORMANCE DATA

50 Hz

3SR 4

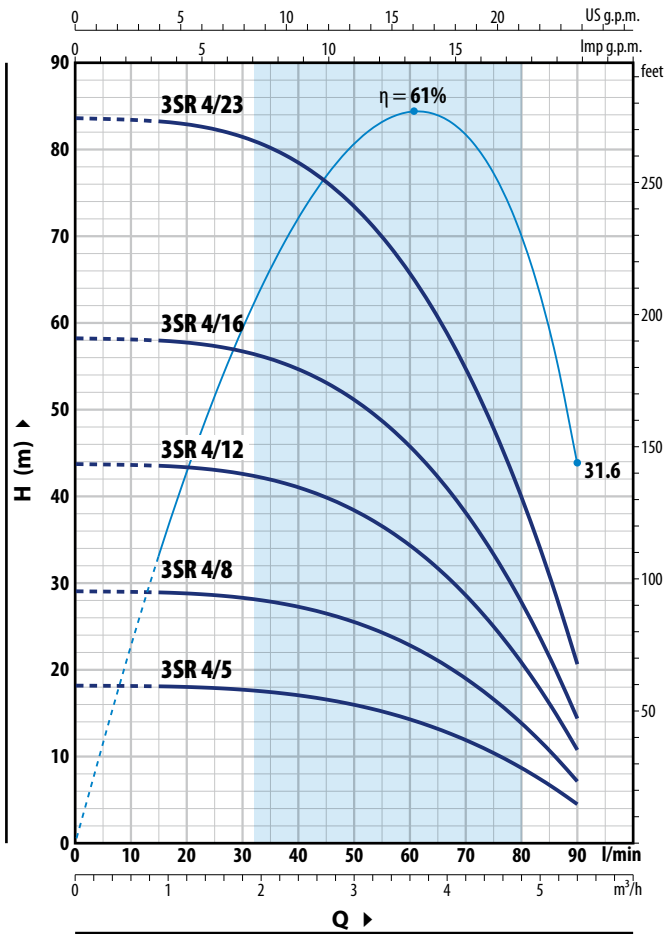

3SR 5

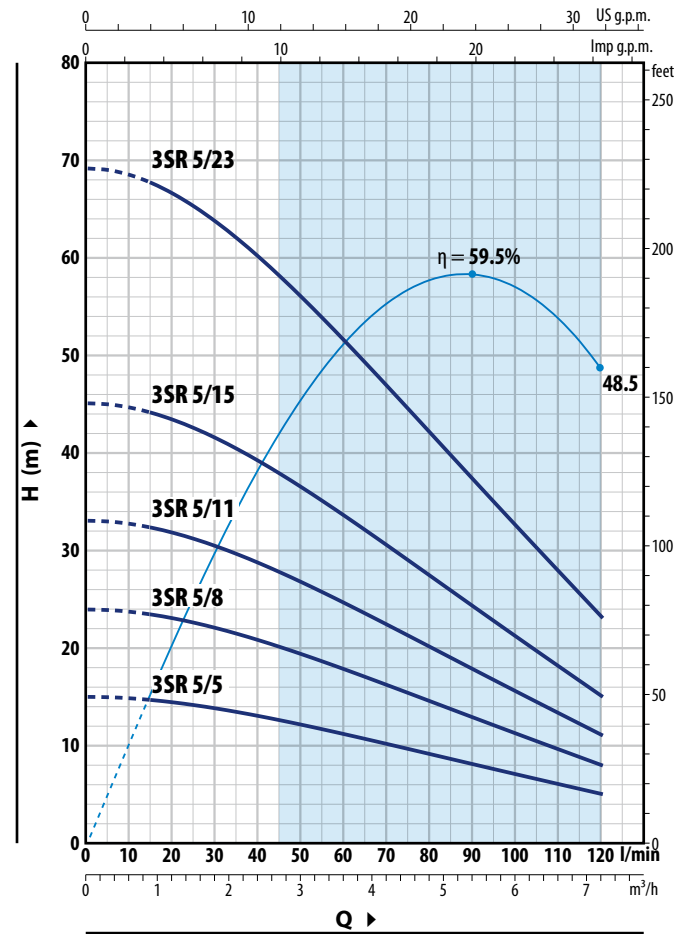

3SR 4

TYPE		POWER (P ₂)		Q	Flow rate									
Single-phase	Three-phase	kW	HP		m ³ /h	0	0.9	1.2	1.8	2.4	3	3.6	4.2	4.8
3SRm 4/5	3SR 4/5	0.25	0.33	H metres	0	15	20	30	40	50	60	70	80	90
3SRm 4/8	3SR 4/8	0.37	0.50		18	18	18	17.8	17.1	16	14.3	12	8.7	4.5
3SRm 4/12	3SR 4/12	0.55	0.75		29	29	29	28.5	27.5	25.6	23	19	14	7
3SRm 4/16	3SR 4/16	0.75	1		43.5	43.5	43.5	42.5	41	38.5	34.5	28.5	21	11
3SRm 4/23	3SR 4/23	1.1	1.5		58.5	58	58	57	54.5	51	46	38	28	14.5
					84	83	83	82	79	74	66	55	40	20.5

※ 3SR5

TYPE		POWER (P ₂)		Q	Flow rate									
Single-phase	Three-phase	kW	HP		m ³ /h	0	0.9	1.8	2.4	3	3.6	4.2	4.8	6
3SRm 5/5	3SR 5/5	0.25	0.33	H metres	0	15	30	40	50	60	70	80	100	120
3SRm 5/8	3SR 5/8	0.37	0.5		15	14.5	13.8	13	12.1	11.2	10.1	9.1	7	5
3SRm 5/11	3SR 5/11	0.55	0.75		24	23.5	22.1	20.8	19.4	17.8	16.2	14.6	11.3	8
3SRm 5/15	3SR 5/15	0.75	1		33	32.5	30.5	28.5	26.7	24.5	22.3	20	15.5	11
3SRm 5/23	3SR 5/23	1.1	1.5		45	44	41.5	39	36.5	33.5	30.5	27.5	21.1	15
					69	67.5	63.5	60	56	51.5	46.5	42	32.5	23

Q = Flow rate H = Total manometric head

Performance curves comply with EN ISO 9906 Grade 3B tolerance limits.

MATERIALS AND COMPONENTS

1 Delivery port	Micro-cast AISI 304 stainless steel with thread according to ISO 228/1
2 Check valve	Stainless steel AISI 304
3 Motor bracket	AISI 304 micro-cast stainless steel, sized to NEMA standards
4 Impellers	Delrin® for 3SR 1-2-4 Noryl™ for 3SR 5
5 Diffusers	Noryl™ - AISI 304 stainless steel
6 Diffuser cover	Noryl™ - AISI 304 stainless steel for 3SR 1-2-4 Noryl™ for 3SR 5
7 Pump shaft	Stainless steel AISI 304
8 Pump bearings	Made of AISI 316L stainless steel coated with chromium oxide, for greater durability even in the presence of sand.
9 Tow coupling	Stainless steel AISI 316L
10 Filter	Stainless steel AISI 304
11 Cable sheath	Stainless steel AISI 304
12 Motor 3"	Rewindable oil-submerged motor

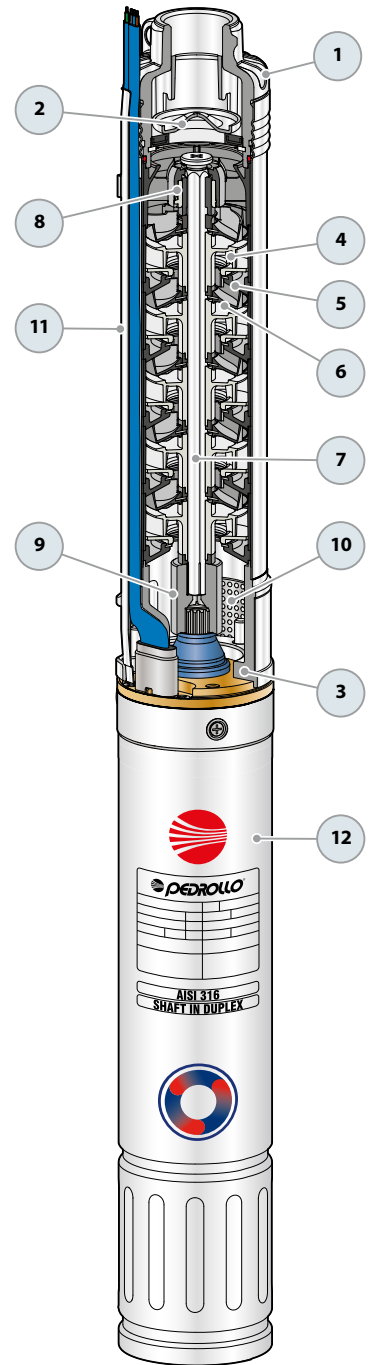

ABSORPTION

Single-phase versions - 230 V

TYPE	Power nominal P ₂		Axial Load N	Capacitor (VL=450V) μF	ABSORPTION
	kW	HP			
230 V / 50 Hz					
3SRm 1/14	0.25	0.33	800	12.5	3.2 A
3SRm 1/21	0.37	0.50		12.5	3.4 A
3SRm 1/31	0.55	0.75		16	4.5 A
3SRm 1/42	0.75	1		20	6.0 A
3SRm 1/62	1.1	1.5		30	8.0 A
3SRm 2/10	0.25	0.33		800	12.5
3SRm 2/14	0.37	0.50	12.5		3.4 A
3SRm 2/21	0.55	0.75	16		4.5 A
3SRm 2/28	0.75	1	20		6.0 A
3SRm 2/41	1.1	1.5	30		8.0 A
3SRm 4/5	0.25	0.33	800		12.5
3SRm 4/8	0.37	0.50		12.5	3.4 A
3SRm 4/12	0.55	0.75		16	4.5 A
3SRm 4/16	0.75	1		20	6.0 A
3SRm 4/23	1.1	1.5		30	8.0 A
3SRm 5/5	0.25	0.33		800	12.5
3SRm 5/8	0.37	0.5	12.5		3.4 A
3SRm 5/11	0.55	0.75	16		4.5 A
3SRm 5/15	0.75	1	20		6.0 A
3SRm 5/23	1.1	1.5	30		8.0 A

Three-phase versions - 400 V

TYPE	Power nominal P ₂		Axial Load N	ABSORPTION
	kW	HP		
400 V / 50 Hz				
3SR 1/14	0.25	0.33	800	1.4 A
3SR 1/21	0.37	0.50		1.5 A
3SR 1/31	0.55	0.75		1.9 A
3SR 1/42	0.75	1		2.6 A
3SR 1/62	1.1	1.5		3.5 A
3SR 2/10	0.25	0.33		800
3SR 2/14	0.37	0.50	1.5 A	
3SR 2/21	0.55	0.75	1.9 A	
3SR 2/28	0.75	1	2.6 A	
3SR 2/41	1.1	1.5	3.5 A	
3SR 4/5	0.25	0.33	800	
3SR 4/8	0.37	0.50		1.5 A
3SR 4/12	0.55	0.75		1.9 A
3SR 4/16	0.75	1		2.6 A
3SR 4/23	1.1	1.5		3.5 A
3SR 5/5	0.25	0.33		800
3SR 5/8	0.37	0.5	1.5 A	
3SR 5/11	0.55	0.75	1.9 A	
3SR 5/15	0.75	1	2.6 A	
3SR 5/23	1.1	1.5	3.5 A	

DIMENSIONS AND WEIGHT

TYPE	PORT DN	Ø	DIMENSIONS mm			kg
			h1	h2	h3	
Single-ph.						
3SRm 1/14	1"	76	415	388	803	9.9
3SRm 1/21			547	388	935	10.4
3SRm 1/31			736	408	1144	12.0
3SRm 1/42			973	448	1421	14.2
3SRm 1/62			1380	488	1868	17.6
3SRm 2/10			1"	76	377	388
3SRm 2/14	467	388			855	9.9
3SRm 2/21	625	408			1033	11.2
3SRm 2/28	813	448			1261	13.1
3SRm 2/41	1136	488			1624	15.8
3SRm 4/5	1"	76			311	388
3SRm 4/8			407	388	795	9.4
3SRm 4/12			534	408	942	10.5
3SRm 4/16			662	448	1110	12.2
3SRm 4/23			915	488	1403	14.5
3SRm 5/5			1"	76	399	388
3SRm 5/8	550	388			938	10.5
3SRm 5/11	700	408			1108	11.9
3SRm 5/15	901	448			1349	14.1
3SRm 5/23	1303	488			1791	17.3
Three-ph.						
3SR 1/14	1"	76	415	368	783	9.0
3SR 1/21			547	368	915	9.5
3SR 1/31			736	388	1124	11.3
3SR 1/42			973	408	1381	13.3
3SR 1/62			1380	448	1828	16.7
3SR 2/10			1"	76	377	368
3SR 2/14	467	368			835	9.0
3SR 2/21	625	388			1013	10.6
3SR 2/28	813	408			1221	12.2
3SR 2/41	1136	448			1584	15.0
3SR 4/5	1"	76			311	368
3SR 4/8			407	368	775	8.5
3SR 4/12			534	388	922	9.8
3SR 4/16			662	408	1070	11.3
3SR 4/23			915	448	1363	13.6
3SR 5/5			1"	76	399	368
3SR 5/8	550	368			918	10.0
3SR 5/11	700	388			1088	11.4
3SR 5/15	901	408			1309	13.1
3SR 5/23	1303	448			1751	16.2

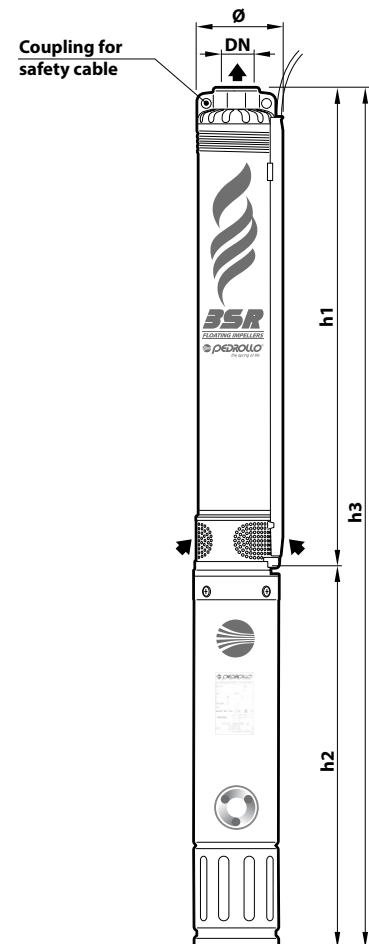

4SR 4" submersible pumps



※ The new 4SR-S series floating impeller pumps, with their advanced hydraulic design and patented innovations, deliver outstanding performance and efficiency. They are exceptionally resistant to sand-related wear, offering a durability 10 times higher than other global market pumps!

※ The new 4SR-S pumps feature a patented inductor that improves priming capabilities in wells with air/water mix or water containing gasses.

PERFORMANCE RANGE

- Flow rate up to **350 l/min** (21 m³/h)
- Head up to **576 m**

INSTALLATION AND USE

They are recommended for pumping clean water. Due to their high efficiency and reliability, they are suitable for **domestic, civil and industrial** applications, for water distribution coupled with autoclaves, for irrigation, for washing systems, for pressure boosting, etc.

※ KEY FEATURES

Low energy consumption and remarkable durability, even in the presence of sand (up to **200 g/m³**), thanks to an innovative patented hydraulics system..

APPLICATION LIMITS

- Liquid temperature up to **+35 °C**
- Maximum sand content:
 - **200 g/m³** for 4SR-S
 - **150 g/m³** for 4SR-N
- Maximum operating depth below water level:
 - **200 m** with 4PD motors
 - **300 m** with 4PS motors

- Operation:
 - in vertical position
 - horizontally with the following limits:
 - 4SR-S** - 1 / 1.5 / 2 / 4 up to **23 stages**
 - 4SR-S** 6 / 8 up to **17 stages**
 - 4SR-N** 10 / 12 / 15 up to **13 stages**
- Starts per hour: **20** at regular intervals
- Minimum motor cooling flow **8 cm/s**
- Continuous running duty **S1**

INCLUDES

ELECTRIC MOTOR

- ※ Three-phase 400 V - 50 Hz
- ※ Single-phase 230 V - 50 Hz
- ※ **Capacitor included in packaging**
- ※ Power cable:
 - **2 m** for power ratings from 0.75 to 2.2 kW
 - **3.6 m** for power ratings from 3 to 7.5 kW.

AVAILABLE UPON REQUEST

- ※ Different voltage requirements 60 Hz frequency
- ※ Cooling jacket kit

PATENTS:

- European Patent No. EP3123031
- European Patent No. EP2419642 for 4SR-S
- Patent No. 10202100003057 for 4SR-S
- **4SR-S**® is a registered trademark No. 018702382
- **SABBIA**® is registered trademark no. 5456231



CURVES AND PERFORMANCE DATA

50 Hz

4SR 1-S

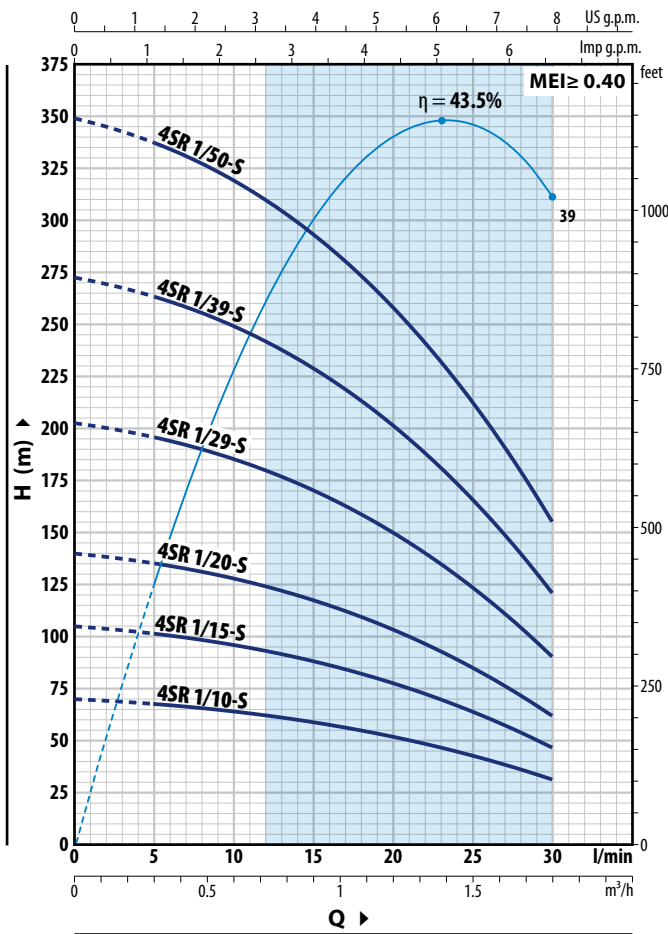

4SR 1.5-S

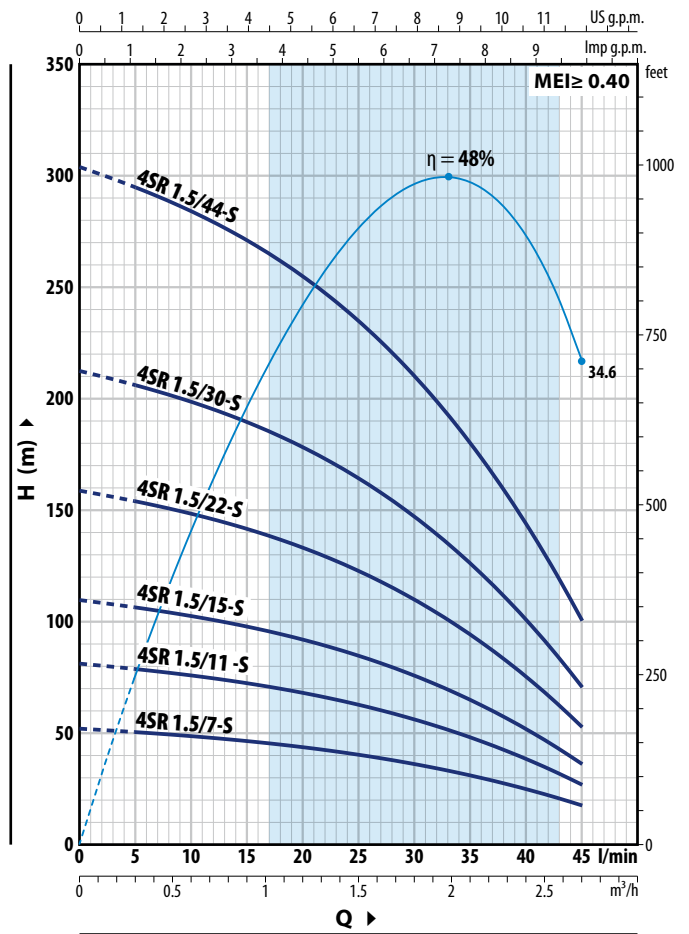

4SR 1-S

TYPE		POWER (P ₂)		Q	H metres							
Single-phase	Three-phase	kW	HP		m ³ /h	0	0.3	0.6	0.9	1.2	1.5	1.8
				l/min	0	5	10	15	20	25	30	
4SRm 1/10 - S	4SR 1/10 - S	0.37	0.50	H metres	70	67.5	64	58.5	51.5	42.5	31	
4SRm 1/15 - S	4SR 1/15 - S	0.55	0.75		105	101	96	88	78	64	46.5	
4SRm 1/20 - S	4SR 1/20 - S	0.75	1		140	135	128	117	103	85	62	
4SRm 1/29 - S	4SR 1/29 - S	1.1	1.5		203	196	185	170	150	123	90	
4SRm 1/39 - S	4SR 1/39 - S	1.5	2		273	264	249	229	202	166	121	
4SRm 1/50 - S	4SR 1/50 - S	2.2	3		350	338	320	294	258	213	155	

4SR 1.5-S

TYPE		POWER (P ₂)		Q	H metres										
Single-phase	Three-phase	kW	HP		m ³ /h	0	0.3	0.6	0.9	1.2	1.5	1.8	2.1	2.4	2.7
				l/min	0	5	10	15	20	25	30	35	40	45	
4SRm 1.5/7 - S	4SR 1.5/7 - S	0.37	0.50	H metres	51.5	50	48.5	46	43.5	40	36	30.5	24.5	17	
4SRm 1.5/11 - S	4SR 1.5/11 - S	0.55	0.75		81	78	75	72	67.5	62.5	55.5	48	38	26.5	
4SRm 1.5/15 - S	4SR 1.5/15 - S	0.75	1		109	106	102	97	92	84	76	64.5	51.5	36	
4SRm 1.5/22 - S	4SR 1.5/22 - S	1.1	1.5		158	154	148	141	133	122	109	94	75	52.5	
4SRm 1.5/30 - S	4SR 1.5/30 - S	1.5	2		213	206	199	190	178	164	147	126	100	70	
4SRm 1.5/44 - S	4SR 1.5/44 - S	2.2	3		304	295	284	271	255	235	210	180	144	100	

Q = Flow rate H = Total manometric head

Performance curves comply with EN ISO 9906 Grade 3B tolerance limits.

4SR-S 4" submersible pumps

CURVES AND PERFORMANCE DATA

50 Hz

4SR 2-S

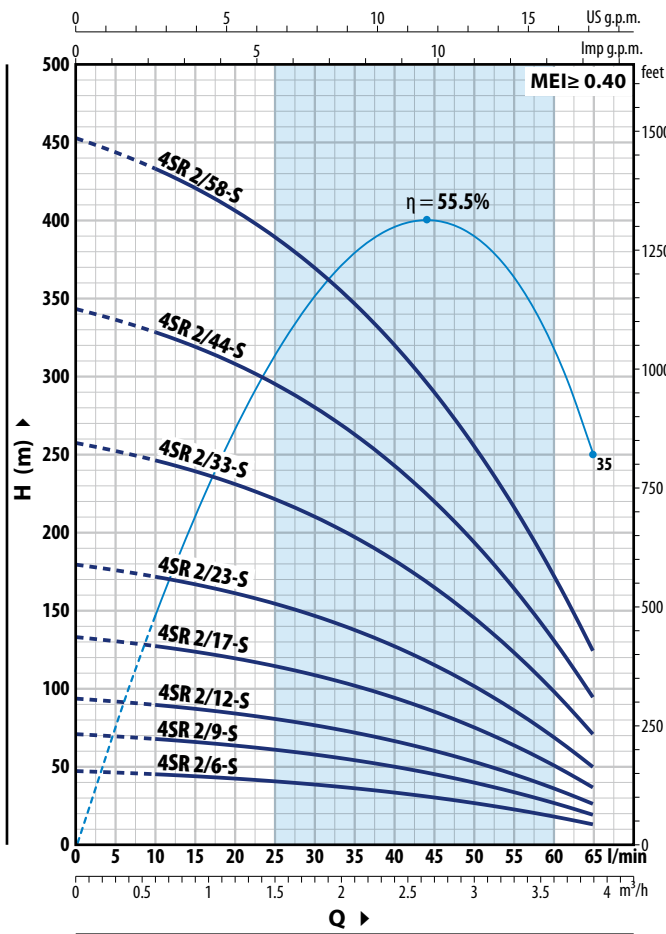

4SR 4-S

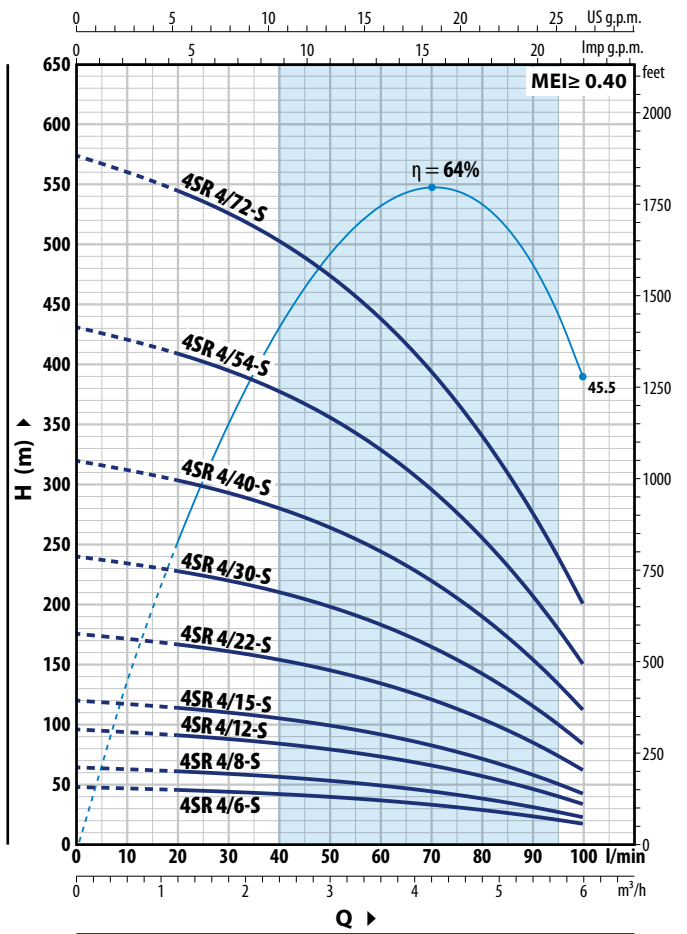

4SR 2-S

TYPE		POWER (P ₂)		Q	H metres								
Single-phase	Three-phase	kW	HP		m ³ /h	0	0.6	1.2	1.8	2.4	3.0	3.6	3.9
				l/min	0	10	20	30	40	50	60	65	
4SRm 2/6 - S	4SR 2/6 - S	0.37	0.50		47	45	42	38	33	26.4	18	13	
4SRm 2/9 - S	4SR 2/9 - S	0.55	0.75		70	67	63	57.5	49.5	39.5	26.8	19.5	
4SRm 2/12 - S	4SR 2/12 - S	0.75	1		94	90	84	76	66	53	36	25.5	
4SRm 2/17 - S	4SR 2/17 - S	1.1	1.5		133	127	119	108	94	75	50.5	36.5	
4SRm 2/23 - S	4SR 2/23 - S	1.5	2		179	172	161	146	127	101	68.5	49	
4SRm 2/33 - S	4SR 2/33 - S	2.2	3		257	246	231	210	182	145	98	71	
-	4SR 2/44 - S	3	4		343	328	308	280	243	194	131	94	
-	4SR 2/58 - S	4	5.5		452	433	406	369	320	256	173	124	

4SR 4-S

TYPE		POWER (P ₂)		Q	H metres									
Single-phase	Three-phase	kW	HP		m ³ /h	0	1.2	1.8	2.4	3.0	3.6	4.2	4.8	5.4
				l/min	0	20	30	40	50	60	70	80	90	100
4SRm 4/6 - S	4SR 4/6 - S	0.55	0.75		48	45.5	44	42	39.5	36.5	33	28.5	23.2	17
4SRm 4/8 - S	4SR 4/8 - S	0.75	1		64	60.5	58.5	56	53	49	44	38	31	22.5
4SRm 4/12 - S	4SR 4/12 - S	1.1	1.5		96	91	88	84	79	73	66	57	46.5	33.5
4SRm 4/15 - S	4SR 4/15 - S	1.5	2		120	114	110	105	99	92	83	71	58	42
4SRm 4/22 - S	4SR 4/22 - S	2.2	3		176	167	161	154	145	134	121	105	85	61.5
-	4SR 4/30 - S	3	4		240	228	220	210	198	183	165	143	116	84
-	4SR 4/40 - S	4	5.5		320	304	293	280	264	244	220	190	154	112
-	4SR 4/54 - S	5.5	7.5		432	410	396	379	357	330	297	257	209	151
-	4SR 4/72 - S	7.5	10		576	547	528	505	476	440	396	342	278	202

Q = Flow rate H = Total manometric head

Performance curves comply with EN ISO 9906 Grade 3B tolerance limits.

CURVES AND PERFORMANCE DATA

50 Hz

4SR 6-S

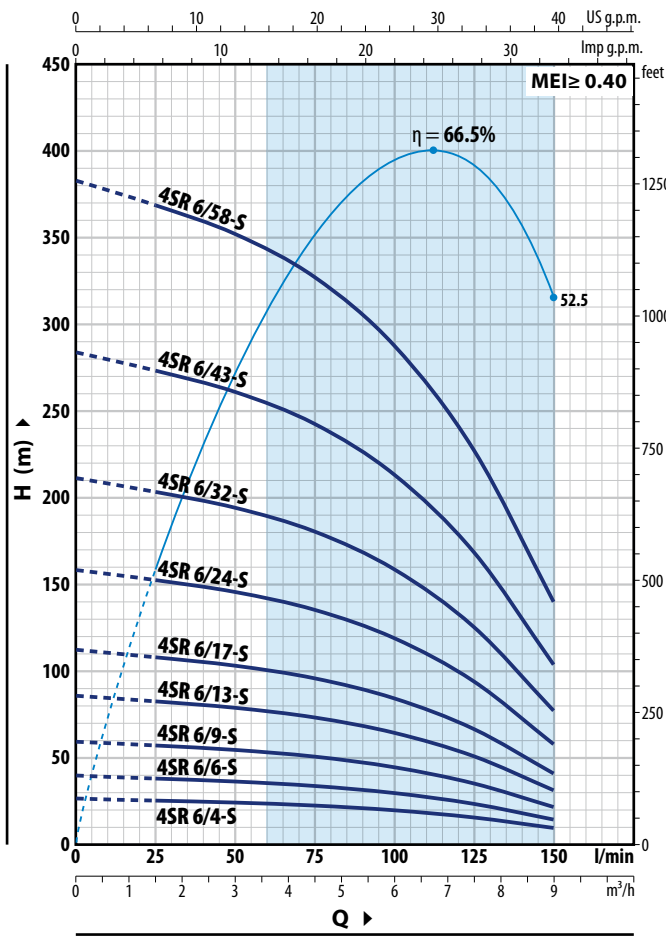

4SR 8-S

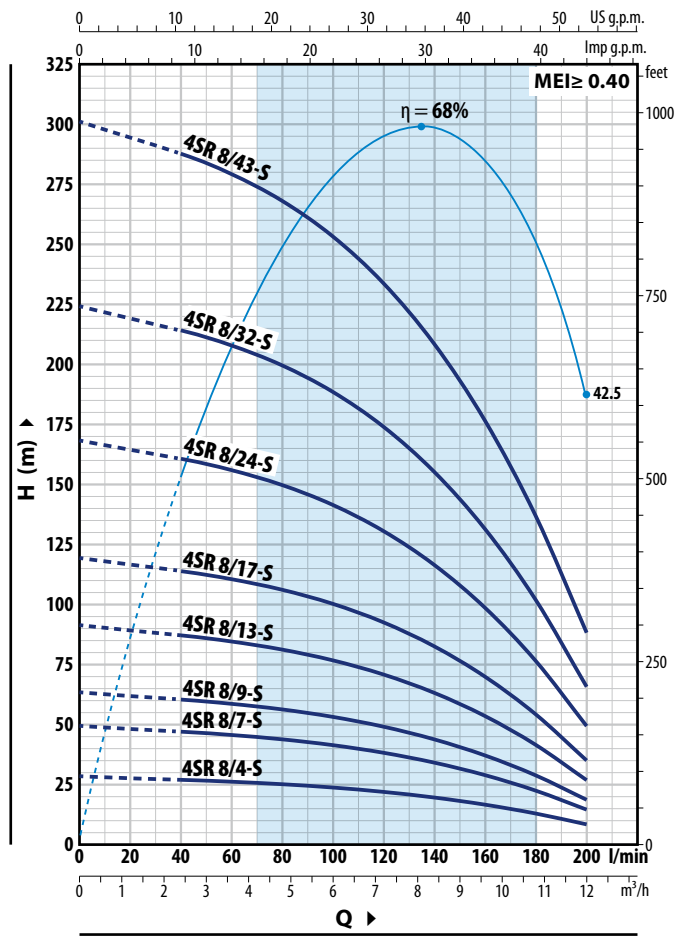

4SR 6-S

TYPE		POWER (P ₂)		Q	m ³ /h							
Single-phase	Three-phase	kW	HP		0	1.5	3.0	4.5	6.0	7.5	9.0	
4SRm 6/4 - S	4SR 6/4 - S	0.55	0.75	H metres	0	25	50	75	100	125	150	
4SRm 6/6 - S	4SR 6/6 - S	0.75	1		26.5	25.5	24.3	22.5	19.8	15.7	9.5	
4SRm 6/9 - S	4SR 6/9 - S	1.1	1.5		39.5	38	36.5	34	29.5	23.5	14.5	
4SRm 6/13 - S	4SR 6/13 - S	1.5	2		59.5	57	54.5	50.5	44.5	35.5	21.5	
4SRm 6/17 - S	4SR 6/17 - S	2.2	3		86	83	79	73	64.5	51	31.5	
-	4SR 6/24 - S	3	4		112	108	103	96	84	66.5	41	
-	4SR 6/32 - S	4	5.5		158	152	146	135	119	94	58	
-	4SR 6/43 - S	5.5	7.5		211	203	194	180	159	125	77	
-	4SR 6/58 - S	7.5	10		284	273	261	242	213	168	104	
-					383	368	352	327	287	227	140	

4SR 8-S

TYPE		POWER (P ₂)		Q	m ³ /h											
Single-phase	Three-phase	kW	HP		0	2.4	3.6	4.8	6.0	7.2	8.4	9.6	10.8	12.0		
4SRm 8/4 - S	4SR 8/4 - S	0.75	1	H metres	0	40	60	80	100	120	140	160	180	200		
4SRm 8/7 - S	4SR 8/7 - S	1.1	1.5		28	27	26	25	23.6	21.8	19.4	16.4	12.7	8		
4SRm 8/9 - S	4SR 8/9 - S	1.5	2		49	47	45.5	43.5	41.5	38	34	28.5	22.3	14.5		
4SRm 8/13 - S	4SR 8/13 - S	2.2	3		63	60.5	58.5	56	53	49	43.5	37	28.5	18.5		
-	4SR 8/17 - S	3	4		91	87	85	81	77	71	63	53.5	41.5	26.5		
-	4SR 8/24 - S	4	5.5		119	114	111	106	100	92	82	70	54	35		
-	4SR 8/32 - S	5.5	7.5		168	161	156	150	141	131	116	99	76	49		
-	4SR 8/43 - S	7.5	10		224	214	208	200	189	174	155	131	102	65.5		
-					301	288	280	268	253	234	209	177	137	88		

Q = Flow rate H = Total manometric head

Performance curves comply with EN ISO 9906 Grade 3B tolerance limits.

4SR-N 4" submersible pumps

CURVES AND PERFORMANCE DATA

50 Hz

4SR 10-N

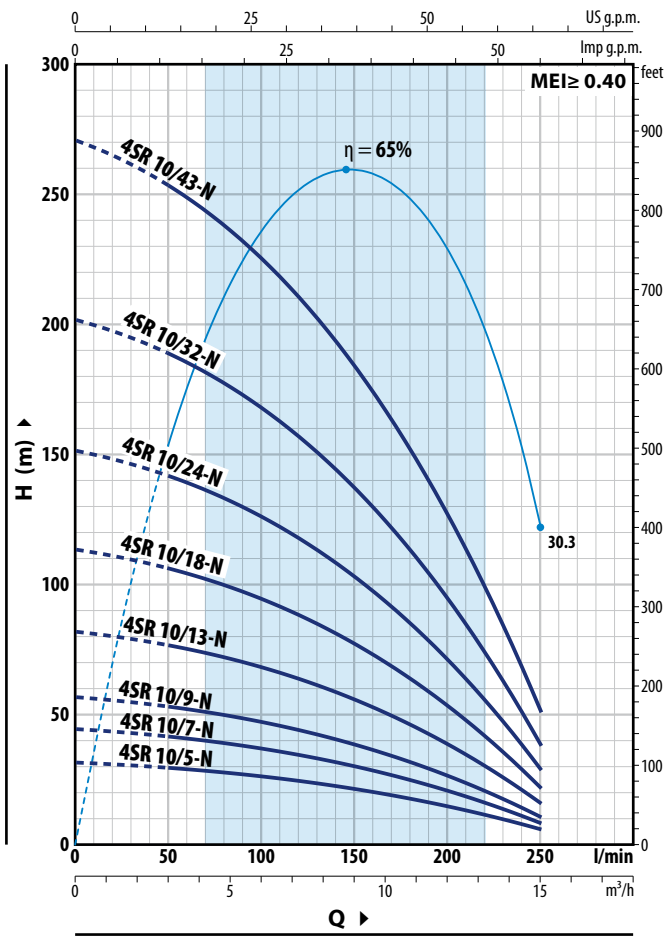

4SR 12-N

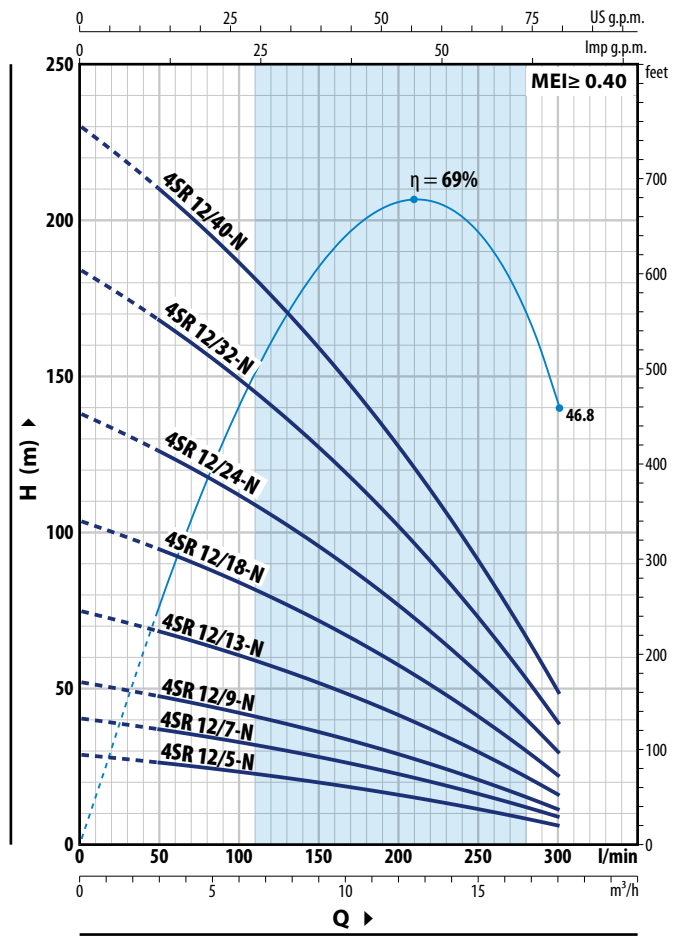

4SR 10-N

TYPE		POWER (P ₂)		Q	H metres								
Single-phase	Three-phase	kW	HP		m³/h	0	3.0	6.0	7.5	9.0	10.5	12.0	13.5
				l/min	0	50	100	125	150	175	200	225	250
4SRm 10/5 - N	4SR 10/5 - N	0.75	1	H metres	31.5	29.5	26.2	24	21.4	18.3	14.7	10.6	6
4SRm 10/7 - N	4SR 10/7 - N	1.1	1.5		44	41.5	36.5	33.5	30	25.6	20.6	14.8	8.5
4SRm 10/9 - N	4SR 10/9 - N	1.5	2		56.5	53	47	43	38.5	33	26.5	19.1	10.5
4SRm 10/13 - N	4SR 10/13 - N	2.2	3		82	77	68	62.5	55.5	47.5	38	27.5	15.5
-	4SR 10/18 - N	3	4		113	106	94	86	77	66	53	38	21
-	4SR 10/24 - N	4	5.5		151	141	126	115	103	88	71	51	28.5
-	4SR 10/32 - N	5.5	7.5		202	189	168	154	137	117	94	68	38
-	4SR 10/43 - N	7.5	10		271	254	226	206	184	157	126	91	51

4SR 12-N

TYPE		POWER (P ₂)		Q	H metres						
Single-phase	Three-phase	kW	HP		m³/h	0	3	6	9	12	15
				l/min	0	50	100	150	200	250	300
4SRm 12/5 - N	4SR 12/5 - N	0.75	1	H metres	29	26	23.2	19.8	15.9	11.3	6
4SRm 12/7 - N	4SR 12/7 - N	1.1	1.5		40.5	36.5	32.5	27.5	22.2	15.8	8.5
4SRm 12/9 - N	4SR 12/9 - N	1.5	2		52	47	42	35.5	28.5	20.3	11
4SRm 12/13 - N	4SR 12/13 - N	2.2	3		75	68	60.5	51.5	41	29.5	15.5
-	4SR 12/18 - N	3	4		104	94	84	71	57	40.5	21.5
-	4SR 12/24 - N	4	5.5		138	126	112	95	76	54	29
-	4SR 12/32 - N	5.5	7.5		184	168	149	127	101	72	38.5
-	4SR 12/40 - N	7.5	10		230	210	186	159	127	90	48

Q = Flow rate H = Total manometric head

Performance curves comply with EN ISO 9906 Grade 3B tolerance limits.

CURVES AND PERFORMANCE DATA

50 Hz

4SR 15-N

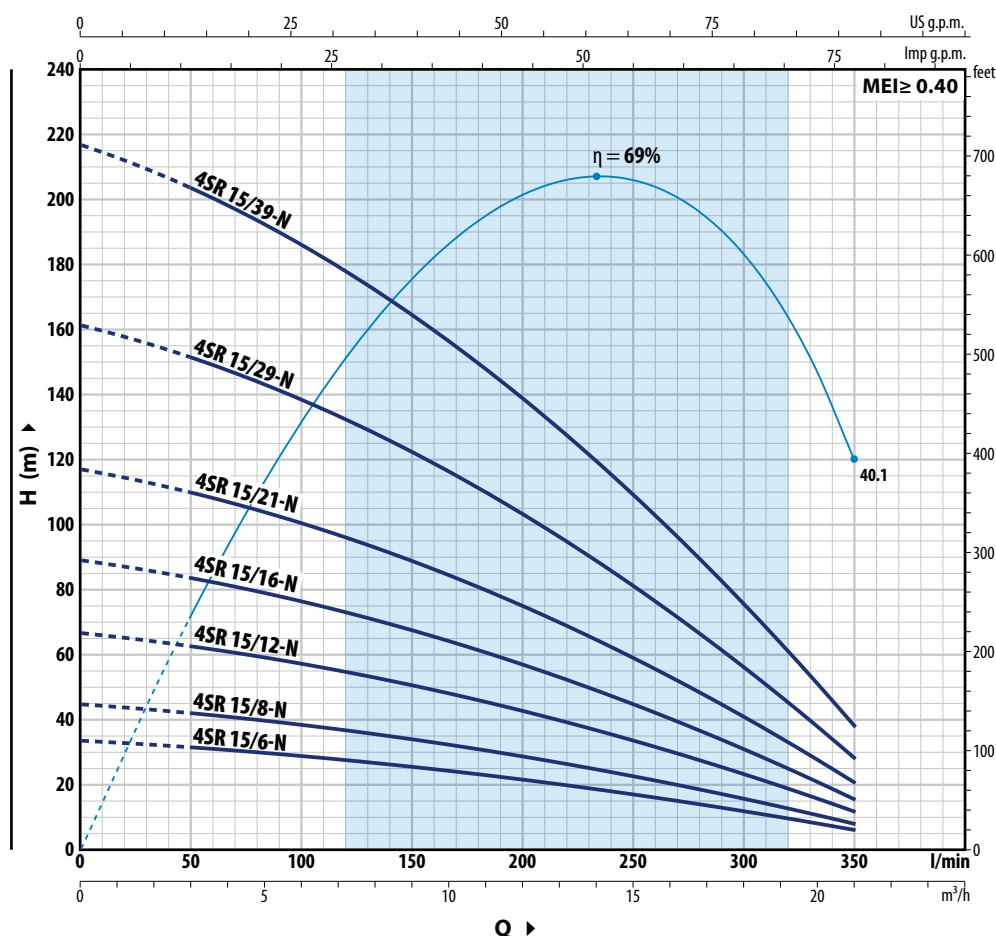

4SR 15-N

TYPE		POWER (P ₂)		Q	H metres								
Single-phase	Three-phase	kW	HP		m ³ /h	0	3.0	6.0	9.0	12	15	18	21.0
				l/min	0	50	100	150	200	250	300	350	
4SRm 15/6 - N	4SR 15/6 - N	1.1	1.5	H metres	33.5	31.5	28.5	25.3	21.3	16.7	11.6	6	
4SRm 15/8 - N	4SR 15/8 - N	1.5	2		44.5	41.5	38	33.5	28.5	22.3	15.4	7.5	
4SRm 15/12 - N	4SR 15/12 - N	2.2	3		66.5	62.5	57	50.5	42.5	33.5	23.1	11.5	
-	4SR 15/16 - N	3	4		89	83	76	67.5	57	44.5	31	15.5	
-	4SR 15/21 - N	4	5.5		117	110	100	88	75	58.5	40.5	20	
-	4SR 15/29 - N	5.5	7.5		161	151	138	122	103	81	56	28	
-	4SR 15/39 - N	7.5	10		217	203	186	164	139	109	75	37.5	

Q = Flow rate H = Total manometric head

Performance curves comply with EN ISO 9906 Grade 3B tolerance limits.

4SR 4" submersible pumps

MATERIALS AND COMPONENTS

1 Delivery port	Micro-cast AISI 304 stainless steel with thread according to ISO 228/1
2 Check valve	Stainless steel AISI 304
3 Motor bracket	Stainless steel AISI 304 , sized to NEMA standards
4 Impeller	Delrin® for 4SR-S, Noryl™ for 4SR-N
5 Diffuser	Noryl™
6 Stadium box	Stainless steel AISI 304
7 Pump shaft	Stainless steel AISI 304
8 Pump bearings	Made of AISI 316L stainless steel coated with chromium oxide to resist sand
9 Tow coupling	Stainless steel
10 Filter	Stainless steel AISI 304
11 Cable sheath	Stainless steel AISI 304
12 Motor 4"	※ 4PD = rewindable oil filled motor ※ 4PS = encapsulated water filled motor

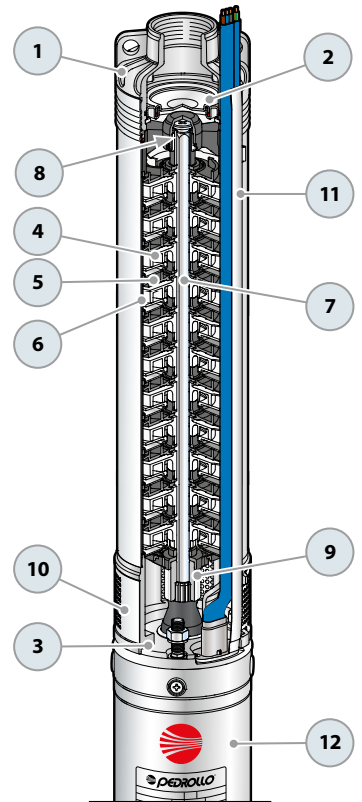

DIMENSIONS AND WEIGHTS (single-phase models)

TYPE	DN	DIMENSIONS mm			kg	TYPE	DN	DIMENSIONS mm			kg
		h1	h2	h3				h1	h2	h3	
Single-phase ※						Single-phase ※					
4SRm 1/10 - S - PD	1 1/4"	362	311	673	10.8	4SRm 1/10 - S - PS	1 1/4"	362	237	599	12.3
4SRm 1/15 - S - PD		488	331	819	13.2	4SRm 1/15 - S - PS		488	257	745	14.4
4SRm 1/20 - S - PD		588	356	944	15.9	4SRm 1/20 - S - PS		588	272	860	16.6
4SRm 1/29 - S - PD		767	396	1163	19.9	4SRm 1/29 - S - PS		767	312	1079	20.6
4SRm 1/39 - S - PD		992	437	1429	24.4	4SRm 1/39 - S - PS		992	352	1344	25
4SRm 1/50 - S - PD		1284	492	1776	31.3	4SRm 1/50 - S - PS		1284	402	1686	30.6
4SRm 1.5/7 - S - PD		303	311	614	10.1	4SRm 1.5/7 - S - PS		303	237	540	10.1
4SRm 1.5/11 - S - PD		382	331	713	11.8	4SRm 1.5/11 - S - PS		382	257	639	12.2
4SRm 1.5/15 - S - PD		488	356	844	14.0	4SRm 1.5/15 - S - PS		488	272	760	14.8
4SRm 1.5/22 - S - PD		627	396	1023	17.8	4SRm 1.5/22 - S - PS		627	312	939	18.4
4SRm 1.5/30 - S - PD		787	437	1224	21.4	4SRm 1.5/30 - S - PS		787	352	1139	22.6
4SRm 1.5/44 - S - PD		1163	492	1655	29.2	4SRm 1.5/44 - S - PS		1163	402	1565	28.8
4SRm 2/6 - S - PD		283	311	594	10.0	4SRm 2/6 - S - PS		283	237	520	10.2
4SRm 2/9 - S - PD		343	331	674	11.4	4SRm 2/9 - S - PS		343	257	600	11.8
4SRm 2/12 - S - PD		402	356	758	13.3	4SRm 2/12 - S - PS		402	272	674	14.0
4SRm 2/17 - S - PD		528	396	924	16.1	4SRm 2/17 - S - PS		528	312	840	17.0
4SRm 2/23 - S - PD		647	437	1084	20.1	4SRm 2/23 - S - PS		647	352	999	20.6
4SRm 2/33 - S - PD		873	492	1365	24.9	4SRm 2/33 - S - PS		873	402	1275	24.8
4SRm 4/6 - S - PD		313	331	644	11.2	4SRm 4/6 - S - PS		313	257	570	11.5
4SRm 4/8 - S - PD		363	356	719	12.9	4SRm 4/8 - S - PS		363	272	635	13.6
4SRm 4/12 - S - PD	462	396	858	15.5	4SRm 4/12 - S - PS	462	312	774	15.3		
4SRm 4/15 - S - PD	563	437	1000	18.4	4SRm 4/15 - S - PS	563	352	915	18.8		
4SRm 4/22 - S - PD	737	492	1229	23.2	4SRm 4/22 - S - PS	737	402	1139	24.0		
4SRm 6/4 - S - PD	2"	289	331	620	11.0	4SRm 6/4 - S - PS	2"	289	257	546	11.1
4SRm 6/6 - S - PD		352	356	708	12.7	4SRm 6/6 - S - PS		352	272	624	13.2
4SRm 6/9 - S - PD		446	396	842	15.2	4SRm 6/9 - S - PS		446	312	758	15.8
4SRm 6/13 - S - PD		598	437	1035	18.4	4SRm 6/13 - S - PS		598	352	950	19.0
4SRm 6/17 - S - PD		723	492	1215	22.7	4SRm 6/17 - S - PS		723	402	1125	22.8
4SRm 8/4 - S - PD		289	356	645	12.1	4SRm 8/4 - S - PS		289	272	561	12.3
4SRm 8/7 - S - PD		382	396	778	15.0	4SRm 8/7 - S - PS		382	312	694	15.4
4SRm 8/9 - S - PD		446	437	883	17.0	4SRm 8/9 - S - PS		446	352	798	17.8
4SRm 8/13 - S - PD		598	492	1090	21.0	4SRm 8/13 - S - PS		598	402	1000	20.2

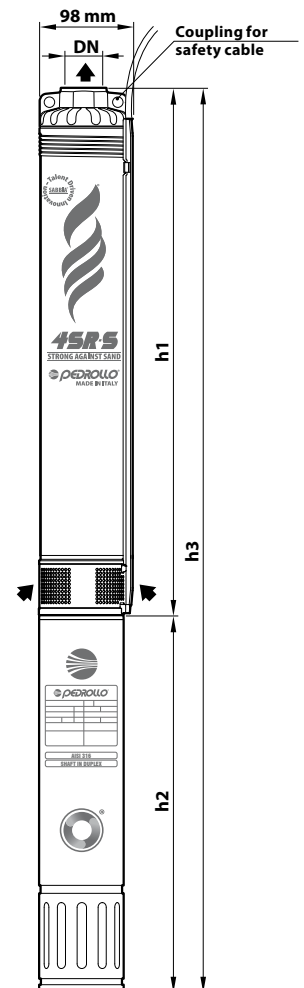

DIMENSIONS AND WEIGHTS (three-phase models)

TYPE	DN	DIMENSIONS mm			kg	TYPE	DN	DIMENSIONS mm			kg
Three-phase ※		h1	h2	h3		Three-phase ※		h1	h2	h3	
4SR 1/10 - S - PD	1 1/4"	362	311	673	10.6	4SR 1/10 - S - PS	1 1/4"	362	237	599	12.2
4SR 1/15 - S - PD		488	331	819	13.5	4SR 1/15 - S - PS		488	237	725	13.9
4SR 1/20 - S - PD		588	356	944	14.2	4SR 1/20 - S - PS		588	257	845	15.6
4SR 1/29 - S - PD		767	371	1138	17.8	4SR 1/29 - S - PS		767	272	1039	18.8
4SR 1/39 - S - PD		992	396	1388	22.8	4SR 1/39 - S - PS		992	297	1289	22.6
4SR 1/50 - S - PD		1284	437	1721	28.1	4SR 1/50 - S - PS		1284	352	1636	29.8
4SR 1.5/7 - S - PD		303	311	614	10.0	4SR 1.5/7 - S - PS		303	237	540	10.1
4SR 1.5/11 - S - PD		382	331	713	11.7	4SR 1.5/11 - S - PS		382	237	619	11.1
4SR 1.5/15 - S - PD		488	356	844	13.8	4SR 1.5/15 - S - PS		488	257	745	13.8
4SR 1.5/22 - S - PD		627	371	998	16.2	4SR 1.5/22 - S - PS		627	272	899	16.4
4SR 1.5/30 - S - PD		787	396	1183	19.3	4SR 1.5/30 - S - PS		787	297	1084	20.5
4SR 1.5/44 - S - PD		1163	437	1600	26.6	4SR 1.5/44 - S - PS		1163	352	1515	28.0
4SR 2/6 - S - PD		283	311	594	9.8	4SR 2/6 - S - PS		283	237	520	10.2
4SR 2/9 - S - PD		343	331	674	11.4	4SR 2/9 - S - PS		343	237	580	10.7
4SR 2/12 - S - PD		402	356	758	13.1	4SR 2/12 - S - PS		402	257	659	13.2
4SR 2/17 - S - PD		528	371	899	15.0	4SR 2/17 - S - PS		528	272	800	15.5
4SR 2/23 - S - PD		647	396	1043	17.7	4SR 2/23 - S - PS		647	297	944	17.8
4SR 2/33 - S - PD		873	437	1310	22.3	4SR 2/33 - S - PS		873	352	1225	24.0
4SR 2/44 - S - PD		1163	450	1613	27.8	4SR 2/44 - S - PS		1163	484	1647	31.6
4SR 2/58 - S - PD		1432	625	2057	34.4	4SR 2/58 - S - PS		1432	574	2006	41.7
4SR 4/6 - S - PD	1 1/2"	313	331	644	11.0	4SR 4/6 - S - PS	1 1/2"	313	237	550	11.2
4SR 4/8 - S - PD		363	356	719	12.4	4SR 4/8 - S - PS		363	257	620	12.6
4SR 4/12 - S - PD		462	371	833	15.5	4SR 4/12 - S - PS		462	272	734	14.2
4SR 4/15 - S - PD		563	396	959	16.3	4SR 4/15 - S - PS		563	297	860	16.2
4SR 4/22 - S - PD		737	437	1174	20.3	4SR 4/22 - S - PS		737	352	1089	20.8
4SR 4/30 - S - PD		963	450	1413	23.7	4SR 4/30 - S - PS		963	484	1447	28.4
4SR 4/40 - S - PD		1284	625	1909	35.0	4SR 4/40 - S - PS		1284	574	1858	40.4
4SR 4/54 - S - PD		1684	725	2409	47.0	4SR 4/54 - S - PS		1684	664	2348	40.0
4SR 4/72 - S - PD		2134	845	2979	54.0	4SR 4/72 - S - PS		2134	764	2898	54.4
4SR 6/4 - S - PD		2"	289	331	620	10.8		4SR 6/4 - S - PS	2"	289	237
4SR 6/6 - S - PD	352		356	708	12.0	4SR 6/6 - S - PS	352	257		609	12.4
4SR 6/9 - S - PD	446		371	817	13.9	4SR 6/9 - S - PS	446	272		718	14.0
4SR 6/13 - S - PD	598		396	994	16.3	4SR 6/13 - S - PS	598	297		895	17.3
4SR 6/17 - S - PD	723		437	1160	20.0	4SR 6/17 - S - PS	723	352		1075	20.4
4SR 6/24 - S - PD	969		450	1419	23.5	4SR 6/24 - S - PS	969	484		1453	27.3
4SR 6/32 - S - PD	1247		625	1872	32.0	4SR 6/32 - S - PS	1247	574		1821	35.2
4SR 6/43 - S - PD	1618		725	2343	45.0	4SR 6/43 - S - PS	1618	664		2282	45.0
4SR 6/58 - S - PD	2161		845	3006	55.0	4SR 6/58 - S - PS	2161	764		2925	55.0
4SR 8/4 - S - PD	289		356	645	11.6	4SR 8/4 - S - PS	289	257		546	11.1
4SR 8/7 - S - PD	382		371	753	13.4	4SR 8/7 - S - PS	382	272		654	14.3
4SR 8/9 - S - PD	446		396	842	15.1	4SR 8/9 - S - PS	446	297		743	15.0
4SR 8/13 - S - PD	598		437	1035	18.2	4SR 8/13 - S - PS	598	352		950	18.8
4SR 8/17 - S - PD	723		450	1173	21.1	4SR 8/17 - S - PS	723	484		1207	25.8
4SR 8/24 - S - PD	969		625	1594	30.0	4SR 8/24 - S - PS	969	574		1543	33.7
4SR 8/32 - S - PD	1247		725	1972	40.6	4SR 8/32 - S - PS	1247	664		1911	39.4
4SR 8/43 - S - PD	1618	845	2463	49.0	4SR 8/43 - S - PS	1618	764	2382	49.0		

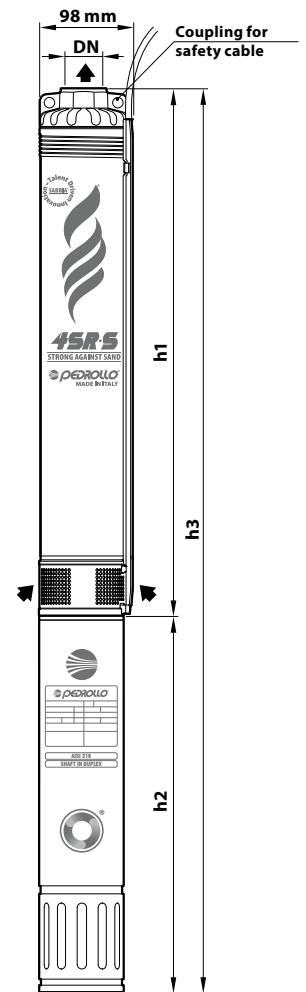

※ 4PD = rewindable in oil filled motor

※ 4PS = encapsulated water filled motor

4SR 4" submersible pumps

DIMENSIONS AND WEIGHT

TYPE	DN	DIMENSIONS mm			kg	TYPE	DN	DIMENSIONS mm			kg
		h1	h2	h3				h1	h2	h3	
Single-phase ※						Single-phase ※					
4SRm 10/5 - N - PD	2"	430	357	787	12.4	4SRm 10/5 - N - PS	2"	430	272	702	13.0
4SRm 10/7 - N - PD		532	397	929	16.7	4SRm 10/7 - N - PS		532	312	844	17.7
4SRm 10/9 - N - PD		633	437	1070	18.9	4SRm 10/9 - N - PS		633	352	985	20.6
4SRm 10/13 - N - PD		837	492	1329	25.6	4SRm 10/13 - N - PS		837	402	1239	24.9
4SRm 12/5 - N - PD		488	357	845	13.0	4SRm 12/5 - N - PS		488	272	760	13.5
4SRm 12/7 - N - PD		613	397	1010	15.5	4SRm 12/7 - N - PS		613	312	925	16.5
4SRm 12/9 - N - PD		738	437	1175	18.5	4SRm 12/9 - N - PS		738	352	1090	20.0
4SRm 12/13 - N - PD		989	492	1481	23.5	4SRm 12/13 - N - PS		989	402	1391	23.0
4SRm 15/6 - N - PD		550	397	947	16.0	4SRm 15/6 - N - PS		550	312	862	16.0
4SRm 15/8 - N - PD		676	437	1113	19.5	4SRm 15/8 - N - PS		676	352	1028	19.5
4SRm 15/12 - N - PD		926	492	1418	22.5	4SRm 15/12 - N - PS		926	402	1328	22.5
Three-phase ※								Three-phase ※			
4SR 10/5 - N - PD	2"	430	357	787	12.4	4SR 10/5 - N - PS	2"	430	257	687	11.8
4SR 10/7 - N - PD		532	372	904	14.2	4SR 10/7 - N - PS		532	272	804	13.9
4SR 10/9 - N - PD		633	397	1030	15.9	4SR 10/9 - N - PS		633	297	930	16.9
4SR 10/13 - N - PD		837	437	1274	19.2	4SR 10/13 - N - PS		837	352	1189	20.9
4SR 10/18 - N - PD		1092	450	1542	23.0	4SR 10/18 - N - PS		1092	484	1576	26.8
4SR 10/24 - N - PD		1398	625	2023	32.4	4SR 10/24 - N - PS		1398	574	1972	37.4
4SR 10/32 - N - PD		1805	725	2530	43.4	4SR 10/32 - N - PS		1805	664	2469	43.8
4SR 10/43 - N - PD		2366	845	3211	52.0	4SR 10/43 - N - PS		2366	764	3130	52.4
4SR 12/5 - N - PD		488	357	845	13.0	4SR 12/5 - N - PS		488	257	745	12.0
4SR 12/7 - N - PD		613	372	985	14.5	4SR 12/7 - N - PS		613	272	885	14.5
4SR 12/9 - N - PD		738	397	1135	17.0	4SR 12/9 - N - PS		738	297	1035	18.0
4SR 12/13 - N - PD		989	437	1426	20.5	4SR 12/13 - N - PS		989	352	1341	22.0
4SR 12/18 - N - PD		1302	450	1752	25.0	4SR 12/18 - N - PS		1302	484	1786	25.6
4SR 12/24 - N - PD		1677	625	2302	34.5	4SR 12/24 - N - PS		1677	574	2251	38.0
4SR 12/32 - N - PD		2178	725	2903	46.1	4SR 12/32 - N - PS		2178	664	2842	46.5
4SR 12/40 - N - PD		2679	845	3524	54.0	4SR 12/40 - N - PS		2679	764	3443	54.0
4SR 15/6 - N - PD		550	372	922	15.0	4SR 15/6 - N - PS		550	272	822	14.0
4SR 15/8 - N - PD		676	397	1073	17.9	4SR 15/8 - N - PS		676	297	973	17.5
4SR 15/12 - N - PD		926	437	1363	22.4	4SR 15/12 - N - PS		926	352	1278	21.5
4SR 15/16 - N - PD		1176	450	1626	25.4	4SR 15/16 - N - PS		1176	484	1660	27.5
4SR 15/21 - N - PD	1489	625	2114	33.0	4SR 15/21 - N - PS	1489	574	2063	36.5		
4SR 15/29 - N - PD	1990	725	2715	48.2	4SR 15/29 - N - PS	1990	664	2654	45.0		
4SR 15/39 - N - PD	2616	845	3461	58.0	4SR 15/39 - N - PS	2616	764	3380	53.5		

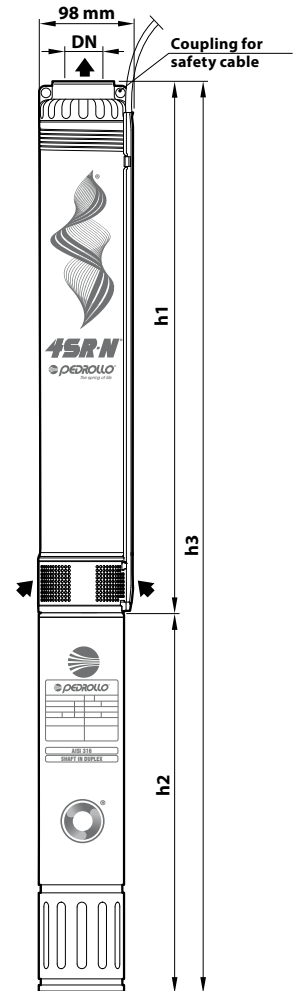

※ 4PD = rewindable oil filled motor

※ 4PS = encapsulated water filled motor

EXAMPLES OF INSTALLATION

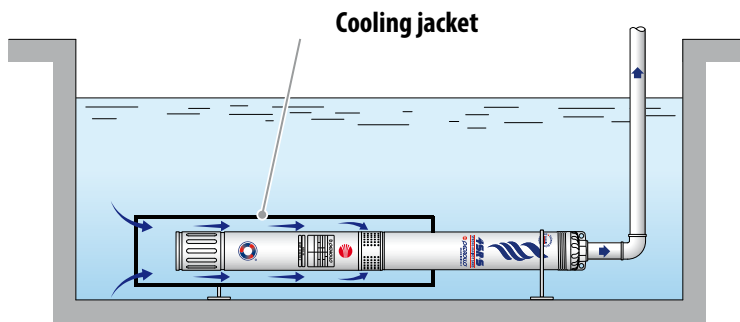

COOLING JACKET

- ✘ When the pump is installed in reservoirs, rivers, or lakes, it requires an external cooling jacket (flow generator) to ensure sufficient water flow across the motor surface, preventing overheating.
- ✘ Recommended for power ratings from 3 kW to 7.5 kW



- ✘ The **4SR** pumps are suitable for wells with a minimum diameter of **4" (100 mm)**.
- ✘ The submersible pump must be lowered into the well through the delivery pipe to a depth that ensures it remains fully submerged, maintaining at least 50 cm or one metre from the bottom of the well, even if liquid levels decrease during operation.
- ✘ It is advisable to secure the submersible pump using a stainless-steel cable connected to appropriate attachments on the delivery port.

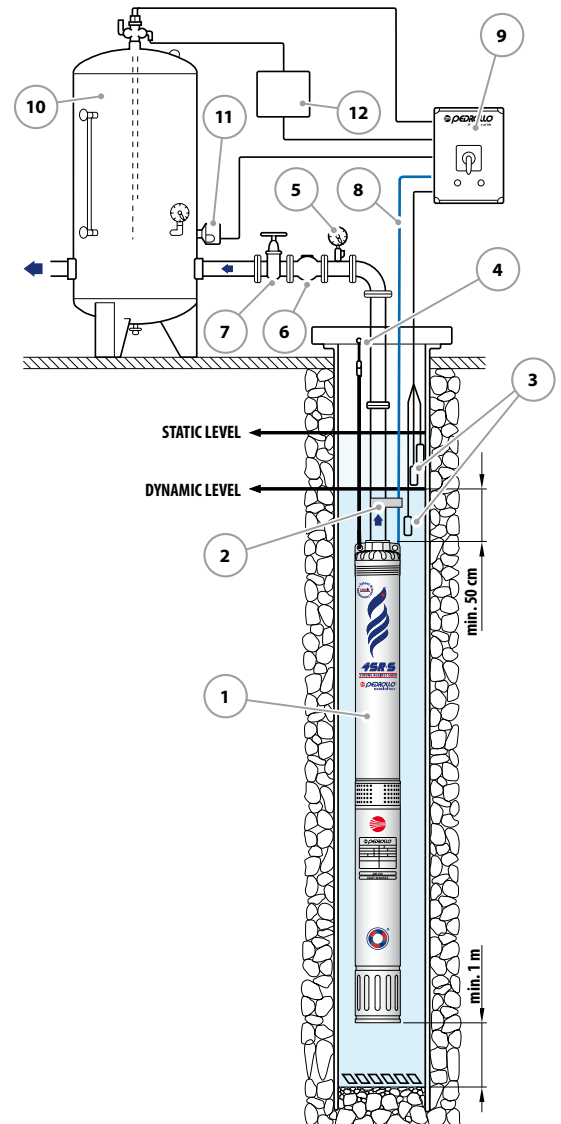

COMPONENTS

- 1) Submersible pump
- 2) Fixing Ties
- 3) Level control probes
- 4) Bracket and anchor cable
- 5) Pressure Gauge
- 6) Check valve
- 7) Flow control gate valve
- 8) Electrical power supply cable
- 9) Power switchboard
- 10) Autoclave tank
- 11) Pressure switch
- 12) Solenoid valve/electric compressor



※ **6SR submersible pumps: designed with special materials to resist sand abrasion for long-lasting performance**

PERFORMANCE RANGE

- Flow rate up to **1000 l/min** (60 m³/h)
- Head up to **390 m**

INSTALLATION AND USE

Designed to transfer clean water with sand content up to **100 g/m³**. Highly efficient and reliable, they are suitable for industrial, civil, and agricultural applications, such as water distribution coupled with pressure tanks, irrigation, pressure boosting, fire-fighting systems, and more.

INCLUDES

- ※ Three-phase electric motor 400 V - 50 Hz
 - The pump can be supplied with motor:
 - **6PD** rewindable and oil filled
 - **6PSR** rewindable and water filled
- ※ **4 m** power cable

APPLICATION LIMITS

- Liquid temperature up to **+35 °C**
- Maximum sand content **100 g/m³**
- Maximum operating depth below water level:
 - **200 m** with 6PD motors
 - **150 m** with 6PSR motors
- Operation:
 - in vertical position
 - horizontally with the following limits: up to **12 stages** or up to **11 kW**
- Starts per hour: **20** at regular intervals
- Minimum cooling flow **8 cm/s**
- Continuous running duty **S1**

AVAILABLE UPON REQUEST

- ※ 6SR-HYD pumps with double cable cover for coupling with 400/690 V Δ/Δ dual voltage motors (star/delta)
- ※ Other voltages
- ※ Cooling jacket kit complete with filter and supinlets

CURVES AND PERFORMANCE DATA

50 Hz

6SR 12

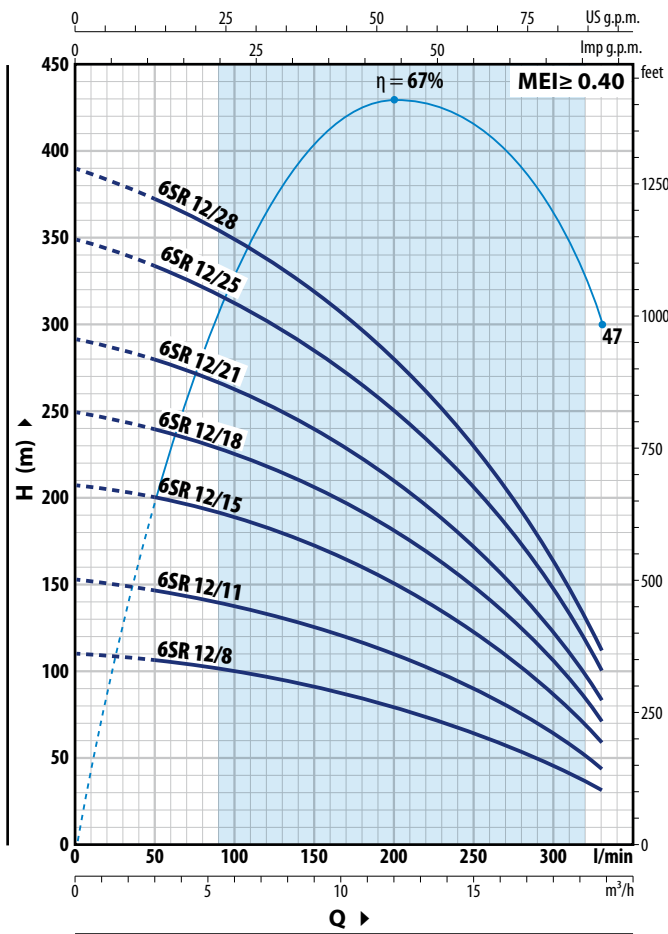

6SR 18

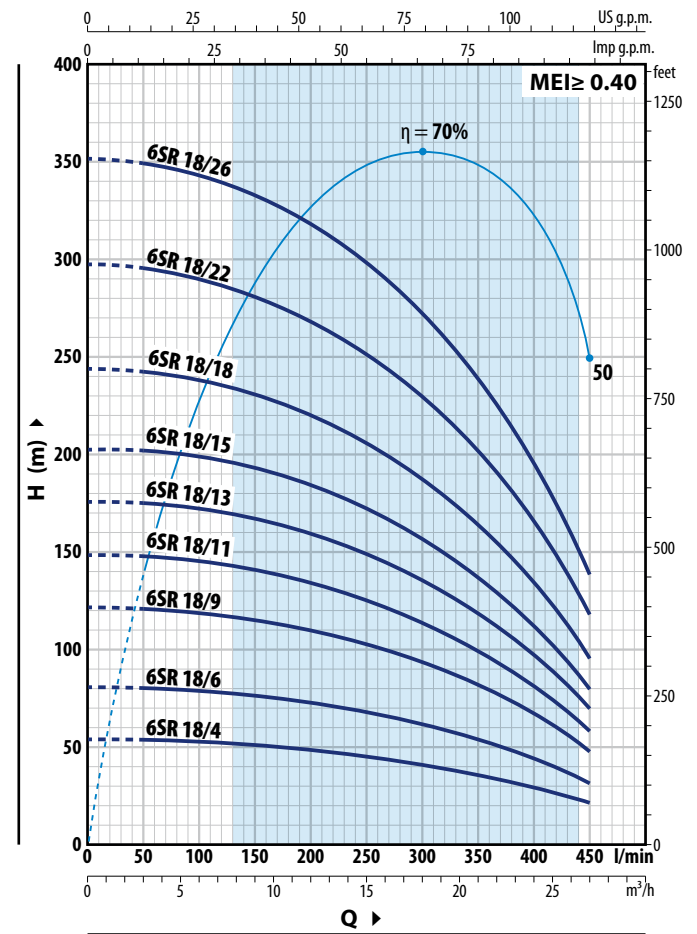

6SR 12

TYPE	POWER (P ₂)		Q	H metres										
	kW	HP		0	3.0	6.0	9.0	12.0	15.0	18.0	19.8			
Three-phase			l/min	0	50	100	150	200	250	300	330			
6SR 12/8	4	5.5		111	106	100	91	80	66	47	32			
6SR 12/11	5.5	7.5		153	146	138	125	110	91	65	44			
6SR 12/15	7.5	10		208	199	189	171	150	124	88	60			
6SR 12/18	9.2	12.5		250	239	225	205	180	149	106	72			
6SR 12/21	11	15		292	279	263	239	210	174	124	84			
6SR 12/25	13	17.5		349	331	313	285	250	206	147	100			
6SR 12/28	15	20		390	371	350	319	280	231	165	112			

6SR 18

TYPE	POWER (P ₂)		Q	H metres												
	kW	HP		0	3	6	9	12	15	18	21	24	27			
Three-phase			l/min	0	50	100	150	200	250	300	350	400	450			
6SR 18/4	4	5.5		54	53.8	53	51	49	46	42	37	30	22			
6SR 18/6	5.5	7.5		81	80.5	79	77	74	69	63	55	45	32			
6SR 18/9	7.5	10		122	121	119	116	111	103	94	83	68	48			
6SR 18/11	9.2	12.5		149	148	145.5	141	135	126	115	101	83	59			
6SR 18/13	11	15		176	175	172	167	160	149	136	120	98	70			
6SR 18/15	13	17.5		203	202	199	193	185	172	157	138	113	80			
6SR 18/18	15	20		244	242	238	231	221	206	188	165	135	96			
6SR 18/22	18.5	25		298	296	291	282	270	252	230	202	165	118			
6SR 18/26	22	30		352	350	344	334	320	298	272	239	195	139			

Q = Flow rate H = Total manometric head

Performance curves comply with EN ISO 9906 Grade 3B tolerance limits.

6SR 6" submersible pumps

CURVES AND PERFORMANCE DATA

50 Hz

6SR 27

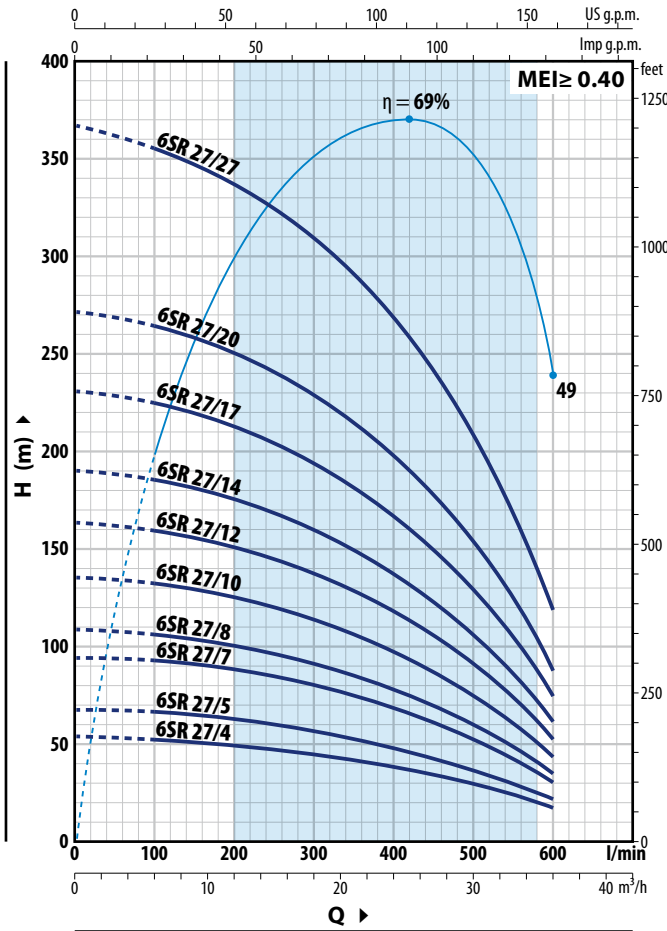

6SR 36

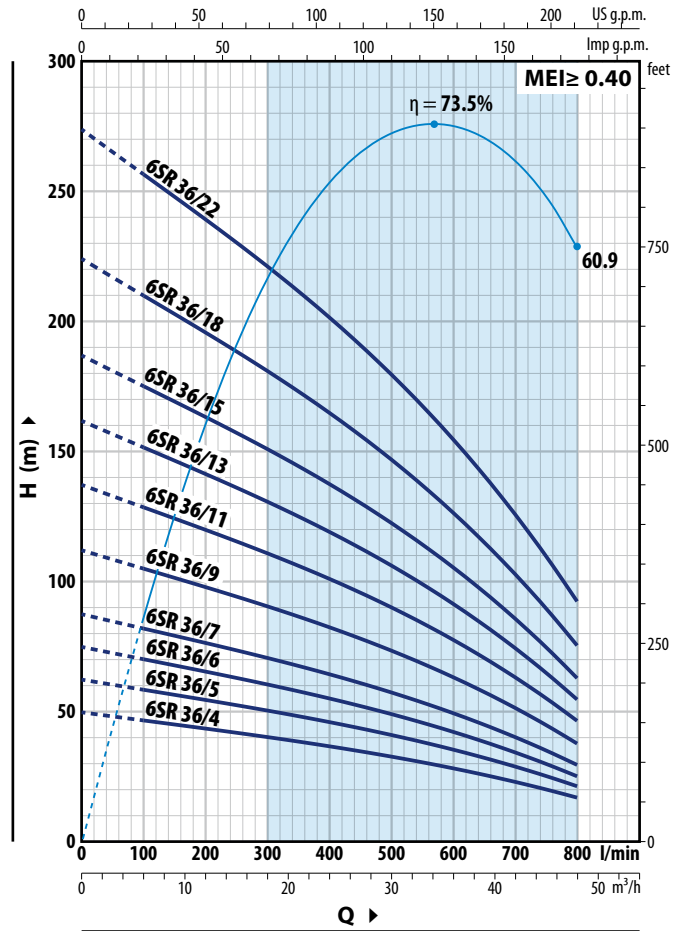

6SR 27

TYPE	POWER (P ₂)		Q	H metres									
	kW	HP		0	6	12	18	24	30	36			
Three-phase			l/min	0	100	200	300	400	500	600			
6SR 27/4	4	5.5		54	53	49	45	40	30	18			
6SR 27/5	5.5	7.5		68	66	62	57	50	37	22			
6SR 27/7	7.5	10		95	92	87	80	70	52	31			
6SR 27/8	9.2	12.5		109	106	99	91	80	59	35			
6SR 27/10	11	15		136	132	124	114	100	74	44			
6SR 27/12	13	17.5		164	159	149	137	120	89	53			
6SR 27/14	15	20		191	185	174	160	140	104	62			
6SR 27/17	18.5	25		231	224	211	194	170	126	75			
6SR 27/20	22	30		272	264	248	228	200	148	88			
6SR 27/27	30	40		367	356	335	308	270	205	119			

6SR 36

TYPE	POWER (P ₂)		Q	H metres											
	kW	HP		0	6	12	18	24	30	36	42	48			
Three-phase			l/min	0	100	200	300	400	500	600	700	800			
6SR 36/4	4	5.5		50	46.5	43.5	40	36.5	32.5	28	23	17			
6SR 36/5	5.5	7.5		62.5	58.5	54.5	50.5	46	41	35	28.5	21			
6SR 36/6	5.5	7.5		75	70	65.5	60.5	55	49	42	34.5	25			
6SR 36/7	7.5	10		87	82	76	70	64	57	49	40	29.5			
6SR 36/9	9.2	12.5		112	105	98	91	83	74	63.5	51.5	37.5			
6SR 36/11	11	15		137	128	120	111	101	90	77	63	46			
6SR 36/13	13	17.5		162	152	142	131	119	106	91	74.5	54.5			
6SR 36/15	15	20		187	175	163	151	138	123	105	86	63			
6SR 36/18	18.5	25		224	210	196	181	165	147	127	103	75			
6SR 36/22	22	30		274	257	239	221	202	180	155	126	92			

Q = Flow rate H = Total manometric head

Performance curves comply with EN ISO 9906 Grade 3B tolerance limits.

CURVES AND PERFORMANCE DATA

50 Hz

6SR 44

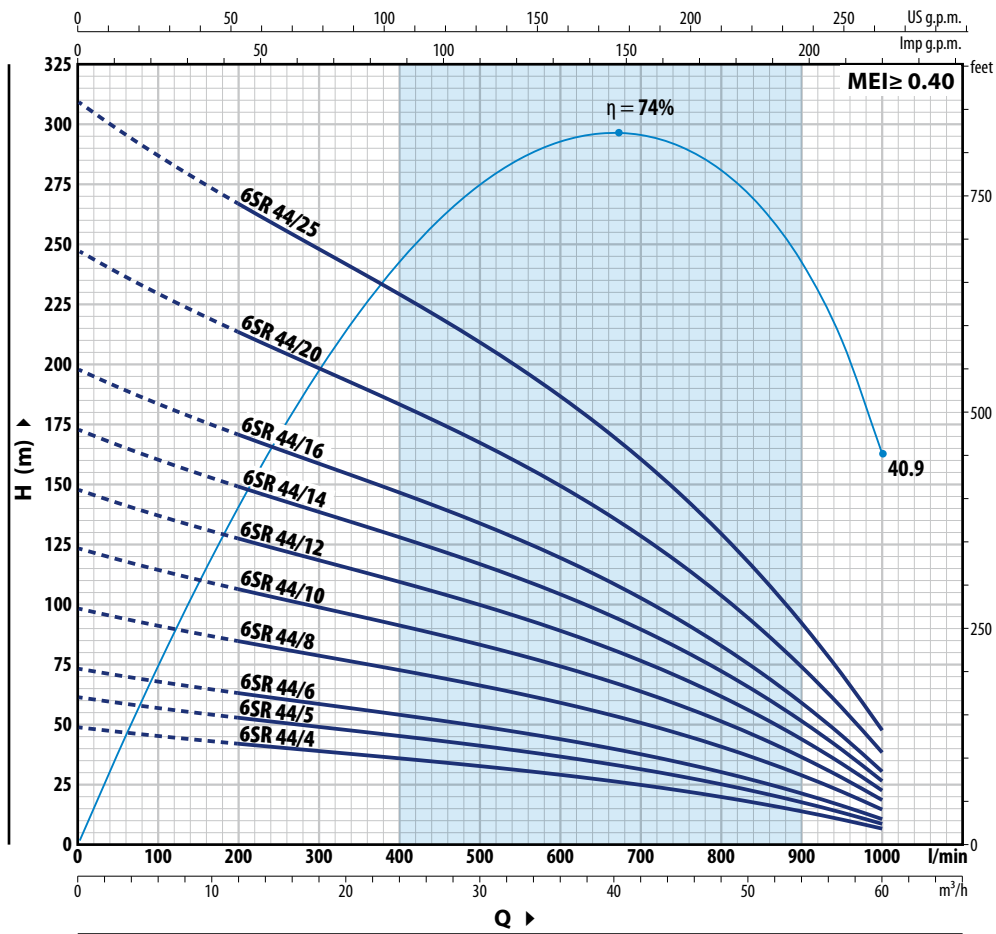

6SR 44

TYPE Three-phase	POWER (P ₂)		Q	Flow Rate (Q)												
	kW	HP		m ³ /h	0	12	18	24	30	36	42	48	54	60		
			l/min	0	200	300	400	500	600	700	800	900	1000			
6SR 44/4	4	5.5	H metres	49.5	43	40	37	33.5	30	25.8	21	15	8			
6SR 44/5	5.5	7.5		62	53.5	49.5	46	42	37.5	32.5	26	18.7	10			
6SR 44/6	7.5	10		74	64	59.5	55	50.5	45	38.5	31.5	22.4	11.5			
6SR 44/8	9.2	12.5		99	86	80	74	67	60	51.5	41.5	30	15.5			
6SR 44/10	11	15		124	107	99	92	84	75	64.5	52	37.5	19.5			
6SR 44/12	13	17.5		149	128	119	110	101	90	77	62.5	45	23.5			
6SR 44/14	15	20		174	150	139	129	118	105	90	73	52.5	27.5			
6SR 44/16	18.5	25		198	171	159	147	134	120	103	83	59.5	31			
6SR 44/20	22	30		248	214	199	184	168	150	129	104	75	39			
6SR 44/25	30	40	310	267	249	230	210	188	161	130	93	49				

Q = Flow rate H = Total manometric head

Performance curves comply with EN ISO 9906 Grade 3B tolerance limits.

6SR 6" submersible pumps

EXAMPLES OF INSTALLATION

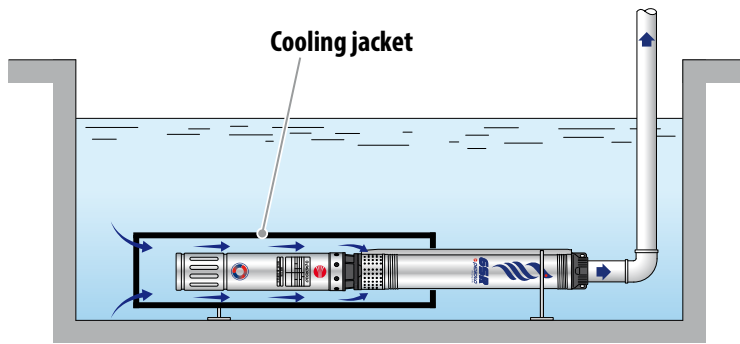

COOLING JACKET

✘ When the pump is installed in reservoirs, rivers, or lakes, it requires an external cooling jacket (flow generator) to ensure sufficient water flow across the motor surface, preventing overheating.



✘ The **6SR** pumps are suitable for wells with a minimum diameter of **6" (153 mm)**.

✘ The submersible pump must be lowered into the well through the delivery pipe to a depth that ensures it remains fully submerged, maintaining at least 50 cm or one metre from the bottom of the well, even if liquid levels decrease during operation.

✘ It is advisable to secure the submersible pump using a stainless-steel cable connected to appropriate attachments on the delivery port.

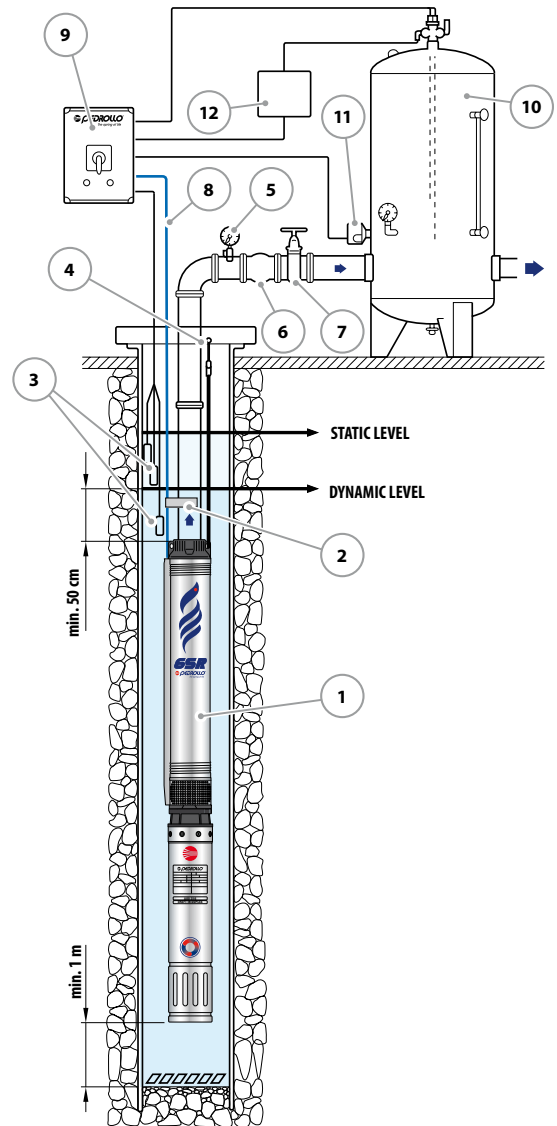

COMPONENTS

- 1) Submersible pump
- 2) Fixing Ties
- 3) Level control probes
- 4) Bracket and anchor cable
- 5) Pressure Gauge
- 6) Check valve
- 7) Flow control gate valve
- 8) Electrical power supply cable
- 9) Power switchboard
- 10) Autoclave tank
- 11) Pressure switch
- 12) Solenoid valve/electric compressor

MATERIALS AND COMPONENTS

1 Delivery port	Cast iron with cataphoresis treatment with thread according to ISO 228/1
2 Check valve	Stainless steel AISI 304 stainless steel
3 Motor bracket	Cast iron with cataphoresis treatment sized to NEMA standards
4 External sleeve	AISI 304 stainless steel
5 Impellers	Noryl™ and coated with special sand-resistant elastomer
6 Diffusers	Noryl™
7 Diffuser boxes	AISI 304 stainless steel
8 Pump shaft	AISI 304 stainless steel
9 Pump bearings	Made of AISI 316L stainless steel coated with chromium oxide to resist sand
10 Tow coupling	AISI 420 stainless steel
11 Filter	AISI 304 stainless steel
12 Cable sheath	AISI 304 stainless steel
13 Motor 6"	※ 6PD = rewindable oil filled motor ※ 6PSR = rewindable in water filled motor

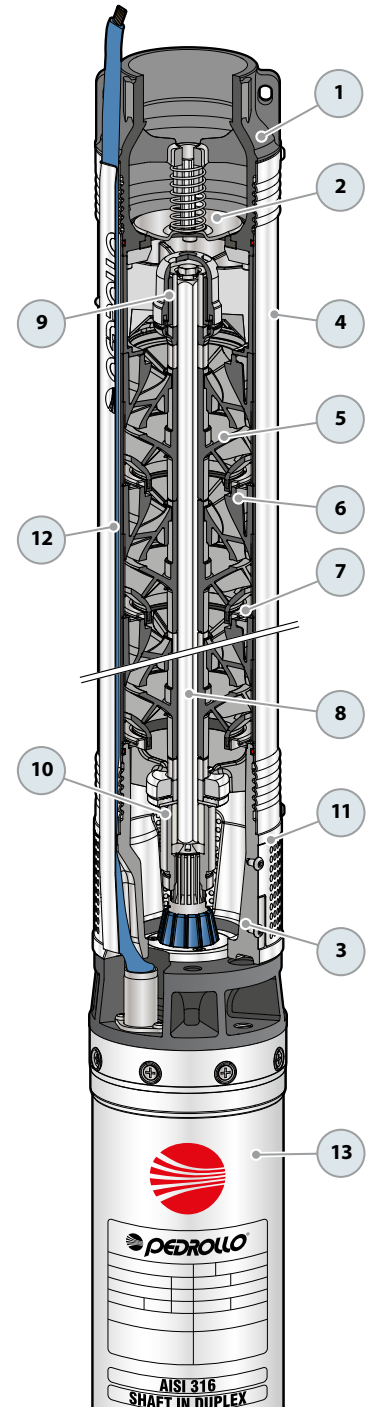

6SR 6" submersible pumps

DIMENSIONS AND WEIGHT

TYPE Three-phase ※	DN	DIMENSIONS mm			kg	TYPE Three-phase ※	DN	DIMENSIONS mm			kg
		h1	h2	h3							
6SR 12/8 - PD	3"	714	595	1309	55.0	6SR 12/8 - PSR	3"	714	620	1334	71.6
6SR 12/11 - PD		845	625	1470	58.3	6SR 12/11 - PSR		845	620	1465	73.9
6SR 12/15 - PD		1063	660	1723	67.8	6SR 12/15 - PSR		1063	670	1733	84.7
6SR 12/18 - PD		1193	700	1893	74.6	6SR 12/18 - PSR		1193	700	1893	91.0
6SR 12/21 - PD		1324	765	2089	83.6	6SR 12/21 - PSR		1324	750	2074	100.3
6SR 12/25 - PD		1497	820	2317	92.4	6SR 12/25 - PSR		1497	780	2277	106.4
6SR 12/28 - PD		1627	820	2447	94.8	6SR 12/28 - PSR		1627	840	2467	115.2
6SR 18/4 - PD		541	595	1136	50.5	6SR 18/4 - PSR		541	620	1161	67.1
6SR 18/6 - PD		628	625	1253	53.0	6SR 18/6 - PSR		628	620	1248	68.6
6SR 18/9 - PD		758	660	1418	60.4	6SR 18/9 - PSR		758	670	1428	77.3
6SR 18/11 - PD		845	700	1545	66.5	6SR 18/11 - PSR		845	700	1545	82.9
6SR 18/13 - PD		976	765	1741	76.4	6SR 18/13 - PSR		976	750	1726	93.1
6SR 18/15 - PD		1063	820	1883	83.6	6SR 18/15 - PSR		1063	780	1843	97.6
6SR 18/18 - PD		1193	820	2013	85.9	6SR 18/18 - PSR		1193	840	2033	106.3
6SR 18/22 - PD		1367	883	2250	98.8	6SR 18/22 - PSR		1367	890	2257	116.4
6SR 18/26 - PD		1541	953	2494	109.1	6SR 18/26 - PSR		1541	975	2516	130.5
6SR 27/4 - PD		579	595	1174	51.0	6SR 27/4 - PSR		579	620	1199	67.6
6SR 27/5 - PD		632	625	1257	52.9	6SR 27/5 - PSR		632	620	1252	68.5
6SR 27/7 - PD		738	660	1398	59.8	6SR 27/7 - PSR		738	670	1408	76.7
6SR 27/8 - PD		790	700	1490	65.2	6SR 27/8 - PSR		790	700	1490	81.6
6SR 27/10 - PD	896	765	1661	72.6	6SR 27/10 - PSR	896	750	1646	89.3		
6SR 27/12 - PD	1047	820	1867	82.8	6SR 27/12 - PSR	1047	780	1827	96.8		
6SR 27/14 - PD	1153	820	1973	84.5	6SR 27/14 - PSR	1153	840	1993	104.9		
6SR 27/17 - PD	1311	883	2194	97.0	6SR 27/17 - PSR	1311	890	2201	114.6		
6SR 27/20 - PD	1470	953	2423	106.9	6SR 27/20 - PSR	1470	975	2445	127.3		
6SR 27/27 - PD	1840	1098	2938	130.1	6SR 27/27 - PSR	1840	1215	3055	165.9		

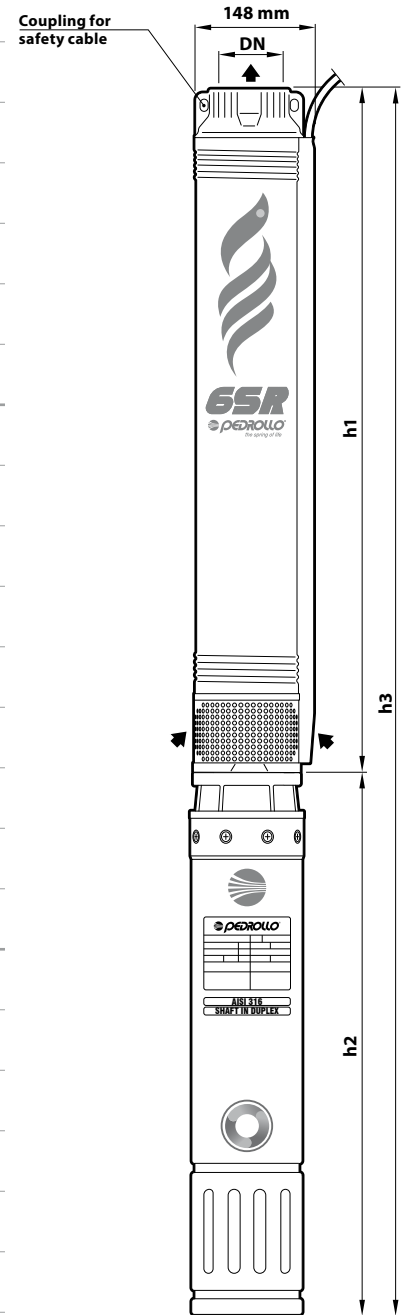

※ 6PD = rewindable oil filled motor

※ 6PSR = rewindable water filled motor

DIMENSIONS AND WEIGHT

TYPE Three-phase ※	DN	DIMENSIONS mm			kg	TYPE Three-phase ※	DN	DIMENSIONS mm			kg		
		h1	h2	h3									
6SR 36/4 - PD	3"	761	595	1356	54.9	6SR 36/4 - PSR	3"	761	620	1381	71.5		
6SR 36/5 - PD		859	625	1484	57.6	6SR 36/5 - PSR		859	620	1479	73.2		
6SR 36/6 - PD		958	625	1583	59.1	6SR 36/6 - PSR		958	620	1578	74.7		
6SR 36/7 - PD		1056	660	1716	66.3	6SR 36/7 - PSR		1056	670	1726	83.2		
6SR 36/9 - PD		1253	700	1953	73.9	6SR 36/9 - PSR		1253	700	1953	90.3		
6SR 36/11 - PD		1450	765	2215	83.8	6SR 36/11 - PSR		1450	750	2200	100.5		
6SR 36/13 - PD		1646	820	2466	92.5	6SR 36/13 - PSR		1646	780	2426	106.5		
6SR 36/15 - PD		1843	820	2663	96.7	6SR 36/15 - PSR		1843	840	2683	117.1		
6SR 36/18 - PD		2138	883	3021	109.1	6SR 36/18 - PSR		2138	890	3028	126.7		
6SR 36/22 - PD		2532	953	3485	123.5	6SR 36/22 - PSR		2532	975	3507	143.9		
6SR 44/04 - PD		3"	761	595	1356	54.9		6SR 44/04 - PSR	3"	761	620	1381	71.5
6SR 44/05 - PD			859	625	1484	57.6		6SR 44/05 - PSR		859	620	1479	73.2
6SR 44/06 - PD			958	660	1618	62.8		6SR 44/06 - PSR		958	670	1628	79.7
6SR 44/08 - PD			1154	700	1854	72.4		6SR 44/08 - PSR		1154	700	1854	88.8
6SR 44/10 - PD			1351	765	2116	82.1		6SR 44/10 - PSR		1351	750	2101	98.8
6SR 44/12 - PD			1548	820	2368	91.0		6SR 44/12 - PSR		1548	780	2328	105.0
6SR 44/14 - PD	1745		820	2565	95.1	6SR 44/14 - PSR	1745	840		2585	115.5		
6SR 44/16 - PD	1942		883	2825	107.0	6SR 44/16 - PSR	1942	890		2832	124.6		
6SR 44/20 - PD	2335		953	3288	119.5	6SR 44/20 - PSR	2335	975		3310	139.9		
6SR 44/25 - PD	2827		1098	3925	144.2	6SR 44/25 - PSR	2827	1215		4042	175.2		

※ **6PD** = rewindable oil filled motor

※ **6PSR** = rewindable water filled motor

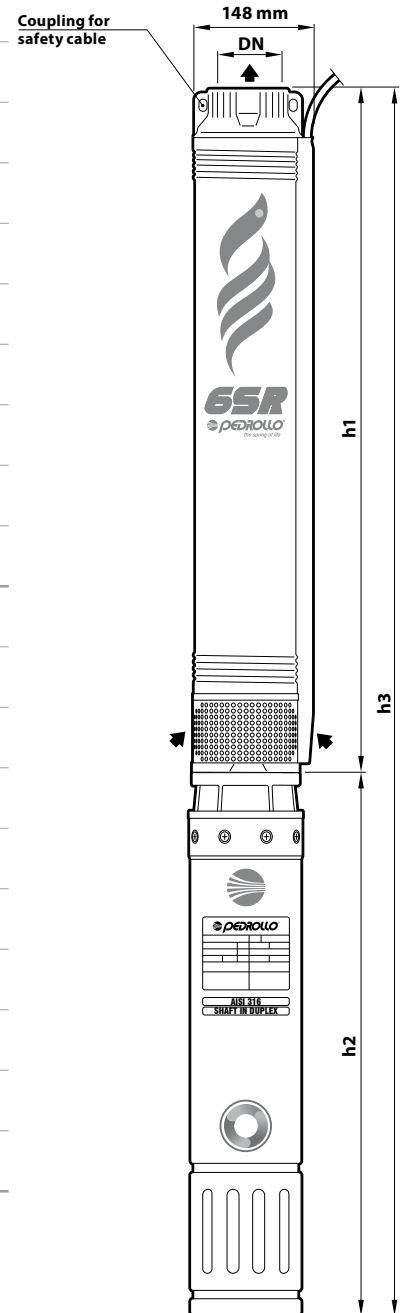



Clean water



Civil use



Agricultural use



Industrial use

※ For reliable performance in tough conditions, our stainless steel pumps, such as the 6ST series, are recommended for their high quality, ensuring a long service life with exceptional mechanical strength and corrosion resistance.

PERFORMANCE RANGE

- Flow rate up to **1300 l/min** (78 m³/h)
- Head up to **490 m**

INSTALLATION AND USE

Experience exceptional energy savings with our completely stainless steel 6" submersible borehole pumps, the **6ST** series. Engineered with optimized diffuser and impeller geometry, they deliver unmatched efficiency.

Designed to transfer clean water with sand content up to **100 g/m³**. Highly efficient and reliable, they are suitable for **industrial, civil, and agricultural applications**, such as water distribution coupled with pressure tanks, irrigation, pressure boosting, fire-fighting systems, and more.

INCLUDES

- ※ Three-phase electric motor 400 V - 50 Hz The pump can be supplied with motor:
 - **6PD** rewindable and oil filled
 - **6PSR** rewindable and water filled
- ※ **4 m** power cable

APPLICATION LIMITS

- Liquid temperature up to **+35 °C**
- Sand content max. **100 g/m³**
- Maximum operating depth below water level:
 - **200 m** with 6PD motors
 - **150 m** with 6PSR motors
- Vertical operation
- Starts per hour: **20** at regular intervals
- Minimum cooling flow **8 cm/s**
- Continuous running duty **S1**

AVAILABLE UPON REQUEST

- ※ 6ST pumps with double cable cover for coupling with 400/690 V
 - ▲/△ dual voltage motors (star/delta)
- ※ Other voltages

PERFORMANCE RANGE

50 Hz

6ST 17

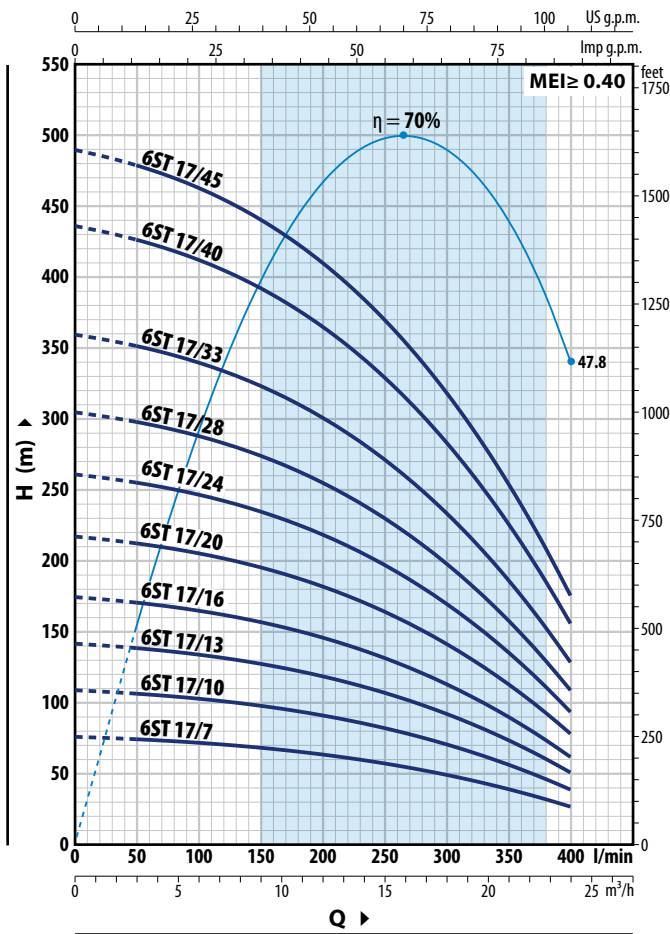

6ST 30

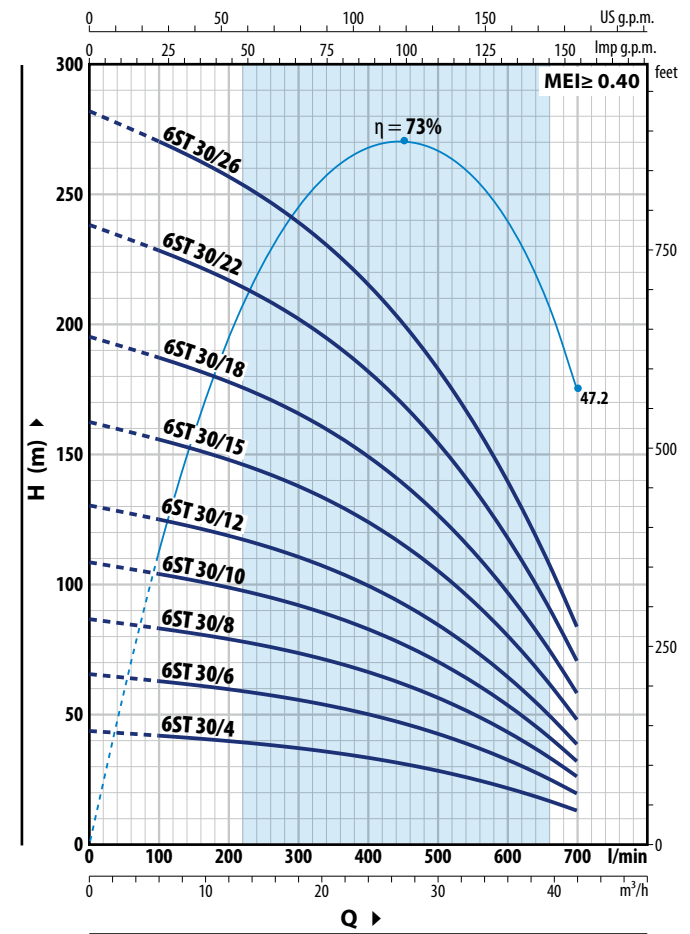

6ST 17

TYPE	POWER (P ₂)		Q	m ³ /h													
	kW	HP		0	3	6	9	12	15	18	21	24					
Three-phase			l/min	0	50	100	150	200	250	300	350	400					
6ST 17/7	4	5.5	H metres	76	75	72	68.5	64	57.5	49.5	39.5	27.5					
6ST 17/10	5.5	7.5		109	107	103	98	91	82	71	56.5	39					
6ST 17/13	7.5	10		142	139	134	127	119	107	92	73	50.5					
6ST 17/16	9.2	12.5		174	170	165	157	146	132	113	90	62.5					
6ST 17/20	11	15		218	213	206	196	182	165	142	113	78					
6ST 17/24	13	17.5		262	256	247	235	219	198	170	136	94					
6ST 17/28	15	20		305	298	288	274	255	230	198	158	109					
6ST 17/33	18.5	25		360	352	340	323	301	272	234	187	129					
6ST 17/40	22	30		436	426	412	392	365	329	283	226	156					
6ST 17/45 ⁽¹⁾	26	35		490	479	464	441	411	370	319	254	175					

6ST 30

TYPE	POWER (P ₂)		Q	m ³ /h												
	kW	HP		0	6	12	18	24	30	36	42					
Three-phase			l/min	0	100	200	300	400	500	600	700					
6ST 30/4	4	5.5	H metres	43.5	41.5	39.5	37	33	28	21.5	13					
6ST 30/6	5.5	7.5		65	62.5	59.5	55	49.5	42	32.5	19.5					
6ST 30/8	7.5	10		87	83	79	74	66.5	56.5	43	25.5					
6ST 30/10	9.2	12.5		108	104	99	92	83	70	54	32					
6ST 30/12	11	15		130	125	119	110	99	84	64.5	38.5					
6ST 30/15	13	17.5		163	156	148	138	124	106	81	48					
6ST 30/18	15	20		195	187	178	166	149	127	97	58					
6ST 30/22	18.5	25		239	229	217	202	182	155	118	71					
6ST 30/26	22	30		282	270	257	239	215	183	140	84					

Q = Flow rate H = Total manometric head

Performance curves comply with EN ISO 9906 Grade 3B tolerance limits.

(1) For pumps equipped with 6PD motor: 40 HP motor

PERFORMANCE RANGE

50 Hz

6ST 46

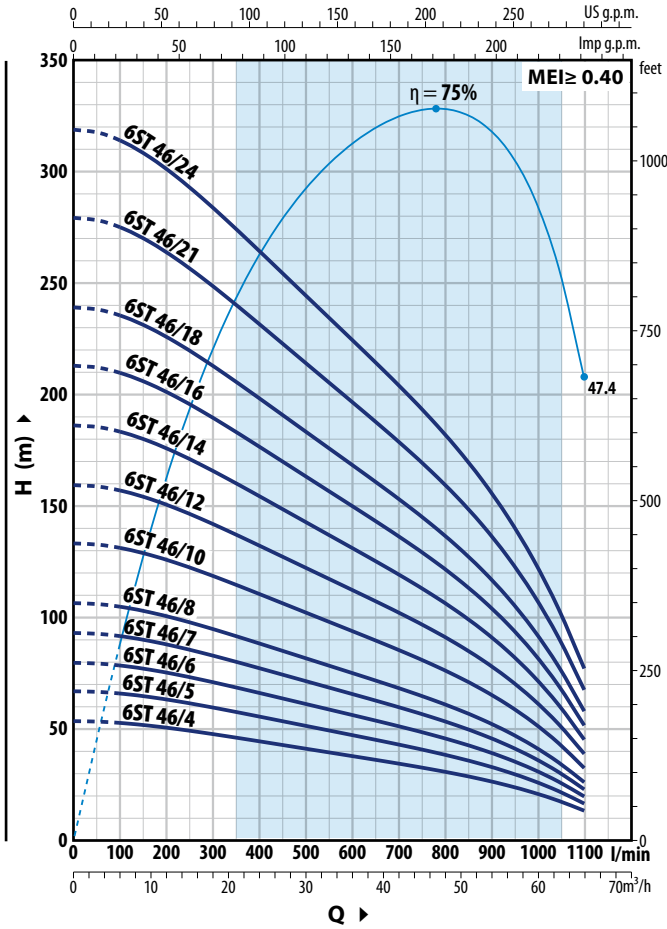

6ST 60

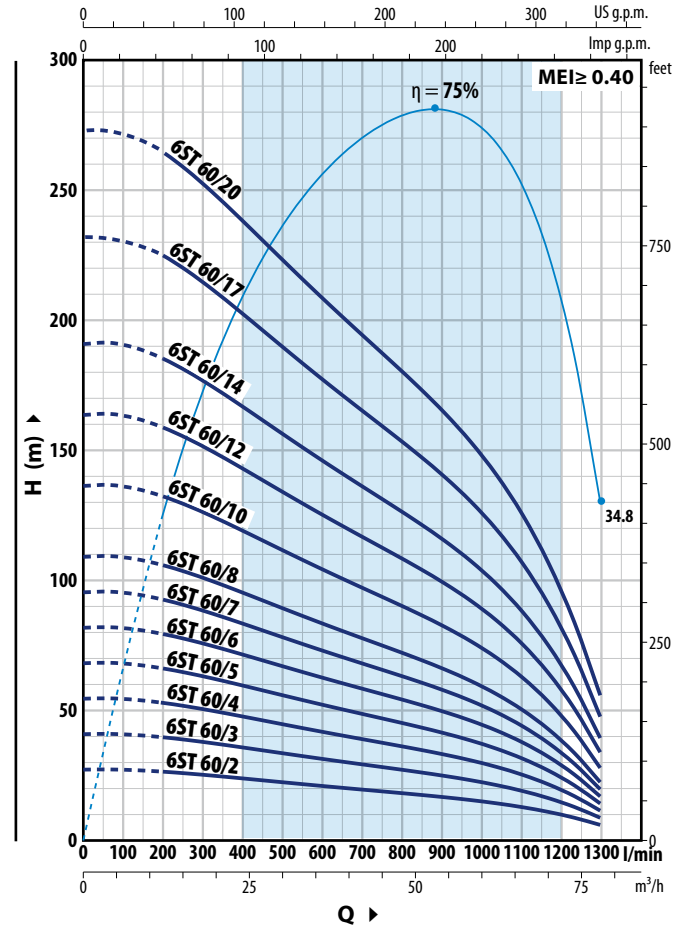

6ST 46

TYPE	POWER(P ₂)		Q	m ³ /h													
	kW	HP		0	6	12	18	24	30	36	42	48	54	60	66		
Three-phase				0	100	200	300	400	500	600	700	800	900	1000	1100		
6ST 46/4	5.5	7.5	H metres	53	52.5	50.5	47.5	44	41	37.5	34	30.5	26	20.4	13		
6ST 46/5	7.5	10		66.5	65.5	63	59	55	51	47	42.5	38	32.5	25.5	16		
6ST 46/6	9.2	12.5		80	79	75	71	66	61	56	51	45.5	39	30.5	19.5		
6ST 46/7	11	15		93	92	88	83	77	71	65.5	59.5	53	45.5	36	22.5		
6ST 46/8	13	17.5		106	105	101	95	88	82	75	68	61	52	41	26		
6ST 46/10	15	20		133	131	126	118	110	102	94	85	76	65	51	32		
6ST 46/12	18.5	25		160	157	151	142	132	122	112	102	91	78	61.5	38.5		
6ST 46/14	22	30		186	183	176	166	154	143	131	119	106	91	72	45		
6ST 46/16	22	30		213	210	201	189	177	163	150	136	122	104	82	51.5		
6ST 46/18 ⁽¹⁾	26	35		239	236	226	213	199	184	169	153	137	117	92	58		
6ST 46/21	30	40		279	275	264	249	232	214	197	179	160	137	107	67.5		
6ST 46/24	37	50		319	314	302	284	265	245	225	205	182	156	123	77		

6ST 60

TYPE	POWER(P ₂)		Q	m ³ /h											
	kW	HP		0	12	18	24	30	36	48	60	72	78		
Three-phase				0	200	300	400	500	600	800	1000	1200	1300		
6ST 60/2	4	5.5	H metres	27.5	26.5	25.3	24	22.4	21	18	15	9.7	5.5		
6ST 60/3	5.5	7.5		41	39.5	38	36	33.5	31.5	27	22.3	14.5	8.5		
6ST 60/4	7.5	10		54.5	53	50.5	47.5	44.5	42	36	29.5	19.4	11		
6ST 60/5	9.2	12.5		68.5	66	63	59.5	56	52.5	45	37	24.2	14		
6ST 60/6	11	15		82	79	76	72	67	62.5	54.5	44.5	29	17		
6ST 60/7	13	17.5		96	93	89	84	78	73	63.5	52	34	19.5		
6ST 60/8	15	20		109	106	101	95	89	84	72.5	59.5	39	22.5		
6ST 60/10	18.5	25		137	132	126	119	112	105	90	74	48.5	28		
6ST 60/12	22	30		164	159	152	143	134	125	109	89	58	33.5		
6ST 60/14 ⁽¹⁾	26	35		191	185	177	167	157	146	127	104	68	39		
6ST 60/17	30	40		232	225	215	203	190	178	154	126	82	47.5		
6ST 60/20	37	50		273	265	253	239	224	209	181	149	97	56		

(1) For pumps equipped with 6PD motor: 40 HP motor

MATERIALS AND COMPONENTS

1 Delivery port	AISI 304 stainless steel with thread according to ISO 228/1
2 Check valve	Stainless steel AISI 304
3 Motor bracket	Stainless steel AISI 304
4 Impellers	Stainless steel AISI 304
5 Diffusers	Stainless steel AISI 304
6 Pump shaft	Stainless steel AISI 304
7 Pump bearings	Special elastomer
8 Wear rings	Special elastomer
9 Tow coupling	Stainless steel AISI 304
10 Filter	Stainless steel AISI 304
11 Cable sheath	Stainless steel AISI 304
12 Motor 6"	※ 6PD = rewindable oil filled motor ※ 6PSR = rewindable oil water motor

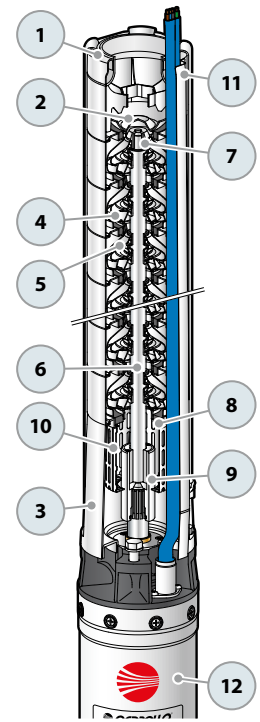

DIMENSIONS AND WEIGHT

TYPE	DN	DIMENSIONS mm			kg	TYPE	DN	DIMENSIONS mm			kg		
		h1	h2	h3				h1	h2	h3			
Three-phase ※						Three-phase ※							
6ST 17/7 - PD	3"	695	595	1290	48.8	6ST 17/7 - PSR	3"	695	620	1315	66.7		
6ST 17/10 - PD		876	625	1501	55.3	6ST 17/10 - PSR		876	620	1496	70.3		
6ST 17/13 - PD		1058	660	1718	63.3	6ST 17/13 - PSR		1058	670	1728	81.0		
6ST 17/16 - PD		1239	700	1939	69.4	6ST 17/16 - PSR		1239	700	1939	88.6		
6ST 17/20 - PD		1481	765	2246	79.2	6ST 17/20 - PSR		1481	750	2231	100.4		
6ST 17/24 - PD		1723	820	2543	95.0	6ST 17/24 - PSR		1723	780	2503	108.2		
6ST 17/28 - PD		1965	820	2785	99.8	6ST 17/28 - PSR		1965	840	2805	120.4		
6ST 17/33 - PD		2268	883	3151	117.4	6ST 17/33 - PSR		2268	890	3158	136.9		
6ST 17/40 - PD		2691	953	3644	132.3	6ST 17/40 - PSR		2691	975	3666	156.3		
6ST 17/45 - PD		2994	1098	4092	154.3	6ST 17/45 - PSR		2994	1075	4069	172.3		
6ST 30/4 - PD		3"	655	595	1250	46.2		6ST 30/4 - PSR	3"	655	620	1275	65.5
6ST 30/6 - PD			847	625	1472	54.2		6ST 30/6 - PSR		847	620	1467	69.2
6ST 30/8 - PD			1039	660	1699	62.1		6ST 30/8 - PSR		1039	670	1709	79.8
6ST 30/10 - PD			1231	700	1931	68.2		6ST 30/10 - PSR		1231	700	1931	87.4
6ST 30/12 - PD			1423	765	2188	76.8		6ST 30/12 - PSR		1423	750	2173	98.0
6ST 30/15 - PD			1711	820	2531	93.2		6ST 30/15 - PSR		1711	780	2491	106.4
6ST 30/18 - PD			1999	820	2819	98.7		6ST 30/18 - PSR		1999	840	2839	119.3
6ST 30/22 - PD			2383	883	3266	117.0		6ST 30/22 - PSR		2383	890	3273	137.0
6ST 30/26 - PD			2767	953	3720	131.0		6ST 30/26 - PSR		2767	975	3742	155.1
6ST 46/4 - PD			3"	723	625	1348		52.1		6ST 46/4 - PSR	3"	723	620
6ST 46/5 - PD	836			660	1496	56.6	6ST 46/5 - PSR	836		670		1506	74.3
6ST 46/6 - PD	949			700	1649	61.3	6ST 46/6 - PSR	949		700		1649	80.4
6ST 46/7 - PD	1062			765	1827	69.4	6ST 46/7 - PSR	1062		750		1812	90.6
6ST 46/8 - PD	1175			820	1995	81.6	6ST 46/8 - PSR	1175		780		1955	95.8
6ST 46/10 - PD	1401			820	2221	87.0	6ST 46/10 - PSR	1401		840		2241	107.6
6ST 46/12 - PD	1627			883	2510	102.9	6ST 46/12 - PSR	1627		890		2517	119.0
6ST 46/14 - PD	1853			953	2806	112.8	6ST 46/14 - PSR	1853		975		2828	133.4
6ST 46/16 - PD	2079			953	3032	118.2	6ST 46/16 - PSR	2079		975		3054	142.2
6ST 46/18 - PD	2305			1098	3403	138.6	6ST 46/18 - PSR	2305		1075		3380	156.6
6ST 46/21 - PD	2644			1098	3742	146.1	6ST 46/21 - PSR	2644		1215		3859	182.1
6ST 46/24 - PD	2983	1233		4216	162.7	6ST 46/24 - PSR	2983	1295	4278	198.7			
6ST 60/2 - PD	3"	497		595	1092	43.4	6ST 60/2 - PSR	3"	497	620		1117	61.3
6ST 60/3 - PD		610		625	1235	48.5	6ST 60/3 - PSR		610	620		1230	63.5
6ST 60/4 - PD		723		660	1383	54.4	6ST 60/4 - PSR		723	670		1393	72.1
6ST 60/5 - PD		836		700	1536	59.1	6ST 60/5 - PSR		836	700		1536	78.3
6ST 60/6 - PD		949		765	1714	67.3	6ST 60/6 - PSR		949	750		1699	88.4
6ST 60/7 - PD		1062		820	1882	79.4	6ST 60/7 - PSR		1062	780		1842	93.6
6ST 60/8 - PD		1175		820	1995	81.6	6ST 60/8 - PSR		1175	840		2015	102.2
6ST 60/10 - PD		1401		883	2284	97.5	6ST 60/10 - PSR		1401	890		2291	113.6
6ST 60/12 - PD		1627	953	2580	108.4	6ST 60/12 - PSR	1627		975	2602	129.0		
6ST 60/14 - PD		1853	1098	2951	128.8	6ST 60/14 - PSR	1853		1075	2928	143.4		
6ST 60/17 - PD	2192	1098	3290	137.4	6ST 60/17 - PSR	2192	1215	3407	172.4				
6ST 60/20 - PD	2531	1233	3764	153.9	6ST 60/20 - PSR	2531	1295	3826	189.9				

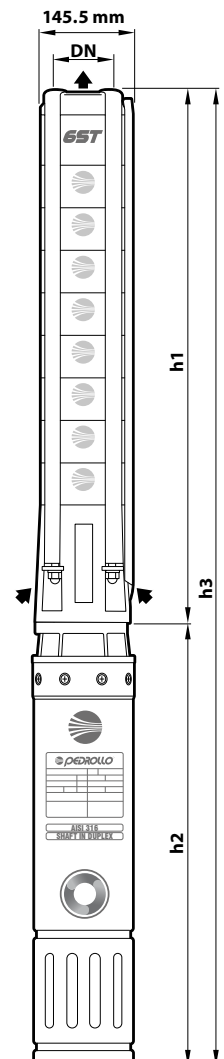

※ **6PD** = rewindable submersible oil filled motor

※ **6PSR** = rewindable submersible water filled motor



Clean water



Agricultural use



Civil use



Industrial use



✧ **Featuring high mechanical resistance against both sand abrasion and corrosion, even in marine environments or brackish water installations, the 4HR pump is the ideal choice when durability and quality are paramount.**

PERFORMANCE RANGE

- Flow rate up to **420 l/min** (25.2 m³/h)
- Head up to **176 m**

INSTALLATION AND USE

Submersible pump designed for 4" wells, constructed with durable micro-cast stainless steel.

Designed to transfer clean or brackish water with sand content up to 100 g/m³. Highly efficient and reliable, they are suitable for industrial, civil, and agricultural applications, such as water distribution coupled with pressure tanks, irrigation, pressure boosting, fire-fighting systems, and more.

INCLUDES

- ✧ Electric motor
 - Single-phase 230 V - 50 Hz
 - Three-phase 400 V - 50 Hz
- The pump can be supplied with a motor:
- **4PD** rewindable and oil filled
 - **4PS** encapsulated and water filled

- ✧ Power cable from:
 - **2 m** for power ratings from 0.37 to 2.2 kW
 - **3.6 m** for power ratings from 3 to 7.5 kW.

APPLICATION LIMITS

- Liquid temperature up to **+40 °C**
- Sand content max. **100 g/m³**
- Maximum operating depth below water level:
 - **200 m** with 4PD motors
 - **300 m** with 4PS motors
- Operation:
 - in vertical position
 - horizontally up to **12 stages**
- Starts per hour: **20** at regular intervals
- Minimum motor cooling flow **8 cm/s**
- Continuous running duty **S1**

AVAILABLE UPON REQUEST

- ✧ Different voltage requirements 60 Hz frequency

PATENTS - TRADE MARKS - MODELS

- Registered Community Model No. 004128619-0001

PERFORMANCE RANGE

50 Hz

4HR 10

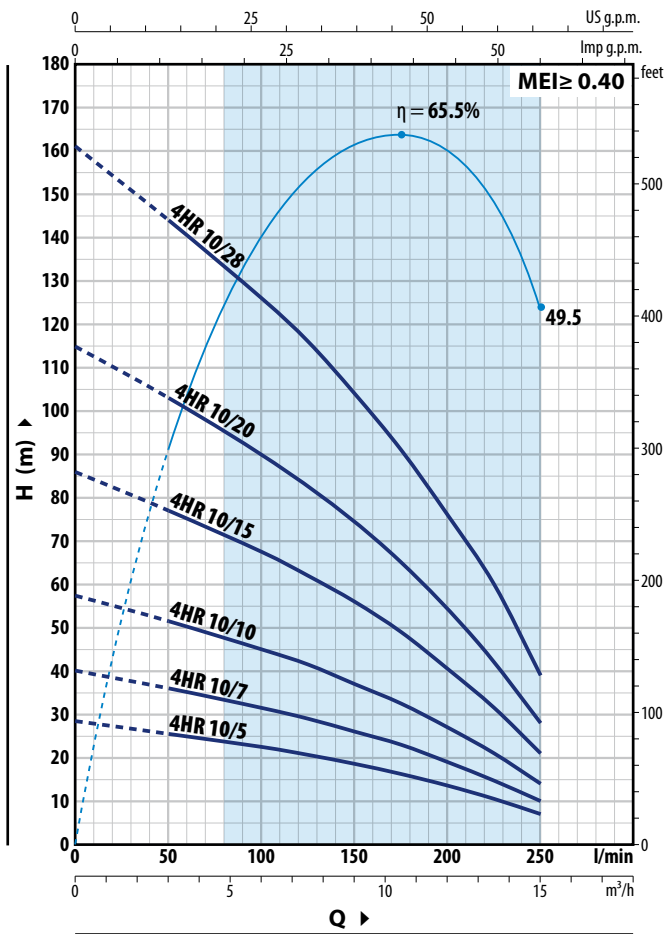

4HR 14

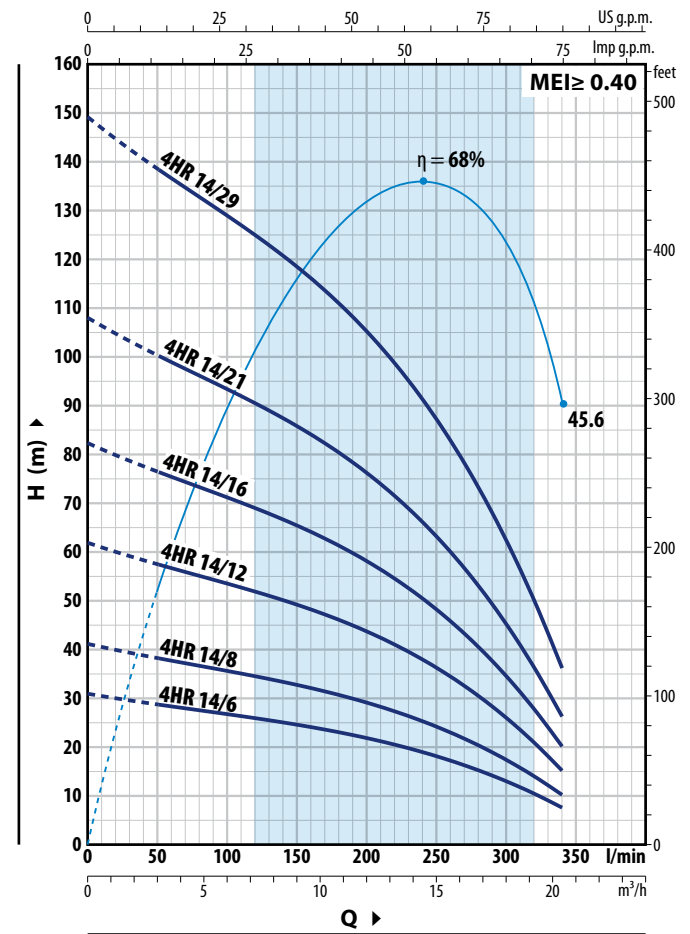

4HR 10

TYPE		POWER (P ₂)		Q	H metres									
Single-phase	Three-phase	kW	HP		m ³ /h	0	3.0	6.0	7.5	9.0	10.5	12.0	13.5	15.0
				l/min	0	50	100	125	150	175	200	225	250	
4HRm 10/5	4HR 10/5	0.75	1	H metres	28.5	25.5	22.5	20.7	18.6	16.3	13.6	10.5	7	
4HRm 10/7	4HR 10/7	1.1	1.5		40	36	31.5	29	26	23	19	14.7	10	
4HRm 10/10	4HR 10/10	1.5	2		57.5	51.5	45	41.5	37	32.5	27	21	14	
4HRm 10/15	4HR 10/15	2.2	3		86	77	67.5	62	56	49	40.5	31.5	21	
-	4HR 10/20	3	4		115	103	90	83	74	65	54.5	42	28	
-	4HR 10/28	4	5.5		161	144	126	116	104	91	76	60	39	

4HR 14

TYPE		POWER (P ₂)		Q	H metres									
Single-phase	Three-phase	kW	HP		m ³ /h	0	3.0	6.0	9.0	12.0	15.0	18.0	19.2	20.4
				l/min	0	50	100	150	200	250	300	320	340	
4HRm 14/6	4HR 14/6	1.1	1.5	H metres	31	28.5	26.7	24.5	21.8	18	13	10.4	7.5	
4HRm 14/8	4HR 14/8	1.5	2		41	38.5	35.5	32.5	29	24	17.2	13.8	10	
4HRm 14/12	4HR 14/12	2.2	3		62	57.5	53.5	49	43.5	36	25.8	20.7	15	
-	4HR 14/16	3	4		82	77	71	65.5	58	48	34.5	27.5	20	
-	4HR 14/21	4	5.5		108	100	93	86	76	63	45	36.5	26.5	
-	4HR 14/29	5.5	7.5		149	139	129	119	105	87	62.5	50	36.5	

Q = Flow rate H = Total manometric head

Performance curves comply with EN ISO 9906 Grade 3B tolerance limits.

4HR 18

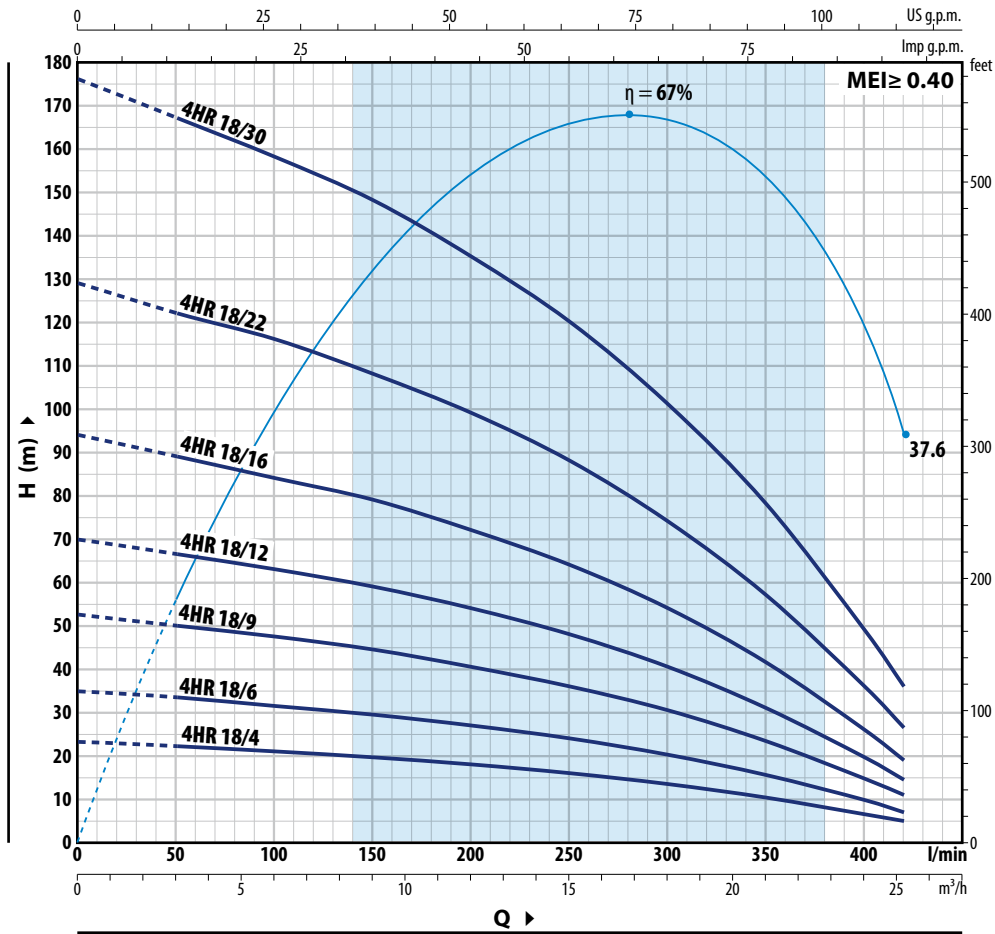

4HR 18

TYPE		POWER (P ₂)		Q	H metres											
Single-phase	Three-phase	kW	HP		m ³ /h	0	3.0	6.0	9.0	12.0	15.0	18.0	21.0	24.0	25.2	
				l/min	0	50	100	150	200	250	300	350	400	420		
4HRm 18/4	4HR 18/4	1.1	1.5		23.4	22	21	19.7	18	16	13.5	10.4	6.6	5		
4HRm 18/6	4HR 18/6	1.5	2		35	33.5	31.5	29.5	27	24	20.3	15.6	9.8	7		
4HRm 18/9	4HR 18/9	2.2	3		52.5	50	47.5	44.5	40.5	36	30.5	23.4	14.8	11		
-	4HR 18/12	3	4		70	66.5	63	59	54	48	40.5	31	19.7	14.5		
-	4HR 18/16	4	5.5		94	89	84	79	72	64	54	41.5	26	19		
-	4HR 18/22	5.5	7.5		129	122	116	108	99	88	74	57	36	26.5		
-	4HR 18/30	7.5	10		176	167	158	148	135	120	101	78	49	36		

Q = Flow rate H = Total manometric head

Performance curves comply with EN ISO 9906 Grade 3B tolerance limits.

MATERIALS AND COMPONENTS

1 Delivery port	Micro-cast AISI 304 stainless steel with thread according to ISO 228/1
2 Check valve	Stainless steel AISI 304
3 Motor bracket	AISI 304 micro-cast stainless steel sized to NEMA standards
4 Impellers	AISI 304 micro-cast stainless steel
5 Diffusers	AISI 304 micro-cast stainless steel
6 Pump shaft	Stainless steel AISI 304
7 Pump bearings	Special elastomer
8 Wear rings	Special elastomer
9 Tow coupling	Stainless steel AISI 304
10 Filter	Stainless steel AISI 304
11 Cable sheath	Stainless steel AISI 304
12 Motor 4"	※ 4PD = rewindable oil filled motor ※ 4PS = encapsulated water filled motor

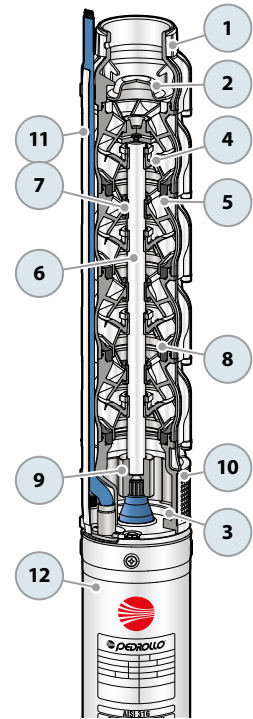

DIMENSIONS AND WEIGHT

TYPE Single-phase ※	DN	DIMENSIONS mm			kg	TYPE Single-phase ※	DN	DIMENSIONS mm			kg
		h1	h2	h3				h1	h2	h3	
4HRm 10/5 - PD	2"	511	356	867	19.0	4HRm 10/5 - PS	2"	511	272	783	20.3
4HRm 10/7 - PD		657	396	1053	22.5	4HRm 10/7 - PS		657	312	969	24.8
4HRm 10/10 - PD		876	437	1313	29.0	4HRm 10/10 - PS		876	352	1228	32.7
4HRm 10/15 - PD		1241	492	1733	39.2	4HRm 10/15 - PS		1241	402	1643	38.0
4HRm 14/6 - PD		584	396	980	20.5	4HRm 14/6 - PS		584	312	896	22.0
4HRm 14/8 - PD		730	437	1167	25.0	4HRm 14/8 - PS		730	352	1082	26.9
4HRm 14/12 - PD		1022	492	1514	33.5	4HRm 14/12 - PS		1022	402	1424	33.0
4HRm 18/4 - PD		438	396	834	18.1	4HRm 18/4 - PS		438	312	750	19.4
4HRm 18/6 - PD		584	437	1021	22.8	4HRm 18/6 - PS		584	352	936	24.3
4HRm 18/9 - PD		803	492	1295	29.5	4HRm 18/9 - PS		803	402	1205	29.1

TYPE Three-phase ※	DN	DIMENSIONS mm			kg	TYPE Three-phase ※	DN	DIMENSIONS mm			kg
		h1	h2	h3				h1	h2	h3	
4HR 10/5 - PD	2"	511	356	867	18.0	4HR 10/5 - PS	2"	511	257	768	18.3
4HR 10/7 - PD		657	371	1028	22.0	4HR 10/7 - PS		657	272	929	22.0
4HR 10/10 - PD		876	396	1272	26.8	4HR 10/10 - PS		876	297	1173	26.4
4HR 10/15 - PD		1241	437	1678	37.0	4HR 10/15 - PS		1241	352	1593	38.7
4HR 10/20 - PD		1606	450	2056	45.0	4HR 10/20 - PS		1606	484	2090	49.2
4HR 10/28 - PD		2190	625	2815	61.8	4HR 10/28 - PS		2190	574	2764	65.1
4HR 14/6 - PD		584	371	955	20.0	4HR 14/6 - PS		584	272	856	18.6
4HR 14/8 - PD		730	396	1126	23.2	4HR 14/8 - PS		730	297	1027	24.2
4HR 14/12 - PD		1022	437	1459	30.4	4HR 14/12 - PS		1022	352	1374	32.1
4HR 14/16 - PD		1314	450	1764	36.8	4HR 14/16 - PS		1314	484	1798	40.6
4HR 14/21 - PD		1679	625	2304	50.2	4HR 14/21 - PS		1679	574	2253	53.5
4HR 14/29 - PD		2263	725	2988	68.2	4HR 14/29 - PS		2263	664	2927	68.6
4HR 18/4 - PD		438	371	809	17.0	4HR 18/4 - PS		438	272	710	17.5
4HR 18/6 - PD		584	396	980	20.5	4HR 18/6 - PS		584	297	881	22.0
4HR 18/9 - PD		803	437	1240	27.0	4HR 18/9 - PS		803	352	1155	28.5
4HR 18/12 - PD		1022	450	1472	31.8	4HR 18/12 - PS		1022	484	1506	35.6
4HR 18/16 - PD		1314	625	1939	43.7	4HR 18/16 - PS		1314	574	1888	45.8
4HR 18/22 - PD		1752	725	2477	59.4	4HR 18/22 - PS		1752	664	2416	60.4
4HR 18/30 - PD		2336	845	3181	74.0	4HR 18/30 - PS		2336	764	3100	73.2

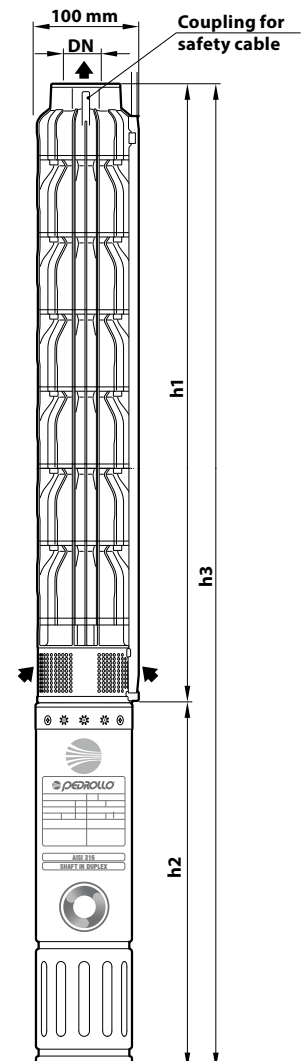

※ **4PD = rewindable oil filled motor**

※ **4PS = encapsulated water filled motor**



Clean water



Agricultural use



Civil use



Industrial use

✳️ **Distinguished by their exceptional mechanical resilience, our pumps excel in combating both sand wear and corrosion, making them perfect for coastal installations and brackish water environments. They are the optimal choice when seeking a high-quality product that ensures long-term operation.**

PERFORMANCE RANGE

- Flow rate up to **1500 l/min** (90 m³/h)
- Head up to **375 m**

INSTALLATION AND USE

Submersible pump designed for 6" wells, constructed with durable micro-cast stainless steel.

Designed to transfer clean or brackish water with sand content up to **100 g/m³**. Highly efficient and reliable, they are suitable for industrial, civil, and agricultural applications, such as water distribution coupled with pressure tanks, irrigation, pressure boosting, fire-fighting systems, and more.

INCLUDES

- ✳️ Three-phase electric motor 400 V - 50 Hz The pump can be supplied with motor:
 - 6PD rewindable and oil filled
 - 6PSR rewindable and water filled
- ✳️ **4 m** power cable

APPLICATION LIMITS

- Liquid temperature up to **+40 °C**
- Sand content max. **100 g/m³**
- Maximum operating depth below water level:
 - **200 m** with 6PD motors
 - **150 m** with 6PSR motors
- Operation:
 - in vertical position
 - horizontally with the following limits:
 - 6HR34 up to **11 stages** / 6HR44 up to **10 stages**
 - 6HR54 up to **9 stages** / 6HR64 up to **7 stages**
- Starts per hour: **20** at regular intervals
- Minimum cooling flow **8 cm/s**
- Continuous running duty **S1**

AVAILABLE UPON REQUEST

- ✳️ Different voltage requirements 60 Hz frequency
- ✳️ Counterflange kit
- ✳️ 6HR-HYD pumps with double cable cover for coupling with 400/690 V dual voltage motors ⚡/⚡ (star/delta)

PATENTS - TRADE MARKS - MODELS

- Registered Community Model No. 004675106-0002

PERFORMANCE RANGE

50 Hz

6HR 34

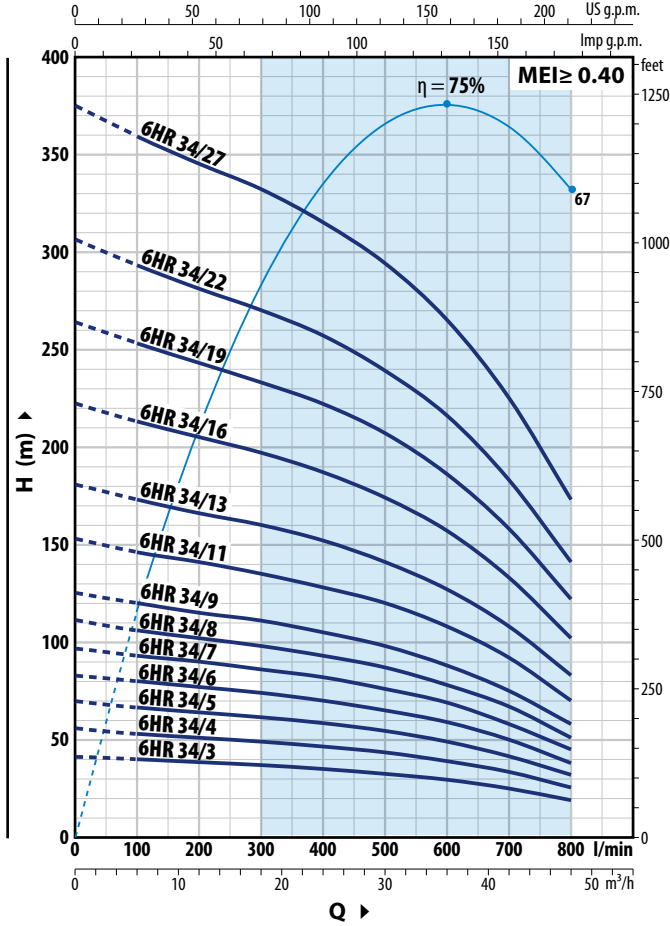

6HR 44

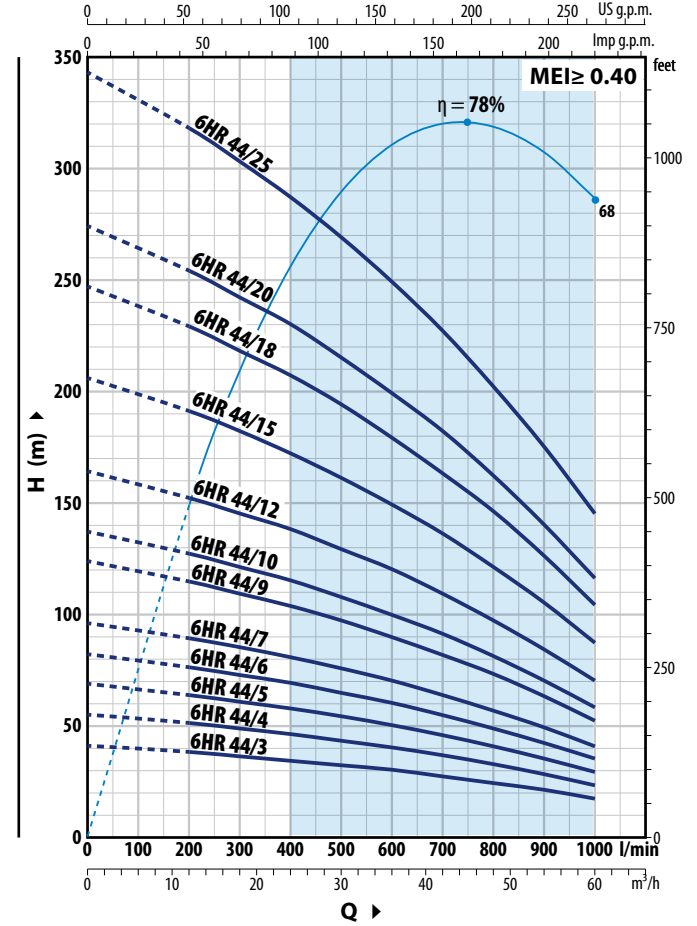

6HR 34

TYPE	POWER (P ₂)		Q	m ³ /h											
	kW	HP		0	6	12	18	24	30	36	42	48			
Three-phase				0	100	200	300	400	500	600	700	800			
6HR 34/3	4	5.5	H metres	41.5	40	38.5	37	35	32.5	29.5	25	19			
6HR 34/4	5.5	7.5		55.5	53	51	49	46.5	43.5	39	33.5	25.5			
6HR 34/5	7.5	10		69.5	66.5	64	61.5	58.5	54.5	49	41.5	32			
6HR 34/6	9.2	12.5		83	80	77	74	70	65	59	50	38			
6HR 34/7	11	15		97	93	90	86	82	76	69	58	45			
6HR 34/8	11	15		111	106	102	98	93	87	78	67	51			
6HR 34/9	13	17.5		125	120	115	111	105	98	88	75	58			
6HR 34/11	15	20		153	146	141	135	128	120	108	92	70			
6HR 34/13	18.5	25		181	173	166	160	152	141	127	108	83			
6HR 34/16	22	30		222	213	205	197	187	174	157	133	102			
6HR 34/19 ⁽¹⁾	26	35		264	253	243	233	222	207	186	158	122			
6HR 34/22	30	40		306	293	281	270	257	239	216	183	141			
6HR 34/27	37	50	375	359	345	332	315	294	265	225	173				

6HR 44

TYPE	POWER (P ₂)		Q	m ³ /h											
	kW	HP		0	12	18	24	30	36	42	48	54	60		
Three-phase				0	200	300	400	500	600	700	800	900	1000		
6HR 44/3	5.5	7.5	H metres	41	38	36	34	32	30	27	24	21	17		
6HR 44/4	7.5	10		55	51	48.5	46	43	40	36.5	32.5	28	23		
6HR 44/5	7.5	10		68.5	63.5	60.5	57.5	54	50	45.5	40.5	35	29		
6HR 44/6	9.2	12.5		82	76	72.5	69	64.5	60	54.5	48.5	42	35		
6HR 44/7	11	15		96	89	85	80.5	75.5	70	63.5	56.5	49	40.5		
6HR 44/9	13	17.5		123.5	114.5	109	103.5	97	89.5	81.5	73	63	52		
6HR 44/10	15	20		137	127	121	115	107.5	99.5	91	81	70	58		
6HR 44/12	18.5	25		164	152	145	138	129	120	109	97	84	70		
6HR 44/15	22	30		206	191	182	172	161	149	136	121	105	87		
6HR 44/18 ⁽¹⁾	26	35		247	229	218	207	194	179	163	146	126	104		
6HR 44/20	30	40		274	254	242	230	215	199	182	162	140	116		
6HR 44/25	37	50		343	318	303	287	269	249	227	202	175	145		

Q = Flow rate H = Total manometric head

Performance curves comply with EN ISO 9906 Grade 3B tolerance limits.

(1) For pumps equipped with 6PD motor: 40 HP motor

6HR

Microcast stainless steel 6" submersible pumps

PERFORMANCE RANGE

50 Hz

6HR 54

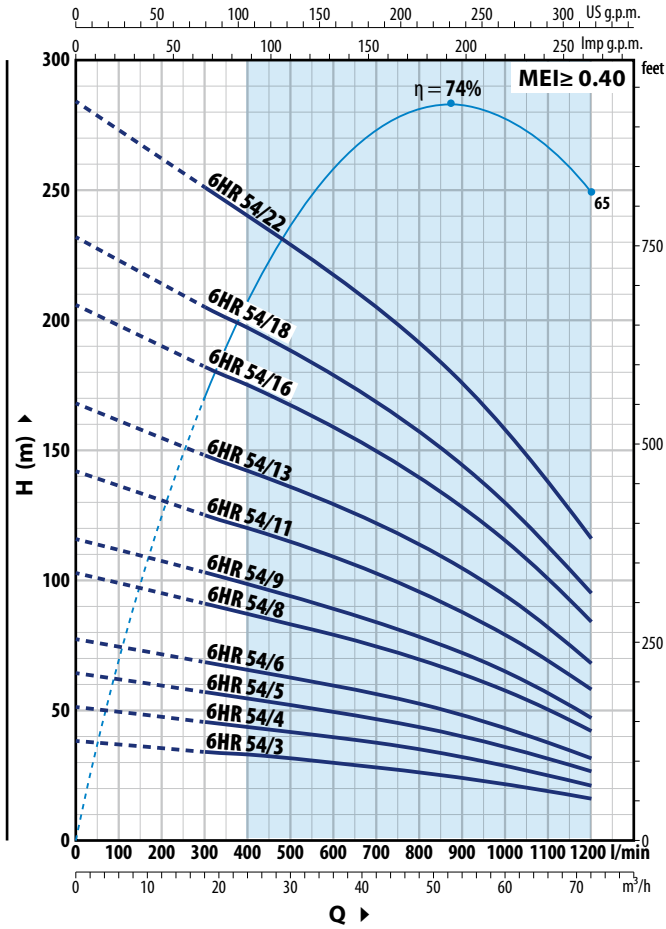

6HR 64

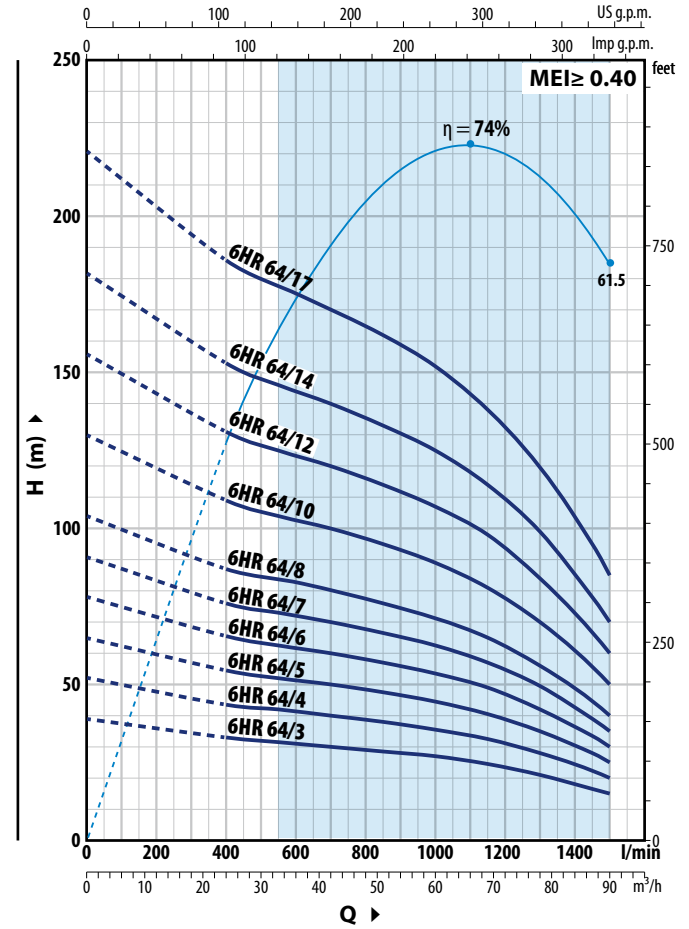

6HR 54

TYPE	POWER(P ₂)		Q	m ³ /h													
	kW	HP		0	18	24	30	36	42	48	54	60	66	72			
Three-phase				0	300	400	500	600	700	800	900	1000	1100	1200			
6HR 54/3	5.5	7.5	H metres	38.5	34	33	31.5	29.5	28	26	24	21.5	19	16			
6HR 54/4	7.5	10		51.5	45.5	43.5	41.5	39.5	37.5	35	32	29	25	21			
6HR 54/5	9.2	12.5		64.5	57	54.5	52	49.5	46.5	43.5	40	36	31.5	26.5			
6HR 54/6	11	15		77.5	68.5	65.5	62.5	59.5	56	52.5	48	43	37.5	31.5			
6HR 54/8	13	17.5		103	91	87	83	79	74.5	69.5	64	57.5	50.5	42			
6HR 54/9	15	20		116	103	98	94	89	84	78	72	65	57	47			
6HR 54/11	18.5	25		142	125	120	115	109	103	96	88	79	69	58			
6HR 54/13	22	30		168	148	142	136	129	121	113	104	94	82	68			
6HR 54/16 ⁽¹⁾	26	35		206	182	175	167	159	149	139	128	115	101	84			
6HR 54/18	30	40		232	205	197	188	178	168	157	144	130	113	95			
6HR 54/22	37	50	284	251	240	229	218	205	192	176	158	138	116				

6HR 64

TYPE	POWER(P ₂)		Q	m ³ /h										
	kW	HP		0	24	33	42	51	60	69	78	87	90	
Three-phase				0	400	550	700	850	1000	1150	1300	1450	1500	
6HR 64/3	7.5	10	H metres	39	33	31.5	30	28.5	27	24.5	21	16.5	15	
6HR 64/4	9.2	12.5		52	43.5	42	40	38	35.5	32.5	28	22.5	20	
6HR 64/5	11	15		65	54.5	52	50	47.5	44.5	40.5	35	28	25	
6HR 64/6	13	17.5		78	65.5	62.5	60	57	53.5	49	42	33.5	30	
6HR 64/7	15	20		91	76	73	70	66.5	62.5	57	49.5	39	35	
6HR 64/8	18.5	25		104	87	84	80	76	71	65	56	45	40	
6HR 64/10	22	30		130	109	104	100	95	89	81	70	56	50	
6HR 64/12 ⁽¹⁾	26	35		156	131	125	120	114	107	98	84	67	60	
6HR 64/14	30	40		182	153	146	140	133	125	114	99	78	70	
6HR 64/17	37	50		221	186	178	170	162	152	138	120	95	85	

(1) For pumps equipped with 6PD motor: 40 HP motor

MATERIALS AND COMPONENTS

1 Delivery port	Micro-cast AISI 304 stainless steel with thread according to ISO 228/1
2 Check valve	Stainless steel AISI 304
3 Motor bracket	AISI 304 micro-cast stainless steel sized to NEMA standards
4 Impellers	AISI 304 micro-cast stainless steel
5 Diffusers	AISI 304 micro-cast stainless steel
6 Pump shaft	Stainless steel AISI 304
7 Pump bearings	Special elastomer
8 Wear rings	Special elastomer
9 Tow coupling	Stainless steel AISI 304
10 Filter	Stainless steel AISI 304
11 Cable sheath	Stainless steel AISI 304
12 Motor 6"	※ 6PD = rewindable oil filled motor ※ 6PSR = rewindable water filled motor

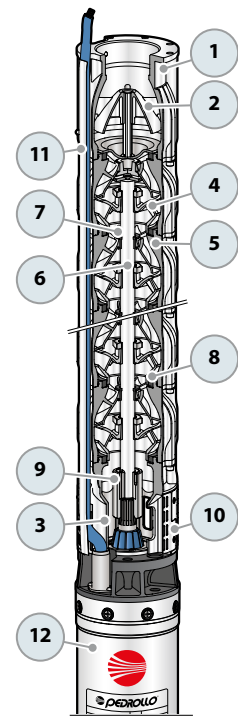

DIMENSIONS AND WEIGHT

TYPE	DN	DIMENSIONS mm			kg	TYPE	DN	DIMENSIONS mm			kg				
		h1	h2	h3				h1	h2	h3					
Three-phase ※						Three-phase ※									
6HR 34/3 - PD	3"	581	595	1176	53.1	6HR 34/3 - PSR	3"	581	620	1201	69.7				
6HR 34/4 - PD		682	625	1307	58.4	6HR 34/4 - PSR		682	620	1302	74.0				
6HR 34/5 - PD		783	660	1443	65.0	6HR 34/5 - PSR		783	670	1453	81.9				
6HR 34/6 - PD		884	700	1584	72.4	6HR 34/6 - PSR		884	700	1584	88.8				
6HR 34/7 - PD		985	765	1750	83.0	6HR 34/7 - PSR		985	750	1735	99.7				
6HR 34/8 - PD		1086	765	1851	85.8	6HR 34/8 - PSR		1086	750	1836	102.5				
6HR 34/9 - PD		1187	820	2007	94.4	6HR 34/9 - PSR		1187	780	1967	108.4				
6HR 34/11 - PD		1389	820	2209	101.2	6HR 34/11 - PSR		1389	840	2229	121.6				
6HR 34/13 - PD		1591	883	2474	115.8	6HR 34/13 - PSR		1591	890	2481	133.4				
6HR 34/16 - PD		1894	953	2847	132.6	6HR 34/16 - PSR		1894	975	2869	153.0				
6HR 34/19 - PD		2197	1098	3295	158.1	6HR 34/19 - PSR		2197	1075	3272	176.1				
6HR 34/22 - PD		2500	1098	3598	166.8	6HR 34/22 - PSR		2500	1215	3715	202.8				
6HR 34/27 - PD		3005	1233	4238	190.2	6HR 34/27 - PSR		3005	1295	4300	228.2				
6HR 44/3 - PD		3"	581	625	1206	54.1		6HR 44/3 - PSR	3"	581	620	1201	69.68		
6HR 44/4 - PD			682	660	1342	62.1		6HR 44/4 - PSR		682	670	1352	78.96		
6HR 44/5 - PD			783	660	1443	64.9		6HR 44/5 - PSR		783	670	1453	81.8		
6HR 44/6 - PD			884	700	1584	72.3		6HR 44/6 - PSR		884	700	1584	88.7		
6HR 44/7 - PD			985	765	1750	82.9		6HR 44/7 - PSR		985	750	1735	99.62		
6HR 44/9 - PD			1187	820	2007	94.4		6HR 44/9 - PSR		1187	780	1967	108.4		
6HR 44/10 - PD			1288	820	2108	98.3		6HR 44/10 - PSR		1288	840	2128	118.7		
6HR 44/12 - PD			1490	883	2373	112.9		6HR 44/12 - PSR		1490	890	2380	130.5		
6HR 44/15 - PD			1793	953	2746	129.7		6HR 44/15 - PSR		1793	975	2768	150.1		
6HR 44/18 - PD			2096	1098	3194	155.2		6HR 44/18 - PSR		2096	1075	3171	173.2		
6HR 44/20 - PD			2298	1098	3396	160.9		6HR 44/20 - PSR		2298	1215	3513	196.9		
6HR 44/25 - PD			2803	1233	4036	184.4		6HR 44/25 - PSR		2803	1295	4098	222.4		
6HR 54/3 - PD			3"	599	625	1224		54.3		6HR 54/3 - PSR	3"	599	620	1219	69.9
6HR 54/4 - PD				706	660	1366		62.4		6HR 54/4 - PSR		706	670	1376	79.3
6HR 54/5 - PD	813			700	1513	69.8	6HR 54/5 - PSR	813		700		1513	86.2		
6HR 54/6 - PD	920			765	1685	80.5	6HR 54/6 - PSR	920		750		1670	97.2		
6HR 54/8 - PD	1134			820	1954	92.1	6HR 54/8 - PSR	1134		780		1914	106.1		
6HR 54/9 - PD	1241			820	2061	96.1	6HR 54/9 - PSR	1241		840		2081	116.5		
6HR 54/11 - PD	1455			883	2338	110.8	6HR 54/11 - PSR	1455		890		2345	128.4		
6HR 54/13 - PD	1669			953	2622	124.9	6HR 54/13 - PSR	1669		975		2644	145.3		
6HR 54/16 - PD	1990			1098	3088	149.6	6HR 54/16 - PSR	1990		1075		3065	167.6		
6HR 54/18 - PD	2204			1098	3302	156.5	6HR 54/18 - PSR	2204		1215		3419	192.5		
6HR 54/22 - PD	2632			1233	3865	177.4	6HR 54/22 - PSR	2632		1295		3927	215.4		
6HR 64/3 - PD	3"			599	660	1259	58.0	6HR 64/3 - PSR		3"		599	670	1269	76.3
6HR 64/4 - PD				706	700	1406	66.9	6HR 64/4 - PSR				706	700	1406	83.3
6HR 64/5 - PD				813	765	1578	75.6	6HR 64/5 - PSR				813	750	1563	92.3
6HR 64/6 - PD				920	820	1740	86.2	6HR 64/6 - PSR				920	780	1700	100.2
6HR 64/7 - PD		1027		820	1847	89.2	6HR 64/7 - PSR	1027	840			1867	109.6		
6HR 64/8 - PD		1134		883	2017	100.9	6HR 64/8 - PSR	1134	890			2024	118.5		
6HR 64/10 - PD		1348		953	2301	115.1	6HR 64/10 - PSR	1348	975			2323	135.5		
6HR 64/12 - PD		1562		1098	2660	138.0	6HR 64/12 - PSR	1562	1075			2637	152.4		
6HR 64/14 - PD		1776		1098	2874	143.9	6HR 64/14 - PSR	1776	1215			2991	174.9		
6HR 64/17 - PD		2097		1233	3330	161.6	6HR 64/17 - PSR	2097	1295			3392	199.6		

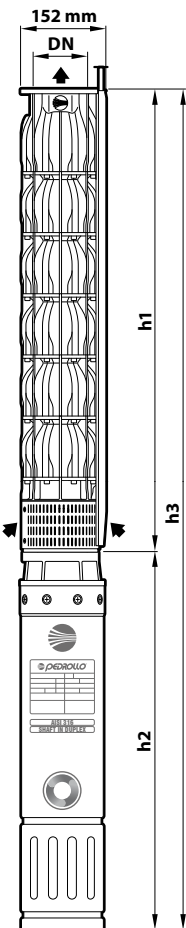

COUNTERFLANGE

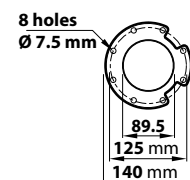

※ **6PD** = rewindable oil filled motor

※ **6PSR** = rewindable water filled motor

※ High-quality submersible motors made of premium AISI 316 and DUPLEX materials for a long service life

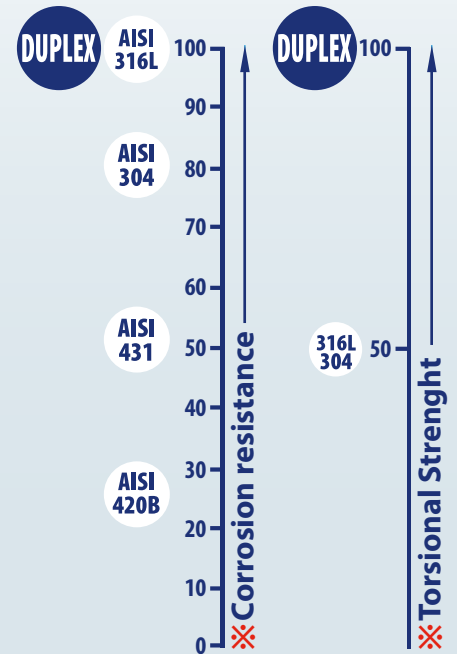

※ DUPLEX stainless steel shaft
 ※ AISI 316 casing

※ DUPLEX steel is recognized for its outstanding mechanical strength, which is twice that of AISI 304/316L steel.

ELECTRIC MOTOR

Our 4" submersible oil-filled motors are crafted from top-tier materials and designed with industry expertise. They ensure exceptional performance, superior quality, and maintenance-free longevity.

TECHNICAL DATA

- 2 poles, 50 Hz ($n \approx 2900 \text{ min}^{-1}$)
- Voltage:
 - single-phase 230 V
 - three-phase 400 V
- Power from 0.37 to 7.5 kW
- Continuous running duty S1
- Class F insulation and IP 68 protection

AVAILABLE UPON REQUEST

※ Different voltage requirements 60 Hz frequency

MATERIALS AND COMPONENTS

- ※ **Rewindable** motor in oil bath (non-toxic food-safe oil)
- ※ Sleeve: AISI 316 stainless steel
- ※ Coupling dimensions in compliance with NEMA standards.

※ Power cable included:

- 2 m for power ratings from 0.37 to 2.2 kW
- 3.6 m for powers from 3 to 7.5 kW

※ Shaft: 'DUPLEX' stainless steel

APPLICATION LIMITS

- Liquid temperature up to +40 °C
- Depth of use up to 200 m below water level
- Starts per hour: max. 20 at regular intervals
- Minimum cooling flow 8 cm/s

CORROSION CONTROL

The sacrificial anode, composed of a 'cadmium-free' zinc-aluminum alloy safe for potable water, is simple to attach to 4PD motors. It shields against corrosion, especially from stray currents or aggressive water, thus greatly extending the lifespan of the motor and pump components.

Available upon request - code ASS4PDA01



PERFORMANCE DATA

50 Hz

※ Single-phase versions - 230 V / 50 Hz

TYPE	Rated power P ₂		Axial load N	Revolutions min ⁻¹	Starting current Current nominal	Power factor Cos φ	Capacitor (VL=450V) μF	h2 mm	Weight kg
	kW	HP							
Single-phase									
4PDm / 0.50	0.37	0.50	2000	2820	3.2	0.9	20	311	6.8
4PDm / 0.75	0.55	0.75		2830	3.2	0.9	25	331	7.9
4PDm / 1	0.75	1		2835	3	0.93	35	356	8.9
4PDm / 1.5	1.1	1.5		2850	3.1	0.93	40	396	10.7
4PDm / 2	1.5	2		2850	3.3	0.92	60	437	12.8
4PDm / 3	2.2	3		2830	3.2	0.95	75	492	14.9

※ Three-phase versions - 400 V / 50 Hz

TYPE	Rated power P ₂		Axial load N	Revolutions min ⁻¹	Starting current Current nominal	Power factor Cos φ	h2 mm	Weight kg
	kW	HP						
Three-phase								
4PD / 0.50	0.37	0.50	2000	2850	3.3	0.6	311	7.0
4PD / 0.75	0.55	0.75		2840	4.1	0.65	331	7.7
4PD / 1	0.75	1		2840	3.7	0.72	356	8.8
4PD / 1.5	1.1	1.5		2825	4.5	0.75	371	9.5
4PD / 2	1.5	2		2835	4	0.73	396	10.7
4PD / 3	2.2	3		2815	4.5	0.74	437	12.6
4PD / 4	3	4	3000	2840	5.5	0.81	450	13.7
4PD / 5.5	4	5.5	5000	2845	5.3	0.78	625	20.5
4PD / 7.5	5.5	7.5		2850	5.2	0.75	725	28.5
4PD / 10	7.5	10		2850	5.2	0.76	845	32.0

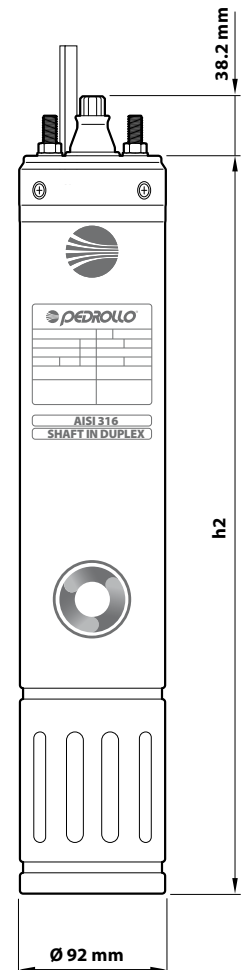

ABSORPTION

TYPE	VOLTAGE
Single-phase	230 V
4PDm / 0.50	3.6 A
4PDm / 0.75	4.7 A
4PDm / 1	5.9 A
4PDm / 1.5	8.3 A
4PDm / 2	10.7 A
4PDm / 3	15.2 A

TYPE	VOLTAGE	
Three-phase	230 V	400 V
4PD / 0.50	3.1 A	1.8 A
4PD / 0.75	3.5 A	2.0 A
4PD / 1	4.3 A	2.5 A
4PD / 1.5	5.9 A	3.4 A
4PD / 2	8.3 A	4.8 A
4PD / 3	10.6 A	6.1 A
4PD / 4	12.3 A	7.1 A
4PD / 5.5	17.0 A	9.8 A
4PD / 7.5	23.3 A	13.5 A
4PD / 10	-	17.5 A

※ Encapsulated water-filled motors ensure absolute operational safety

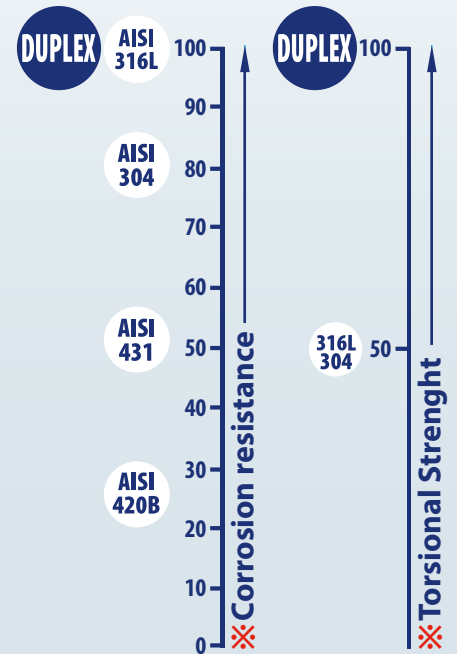

※ DUPLEX stainless steel shaft
 ※ AISI 316 casing

※ DUPLEX steel is recognized for its outstanding mechanical strength, which is twice that of AISI 304/316L steel.

ELECTRIC MOTOR

The **4PS** series encapsulated 4" submersible motors are ideal for applications where reliable, maintenance-free operation is crucial.

Featuring a special "canned" construction, these motors eliminate the need for mechanical sealing, ensuring total safety against water infiltration into the electrical winding.

TECHNICAL DATA

- 2 poles, 50 Hz ($n \approx 2900 \text{ min}^{-1}$)
- Voltage:
 - single-phase 230 V
 - three-phase 400 V
- Power from **0.37 to 7.5 kW**
- Continuous running duty **S1**
- Class F insulation and IP 68 protection

AVAILABLE UPON REQUEST

- ※ Other voltages

MATERIALS AND COMPONENTS

- ※ Encapsulated water filled submersible motors
- ※ **Sleeve: AISI 316 stainless steel**
- ※ **Shaft: 'DUPLEX' stainless steel**
- ※ Mating dimensions according to **NEMA** standard.
- ※ Power cable included:
 - **2 m** for power ratings from 0.37 to 2.2 kW
 - **3.6 m** for power ratings from 3 to 7.5 kW.

APPLICATION LIMITS

- Liquid temperature up to **+35 °C**
- Depth of use up to **300 m** below water level
- Starts per hour: max. **20** at regular intervals
- Minimum cooling flow **8 cm/s**

WARRANTY

- 3-Year Warranty Included in Our Standard Terms and Conditions

PERFORMANCE DATA

50 Hz

※ Single-phase versions - 230 V / 50 Hz

TYPE	Rated power		Axial load	Revolutions	Starting current Current nominal	Power factor	Capacitor (VL=450V)	h2	Weight
	P2 kW	HP							
Single-phase			N	min ⁻¹		Cos φ	μF	mm	kg
4PSm / 0.50	0.37	0.50	2000	2845	3.4	0.88	20	237	8.6
4PSm / 0.75	0.55	0.75		2840	3.8	0.93	25	257	9.0
4PSm / 1	0.75	1		2835	3.8	0.92	35	272	9.6
4PSm / 1.5	1.1	1.5		2820	3.3	0.91	40	312	11.5
4PSm / 2	1.5	2	3000	2830	3.2	0.94	60	352	13.2
4PSm / 3	2.2	3		2810	3.6	0.94	70	402	15.5

※ Three-phase versions - 400 V / 50 Hz

TYPE	Rated power		Axial load	Revolutions	Starting current Current nominal	Power factor	h2	Weight
	P2 kW	HP						
Three-phase			N	min ⁻¹		Cos φ	mm	kg
4PS / 0.50	0.37	0.50	2000	2855	4.2	0.64	237	8.1
4PS / 0.75	0.55	0.75		2835	4.1	0.70	237	8.1
4PS / 1	0.75	1		2830	4.4	0.68	257	9.0
4PS / 1.5	1.1	1.5		2825	4.6	0.69	272	9.6
4PS / 2	1.5	2	3000	2820	4.7	0.73	297	10.7
4PS / 3	2.2	3		2805	5.2	0.74	352	13.1
4PS / 4	3	4	6500	2845	5.7	0.82	484	18.3
4PS / 5.5	4	5.5		2850	5.9	0.78	574	22.5
4PS / 7.5	5.5	7.5		2845	5.9	0.84	664	26.7
4PS / 10	7.5	10	2830	5.8	0.84	764	31.6	

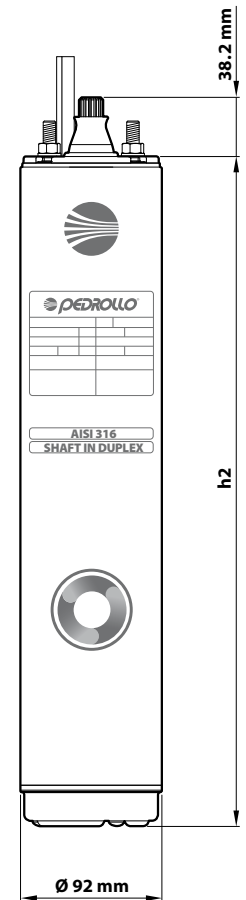

ABSORPTION

TYPE	VOLTAGE
Single-phase	230 V
4PSm / 0.50	3.5 A
4PSm / 0.75	4.4 A
4PSm / 1	5.9 A
4PSm / 1.5	8.1 A
4PSm / 2	10.7 A
4PSm / 3	16.2 A

TYPE	VOLTAGE
Three-phase	400 V
4PS / 0.50	1.6 A
4PS / 0.75	1.8 A
4PS / 1	2.5 A
4PS / 1.5	3.4 A
4PS / 2	4.3 A
4PS / 3	6.0 A
4PS / 4	6.9 A
4PS / 5.5	9.6 A
4PS / 7.5	12.4 A
4PS / 10	16.9 A

- ※ High-quality submersible motors made of premium **AISI 316 and DUPLEX** materials for a long service life

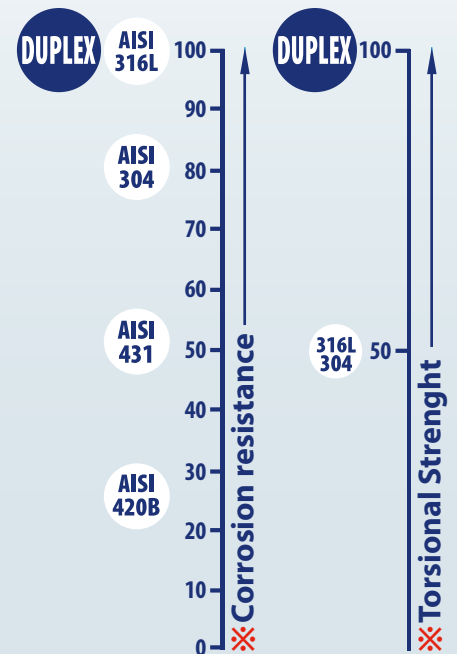

- ※ **DUPLEX** stainless steel shaft
- ※ **AISI 316** casing

- ※ **DUPLEX** steel is recognized for its outstanding mechanical strength, which is twice that of AISI 304/316L steel.

ELECTRIC MOTOR

6" submersible oil-filled motors are crafted from top-tier materials and designed with industry expertise.

They ensure exceptional performance, superior quality, and maintenance-free longevity.

TECHNICAL DATA

- 2 poles, 50 Hz ($n \approx 2900 \text{ min}^{-1}$)
- Three-phase voltage 400 V
- Power from **4 to 37 kW**
- Continuous running duty **S1**
- Class F insulation and IP 68 protection

AVAILABLE UPON REQUEST

- ※ Different voltage requirements 60 Hz frequency
- ※ Motors with double power cable for star/delta starting (**Y/Δ**)

MATERIALS AND COMPONENTS

- ※ Rewindable oil filled submersible motors (non-toxic food-safe oil).
- ※ **Sleeve: AISI 316 stainless steel**
- ※ **Shaft: 'DUPLEX' stainless steel**
- ※ Coupling dimensions in compliance with NEMA standards.
- ※ Power cable included:
 - **3 m** for power up to 15 kW
 - **4 m** for powers from 18.5 to 37 kW.

APPLICATION LIMITS

- Liquid temperature up to **+35 °C**
- Depth of use up to **200 m** below water level
- Starts per hour: **30** at regular intervals
- Minimum cooling flow **8 cm/s**

PERFORMANCE DATA

50 Hz

※ Three-phase versions - 400 V / 50 Hz

TYPE	Rated power P ₂		Axial load N	Revolutions min ⁻¹	Starting current Current nominal	Yield η	Power factor Cos φ	Rated torque Nm	Starting torque Torque rated	h2 mm	Weight kg
	kW	HP									
6PD / 5.5	4	5.5	10000	2840	5.1	74%	0.86	13.5	1.65	595	33.4
6PD / 7.5	5.5	7.5		2840	5.1	74%	0.84	18.5	1.60	625	34.4
6PD / 10	7.5	10		2850	4.7	78%	0.83	25.1	1.55	660	38.1
6PD / 12.5	9.2	12.5		2880	4.5	81%	0.77	30.5	1.60	700	42.6
6PD / 15	11	15		2850	5.2	85%	0.82	36.9	2.20	765	48.3
6PD / 20	15	20		2840	5.0	82%	0.86	50.5	2.60	820	58.0
6PD / 25	18.5	25	20000	2850	5.9	84%	0.84	62.0	2.30	883	62.8
6PD / 30	22	30		2850	5.5	84%	0.83	73.8	2.45	953	79.4
6PD / 40	30	40		2860	5.5	85%	0.83	100.2	1.90	1098	91.0
6PD / 50	37	50		2840	5.1	84%	0.83	124.5	2.10	1233	92.0

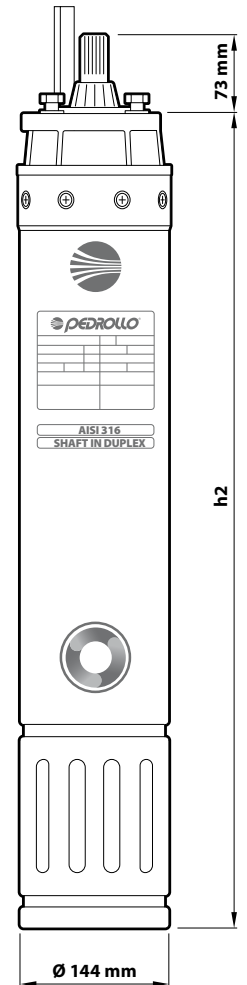

ABSORPTION

TYPE	VOLTAGE
Three-phase	400 V
6PD / 5.5	9.3 A
6PD / 7.5	12.9 A
6PD / 10	17.1 A
6PD / 12.5	21.8 A
6PD / 15	23.8 A
6PD / 20	31.6 A
6PD / 25	38.5 A
6PD / 30	46.5 A
6PD / 40	63.0 A
6PD / 50	78.0 A

※ **Rewindable water filled motors ensure absolute operational safety**



ELECTRIC MOTOR

Rewindable water-filled motors. The wound stator consists of copper wire coated with water-repellent thermoplastic material with high dielectric properties.

TECHNICAL DATA

- 2-pole electric motor, 50 Hz ($n \approx 2900 \text{ min}^{-1}$)
- Three-phase voltage **400 V**
- Power from **5.5 to 37 kW**
- Insulation: class Y
- Protection rating: IP 68

AVAILABLE UPON REQUEST

- ※ Different voltage requirements 60 Hz frequency
- ※ Motors with double power cable for starting star/triangle(Y/Δ)

MATERIALS AND COMPONENTS

- ※ **Rewindable** submersible motors in a **water filled**.
- ※ **Sleeve: AISI 304 stainless steel**
- ※ **Motor mounts and base: cast iron G25**
- ※ **Shaft: AISI 431 stainless steel**
- ※ Coupling dimensions in compliance with NEMA standards.
- ※ Power cable included:
- ※ **3 m** for power ratings from 5.5 kW to 18.5 kW
- ※ **5 m** for powers from 22 to 37 kW.

APPLICATION LIMITS

- Liquid temperature up to **+30 °C**
- Depth of use up to **150 m** below water level
- Starts per hour: 20 at regular intervals
- Minimum cooling flow **8 cm/s**
- Continuous running duty **S1**

PERFORMANCE DATA

50 Hz

※ Three-phase versions - 400 V / 50 Hz

TYPE	Rated power		Axial load	Revolutions	Starting current	Yield	Power factor	Rated torque	Starting torque	h2	Weight
	P ₂										
Three-phase	kW	HP	N	min ⁻¹	Current nominal	η	Cos φ	Nm	Torque rated	mm	kg
6PSR / 7.5	5.5	7.5	20000	2850	5.1	78%	0.85	19	1.7	620	53.0
6PSR / 10	7.5	10		2855	5.1	79%	0.85	25	1.7	670	58.0
6PSR / 12.5	9.2	12.5		2860	4.9	80%	0.84	31	1.7	700	62.0
6PSR / 15	11	15		2865	5	81%	0.85	37	1.8	750	68.0
6PSR / 17.5	13	17.5		2860	5.1	81.5%	0.85	43	1.7	780	71.0
6PSR / 20	15	20		2865	4.8	83%	0.86	49	1.6	840	78.0
6PSR / 25	18.5	25		2840	5	82%	0.85	61	1.7	890	84.0
6PSR / 30	22	30	28000	2860	5.2	82.5%	0.86	74	1.6	975	94.0
6PSR / 35	26	35		2860	5.2	83.5%	0.85	87	1.6	1075	104.0
6PSR / 40	30	40		2860	5.2	83.5%	0.86	103	1.6	1215	122.0
6PSR / 50	37	50		2860	5.3	83.5%	0.86	125	1.7	1295	130.0

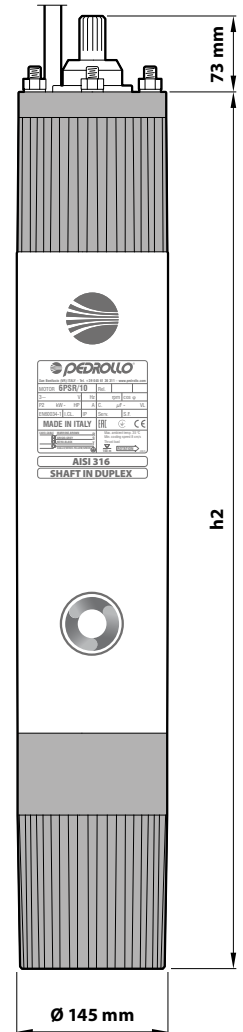

ABSORPTION

TYPE	VOLTAGE
Three-phase	400 V
6PSR / 7.5	13.0 A
6PSR / 10	16.0 A
6PSR / 12.5	20.0 A
6PSR / 15	23.0 A
6PSR / 17.5	27.5 A
6PSR / 20	30.0 A
6PSR / 25	38.0 A
6PSR / 30	45.0 A
6PSR / 35	53.0 A
6PSR / 40	60.5 A
6PSR / 50	75.5 A

-  Clean water
-  Domestic use
-  Civil use



TOP MULTI 1



TOP MULTI 2-3-4-5

PERFORMANCE RANGE

- Flow rate up to **120 l/min** (7.2 m³/h)
- Head up to **52 m**

INSTALLATION AND USE

TOPMULTI® pumps are designed to transfer **clean water** free from abrasive particles and liquids that will not damage the pump's components. Efficient and reliable, they are ideal for domestic applications involving tanks, reservoirs, and deep wells. They are also perfect for collecting rainwater from water tanks (rain barrels) for manual watering or irrigation systems.

APPLICATION LIMITS

- Maximum operating depth below water level:
 - up to **3 m** for TOP MULTI 1
 - up to **10 m** for TOP MULTI 2-3-4-5 (with an appropriately sized power cable)
- Liquid temperature up to **+40 °C**
- Draining capability:
 - up to **25 mm** from the bottom for TOP MULTI 1
 - up to **35 mm** from the bottom for TOP MULTI 2-3-4-5

INCLUDES

- ✳ Power cable length **10 m**
- ✳ Float switch
- ✳ Anti-vibration feet
- ✳ Hose connector **Ø 35 mm**
- ✳ Sleeve with clapet valve (for TOP MULTI 2-3-4-5)



PATENTS - TRADE MARKS - MODELS

- Registered Community Model No. 000885587 for TOP MULTI 2-3-4-5
- TOP MULTI® Registered trademark No. 0001334477

AVAILABLE UPON REQUEST

- ✳ Different voltage requirements 60 Hz frequency

CURVES AND PERFORMANCE DATA

50 Hz

TOP MULTI 1 - 2 - 4

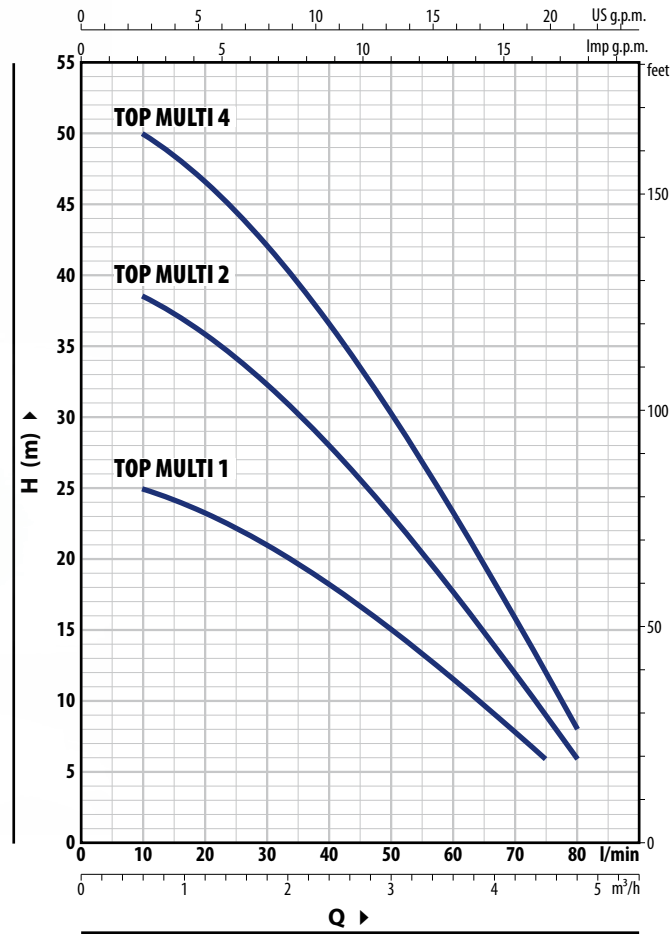

TOP MULTI 3 - 5



TOP MULTI 1 - 2 - 4

TYPE	POWER (P ₂)		Q	Flow rate											
	kW	HP		m ³ /h	0	0.6	1.2	1.8	2.4	3.0	3.6	4.2	4.5	4.8	
Single-phase			l/min	0	10	20	30	40	50	60	70	75	80		
TOP MULTI 1	0.37	0.50	H metres	26	25	23.3	21	18.3	15	11.6	8	6			
TOP MULTI 2	0.55	0.75		40	38.5	36	32.5	28	23	17.7	12	9	6		
TOP MULTI 4	0.75	1		52	50	46.5	42	36.5	30.5	23.3	15.8	12	8		

TOP MULTI 3 - 5

TYPE	POWER (P ₂)		Q	Flow rate													
	kW	HP		m ³ /h	0	0.6	1.2	1.8	2.4	3.0	3.6	4.2	4.8	5.4	6.0	6.6	7.2
Single-phase			l/min	0	10	20	30	40	50	60	70	80	90	100	110	120	
TOP MULTI 3	0.55	0.75	H metres	30.5	30	29	27.5	26	24.3	22.2	19.8	17.2	14.4	11.3	8	4.5	
TOP MULTI 5	0.75	1		41	40	38.5	37	35	32.5	29.5	26.5	23	19.2	15	10.7	6	

Q = Flow rate H = Total manometric head

Performance curves comply with EN ISO 9906 Grade 3B tolerance limits.

ABSORPTION

TYPE	VOLTAGE
Single-phase	230 V
TOP MULTI 1	2.0 A
TOP MULTI 2	3.4 A
TOP MULTI 3	3.6 A
TOP MULTI 4	3.9 A
TOP MULTI 5	3.9 A

DIMENSIONS AND WEIGHT

TOP MULTI 1

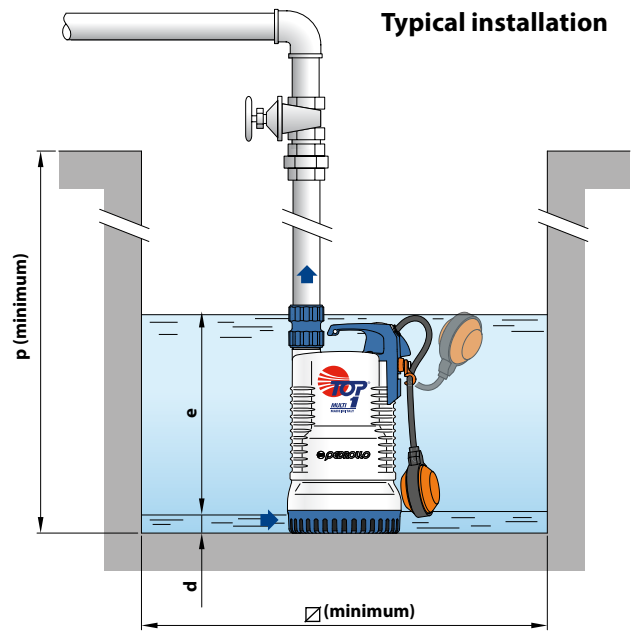
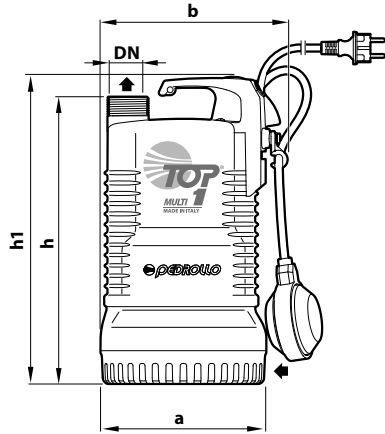

TOP MULTI 2-3-4-5

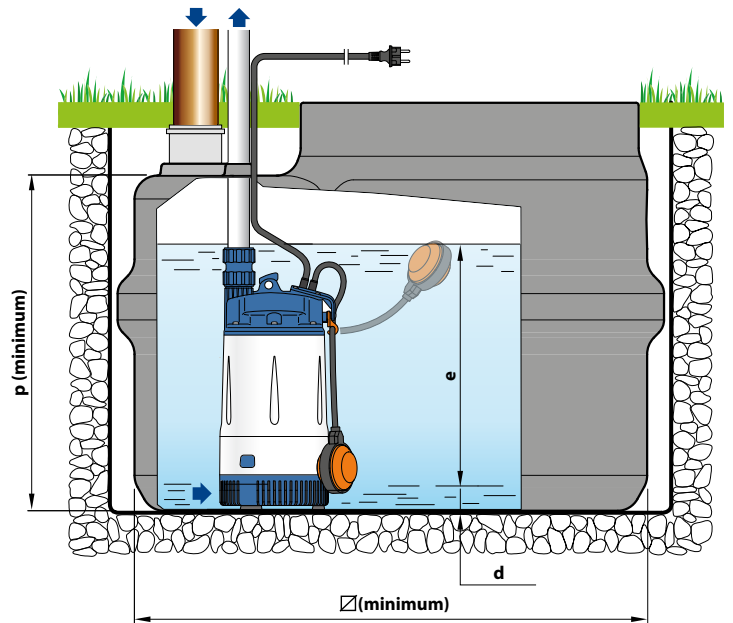
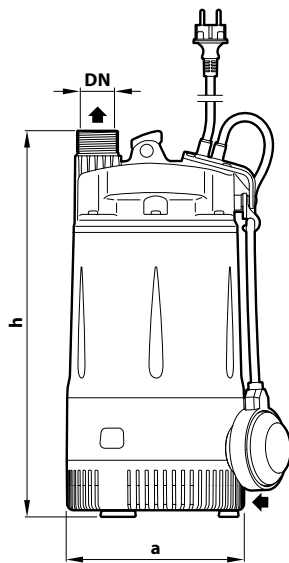



TYPE	PORT DN	NO. STAGES	DIMENSIONS mm								kg
			a	b	h	h1	d	e	p	∅	
TOP MULTI 1	1 1/4"	2	170	192	295	315	25	adjustable	350	350	6.9
TOP MULTI 2		3	178	-	380	-	35		500	500	9.3
TOP MULTI 3		4			415			10.4			
TOP MULTI 4		10.5									
TOP MULTI 5		10.5									

PALLET CAPACITY

TYPE	NO. OF PUMPS
TOP MULTI 1	60
TOP MULTI 2	60
TOP MULTI 3	60
TOP MULTI 4	60
TOP MULTI 5	60

TOP MULTI 1

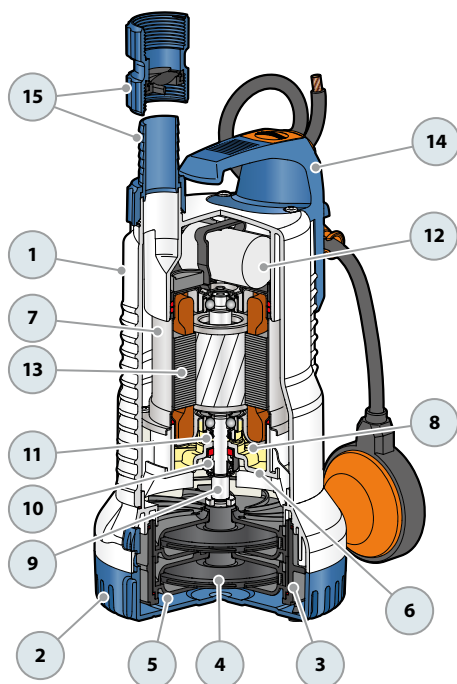

MATERIALS AND COMPONENTS

1 Pump body	Technopolymer
2 Suction filter	Technopolymer
3 Containment stages	Technopolymer
4 Impellers	Noryl™
5 Diffusers and stage boxes	Noryl™
6 Diffuser vanes	Technopolymer
7 Motor sleeve	Stainless steel AISI 304
8 Motor cover	Stainless steel AISI 304
9 Motor shaft	Stainless steel AISI 431
10 Mechanical seal	STA-12R Ceramic/Graphite/NBR
11 Shaft seal	Ø 12 x Ø 19 x H 5 mm
12 Capacitor	
13 Electric motor	
14 Handle group Including: - Float switch - Power cable with Schuko plug	
15 Ferrule and hose nozzle	
Sleeve With built-in clapet valve	



TOP MULTI 2-3-4-5

MATERIALS AND COMPONENTS

1 Delivery port	Technopolymer
2 Pump body	Technopolymer
3 Suction filter	Technopolymer
4 Diffuser vanes	Technopolymer
5 Motor sleeve	Stainless steel AISI 304
6 Impellers	Noryl™
7 Diffusers and stage boxes	Noryl™
8 Motor shaft	Stainless steel AISI 431
9 Double mechanical seal STA-13R Motor side Ceramic/Graphite/NBR STA-13R SIC Pump side SIC/Graphite/NBR	
10 Capacitor	
11 Electric motor	
12 Power cable with Schuko plug	
13 Float switch	
14 Ferrule and hose nozzle	
Sleeve With built-in clapet valve	
15 Anti-vibration feet	

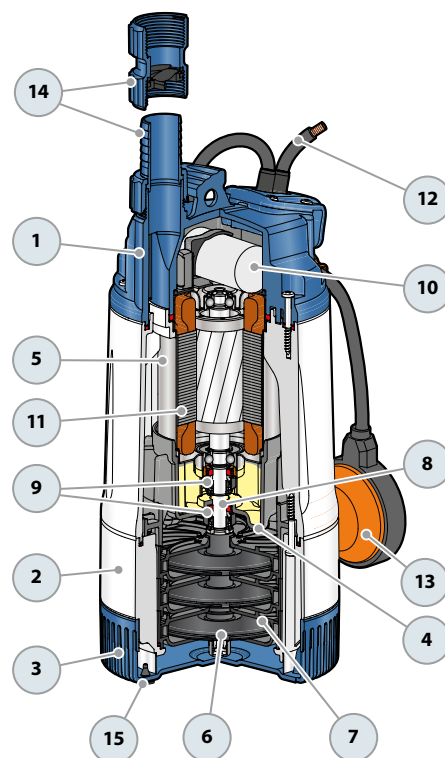

TOP MULTI-EVO Multi-stage submersible pumps

-  Clean water
-  Domestic use
-  Civil use



TOP MULTI 1 - EVO



TOP MULTI 2-3-4-5 - EVO

PERFORMANCE RANGE

- Flow rate up to **120 l/min** (7.2 m³/h)
- Head up to **52 m**

INSTALLATION AND USE

TOP MULTI-EVO pumps are designed to transfer **clean water** free from abrasive particles and liquids that will not damage the pump's components. Efficient and reliable, they are ideal for domestic applications involving tanks, reservoirs, and deep wells. They are also perfect for collecting rainwater from water tanks (rain barrels) for manual watering or irrigation systems.

APPLICATION LIMITS

- Maximum operating depth below water level:
 - up to **3 m** for TOP MULTI 1-EVO
 - up to **10 m** for TOP MULTI 2-3-4-5 EVO (with an appropriately sized power cable)
- Liquid temperature up to **+40 °C**
- Draining capability:
 - up to **25 mm** from the bottom for TOP MULTI 1-EVO
 - up to **35 mm** from the bottom for TOP MULTI 2-3-4-5 EVO
- Manometric suction head up to **7 m**

PATENTS - TRADE MARKS - MODELS

- TOP MULTI® Registered trademark No. 0001334477

INCLUDES

- ✳ **10 m** power cable
- ✳ Float switch
- ✳ Hose connector **Ø 35 mm**
- ✳ Complete sleeve with clapet valve

AVAILABLE UPON REQUEST

- ✳ Different voltage requirements 60 Hz frequency
- ✳ **KGE - Floating suction kit**



The KGE kit enables suction about 10 cm below the water surface, avoiding floating debris and sediment, thereby protecting the pump from damage.

Includes:

- 30 mm PVC spiral hose 1.5 metres long
- stainless steel suction filter
- spherical polyethylene float
- hose fittings Ø 30 mm

CURVES AND PERFORMANCE DATA

50 Hz

TOP MULTI 1-2-4 EVO

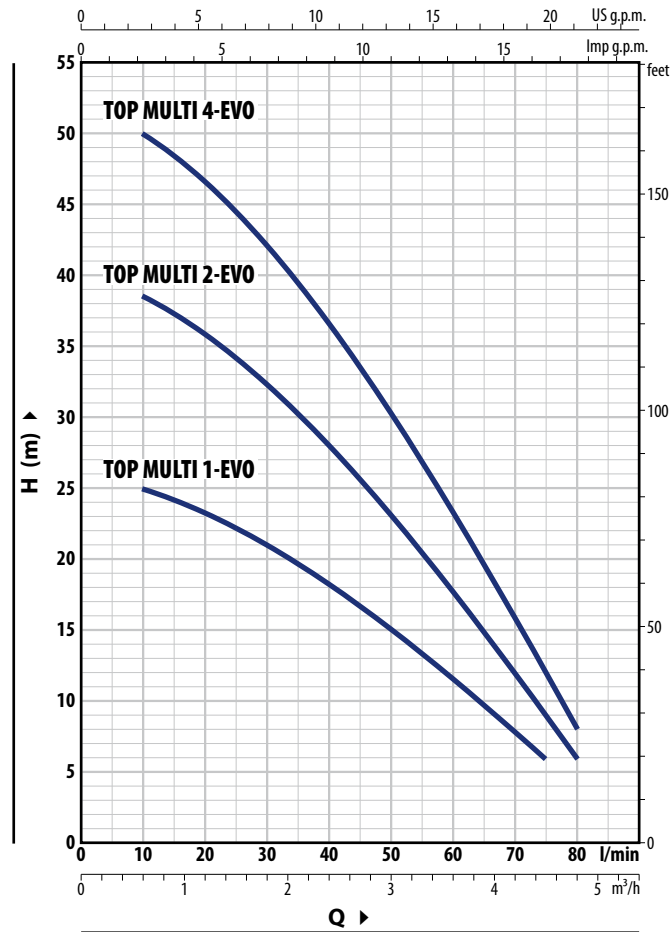

TOP MULTI 3-5 EVO

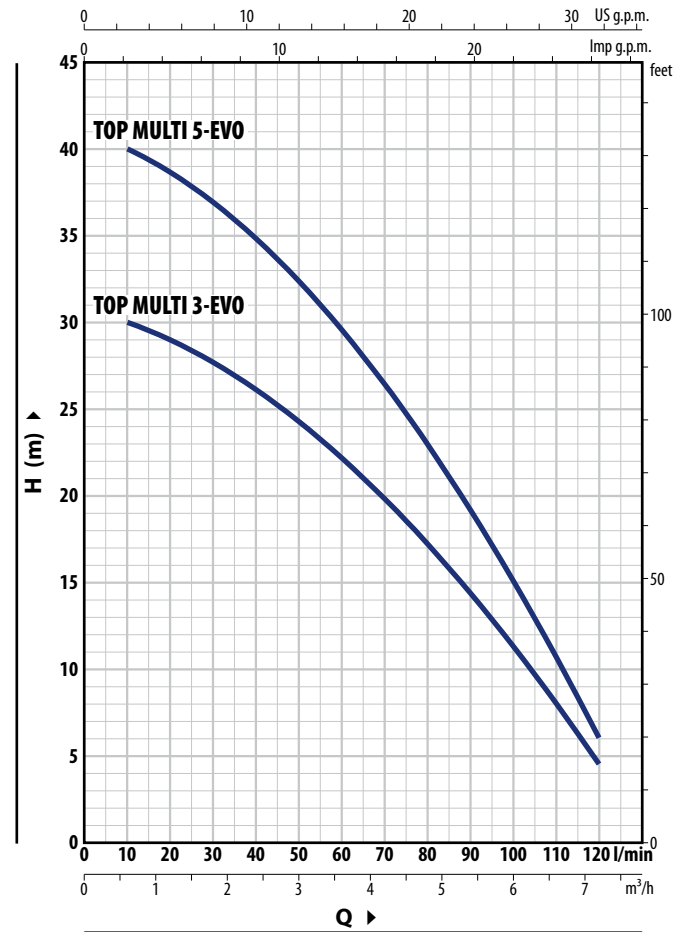

TOP MULTI 1-2-4 EVO

TYPE	POWER (P ₂)		Q	Flow rate											
	kW	HP		0	0.6	1.2	1.8	2.4	3.0	3.6	4.2	4.5	4.8		
Single-phase				0	10	20	30	40	50	60	70	75	80		
TOP MULTI 1-EVO	0.37	0.50	H metres	26	25	23.3	21	18.3	15	11.6	8	6			
TOP MULTI 2-EVO	0.55	0.75		40	38.5	36	32.5	28	23	17.7	12	9	6		
TOP MULTI 4-EVO	0.75	1		52	50	46.5	42	36.5	30.5	23.3	15.8	12	8		

TOP MULTI 3-5 EVO

TYPE	POWER (P ₂)		Q	Flow rate													
	kW	HP		0	0.6	1.2	1.8	2.4	3.0	3.6	4.2	4.8	5.4	6.0	6.6	7.2	
Single-phase				0	10	20	30	40	50	60	70	80	90	100	110	120	
TOP MULTI 3-EVO	0.55	0.75	H metres	30.5	30	29	27.5	26	24.3	22.2	19.8	17.2	14.4	11.3	8	4.5	
TOP MULTI 5-EVO	0.75	1		41	40	38.5	37	35	32.5	29.5	26.5	23	19.2	15	10.7	6	

Q = Flow rate H = Total manometric head

Performance curves comply with EN ISO 9906 Grade 3B tolerance limits.

ABSORPTION

TYPE	VOLTAGE
Single-phase	230 V
TOP MULTI 1-EVO	2.0 A
TOP MULTI 2-EVO	3.4 A
TOP MULTI 3-EVO	3.6 A
TOP MULTI 4-EVO	3.9 A
TOP MULTI 5-EVO	3.9 A

INSTALLATION EXAMPLES

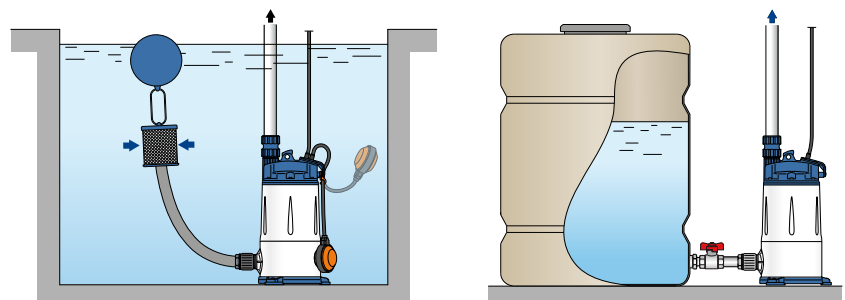

DIMENSIONS AND WEIGHT

TOP MULTI 1 EVO

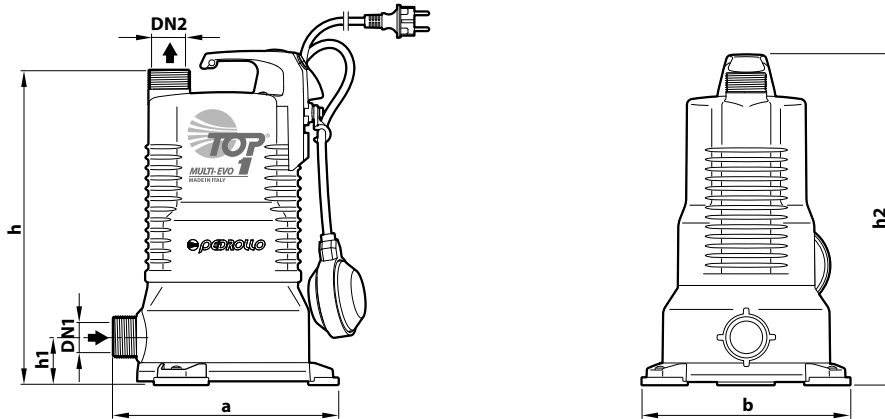

TOP MULTI 2-3-4-5 EVO

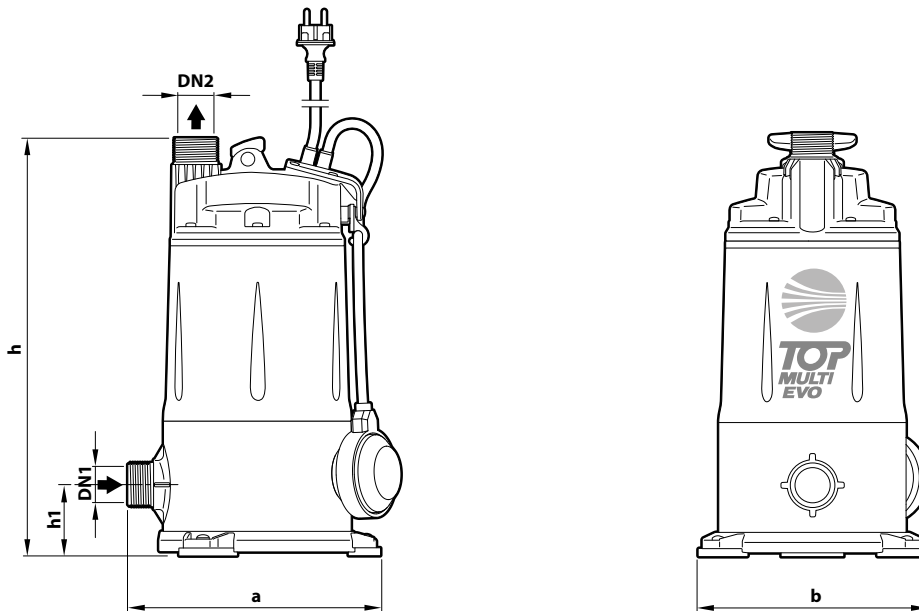



TYPE	PORTS		NO. STAGES	DIMENSIONS mm					kg
	DN1	DN2		a	b	h	h1	h2	
TOP MULTI 1-EVO	1 1/4"	1 1/4"	2	227	210	317	49	337	7.1
TOP MULTI 2-EVO			3	239	216	394	68	-	9.9
TOP MULTI 3-EVO			3			9.9			
TOP MULTI 4-EVO			4			10.4			
TOP MULTI 5-EVO			4			10.4			

PALLET CAPACITY

TYPE	NO. OF PUMPS
TOP MULTI 1-EVO	45
TOP MULTI 2-EVO	45
TOP MULTI 3-EVO	45
TOP MULTI 4-EVO	45
TOP MULTI 5-EVO	45

TOP MULTI 1 EVO

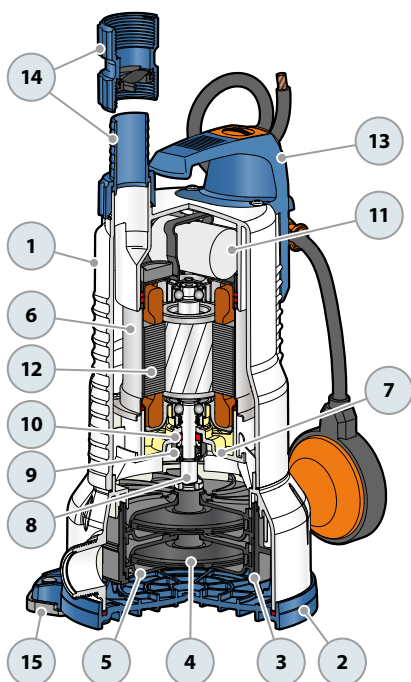

MATERIALS AND COMPONENTS

1 Pump body	Technopolymer
2 Base	Technopolymer
3 Containment stages	Technopolymer
4 Impellers	Noryl™
5 Diffusers and stage boxes	Noryl™
6 Motor sleeve	Stainless steel AISI 304
7 Motor cover	Stainless steel AISI 304
8 Motor shaft	Stainless steel AISI 431
9 Mechanical seal	STA-12R Ceramic/Graphite/NBR
10 Shaft seal	Ø 12 x Ø 19 x H 5 mm
11 Capacitor	
12 Electric motor	
13 Handle group	Including: - Float switch - Power cable with Schuko plug
14 Ferrule and hose nozzle	
Sleeve With built-in clapet valve	
15 Anti-vibration feet	



TOP MULTI 2-3-4-5 EVO

MATERIALS AND COMPONENTS

1 Delivery port	Technopolymer
2 Suction body	Technopolymer
3 Base	Technopolymer
4 Diffuser vanes	Technopolymer
5 Motor sleeve	Stainless steel AISI 304
6 Impellers	Noryl™
7 Diffusers and stage boxes	Noryl™
8 Motor shaft	Stainless steel AISI 431
9 Double mechanical seal	STA-13R Motor side Ceramic/Graphite/NBR STA-13R SIC Pump side SIC/Graphite/NBR
10 Capacitor	
11 Electric motor	
12 Power cable with Schuko plug	
13 Float switch	
14 Ferrule and hose nozzle	
Sleeve With built-in clapet valve	
15 Anti-vibration feet	

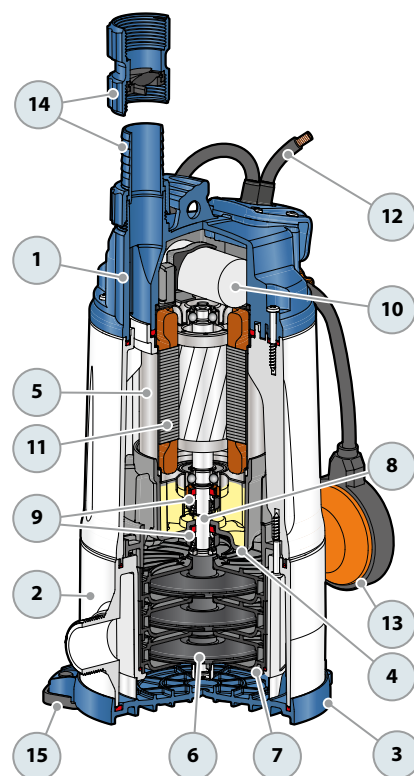

-  Clean water
-  Domestic use
-  Civil use

※ AUTOMATIC START & STOP

The integrated electronic device allows the pump to be started or stopped automatically by opening or closing the tap.



PERFORMANCE RANGE

- Flow rate up to **120 l/min** (7.2 m³/h)
- Head up to **52 m**
- Restart pressure:
 - **1.5 bar** for TOP MULTI-TECH 2-3-5
 - **2.5 bar** for TOP MULTI-TECH 4

INSTALLATION AND USE

TOP-MULTI-TECH pumps are designed to transfer **clean water** free from abrasive particles and liquids that will not damage the pump's components. Efficient and reliable, they are ideal for domestic applications involving tanks, reservoirs, and deep wells. They are also perfect for collecting rainwater from water tanks (rain barrels) for manual watering or irrigation systems.

ELECTRONIC DEVICE

TOP MULTI-TECH pumps feature an internal electronic device that activates the pump if system pressure (such as when a tap opens) falls below **1.5 bar** (or **2.5 bar** for TOP MULTI-TECH 4) and deactivates it when flow declines to less than 3 l/min.

- ※ Protects the pump:
 - **against dry running;**
 - **to prevent blockages, the electronic device automatically runs the pump for 10 seconds every 48 hours after extended periods of inactivity.**

APPLICATION LIMITS

- Maximum operating depth below water level up to **5 m**
- Maximum height between pump and user: **10 m**
- Liquid temperature up to **+40 °C**
- Draining capability up to **35 mm** from the bottom

INCLUDES

- ※ **10 m** power cable
- ※ Threaded fitting 1¼"
- ※ Hose connector **Ø 35 mm**

PATENTS - TRADE MARKS - MODELS

- Patent No. EP2990653
- TOP MULTI® Registered trademark No. 0001334477

CURVES AND PERFORMANCE DATA

50 Hz

TOP MULTI-TECH 2-4

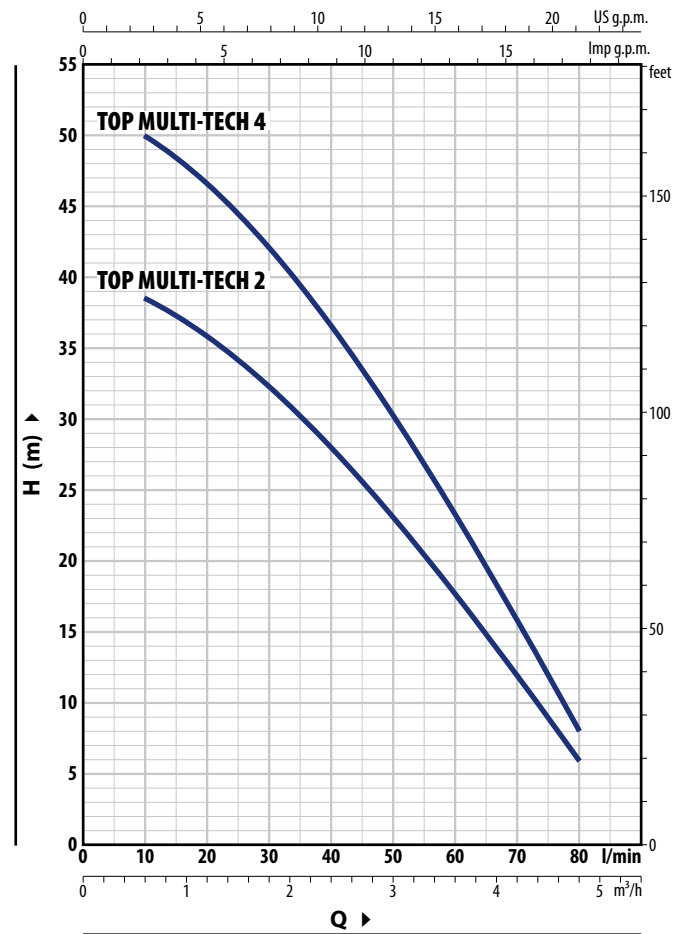

TOP MULTI-TECH 3-5

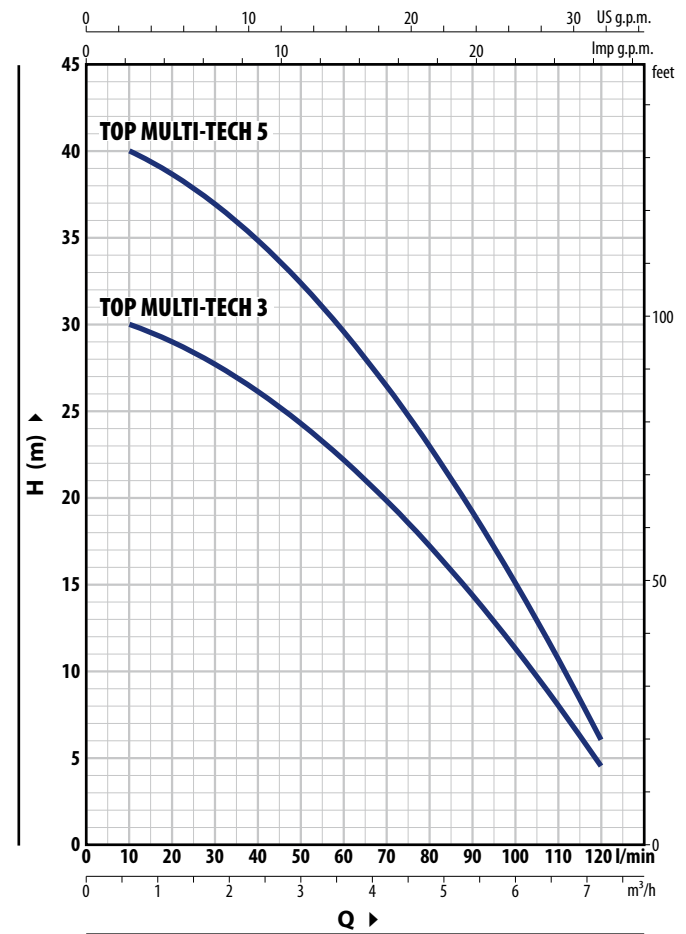

TOP MULTI-TECH 2-4

TYPE	POWER (P ₂)		Q	Flow rate											
	kW	HP		m ³ /h	0	0.6	1.2	1.8	2.4	3	3.6	4.2	4.5	4.8	
Single-phase			l/min	0	10	20	30	40	50	60	70	75	80		
TOP MULTI-TECH 2	0.55	0.75	H metres	40	38.5	36	32.5	28	23	17.7	12	9	6		
TOP MULTI-TECH 4	0.75	1		52	50	46.5	42	36.5	30.5	23.3	15.8	12	8		

TOP MULTI-TECH 3-5

TYPE	POWER (P ₂)		Q	Flow rate														
	kW	HP		m ³ /h	0	0.6	1.2	1.8	2.4	3	3.6	4.2	4.5	4.8	5.4	6	6.6	7.2
Single-phase			l/min	0	10	20	30	40	50	60	70	75	80	90	100	110	120	
TOP MULTI-TECH 3	0.55	0.75	H metres	30.5	30	29	27.5	26	24.3	22.2	19.8	18.5	17.2	14.4	11.3	8	4.5	
TOP MULTI-TECH 5	0.75	1		41	40	38.5	37	35	32.5	29.5	26.5	24.7	23	19.2	15	10.7	6	

Q = Flow rate H = Total manometric head

Performance curves comply with EN ISO 9906 Grade 3B tolerance limits.

ABSORPTION

TYPE	VOLTAGE
Single-phase	230 V
TOP MULTI-TECH 2	3.4 A
TOP MULTI-TECH 3	3.6 A
TOP MULTI-TECH 4	3.9 A
TOP MULTI-TECH 5	3.9 A

DIMENSIONS AND WEIGHT

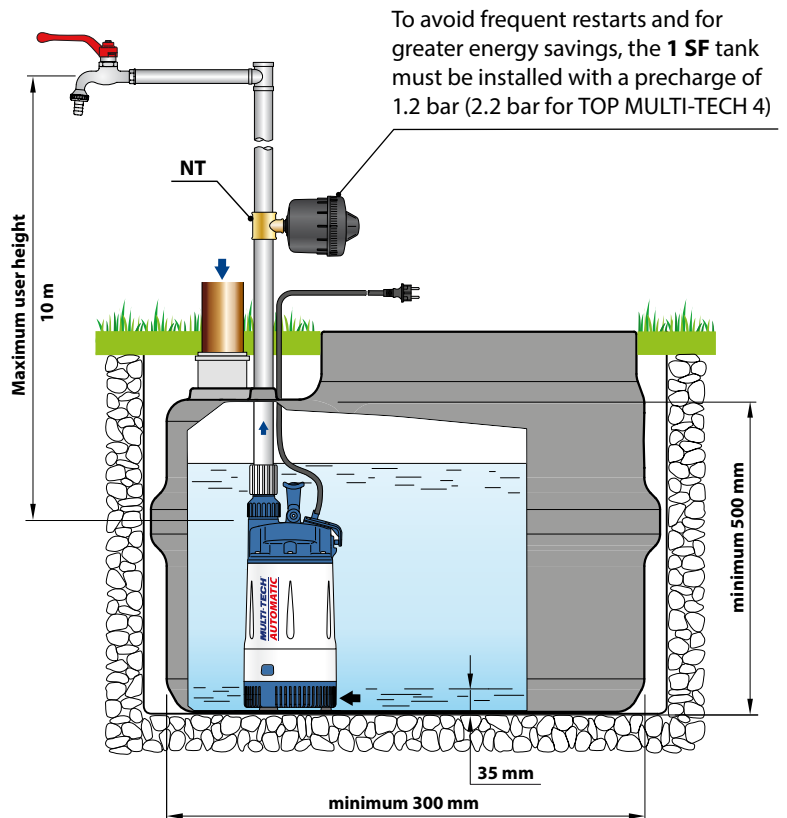
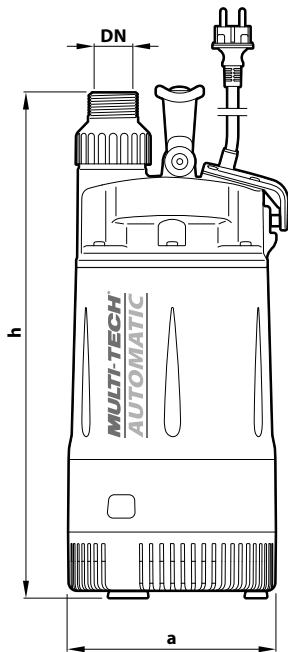

TYPE	PORT DN	DIMENSIONS mm		kg
		a	h	
TOP MULTI-TECH 2	1 1/4"	178	428	9.5
TOP MULTI-TECH 3			463	10.5
TOP MULTI-TECH 4				
TOP MULTI-TECH 5				



PALLET CAPACITY

TYPE	NO. OF PUMPS
TOP MULTI-TECH 2	60
TOP MULTI-TECH 3	60
TOP MULTI-TECH 4	40
TOP MULTI-TECH 5	40

Typical installation



ACCESSORIES (CAN BE ORDERED SEPARATELY)

TYPE	Code	FITTING	CAPACITY	PRECHARGE	MAXIMUM WORKING PRESSURE
※ Tank 1 SF 	50057005	1/2" (male)	1 litre	1.2 bar	10 bar
3-way fitting NT 1.25 	500160001	1 1/4" - 1/4" - 1/2" gas	-	-	-

MATERIALS AND COMPONENTS

1	Delivery port	Technopolymer
2	Pump body	Technopolymer
3	Suction filter	Technopolymer
4	Diffuser vanes	Technopolymer
5	Motor sleeve	Stainless steel AISI 304
6	Impellers	Noryl™
7	Diffusers and stage boxes	Noryl™
8	Motor shaft	Stainless steel AISI 431
9	Electronic device	

10 Double mechanical seal with interposed oil chamber

Seal	Shaft	Location	Materials
STA-13R	Ø 13 mm	Motor side	Ceramic / Graphite /NBR
STA-13R SIC	Ø 13 mm	Pump side	Silicon carbide / Graphite /NBR

11 Capacitor

12 Electric motor

TOP MULTI-TECH: single-phase 230 V - 50 Hz with winding integrated thermal motor protection.

- Continuous running duty S1
- Insulation: Class F
- Protection rating: IP X8

13 Power cord

Type 'H07 RN-F' with Schuko plug

※ Standard length 10 metres

14 Threaded connection 1¼"



15 Ferrule and hose connector Ø 35 mm



16 Anti-vibration feet

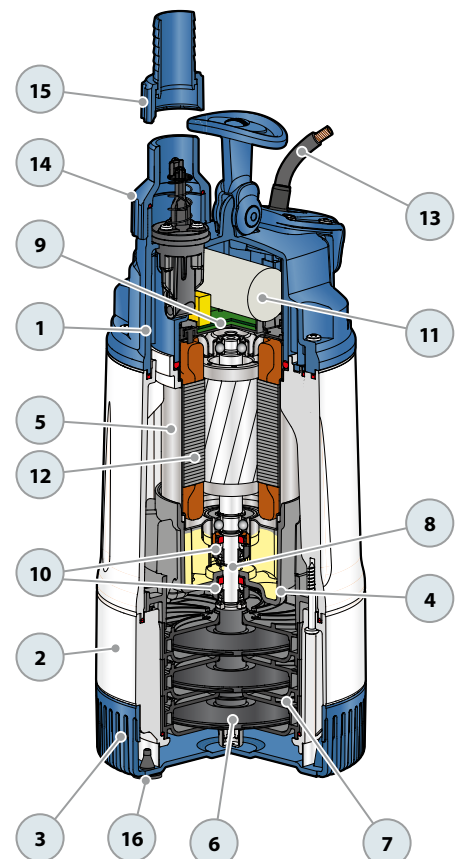

TOP MULTI-EVOTECH

Automatic submersible pumps

-  Clean water
-  Domestic use
-  Civil use

※ AUTOMATIC START & STOP

The integrated electronic device automatically starts or stops the pump when the tap is opened or closed.



PERFORMANCE RANGE

- Flow rate up to **120 l/min** (7.2 m³/h)
- Head up to **52 m**
- Restart pressure:
 - **1.5 bar** for TOP MULTI-EVOTECH 2-3-5
 - **2.5 bar** for TOP MULTI-EVOTECH 4

INSTALLATION AND USE

TOP MULTI-EVOTECH pumps are designed to transfer **clean water** free from abrasive particles and liquids that will not damage the pump's components. Efficient and reliable, they are ideal for domestic applications involving tanks, reservoirs, and deep wells. They are also perfect for collecting rainwater from water tanks (rain barrels) for manual watering or irrigation systems.

ELECTRONIC DEVICE

TOP MULTI-EVOTECH pumps feature an internal electronic device that activates the pump if system pressure (such as when a tap opens) falls below **1.5 bar** (or **2.5 bar** for TOP MULTI-EVOTECH 4) and deactivates it when flow declines to less than 3 l/min.

- ※ Protects the pump:
 - **against dry running;**
 - **to prevent blockages, the electronic device automatically runs the pump for 10 seconds every 48 hours after extended periods of inactivity.**

APPLICATION LIMITS

- Maximum operating depth below water level up to **5 m**
- Maximum height between pump and utility **10 m**
- Liquid temperature up to **+40 °C**
- Draining capability up to **35 mm** from the bottom

INCLUDES

- ※ **10 m** power cable
- ※ Threaded connection 1¼" (delivery)
- ※ Hose connector Ø 35 mm

AVAILABLE UPON REQUEST

- ※ Different voltage requirements 60 Hz frequency
- ※ **KGE - Floating suction kit**



The KGE kit enables suction about 10 cm below the water surface, avoiding floating debris and sediment, thereby protecting the pump from damage.

- Includes:
- 30 mm PVC spiral hose 1.5 metres long
 - stainless steel suction filter
 - spherical polyethylene float
 - hose fittings Ø 30 mm

PATENTS - TRADE MARKS - MODELS

- Patent No. EP2990653
- TOP MULTI® Registered trademark No. 0001334477

CURVES AND PERFORMANCE DATA

50 Hz

TOP MULTI-EVOTECH 2-4

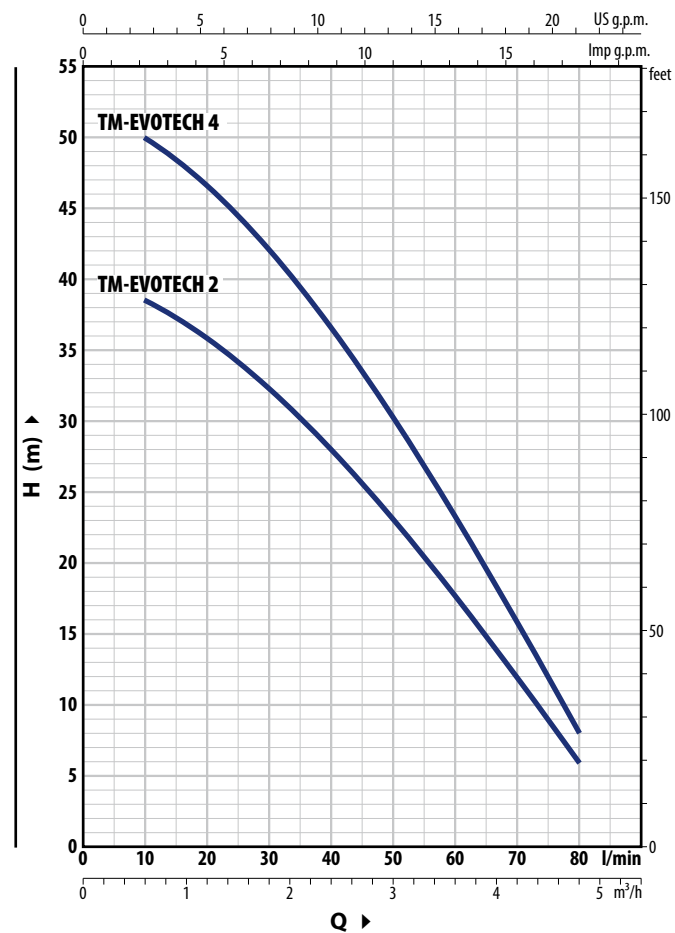

TOP MULTI-EVOTECH 3-5

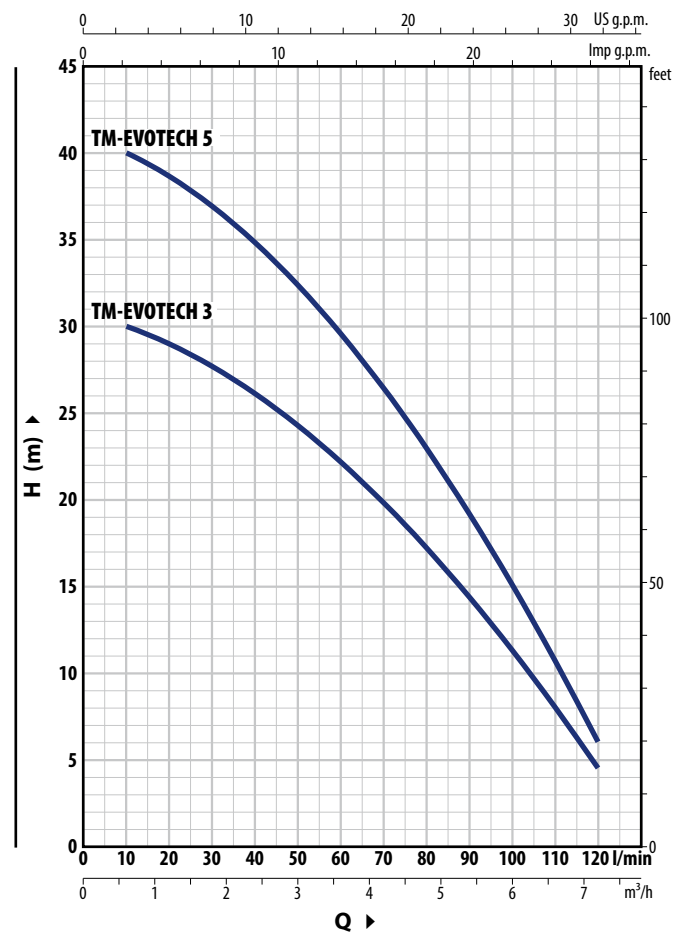

TOP MULTI-EVOTECH 2-4

TYPE	POWER (P ₂)		Q	Flow rate											
	kW	HP		m ³ /h	0	0.6	1.2	1.8	2.4	3	3.6	4.2	4.5	4.8	
Single-phase			l/min	0	10	20	30	40	50	60	70	75	80		
TOP MULTI-EVOTECH 2	0.55	0.75	H metres	40	38.5	36	32.5	28	23	17.7	12	9	6		
TOP MULTI-EVOTECH 4	0.75	1		52	50	46.5	42	36.5	30.5	23.3	15.8	12	8		

TOP MULTI-EVOTECH 3-5

TYPE	POWER (P ₂)		Q	Flow rate													
	kW	HP		m ³ /h	0	0.6	1.2	1.8	2.4	3	3.6	4.2	4.5	4.8	5.4	6	6.6
Single-phase			l/min	0	10	20	30	40	50	60	70	75	80	90	100	110	120
TOP MULTI-EVOTECH 3	0.55	0.75	H metres	30.5	30	29	27.5	26	24.3	22.2	19.8	18.5	17.2	14.4	11.3	8	4.5
TOP MULTI-EVOTECH 5	0.75	1		41	40	38.5	37	35	32.5	29.5	26.5	24.7	23	19.2	15	10.7	6

Q = Flow rate H = Total manometric head

Performance curves comply with EN ISO 9906 Grade 3B tolerance limits.

ABSORPTION

TYPE	VOLTAGE
Single-phase	230 V
TOP MULTI-EVOTECH 2	3.4 A
TOP MULTI-EVOTECH 3	3.6 A
TOP MULTI-EVOTECH 4	3.9 A
TOP MULTI-EVOTECH 5	3.9 A

DIMENSIONS AND WEIGHT

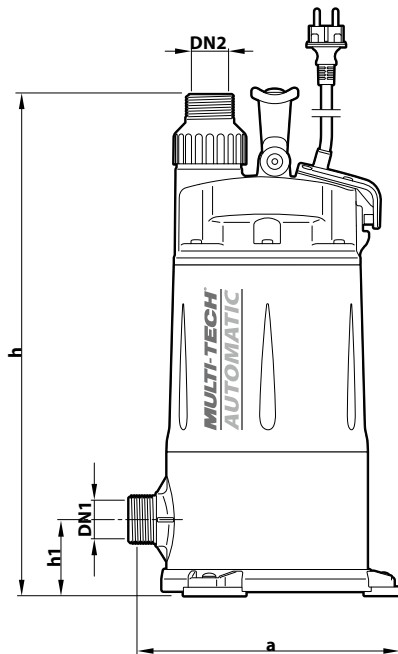

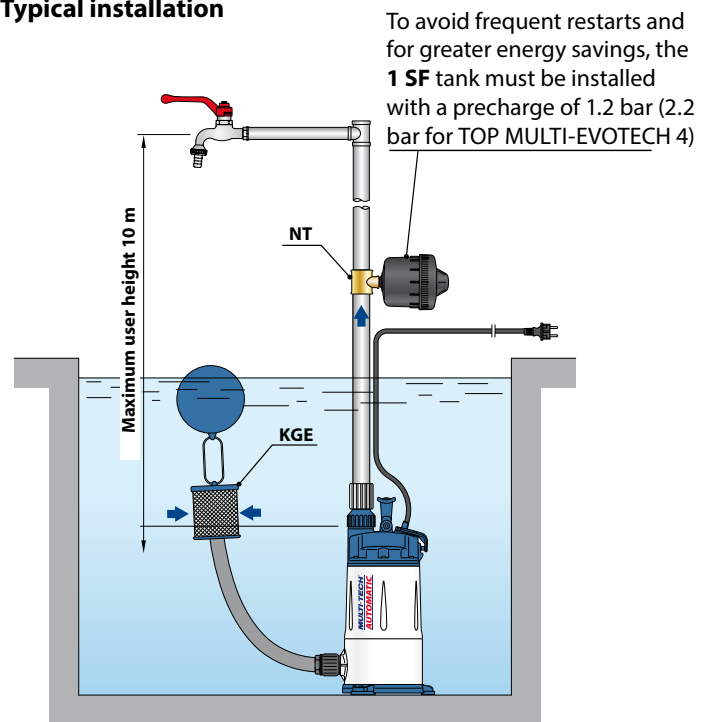

Typical installation



To avoid frequent restarts and for greater energy savings, the **1 SF** tank must be installed with a precharge of 1.2 bar (2.2 bar for TOP MULTI-EVOTECH 4)

TYPE	PORTS		NO. STAGES	DIMENSIONS mm			kg
	DN1	DN2		a	h	h1	
TOP MULTI-EVOTECH 2	1 1/4"	1 1/4"	3	239	442	68	9.9
TOP MULTI-EVOTECH 3			4		11.0		
TOP MULTI-EVOTECH 4			4		11.0		
TOP MULTI-EVOTECH 5			4		11.0		



ACCESSORIES (CAN BE ORDERED SEPARATELY)

TYPE	Code	FITTING	CAPACITY	PRECHARGE	MAXIMUM WORKING PRESSURE
※ Tank 1 SF 	50057005	1/2" (male)	1 litre	1.2 bar	10 bar
3-way fitting NT 1.25 	500160001	1 1/4" - 1 1/4" - 1/2" gas	-	-	-

PALLET CAPACITY

TYPE	NO. OF PUMPS
TOP MULTI-EVOTECH 2	45
TOP MULTI-EVOTECH 3	45
TOP MULTI-EVOTECH 4	45
TOP MULTI-EVOTECH 5	45

MATERIALS AND COMPONENTS

1	Delivery port	Technopolymer with ISO 228/1 threaded port		
2	Suction body	Technopolymer with ISO 228/1 threaded port		
3	Base	Technopolymer		
4	Diffuser vanes	Technopolymer		
5	Motor sleeve	Stainless steel AISI 304		
6	Impellers	Noryl™		
7	Diffusers and stage boxes	Noryl™		
8	Motor shaft	Stainless steel AISI 431		
9	ELECTRONIC DEVICE			
10	Double mechanical seal with interposed oil chamber			
	Seal	Shaft	Location	Materials
	STA-13R	Ø 13 mm	Motor side	Ceramic / Graphite /NBR
	STA-13R SIC	Ø 13 mm	Pump side	Silicon carbide / Graphite /NBR
11	Capacitor			
12	Electric motor			
	TOP MULTI-EVOTECH: single-phase 230 V - 50 Hz with winding integrated thermal motor protection.			
	– Continuous running duty S1			
	– Insulation: Class F			
	– Protection rating: IP X8			
13	Power cord			
	Type 'H07 RN-F' with Schuko plug			
	※ Standard length 10 metres			
14	Threaded connection 1¼"			
15	Ferrule and hose connector Ø 35 mm			
16	Anti-vibration feet			

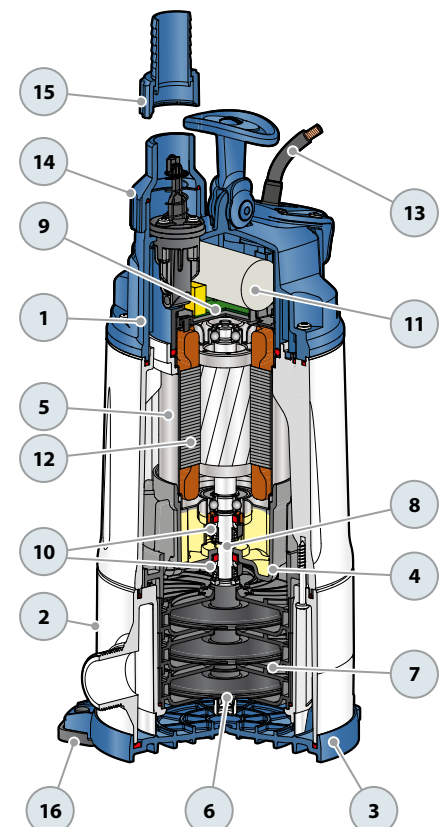

 Clean water

 Domestic use

 Civil use

 Agricultural use



PERFORMANCE RANGE

- Flow rate up to **180 l/min** (10.8 m³/h)
- Head up to **97 m**

INSTALLATION AND USE

A series of multi-impeller submersible pumps engineered for enhanced reliability, thanks to innovative patented solutions that prevent stalling even after prolonged periods of inactivity.

Highly efficient and reliable, these pumps are ideal for various applications, including water distribution in domestic, civil, and agricultural settings, particularly for water distribution in conjunction with pressure tanks, for irrigation, pressure boosting, and more.

APPLICATION LIMITS

- Liquid temperature up to **+40 °C**
- Maximum sand content **150 g/m³**
- Maximum operating depth below water level up to **20 m** (with an appropriately sized power cable)
- Vertical and horizontal operation

INCLUDES

- ✘ Float switch (exclusive to single-phase models)
- ✘ Power cable length **10 m**

AVAILABLE UPON REQUEST

- ✘ Pumps without float switch
- ✘ **20 m** or **30 m** power cables
- ✘ Different voltage requirements 60 Hz frequency
- ✘ **Support kit for horizontal operation**

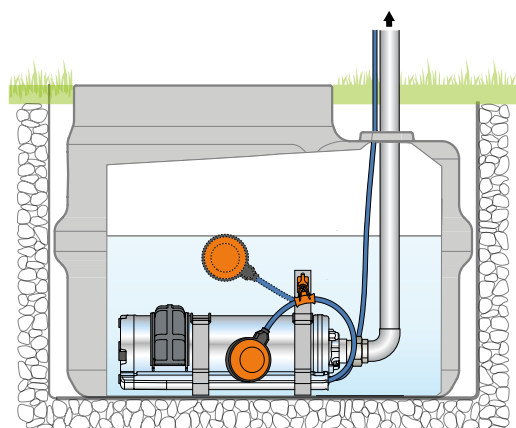

PATENTS - TRADE MARKS - MODELS

- Patent No. IT0001428923
- Patent No. EP2419642

CURVES AND PERFORMANCE DATA

50 Hz

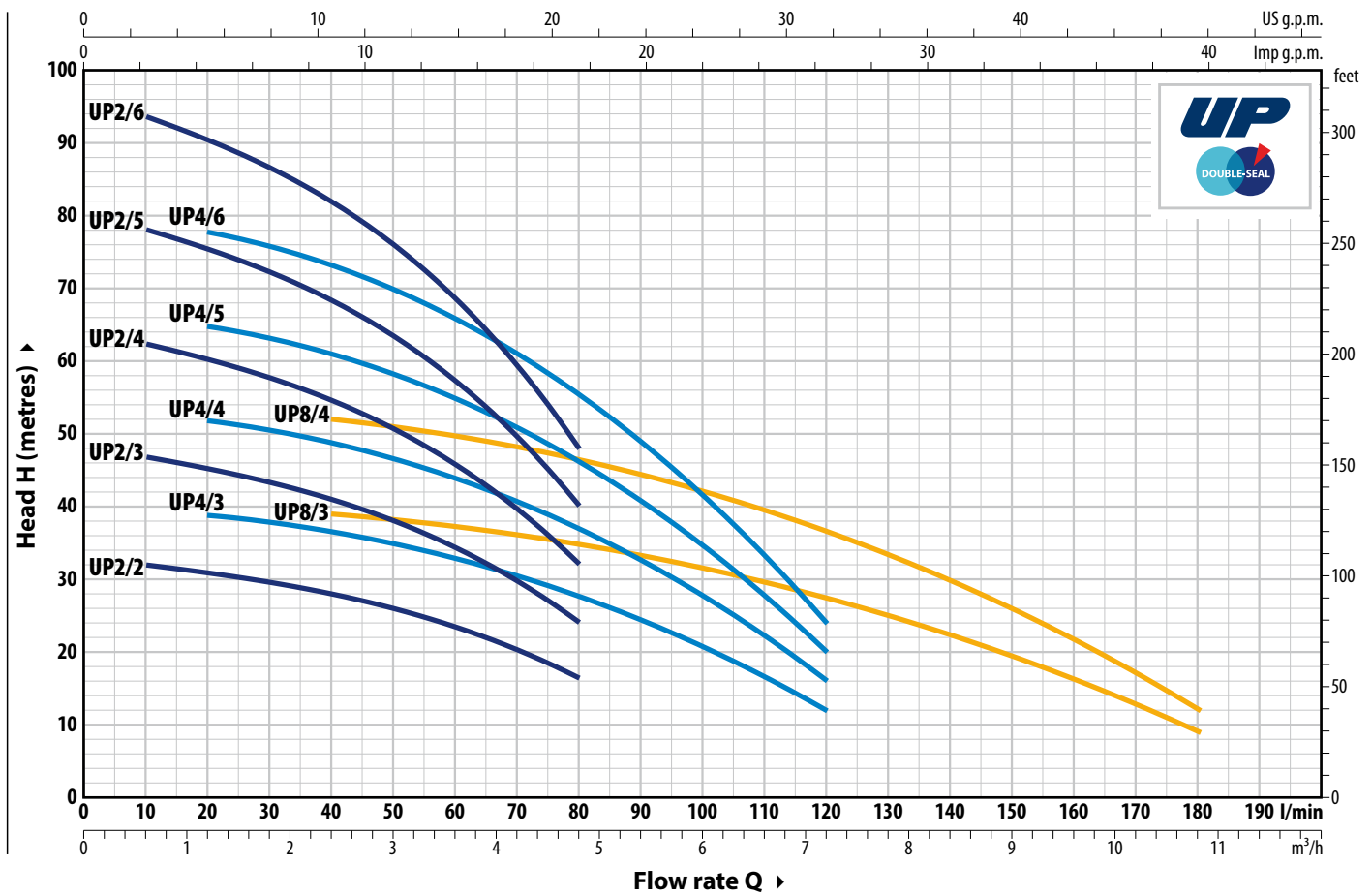

TYPE		POWER (P ₂)		Q m ³ /h l/min	H metres												
Single-phase	Three-phase	kW	HP		0	0.6	1.2	2.4	3.6	4.8	6.0	7.2	8.4	9.6	10.8		
UPm 2/2-GE	–	0.37	0.5	0	10	20	40	60	80	100	120	140	160	180			
UPm 2/3-GE	UP 2/3	0.55	0.75	33	32	31	28	23.5	16.4								
UPm 2/4-GE	UP 2/4	0.75	1	48.5	47	45	41	34.5	24								
UPm 2/5-GE	UP 2/5	1.1	1.5	64.5	62.5	60.5	54.5	46	32								
UPm 2/6-GE	UP 2/6	1.5	2	80	78	75	68.5	57	40								
UPm 4/3-GE	UP 4/3	0.55	0.75	97	94	90	82	68.5	48								
UPm 4/4-GE	UP 4/4	0.75	1	40	–	39	36.5	33	28	20.8	12						
UPm 4/5-GE	UP 4/5	1.1	1.5	53	–	52	49	44	37	28	16						
UPm 4/6-GE	UP 4/6	1.5	2	67	–	65	61	55	46.5	34.5	20						
UPm 8/3-GE	UP 8/3	1.1	1.5	80	–	78	73	66	55.5	41.5	24						
UPm 8/4-GE	UP 8/4	1.5	2	40.5	–	–	39	37.5	35	31.5	27.5	22.3	16.2	9			
				54	–	–	52	49.5	46.5	42	36.5	29.5	21.6	12			

Q = Flow rate H = Total manometric head

Performance curves comply with EN ISO 9906 Grade 3B tolerance limits.

➡ On request single-phase pumps without float switch

ABSORPTION

TYPE	VOLTAGE
Single-phase	230 V
UPm 2/2-GE	4.4 A
UPm 2/3-GE	5.4 A
UPm 2/4-GE	6.2 A
UPm 2/5-GE	7.6 A
UPm 2/6-GE	8.8 A
UPm 4/3-GE	5.0 A
UPm 4/4-GE	6.2 A
UPm 4/5-GE	7.2 A
UPm 4/6-GE	8.7 A
UPm 8/3-GE	6.8 A
UPm 8/4-GE	8.5 A

TYPE	VOLTAGE
Three-phase	400 V
UP 2/3	1.9 A
UP 2/4	2.3 A
UP 2/5	2.9 A
UP 2/6	3.3 A
UP 4/3	1.8 A
UP 4/4	2.2 A
UP 4/5	2.8 A
UP 4/6	3.2 A
UP 8/3	2.7 A
UP 8/4	3.3 A

DIMENSIONS AND WEIGHT

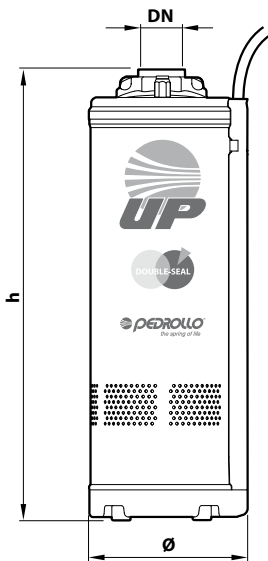

※ VERTICAL INSTALLATION

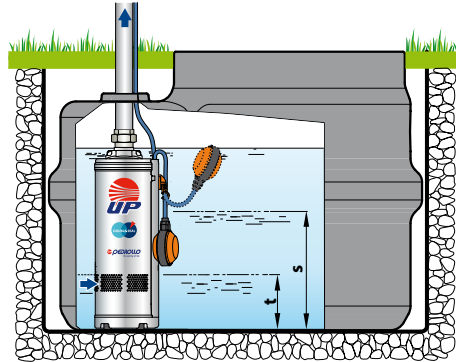

※ HORIZONTAL INSTALLATION

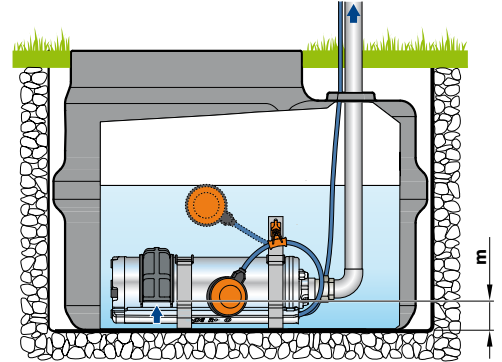

TYPE		PORT DN	DIMENSIONS mm		kg	
Single-phase	Three-phase		Ø	h	1~	3~
UPm 2/2-GE	-	1 1/4"	150	384	12.8	12.5
UPm 2/3-GE	UP 2/3			411	13.1	13.3
UPm 2/4-GE	UP 2/4			468	14.9	14.0
UPm 2/5-GE	UP 2/5			495	16.5	15.3
UPm 2/6-GE	UP 2/6			542	18.0	16.7
UPm 4/3-GE	UP 4/3			411	13.2	12.9
UPm 4/4-GE	UP 4/4			468	14.8	13.4
UPm 4/5-GE	UP 4/5			495	16.4	15.3
UPm 4/6-GE	UP 4/6			542	18.1	16.9
UPm 8/3-GE	UP 8/3			441	15.2	14.2
UPm 8/4-GE	UP 8/4			488	17.0	15.8

TYPE	LEVELS mm		
	s	t	m
UP 2/2 UP 2/3 UP 4/3	310		
UP 2/4 UP 2/5 UP 4/4 UP 4/5 UP 8/3	340	113	55
UP 2/6 UP 4/6 UP 8/4	360		

s = Minimum restart level
t = Draining capability
m = Minimum operating level

PALLET CAPACITY

TYPE		NO. OF PUMPS
Single-phase	Three-phase	
UPm 2/2-GE	-	30
UPm 2/3-GE	UP 2/3	30
UPm 2/4-GE	UP 2/4	30
UPm 2/5-GE	UP 2/5	25
UPm 2/6-GE	UP 2/6	25
UPm 4/3-GE	UP 4/3	30
UPm 4/4-GE	UP 4/4	30
UPm 4/5-GE	UP 4/5	25
UPm 4/6-GE	UP 4/6	25
UPm 8/3-GE	UP 8/3	30
UPm 8/4-GE	UP 8/4	30

MATERIALS AND COMPONENTS

1 Outer sleeve AISI 304 stainless steel with ISO 228/1 threaded delivery port

2 Internal motor jacket Stainless steel **AISI 304**

3 Impellers and diffusers Noryl™

4 Diaphragms Stainless steel **AISI 304**

5 Motor shaft Stainless steel **AISI 431**

6 Double mechanical seal with interposed oil chamber

Seal	Shaft	Location	Materials
STA-17	Ø 17 mm	Motor side	Ceramic / Graphite /NBR
ST1-16	Ø 16 mm	Pump side	Silicon carbide / Graphite / NBR

7 Capacitor

8 Electric motor

UPm: single-phase 230 V - 50 Hz with winding integrated thermal motor protection

UP: three-phase 400 V - 50 Hz

- Continuous running duty S1
 - Insulation: Class F
 - Protection rating: IP X8
-

9 Power cord

⇒ **DRINCABLE®** type
 approved for use in drinking water by **WRAS**
 according to BS 6920, approval no. 7513

※ Standard length 10 metres

10 Automatic vent valve

11 Anti-vibration feet

12 Float switch
 (exclusive to single-phase models)

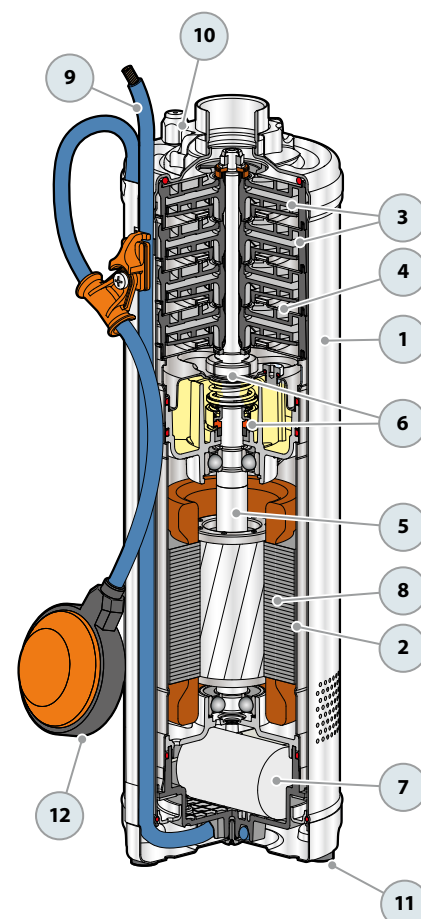

-  Clean water
-  Domestic use
-  Civil use
-  Agricultural use



※ Designed to transfer clean water in domestic, agricultural, and civil settings.
Optimal for tanks or reservoirs water supply and garden irrigation

PERFORMANCE RANGE

- Flow rate up to **160 l/min** (9.6 m³/h)
- Head up to **97 m**

AVAILABLE UPON REQUEST

- ※ Other power cable lengths available
- ※ Different voltage requirements 60 Hz frequency

INSTALLATION AND USE

Designed for enhanced reliability with patented solutions to prevent stalling during extended periods of inactivity. Superb for various applications including domestic, civil, and agricultural sectors, water distribution with pressure tanks, irrigation, and enhancing water pressure.

PATENTS - TRADE MARKS - MODELS

- Patent No. IT0001428923

INCLUDES

- ※ Float switch (exclusive to single-phase models)
- ※ Power cable length **10 m**

APPLICATION LIMITS

- Liquid temperature up to **+40 °C**
- Maximum sand content **150 g/m³**
- Maximum operating depth below water level up to **20 m** (with an appropriately sized power cable)

Vertical Installation

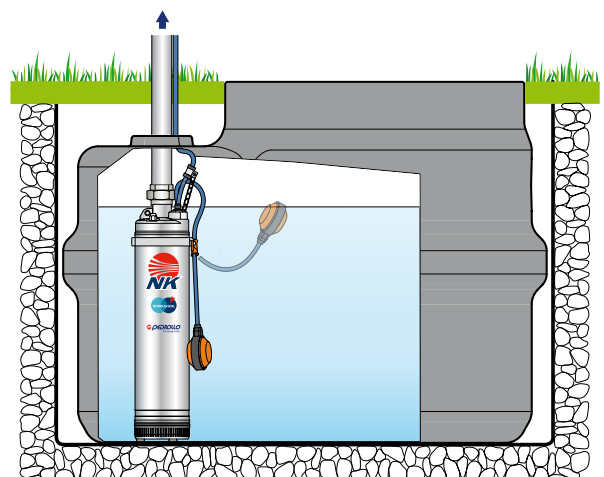

CURVES AND PERFORMANCE DATA

50 Hz

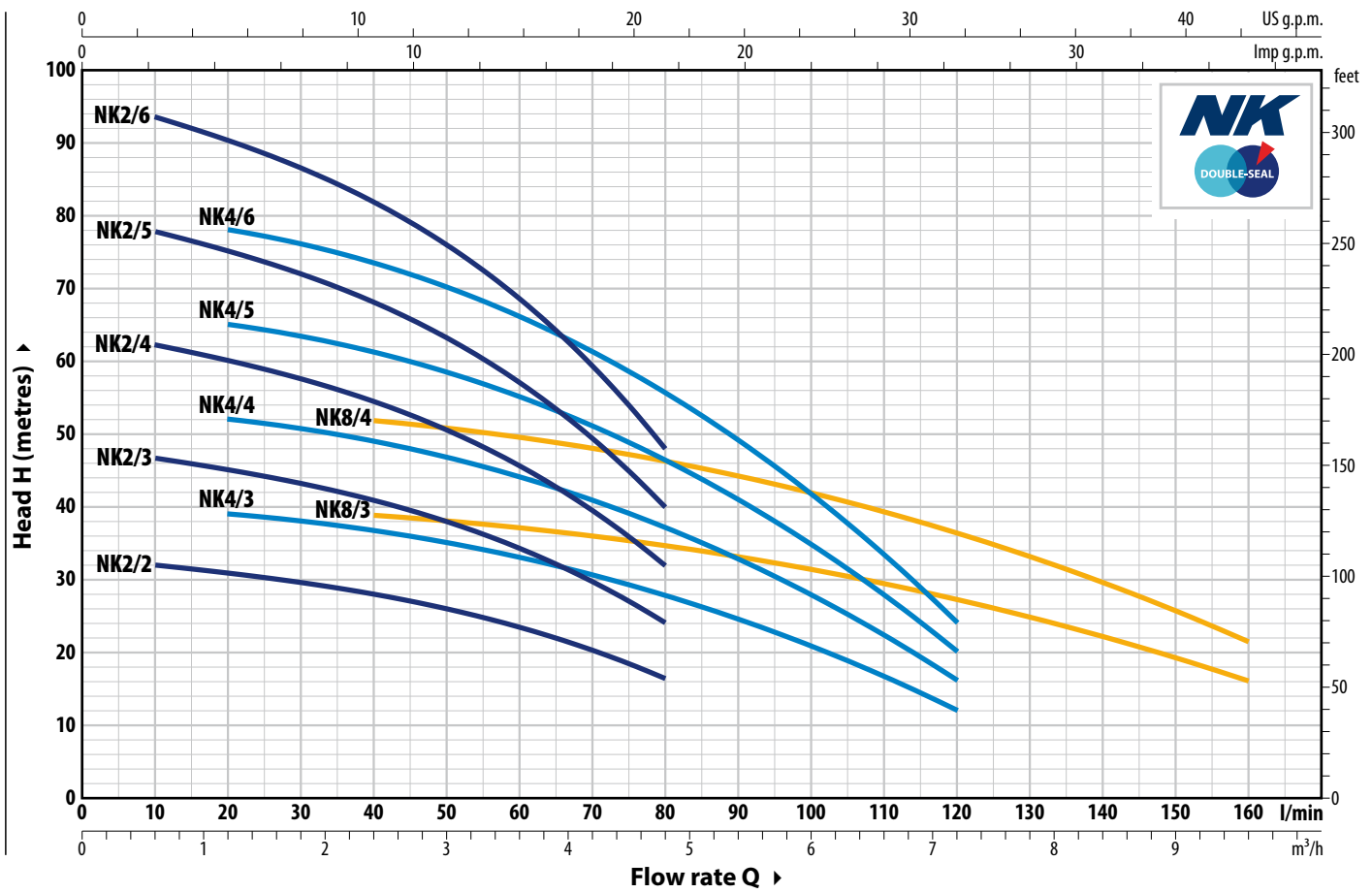

TYPE		POWER (P ₂)		Q	Flow rate															
Single-phase	Three-phase	kW	HP		m ³ /h	0	0.6	1.2	2.4	3.0	3.6	4.2	4.8	6.0	6.6	7.2	8.4	9.6		
				l/min	0	10	20	40	50	60	70	80	100	110	120	140	160			
NKm 2/2 GE	-	0.37	0.5	H metres	33	32	31	28	26	23.5	20.3	16.4								
NKm 2/3 GE	NK 2/3	0.55	0.75		48.5	47	45	41	38	34.5	29.5	24								
NKm 2/4 GE	NK 2/4	0.75	1		64.5	62.5	60.5	54.5	50.5	46	39.5	32								
NKm 2/5 GE	NK 2/5	1.1	1.5		80	78	75	68.5	63.5	57	49.5	40								
NKm 2/6 GE	NK 2/6	1.5	2		97	94	90	82	76	68.5	59.5	48								
NKm 4/3 GE	NK 4/3	0.55	0.75		40	39.5	39	36.5	35	33	30.5	28	20.8	16.6	12					
NKm 4/4 GE	NK 4/4	0.75	1		53	53	52	49	46.5	44	41	37	28	22.2	16					
NKm 4/5 GE	NK 4/5	1.1	1.5		67	66	65	61	58.5	55	51	46.5	34.5	27.5	20					
NKm 4/6 GE	NK 4/6	1.5	2		80	79	78	73	70	66	61	55.5	41.5	33.5	24					
NKm 8/3 GE	NK 8/3	1.1	1.5		40.5	40.5	40	39	38	37.5	36	35	31.5	29.5	27.5	22.3	16.2			
NKm 8/4 GE	NK 8/4	1.5	2	54	54	53.5	52	51	49.5	48	46.5	42	39.5	36.5	29.5	21.6				

Q = Flow rate H = Total manometric head

Performance curves comply with EN ISO 9906 Grade 3B tolerance limits.

⇒ On request single-phase pumps without float switch

ABSORPTION

TYPE	VOLTAGE
Single-phase	230 V
NKm 2/2 GE	4.3 A
NKm 2/3 GE	5.5 A
NKm 2/4 GE	6.2 A
NKm 2/5 GE	7.6 A
NKm2/6 GE	9.2 A
NKm 4/3 GE	5.0 A
NKm 4/4 GE	6.2 A
NKm 4/5 GE	7.5 A
NKm 4/6 GE	8.7 A
NKm 8/3 GE	7.1 A
NKm 8/4 GE	9.2 A

TYPE	VOLTAGE
Three-phase	400 V
NK 2/3	1.9 A
NK 2/4	2.3 A
NK 2/5	3.0 A
NK 2/6	3.4 A
NK 4/3	1.8 A
NK 4/4	2.2 A
NK 4/5	2.8 A
NK 4/6	3.2 A
NK 8/3	2.9 A
NK 8/4	3.4 A

DIMENSIONS AND WEIGHT

TYPE		PORT DN	DIMENSIONS mm		kg	
Single-phase	Three-phase		∅	h	1~	3~
NKm 2/2 GE	–	1 1/4"	135	459	13.1	13.1
NKm 2/3 GE	NK 2/3			486	13.6	13.6
NKm 2/4 GE	NK 2/4			543	15.2	14.4
NKm 2/5 GE	NK 2/5			570	16.6	15.4
NKm 2/6 GE	NK 2/6			617	18.6	17.3
NKm 4/3 GE	NK 4/3			486	13.7	13.5
NKm 4/4 GE	NK 4/4			543	15.2	14.1
NKm 4/5 GE	NK 4/5			570	16.7	15.5
NKm 4/6 GE	NK 4/6			617	18.0	17.8
NKm 8/3 GE	NK 8/3			516	15.5	14.4
NKm 8/4 GE	NK 8/4			563	17.5	16.3

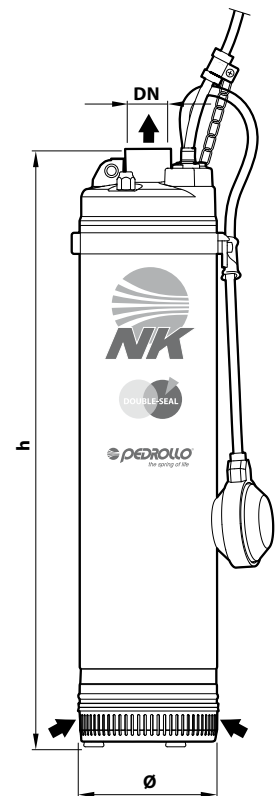

PALLET CAPACITY

TYPE		NO. OF PUMPS
Single-phase	Three-phase	
NKm 2/2 GE	–	30
NKm 2/3 GE	NK 2/3	30
NKm 2/4 GE	NK 2/4	25
NKm 2/5 GE	NK 2/5	25
NKm 2/6 GE	NK 2/6	25
NKm 4/3 GE	NK 4/3	30
NKm 4/4 GE	NK 4/4	25
NKm 4/5 GE	NK 4/5	25
NKm 4/6 GE	NK 4/6	25
NKm 8/3 GE	NK 8/3	30
NKm 8/4 GE	NK 8/4	25

MATERIALS AND COMPONENTS

1 Outer sleeve **AISI 304** stainless steel, fitted with ISO 228/1 threaded delivery port

2 Suction filter **AISI 304** stainless steel, complete with anti-vibration feet

3 Motor sleeve Stainless steel **AISI 304**

4 Impellers and diffusers Noryl™

5 Diaphragms Stainless steel **AISI 304**

6 Motor shaft Stainless steel **AISI 431**

7 Double mechanical seal with interposed oil chamber

Seal	Shaft	Location	Materials
STA-17	Ø 17 mm	Motor side	Ceramic / Graphite / NBR
ST1-16	Ø 16 mm	Pump side	Silicon carbide / Graphite / NBR

8 Capacitor

9 Electric motor

NKm: single-phase 230 V - 50 Hz with winding integrated thermal motor protection

NK: three-phase 400 V - 50 Hz

- Continuous running duty S1
- Insulation: Class F
- Protection rating IP X8

10 Power cord

➔ **DRINCABLE®** type
approved for use in drinking water by **WRAS**
according to BS 6920, approval no. 7513

※ Standard length 10 metres

11 Automatic vent valve

12 Anti-vibration feet

13 Float switch
(exclusive to single-phase models)

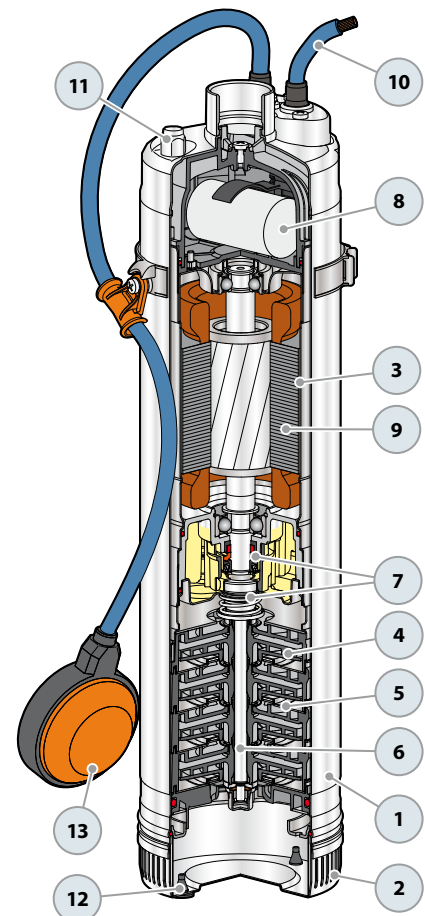

 Clear waters

 Domestic use

※ TOP

**Drainage pumps:
reliable and durable**



PERFORMANCE RANGE

- Flow rate up to **360 l/min** (21.6 m³/h)
- Head up to **15.5 m**

INSTALLATION AND USE

The **TOP** series is excellent for draining **clear water** without abrasive particles. Construction features ensure user-friendly and safe operation, including motor cooling and a double shaft seal. Recommended for emergency drainage of small, flooded areas (rooms, basements, garages), disposing of household water (dishwashers, washing machines), and emptying sumps.

APPLICATION LIMITS

- Liquid temperature up to **+40 °C** and up to **+90 °C** for short bursts (up to 3 minutes max) for intermittent service
- Capable of processing suspended solids up to **Ø 10 mm**
- Draining capability:
 - up to **14 mm** from the bottom for TOP 1-2-3
 - up to **30 mm** from the bottom for TOP 4-5
- Maximum operating depth below water level:
 - up to **3 m** for TOP 1-2-3
 - up to **5 m** for TOP 4-5
 (with an appropriately sized power cable)

PATENTS - TRADE MARKS - MODELS

- Patent No. IT0001428923
- Registered Community Model No. 342159-0011

INCLUDES

- ※ **5 m** power cable
- ※ Float switch

AVAILABLE UPON REQUEST

- ※ Mechanical seal options available
- ※ Different voltage requirements 60 Hz frequency
- ※ Power cable length **10 m**
- ※ **TOP-GM** " pumps with magnetic float operation (suitable for small sumps)
- ※ **TOP-LA** " special pumps with all metal components in contact with the pumped liquid in AISI 316 stainless steel



CURVES AND PERFORMANCE DATA

50 Hz

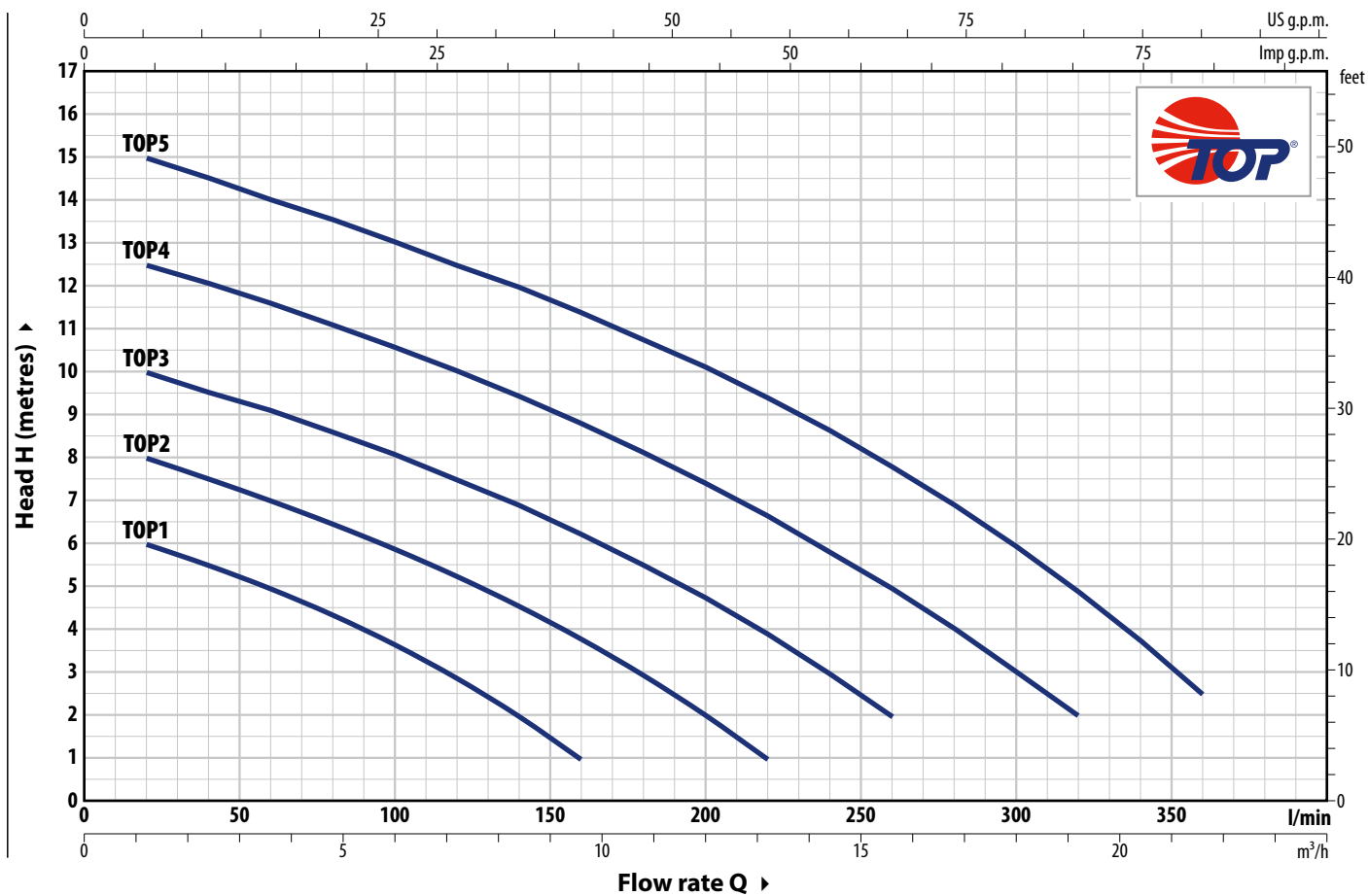

TYPE	POWER (P ₂)		Q	m ³ /h																				
	kW	HP		0	1.2	2.4	3.6	4.8	6.0	7.2	8.4	9.6	10.8	12.0	13.2	14.4	15.6	18.0	19.2	21.6				
Single-phase			l/min	0	20	40	60	80	100	120	140	160	180	200	220	240	260	300	320	360				
TOP 1	0.25	0.33	H metres	6.5	6	5.5	5	4.4	3.7	3	2	1												
TOP 2	0.37	0.50		8.5	8	7.5	7	6.5	6	5.3	4.6	3.8	3	2	1									
TOP 3	0.55	0.75		10.4	10	9.6	9	8.6	8	7.5	7	6.3	5.5	4.8	4	3	2							
TOP 4	0.75	1		13	12.5	12	11.6	11	10.6	10	9.5	8.8	8.2	7.4	6.7	6	5	3	2					
TOP 5	0.92	1.25		15.5	15	14.5	14	13.6	13	12.6	12	11.4	10.8	10	9.4	8.7	7.8	6	5	2.5				

Q = Flow rate H = Total manometric head

Performance curves comply with EN ISO 9906 Grade 3B tolerance limits.

ABSORPTION

TYPE	VOLTAGE
Single-phase	230 V
TOP 1	1.5 A
TOP 2	2.0 A
TOP 3	3.2 A
TOP 4	4.5 A
TOP 5	5.5 A

✘ TOP-LA and TOP-GM pumps have the same performance

DIMENSIONS AND WEIGHT

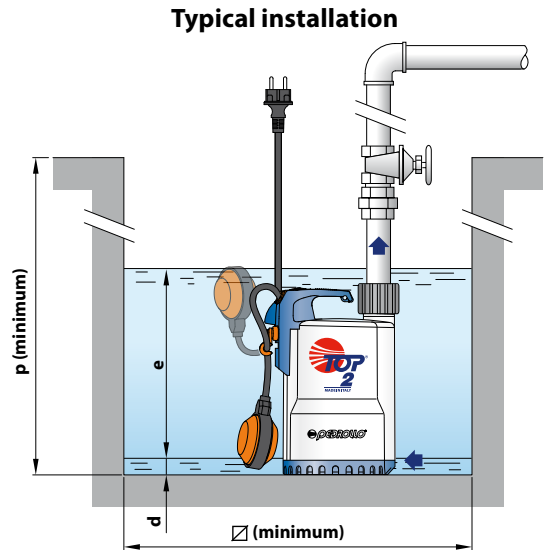
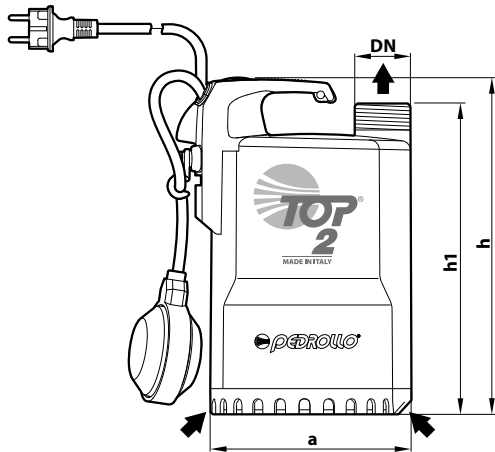

TYPE	PORT DN	DIMENSIONS mm							kg
		a	h	h1	d	e	p	Ø	
Single-phase									
TOP 1	1 1/4"	152	260	240	14	adjustable	350	350	5.4
TOP 2			290	270					5.4
TOP 3									6.7
TOP 4	1 1/2"	204	337	313	30		450	450	10.3
TOP 5									11.3

※ TOP-LA pumps have the same dimensions

※ Version with 'GM' magnetic float switch

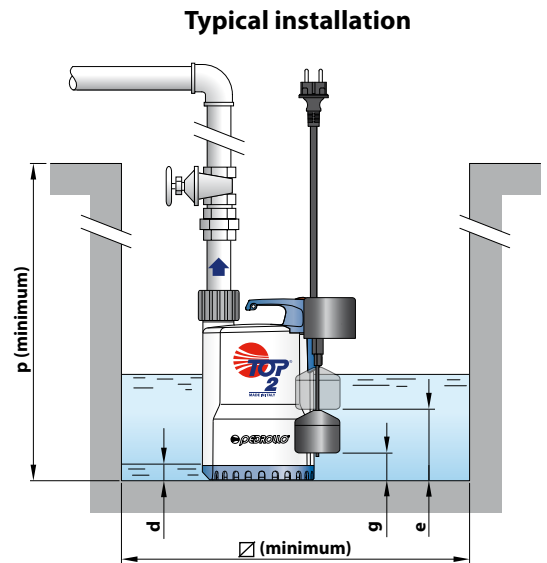
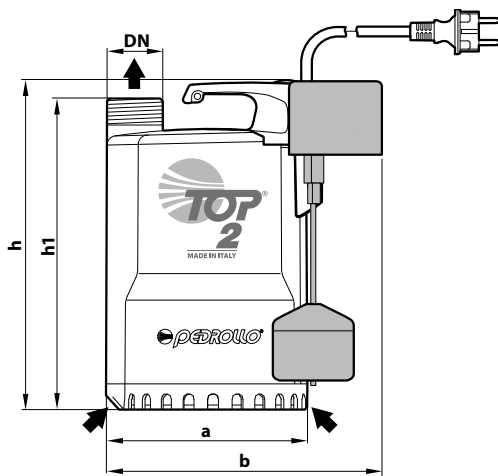

TYPE	PORT DN	DIMENSIONS mm									kg
		a	b	h	h1	d	e	g (adjustable)	p	Ø	
Single-phase											
TOP 1 - GM	1 1/4"	152	200	260	240	14	140	35	350	220	5.4
TOP 2 - GM				290	270		170	40			5.4
TOP 3 - GM											6.9
TOP 4 - GM	1 1/2"	204	-	337	313	30	220	65	450	300	10.5
TOP 5 - GM											11.4

PALLET CAPACITY

TYPE	NO. OF PUMPS
Single-phase	
TOP 1	80
TOP 2	80
TOP 3	80
TOP 4	45
TOP 5	45

TYPE	NO. OF PUMPS
Single-phase	
TOP 1 - GM	80
TOP 2 - GM	80
TOP 3 - GM	80
TOP 4 - GM	45
TOP 5 - GM	45

TOP 1-2-3

MATERIALS AND COMPONENTS

1 Pump body	Technopolymer		
2 Suction filter	Technopolymer		
3 Suction cover	Stainless steel AISI 304 (for TOP-LA versions AISI 316L)		
4 Diffuser	Technopolymer		
5 Impeller	Noryl™		
6 Motor sleeve	Stainless steel AISI 304 (for TOP-LA versions AISI 316L)		
7 Motor cover	AISI 304 stainless steel		
8 Motor shaft	Stainless steel AISI 431 (for TOP-LA versions AISI 316L)		
9 Mechanical seal			
Water pump	Seal	Shaft	Materials
TOP 1-2-3	STA-12R	Ø 12 mm	Ceramic / Graphite / NBR
TOP 2-3 LA	AR-12R LA	Ø 12 mm	Ceramic / Graphite / NBR
10 Sealing ring	Ø 12 x Ø 19 x H 5 mm		
11 Capacitor			
12 Electric motor	TOP: single-phase 230 V - 50 Hz with winding integrated thermal motor protection - Continuous duty S1 - Insulation: class F - Protection rating IP X8		
13 Handle group	Complete with - 5 m power cable type 'H07 RN-F' with Schuko plug - Float switch (vertical operation in GM versions)		
14 Ferrule and hose nozzle	Hose connector Ø 25 mm for TOP 1 Ø 35 mm for TOP 2-3		

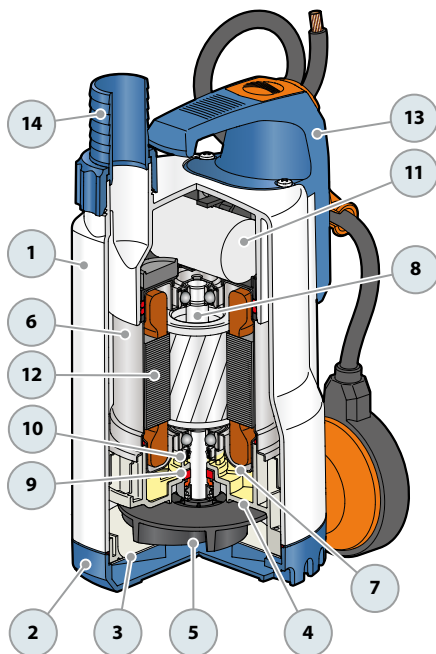

TOP 4-5

MATERIALS AND COMPONENTS

1 Pump body	Technopolymer		
2 Suction filter	Technopolymer		
3 Suction cover	Stainless steel AISI 304		
4 Diffuser	Technopolymer		
5 Impeller	Noryl™		
6 Motor sleeve	Stainless steel AISI 304		
7 Motor cover	Stainless steel AISI 304		
8 Motor shaft	Stainless steel AISI 431		
9 Double mechanical seal with interposed oil chamber			
Seal	Shaft	Location	Materials
MG1-14D SIC	Ø 14 mm	Motor side Pump side	Sic / Graphite / NBR Sic / Sic / NBR
10 Capacitor			
11 Electric motor	TOP: single-phase 230 V - 50 Hz with winding integrated thermal motor protection - Continuous duty S1 - Insulation: class F - Protection rating IP X8		
12 Handle group	Including: - 5 m power cable type 'H07 RN-F' with Schuko plug - Float switch (vertical operation in GM versions)		
13 Sleeve	Threaded technopolymer 1½" with clapet valve		
14 Ferrule and hose nozzle	Hose connector Ø 41 mm		

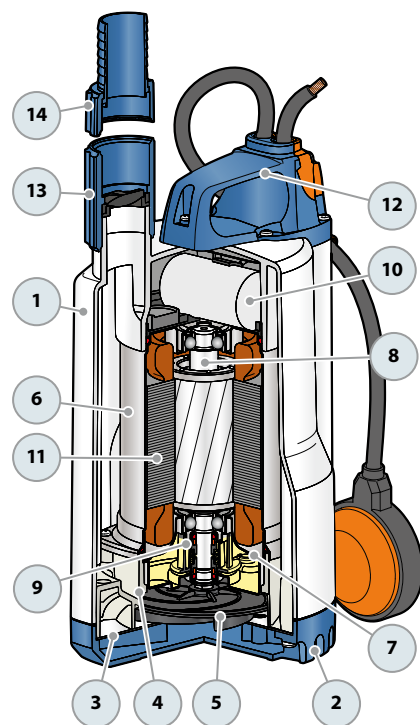

 Clear waters

 Domestic use

※ TOP-FLOOR

Designed to remove water from flooded rooms up to 2 mm from the floor



PERFORMANCE RANGE

- Flow rate up to **170 l/min** (10.2 m³/h)
- Head up to **10.4 m**

INSTALLATION AND USE

Clear water TOP-FLOOR series drainage pumps are capable of removing water up to **2 millimeters** from the floor, these pumps are ideal for emergency household use in small, flooded areas and any situation where maximum drainage is needed.

APPLICATION LIMITS

- Maximum operating depth below water level up to **3 m** (with an appropriately sized power cable)
- Liquid temperature up to **+40 °C** and up to **+90 °C** for short bursts (up to 3 minutes max) for intermittent service
- Capable of processing suspended solids up to **Ø 2 mm**
- Draining capability up to **2 mm** from the bottom

INCLUDES

- ※ **5 m** long power cable

AVAILABLE UPON REQUEST

- ※ Pumps with float switch
- ※ Mechanical seal options available
- ※ Pumps with **10 m** power cable.
- ※ Different voltage requirements 60 Hz frequency

PATENTS - TRADE MARKS - MODELS

- Registered Community Model No. 342159-0011

CURVES AND PERFORMANCE DATA

50 Hz

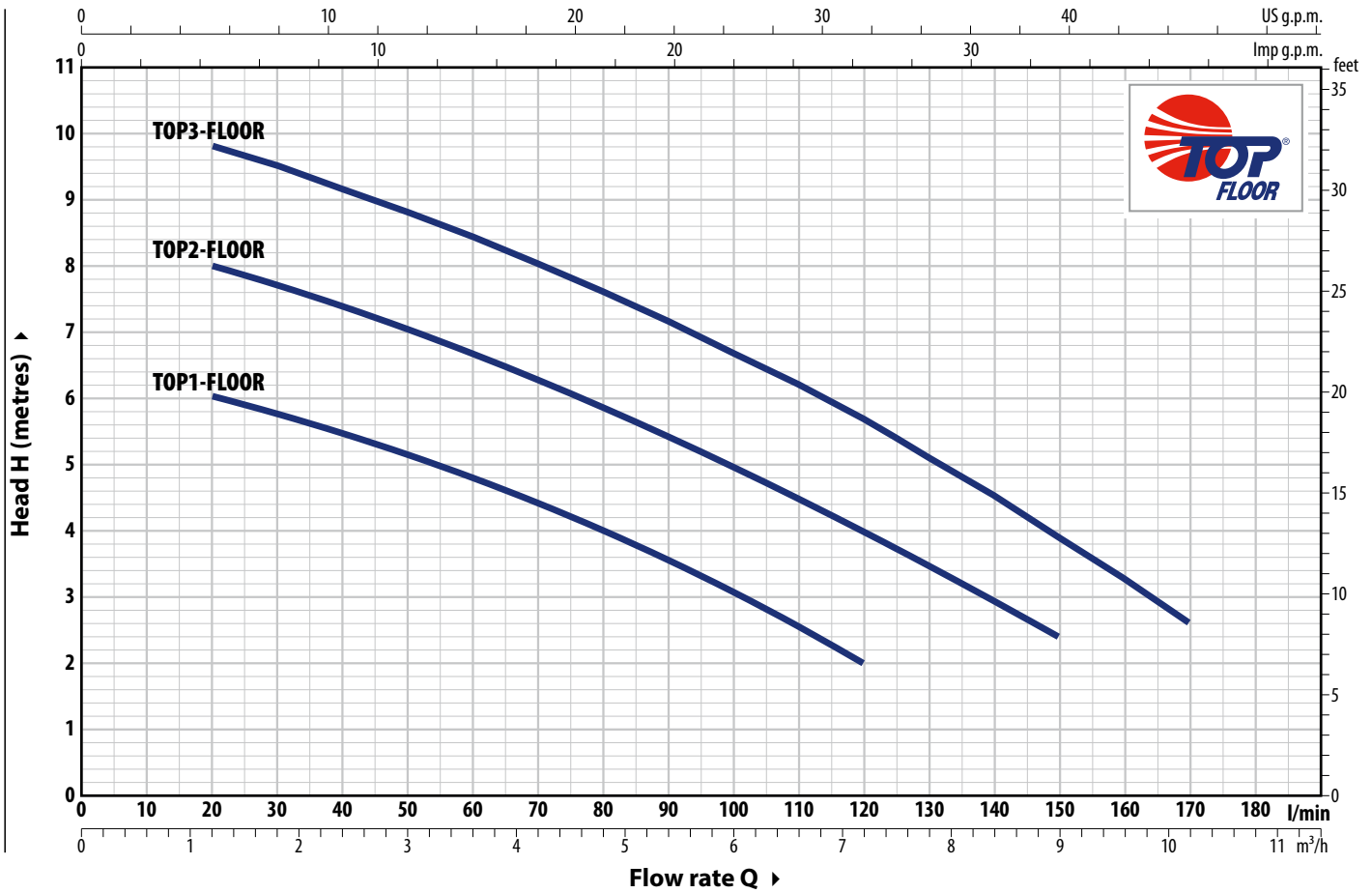

TYPE	POWER (P ₂)		Q	Flow rate												
	kW	HP		0	1.2	2.4	3.6	4.8	6.0	7.2	7.8	9.0	10.2			
Single-phase				0	20	40	60	80	100	120	130	150	170			
TOP 1-FLOOR	0.25	0.33	H metres	6.5	6	5.5	4.8	4	3	2						
TOP 2-FLOOR	0.37	0.50		8.5	8	7.4	6.7	6	5	4	3.5	2.4				
TOP 3-FLOOR	0.55	0.75		10.4	9.8	9.2	8.4	7.6	6.7	5.7	5	4	2.6			

Q = Flow rate H = Total manometric head

Performance curves comply with EN ISO 9906 Grade 3B tolerance limits.

ABSORPTION

TYPE	VOLTAGE
Single-phase	230 V
TOP 1-FLOOR	1.5 A
TOP 2-FLOOR	2.0 A
TOP 3-FLOOR	3.1 A

DIMENSIONS AND WEIGHT

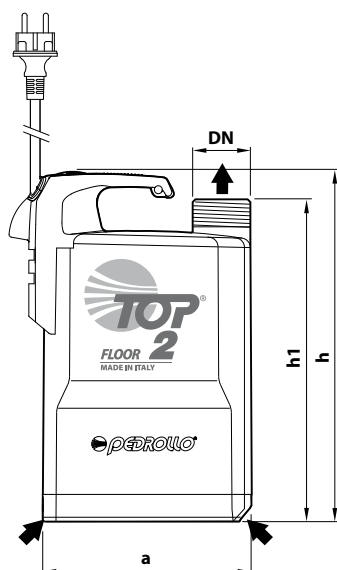

Typical installation



TYPE	PORT DN	DIMENSIONS mm			Minimum drainage level	kg
		a	h	h1		
Single-phase						
TOP 1-FLOOR	1¼"	152	257	237	2 mm	5.2
TOP 2-FLOOR						5.2
TOP 3-FLOOR			287	268		6.6

PALLET CAPACITY

TYPE	NO. OF PUMPS
Single-phase	
TOP 1-FLOOR	96
TOP 2-FLOOR	96
TOP 3-FLOOR	96

MATERIALS AND COMPONENTS

1 Pump body	Technopolymer	
2 Suction filter	Technopolymer	
3 Suction cover	Stainless steel AISI 304	
4 Diffuser	Technopolymer	
5 Impeller	Noryl™	
6 Motor sleeve	Stainless steel AISI 304	
7 Motor cover	Stainless steel AISI 304	
8 Motor shaft	Stainless steel AISI 431	
9 Double shaft seal with interposed oil chamber		
Seal	Shaft	Materials
STA-12R	Ø 12 mm	Ceramic / Graphite / NBR
Sealing ring	Ø 12 x Ø 19 x H 5 mm	

10 Capacitor
11 Electric motor
TOP-FLOOR: single-phase 230 V - 50 Hz with winding integrated thermal motor protection
- Continuous running duty S1
- Insulation: Class F
- Protection rating IP X8

12 Handle group
※ Complete with 5 metres long power cable type 'H07 RN-F' with Schuko plug

13 Ferrule and hose nozzle
Hose connector Ø 25 mm for TOP1-FLOOR
Ø 35 mm for TOP2-FLOOR, TOP3-FLOOR

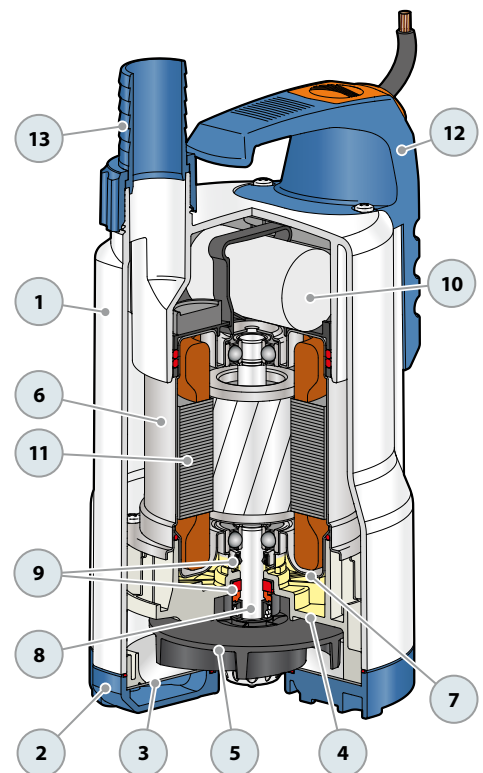

 Dirty water

 Domestic use

※ TOP-VORTEX

**Drainage pumps:
reliable and durable**



PERFORMANCE RANGE

- Flow rate up to **170 l/min** (10.2 m³/h)
- Head up to **8.7 m**

INSTALLATION AND USE

TOP-VORTEX pumps are suitable for draining clear water without abrasive particles that will not damage the pump's components. Construction features ensure user-friendly and safe operation, including motor cooling and a double shaft seal.

These pumps are particularly well-suited for domestic applications, including draining dirty water, emptying tanks, managing domestic drains, and clearing sumps, even in the presence of suspended solids of up to 25 mm in diameter.

APPLICATION LIMITS

- Maximum operating depth below water level up to **3 m** (with an appropriately sized power cable)
- Liquid temperature up to **+40 °C** and up to **+90 °C** for short bursts (up to 3 minutes max) for intermittent service
- Capable of processing suspended solids up to **Ø 25 mm**
- Draining capability up to **25 mm** from the bottom

INCLUDES

- ※ **5 m** power cable
- ※ Float switch

PATENTS - TRADE MARKS - MODELS

- Patent No. IT0001428923
- Registered Community Model No. 342159-0011

AVAILABLE UPON REQUEST

- ※ Mechanical seal options available
- ※ Pumps with **10 m** power cable
- ※ Different voltage requirements 60 Hz frequency
- ※ **TOP-VORTEX/GM** " pumps with magnetic float operation (suitable for small sumps)



※ **TOP-VORTEX/GM**

CURVES AND PERFORMANCE DATA

50 Hz

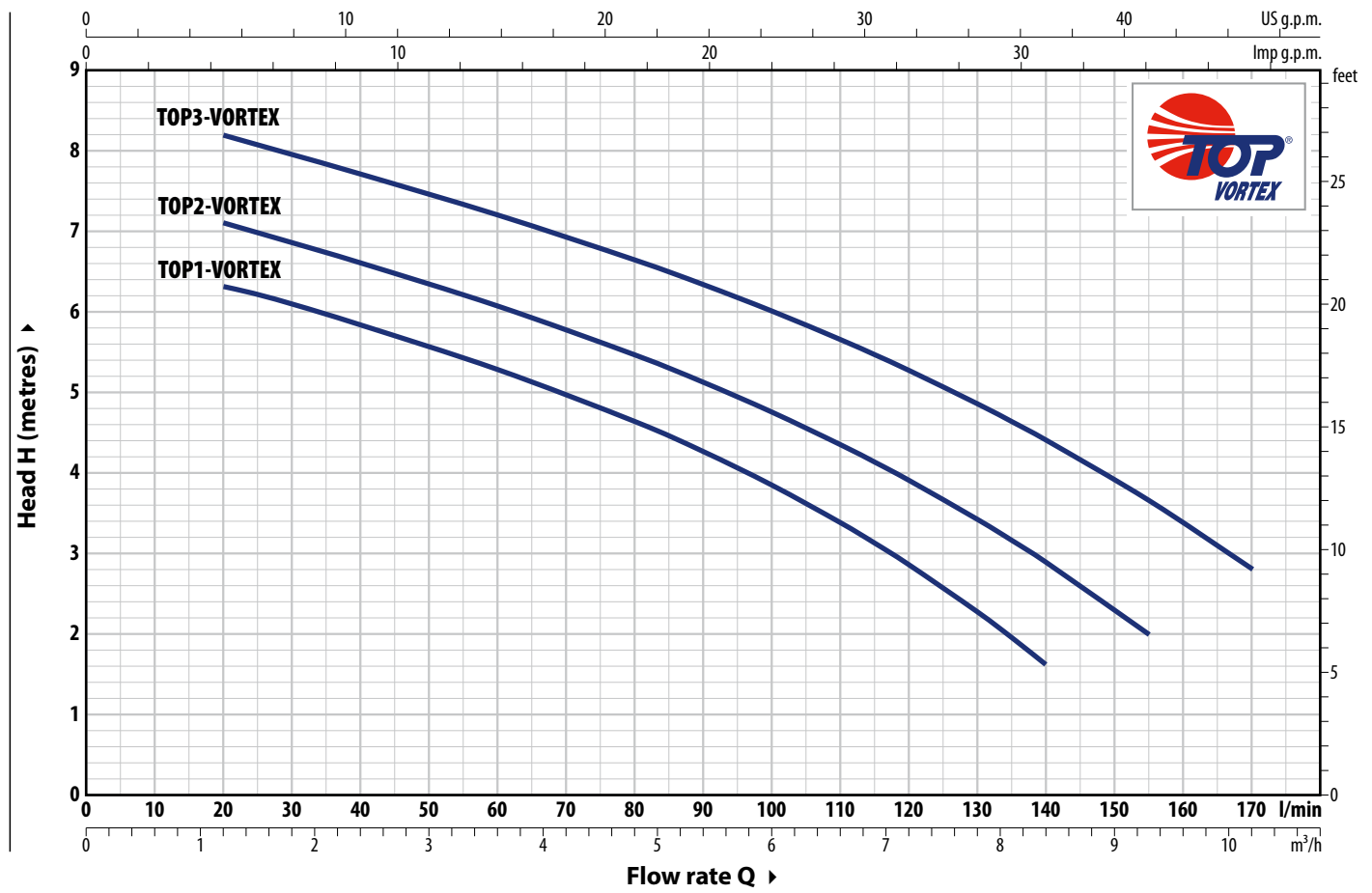

TYPE	POWER (P ₂)		Q	0	1.2	2.4	3.6	4.8	6.0	7.2	8.4	9.3	10.2
	kW	HP		0	20	40	60	80	100	120	140	155	170
Single-phase													
TOP 1 - VORTEX	0.25	0.33	H metres	7	6.3	5.8	5.3	4.6	3.8	2.8	1.6		
TOP 2 - VORTEX	0.37	0.50		7.6	7	6.6	6	5.5	4.8	4	3	2	
TOP 3 - VORTEX	0.55	0.75		8.7	8.2	7.7	7.2	6.7	6	5.3	4.4	3.7	2.8

Q = Flow rate H = Total manometric head

Performance curves comply with EN ISO 9906 Grade 3B tolerance limits.

ABSORPTION

TYPE	VOLTAGE
Single-phase	230 V
TOP 1 - VORTEX	1.5 A
TOP 2 - VORTEX	2.0 A
TOP 3 - VORTEX	2.9 A

DIMENSIONS AND WEIGHT

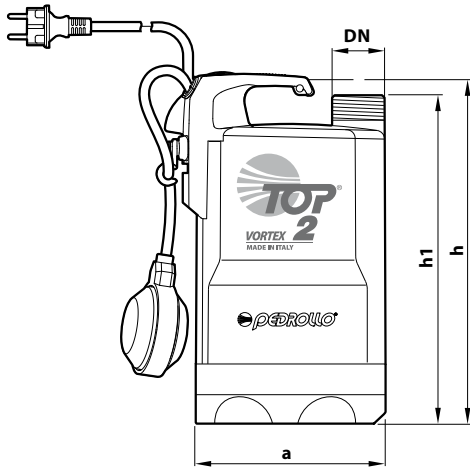

Typical installation

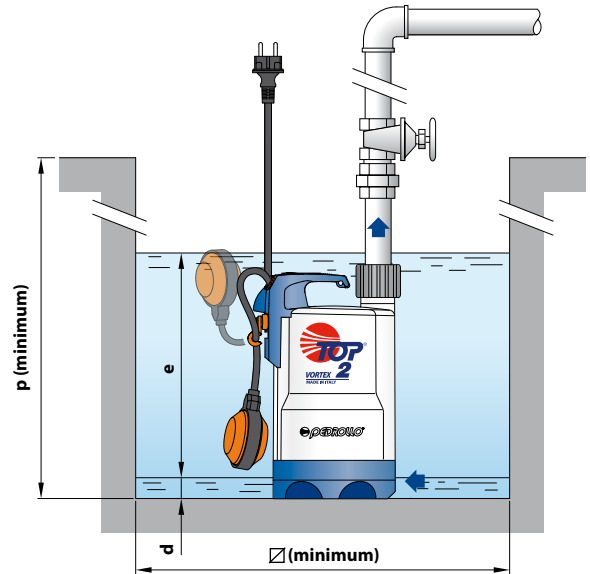

TYPE	PORT DN	DIMENSIONS mm							kg
		a	h	h1	d	e	p	Ø	
Single-phase									
TOP 1 - VORTEX	1 1/4"	152	288	268	25	adjustable	350	350	5.4
TOP 2 - VORTEX			318	298					5.4
TOP 3 - VORTEX									6.8

※ Version with 'GM' magnetic float switch

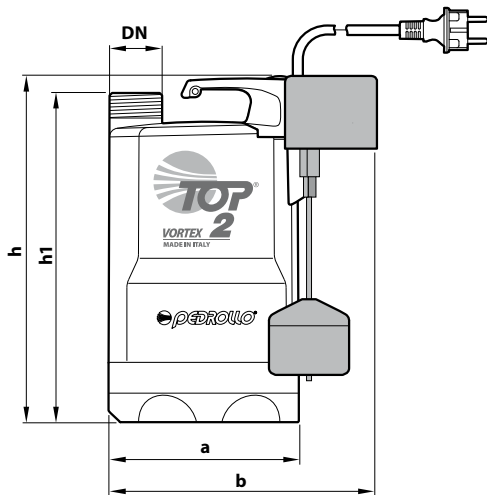

Typical installation

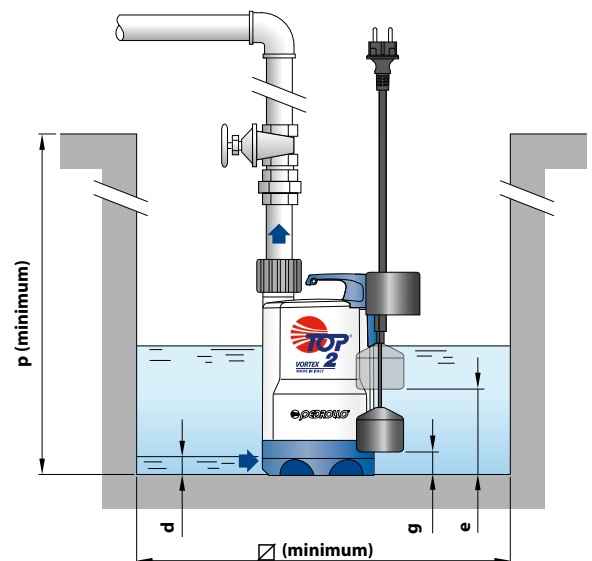

TYPE	PORT DN	DIMENSIONS mm									kg
		a	b	h	h1	d	e	g (adjustable)	p	Ø	
Single-phase											
TOP 1 - VORTEX/GM	1 1/4"	152	200	288	268	25	170	40	350	220	5.5
TOP 2 - VORTEX/GM				318	298						5.5
TOP 3 - VORTEX/GM											6.9

PALLET CAPACITY

TYPE	NO. OF PUMPS
Single-phase	
TOP 1 - VORTEX	96
TOP 2 - VORTEX	96
TOP 3 - VORTEX	96

MATERIALS AND COMPONENTS

1 Pump body	Technopolymer	
2 Suction filter	Technopolymer	
3 Suction cover	Technopolymer	
4 Diffuser	Technopolymer	
5 Impeller	VORTEX technopolymer type	
6 Motor sleeve	Stainless steel AISI 304	
7 Motor cover	Stainless steel AISI 304	
8 Motor shaft	Stainless steel AISI 431	
9 Double shaft seal with interposed oil chamber		
Seal	Shaft	Materials
STA-12R	Ø 12 mm	Ceramic / Graphite / NBR
Shaft seal	Ø 12 x Ø 19 x H 5 mm	

10 Capacitor

11 Electric motor

TOP-VORTEX: single-phase 230 V - 50 Hz with winding integrated thermal motor protection

- Continuous running duty S1
- Insulation: Class F
- Protection rating IP X8

12 Handle group

Including:

- Float switch (vertically operating float switch in GM versions)
- 5 metres power cable type 'H07 RN-F' with Schuko plug

13 Ferrule and hose nozzle

Hose connector Ø 35 mm

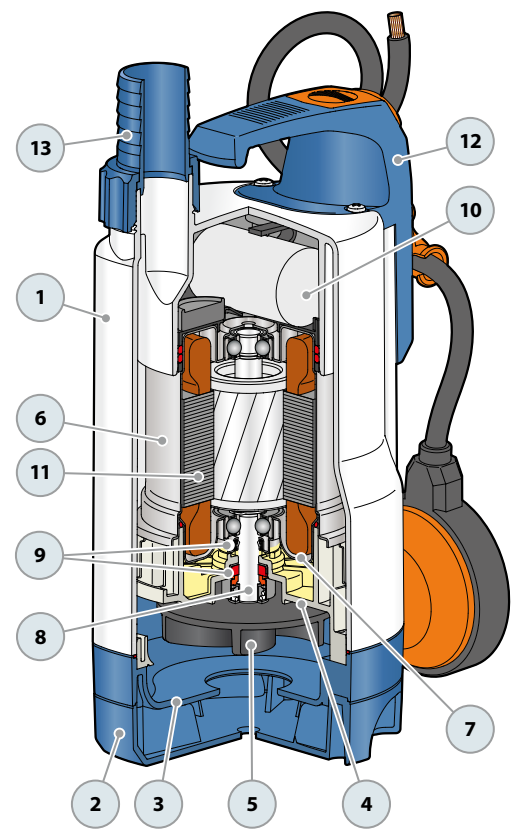

Dirty water



Domestic use

※ **TEX: reliable water elimination with magnetic level switch**



- ※ **Innovative, patented design**
- ※ **Premium quality**
- ※ **Ideal for sumps with limited space**

- ※ **Robust and compact**
- ※ **Equipped with retractable handle**
- ※ **Exceptional performance**

PERFORMANCE RANGE

- Flow rate up to **240 l/min** (14.4 m³/h)
- Head up to **10 m**

INSTALLATION AND USE

TEX electric sewage pumps offer a dependable solution for wastewater management. Primarily utilized in stationary setups to remove water from sumps, they are also suitable for portable applications, such as tanks, reservoirs, ditches, or during floods.

TEX pumps offer increased power and a larger clearance area, while the oversized motor prevents overheating even when operating without cover.

※ Key features include a spacious side drain for rapid water evacuation with minimal energy consumption.

※ Additionally, **TEX** pumps come equipped with a compact, integrated magnetic float switch that ensures complete electrical safety and enables usage in confined spaces, including sumps as small as **220 mm** on each side.

APPLICATION LIMITS

- Maximum operating depth below water level up to **5 m** (with an appropriately sized power cable)
- Liquid temperature up to **+40 °C** and up to **+90 °C** for short bursts (up to 3 minutes max) for intermittent service
- Capable of processing suspended solids up to **Ø 30 mm**
- Draining capability up to **35 mm** from the bottom

INCLUDES

- ※ **5 m** power cable
- ※ An adjustable vertical magnetic float level switch
- ※ Hose connector **Ø 40 mm**

AVAILABLE UPON REQUEST

- ※ Mechanical seal options available
- ※ Pumps with **10 m** power cable.
- ※ Different voltage requirements 60 Hz frequency

PATENTS - TRADE MARKS - MODELS

- Registered Community Model No. 005205556
- **TEX[®]** European registered trademark No. 017884160

CURVES AND PERFORMANCE DATA

50 Hz

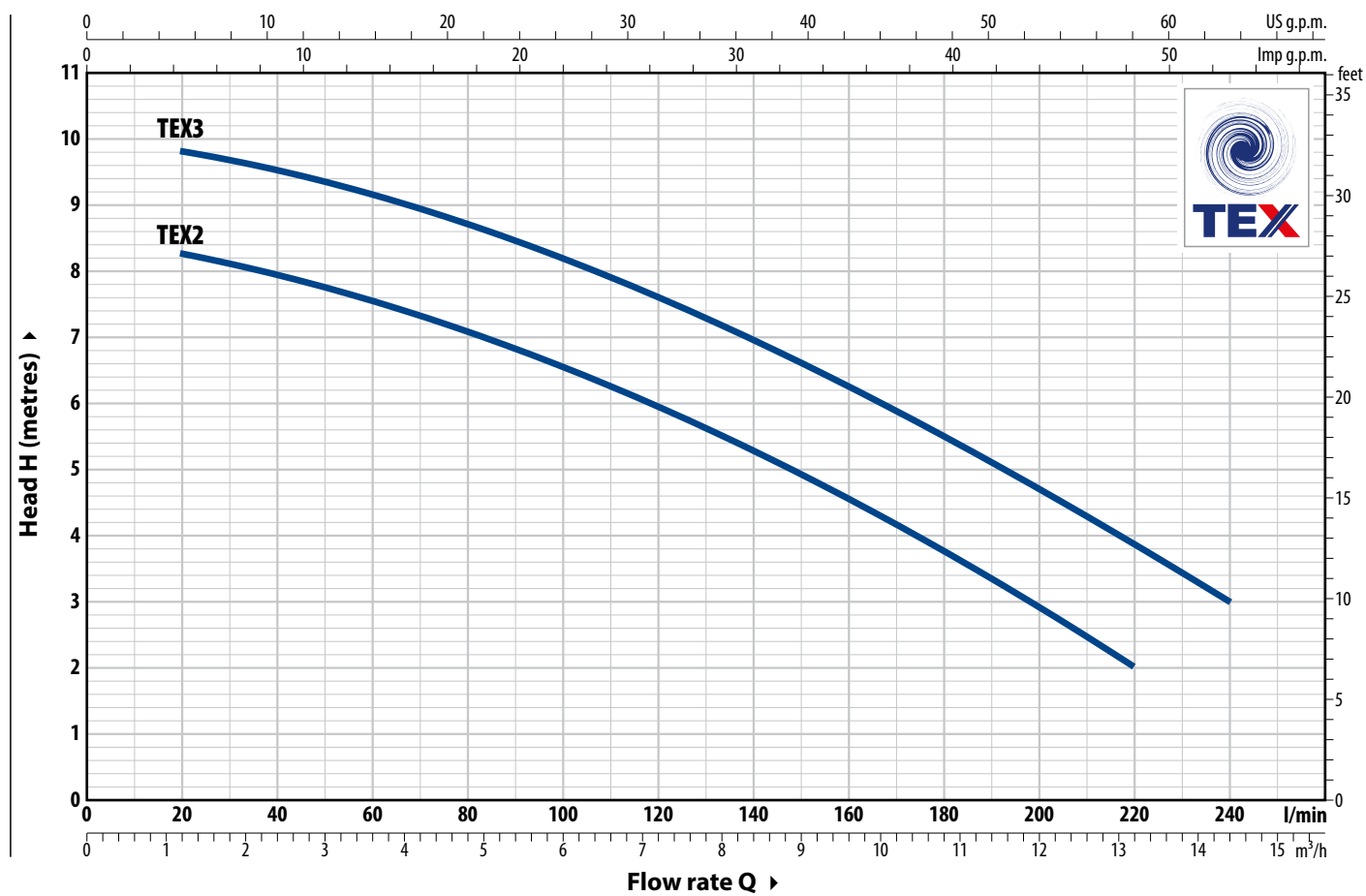

TYPE Single-phase	POWER (P ₂)		Q	0	1.2	2.4	3.6	4.8	6	7.2	8.4	9.6	10.8	12	13.2	14.4
	kW	HP		0	20	40	60	80	100	120	140	160	180	200	220	240
TEX 2	0.37	0.50	H metres	8.5	8.3	8	7.6	7	6.6	6	5.3	4.6	3.8	3	2	
TEX 3	0.55	0.75		10	9.8	9.5	9.2	8.7	8.2	7.6	7	6.3	5.5	4.7	4	3

Q = Flow rate H = Total manometric head

Performance curves comply with EN ISO 9906 Grade 3B tolerance limits.

RETRACTABLE HANDLE



ABSORPTION

TYPE	VOLTAGE
Single-ph.	230 V
TEX 2	2.3 A
TEX 3	3.3 A

SWITCH FOR AUTOMATIC MODE



SWITCH FOR MANUAL MODE



DIMENSIONS AND WEIGHT

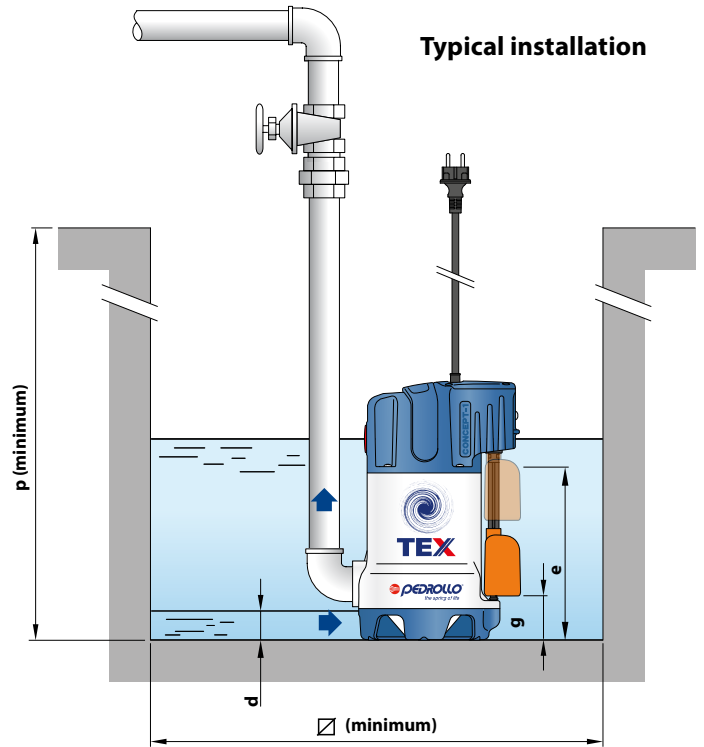
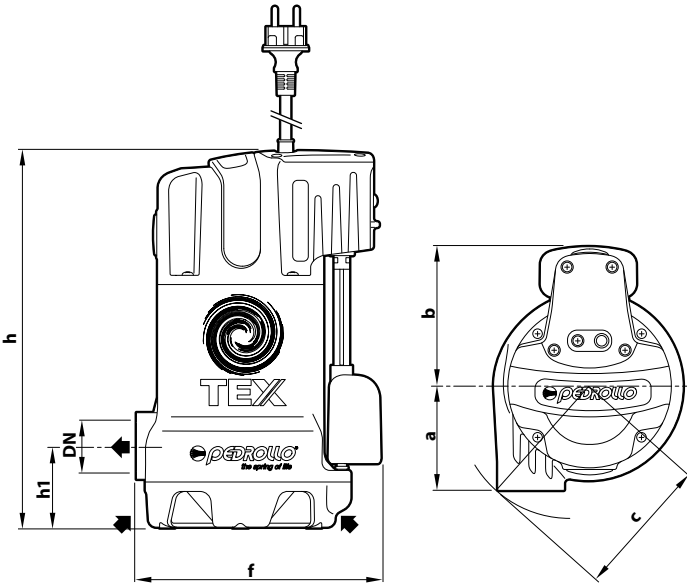

Rubber holder fitting

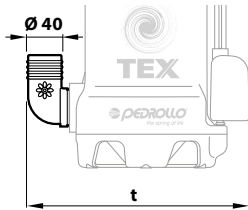

TYPE Single-phase	PORT DN	Passage of solid bodies	DIMENSIONS mm													kg 1~
			a	b	c	f	h1	h	d	e	g (adjustable)	t	p	Ø		
TEX 2	1 1/4"	Ø 30 mm	88	117	118	205	69.5	318	35	100	80 or 100	251	350	220	6.1	
TEX 3															7.0	

PALLET CAPACITY

TYPE Single-phase	NO. OF PUMPS
TEX 2	60
TEX 3	60

MATERIALS AND COMPONENTS

1 Handle	Technopolymer	
2 Pump body	Particularly impact-resistant technopolymer with ISO 228/1 threaded metal insert port	
3 Suction filter	Technopolymer	
4 Suction cover	Technopolymer	
5 Impeller	VORTEX type made of technopolymer	
6 Motor sleeve	Stainless steel AISI 304	
7 Motor cover	Stainless steel AISI 304	
8 Motor shaft	Stainless steel AISI 431	
9 Double shaft seal with interposed oil chamber		
Seal	Shaft	Materials
STA-12R	Ø 12 mm	Ceramic / Graphite / NBR
Shaft seal	Ø 12 x Ø 19 x H 5 mm	
10 Capacitor		
11 Electric motor	<p>TEX: single-phase 230 V - 50 Hz with winding integrated thermal motor protection</p> <ul style="list-style-type: none"> - Continuous running duty S1 - Insulation: Class F - Protection rating IP X8 	
12 Power cord	<p>Type 'H07 RN-F' with Schuko plug ✳ Standard length 5 metres</p>	
13 Float level switch	Float magnetic vertical solid adjustable	
14 Hose connector	Ø 40 mm	

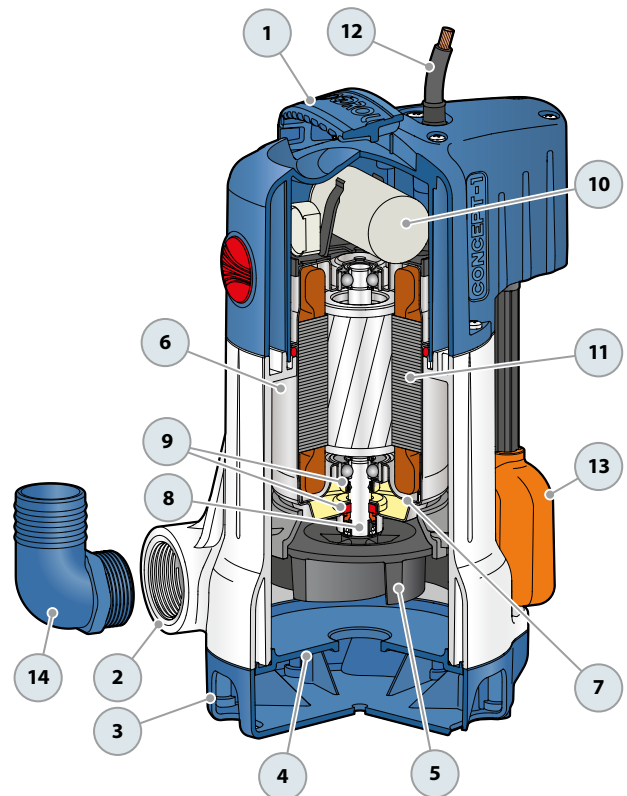



INSTALLATION AND USE

TOP MULTI 1-AD submersible pumps are engineered to handle AUS32 (Aqueous Urea Solution 32.5%), a clean liquid meeting ISO 22241 standards. This solution is also recognized globally under:

- ✳ **AdBlue®** (registered trademark of Verband der Automobilindustrie VDA);
- ✳ **DEF** (Diesel Exhaust Fluid);
- ✳ **Arla 32** (Agente Redutor Liquido de Óxido de Nitrogênio Automotivo).

APPLICATION LIMITS

- Depth of use below liquid level up to **3 m**
- Liquid temperature up to **+40 °C**
- Draining capability up to **25 mm** from the bottom

INCLUDES

- ✳ **5 m** long power cable with H07BN4-F sheathing
- ✳ Complete sleeve with clapet valve

AVAILABLE UPON REQUEST

- ✳ Different voltage requirements 60 Hz frequency
- ✳ 10 metres long power cable

CURVES AND PERFORMANCE DATA

50 Hz

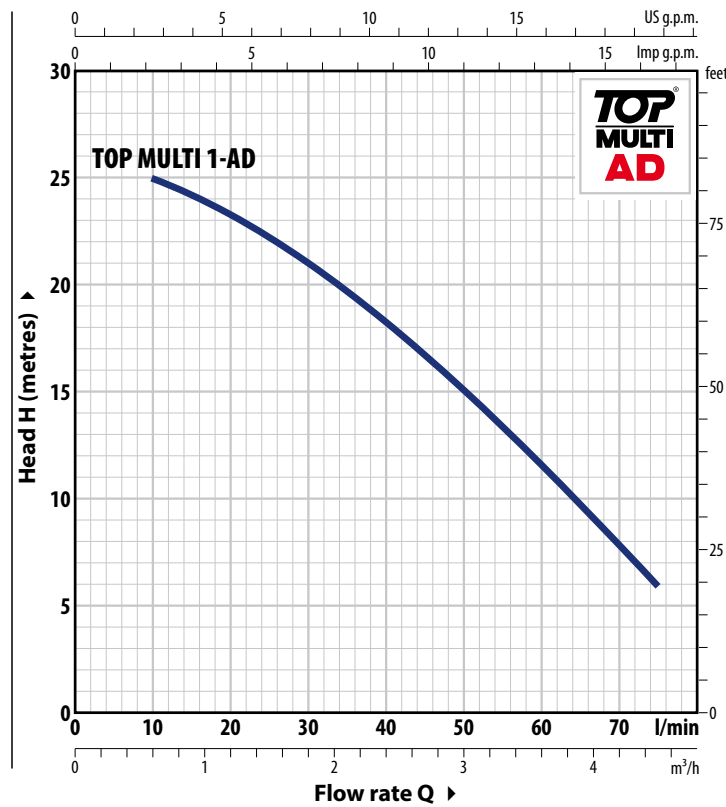

ABSORPTION

TYPE	VOLTAGE
Single-phase	230 V
TOP MULTI 1-AD	2.0 A

TYPE	POWER (P ₂)		Q	Flow rate									
	kW	HP		m³/h	0	0.6	1.2	1.8	2.4	3.0	3.6	4.2	4.5
Single-phase			l/min	0	10	20	30	40	50	60	70	75	
TOP MULTI 1-AD	0.37	0.50	H metres	26	25	23.3	21	18.3	15	11.6	8	6	

MATERIALS AND COMPONENTS

1 Pump body	Technopolymer with ISO 228/1 threaded delivery port										
2 Suction filter	Technopolymer										
3 Containment stages	Technopolymer										
4 Impeller	Noryl™										
5 Diffuser	Noryl™										
6 Diffuser vanes	Technopolymer										
7 Motor sleeve	Stainless steel AISI 304										
8 Motor cover	Stainless steel AISI 304										
9 Motor shaft	Stainless steel AISI 431										
10 Double shaft seal	<table border="1"> <thead> <tr> <th>Seal</th> <th>Shaft</th> <th>Materials</th> </tr> </thead> <tbody> <tr> <td>STA-12R SGE</td> <td>Ø 12 mm</td> <td>Silicon carbide / Graphite / EPDM</td> </tr> <tr> <td>Shaft seal</td> <td colspan="2">Ø 12 x Ø 19 x H 5 mm</td> </tr> </tbody> </table>		Seal	Shaft	Materials	STA-12R SGE	Ø 12 mm	Silicon carbide / Graphite / EPDM	Shaft seal	Ø 12 x Ø 19 x H 5 mm	
Seal	Shaft	Materials									
STA-12R SGE	Ø 12 mm	Silicon carbide / Graphite / EPDM									
Shaft seal	Ø 12 x Ø 19 x H 5 mm										
11 Capacitor											
12 Electric motor	<p>TOP MULTI-AD: Single-phase 230 V - 50 Hz with winding integrated thermal motor protection</p> <ul style="list-style-type: none"> - Continuous running duty S1 - Insulation: Class F - Protection rating IP X8 										
13 Handle group	※ Complete with 5 metres long power cable type 'H07BN4-F'.										
14 Sleeve	Threaded 1¼" ISO 228/1 with built-in clapet valve (Included in delivery) 										

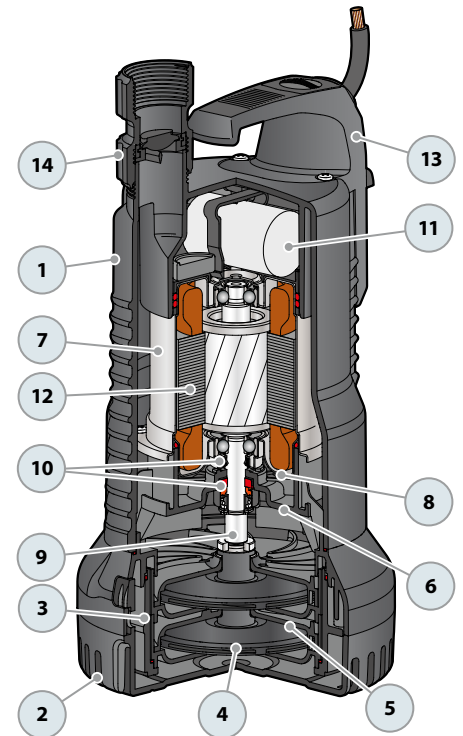

DIMENSIONS AND WEIGHTS (mm)

TYPE	PORT DN	N° STAGES	DIMENSIONS mm							kg
			a	b	h	h1	d	p	∅	
Single-phase										
TOP MULTI 1-AD	1¼"	2	170	180	295	315	25	350	220	5.9

PALLET CAPACITY

TYPE	NO. OF PUMPS
Single-phase	
TOP MULTI 1-AD	60

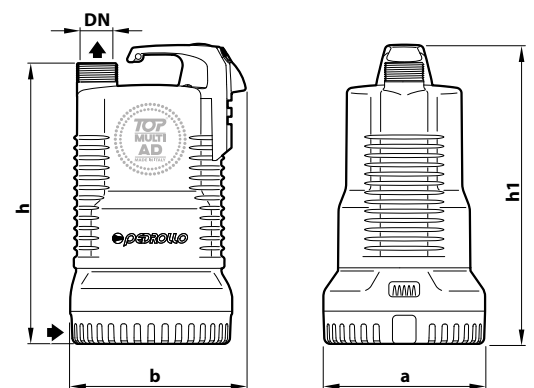

PLUG & DRAIN

Ready-to-use anti-flooding kit



- ※ **PLUG & DRAIN** is the essential emergency kit for fast and effective flood management in garages, basements, and cellars.
- ※ Features a high-performance drainage pump and a 12.5-metre-long PVC hose for quick water evacuation, plus the option to use the storage case as a filter.

- ※ **PLUG & DRAIN** efficiently lowers water to just about 2 mm from the ground, ensuring nearly complete removal.
- ※ Comes in a convenient carrying case that simplifies transport and doubles as a filter while you're draining.

PLUG & DRAIN Code. ASSKPDSTO2FA1

※ STANDARD COMPONENTS

SUBMERSIBLE Pump TOP2-FLOOR

- Single-phase **230 V - 50 Hz**
- Performance:
 - H max= **8.5 m**
 - Q max= **150 l/min**
- **10 metres** long power cable with Schuko plug
- Float switch
- **STORZ'** quick coupling
- Draining capability up to **2 mm** from the bottom



PVC HOSE

- **STORZ'** quick coupling
- Hose length **12.5 m**
- Pipe diameter **1 1/4"**



FILTER-BOX

- Features a secure pump attachment system for stable operation, with a quick-release option to use the pump independently
- Includes a cover for tidy storage, ensuring it's always ready for immediate use



※ PLUG & DRAIN WITH Pumps ON REQUEST

TOP3

- Performance:
- H max= **10.4 m**
 - Q max= **260 l/min**

CODE ASSKPDSTOP3A1



RXm 2

- Performance:
- H max= **10.3 m**
 - Q max= **190 l/min**

CODE ASSKPDSTRX2A1



RXm 3

- Performance:
- H max= **12.3 m**
 - Q max= **220 l/min**

CODE ASSKPDSTRX3A1





TECHNICAL SPECIFICATIONS		※ SERIES MODEL	※ AVAILABLE MODELS		
		TOP 2-FLOOR	TOP 3	RXm 2	RXm 3
SPECIFICATIONS	Pump type	Submersible	Submersible	Submersible	Submersible
	Pump control	Float	Float	Float	Float
MATERIALS	Pump body	Technopolymer	Technopolymer	AISI 304 stainless steel	AISI 304 stainless steel
	Impeller	Noryl™	Noryl™	AISI 304 stainless steel	AISI 304 stainless steel
	Mechanical seal	Ceramic/Graphite/NBR	Ceramic/Graphite/NBR	Ceramic/Graphite/NBR	Ceramic/Graphite/NBR
PERFORMANCE	Draining capability from the bottom	2 mm	14 mm	14 mm	14 mm
	Maximum depth of immersion	3 m	3 m	10 m	10 m
	Maximum size of suspended solids	2 mm	10 mm	10 mm	10 mm
FITTINGS	Pump connections	1 ¼" M	1 ¼" M	1 ¼" F	1 ¼" F
MOTOR ELECTRIC	Outlet port				
	Typology	Asynchronous (with automatic reset thermal protector)	Asynchronous (with automatic reset thermal protector)	Asynchronous (with automatic reset thermal protector)	Asynchronous (with automatic reset thermal protector)
	Electric power supply	~ 230 V / 50 Hz	~ 230 V / 50 Hz	~ 230 V / 50 Hz	~ 230 V / 50 Hz
	Consumption	450 W	700 W	450 W	800 W
	CURRENT AT FULL LOAD	2.0 A	3.2 A	2.0 A	3.6 A
	Power cord (pre-wired)	10 m with Schuko plug	10 m with Schuko plug	10 m with Schuko plug	10 m with Schuko plug
Service index	Continuous running duty (S1)	Continuous running duty (S1)	Continuous running duty (S1)	Continuous running duty (S1)	

DIMENSIONS AND WEIGHT

TYPE	DIMENSIONS mm			kg*
	a	b	h	
PLUG & DRAIN - TOP 2-FLOOR	400	300	320	10.5
PLUG & DRAIN - TOP 3	400	300	362	12.9
PLUG & DRAIN - RXm 2	400	300	362	11.6
PLUG & DRAIN - RXm 3	400	300	362	13.1

(* Total weight: pump, hose, fittings and box)

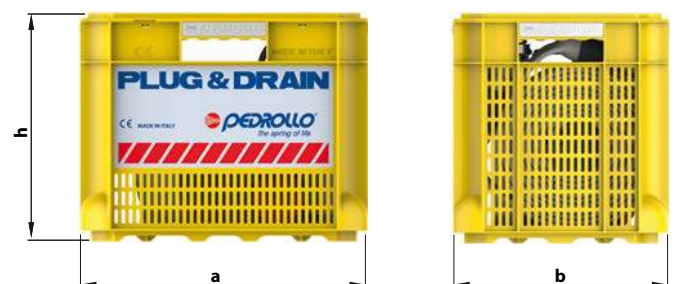

-  Clear waters
-  Domestic use
-  Civil use

※ Pumps entirely made of stainless steel



PERFORMANCE RANGE

- Flow rate up to **320 l/min** (19.2 m³/h)
- Head up to **20.5 m**

INSTALLATION AND USE

RX pumps are designed for efficiently draining **clear water** without abrasive particles. Their design ensures user-friendly operation and safe performance, thanks to complete motor cooling and a double shaft seal. Ideal for home and public applications, these pumps are perfect for permanent setups, quickly handling emergency situations like small floods in rooms, basements, and garages. They're also great for managing household wastewater from dishwashers and washing machines, as well as for sump emptying.

APPLICATION LIMITS

- Maximum operating depth below water level up to **10 m** (with an appropriately sized power cable)
- Liquid temperature up to **+50 °C** and up to **+90 °C** for short bursts (up to 3 minutes max) for intermittent service
- Capable of processing suspended solids up to **Ø 10 mm**
- Draining capability:
 - up to **14 mm** from the bottom for RX 1-2-3
 - up to **25 mm** from the bottom for RX 4-5

PATENTS - TRADE MARKS - MODELS

- Patent No. EP2313658
- Patent No. IT0001428923

INCLUDES

- ※ **5 m** power cable
- ※ Float switch for single-phase versions

AVAILABLE UPON REQUEST

- ※ Mechanical seal options available
- ※ Pumps with **10 m** power cable
- ※ Different voltage requirements 60 Hz frequency
- ※ **RX-GM** pumps with magnetic float switch (suitable for small sumps)



※ **RX-GM**

CURVES AND PERFORMANCE DATA

50 Hz

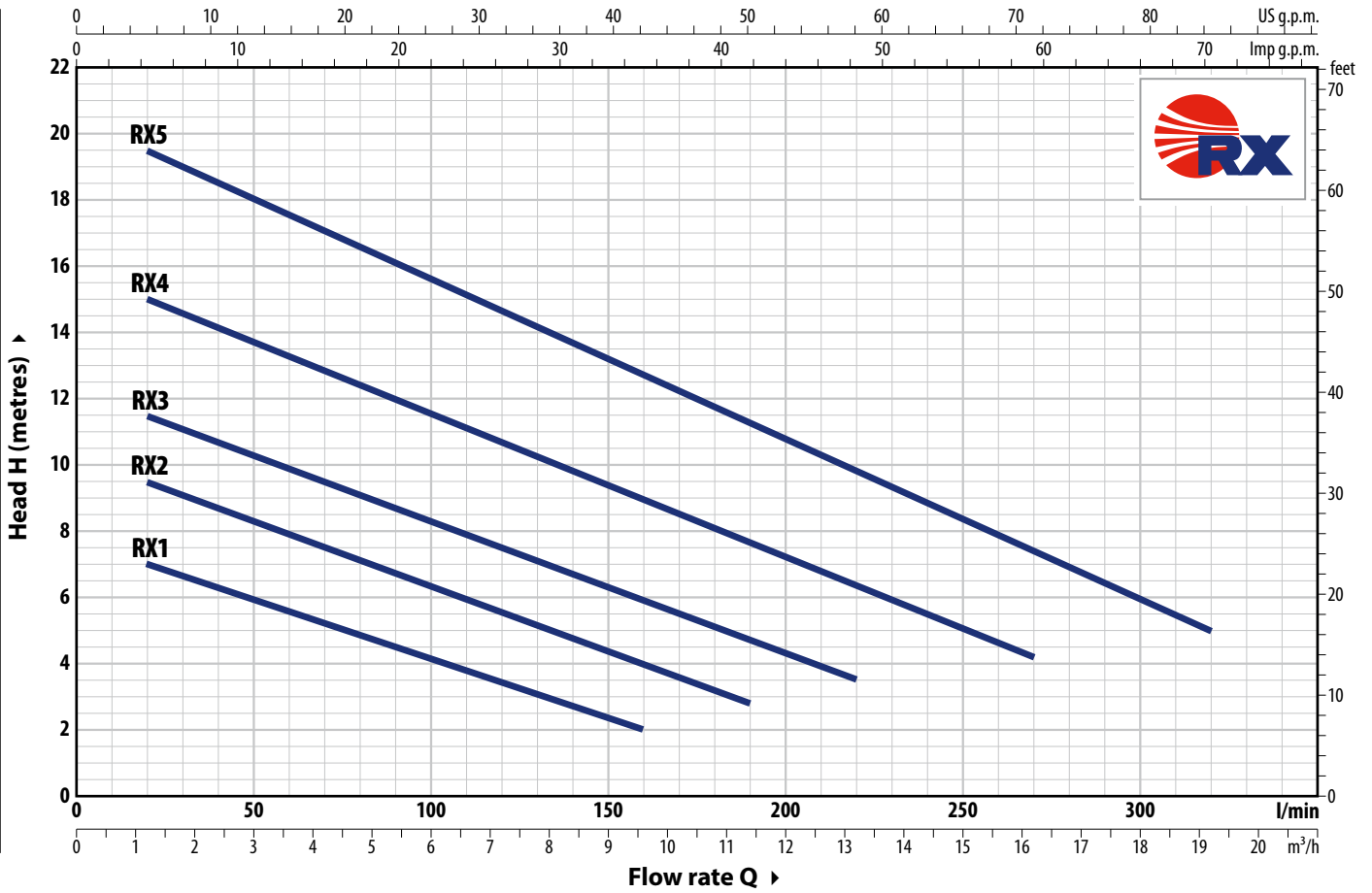

TYPE		POWER (P ₂)		Q	m ³ /h														
Single-ph.	Three-ph.	kW	HP		0	1.2	3.6	6	7.8	9.6	11.4	13.2	14.4	16.2	18	19.2			
				l/min	0	20	60	100	130	160	190	220	240	270	300	320			
RXm 1	RX 1	0.25	0.33	H metres	7.7	7	5.6	4	3	2									
RXm 2	RX 2	0.37	0.50		10.3	9.5	8	6.4	5.2	4	2.8								
RXm 3	RX 3	0.55	0.75		12.3	11.5	10	8.3	7	6	4.7	3.5							
RXm 4	RX 4	0.75	1		16	15	13.3	11.5	10.3	9	7.7	6.4	5.5	4.2					
RXm 5	RX 5	1.1	1.5		20.5	19.5	17.6	15.6	14.2	12.7	11.3	9.8	9	7.4	6	5			

Q = Flow rate H = Total manometric head

Performance curves comply with EN ISO 9906 Grade 3B tolerance limits.

ABSORPTION

TYPE	VOLTAGE
Single-phase	230 V
RXm 1	1.5 A
RXm 2	2.0 A
RXm 3	3.6 A
RXm 4	5.9 A
RXm 5	7.5 A

TYPE	VOLTAGE
Three-phase	400 V
RX 1	0.9 A
RX 2	1.0 A
RX 3	1.6 A
RX 4	2.1 A
RX 5	3.5 A

DIMENSIONS AND WEIGHT

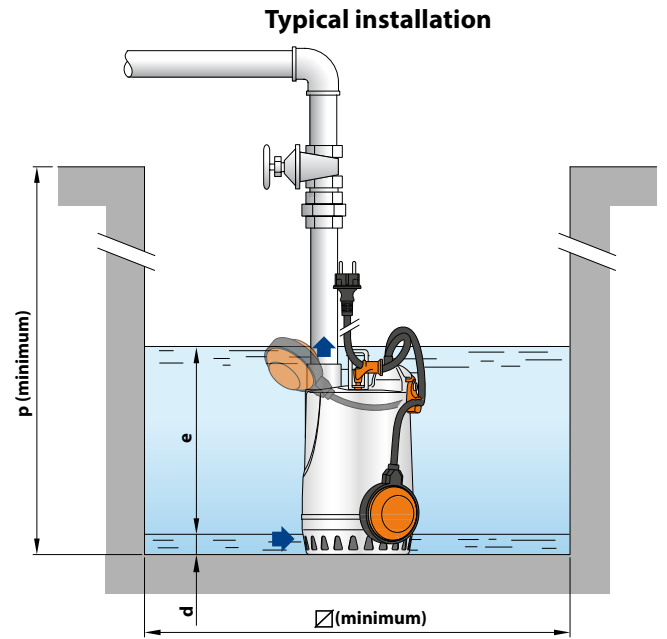
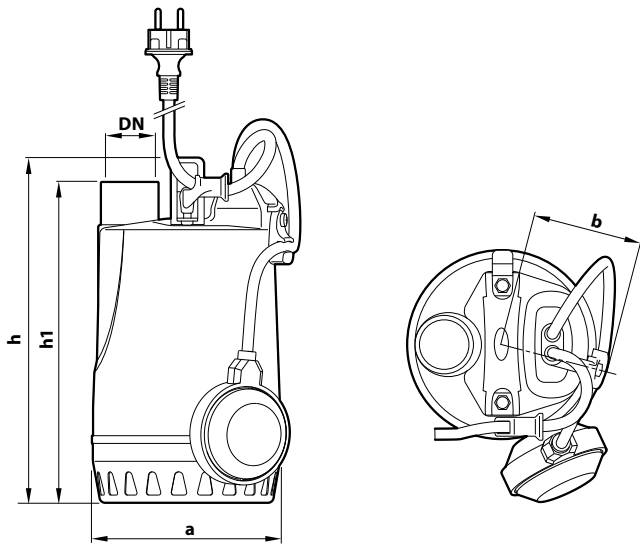

TYPE		PORT	DIMENSIONS mm								kg		PALLET CAPACITY
Single-phase	Three-phase	DN	a	b	h	h1	d	e	p	Ø	1~	3~	
RXm 1	RX 1	1 1/4"	147	84	268	243	14	adjustable	350	350	6.1	5.7	96
RXm 2	RX 2				298	273					6.1	5.7	96
RXm 3	RX 3				298	273					7.6	7.1	96

※ Version with 'GM' magnetic float switch

Typical installation

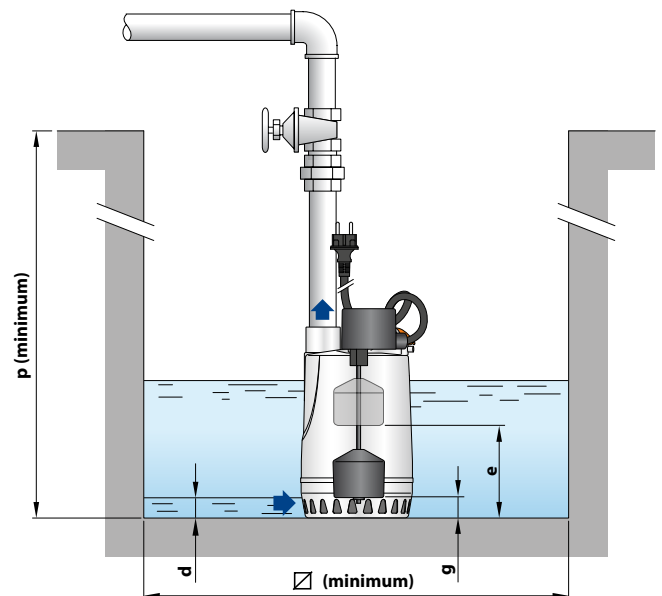
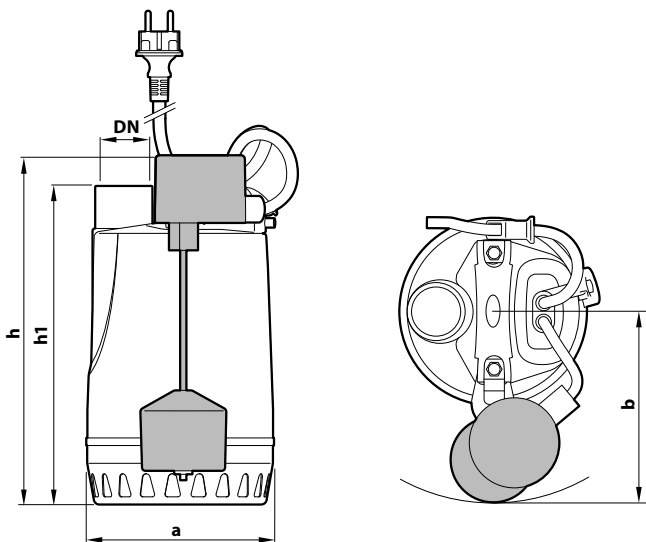

TYPE	PORT	DIMENSIONS mm									kg	PALLET CAPACITY
Single-phase	DN	a	b	h	h1	d	e	g (adjustable)	p	Ø	1~	
RXm 1-GM	1 1/4"	147	150	270	243	14	145	40	350	240	6.3	80
RXm 2-GM				300	273		175	45			6.3	80
RXm 3-GM				300	273		175	45			7.6	80

MATERIALS AND COMPONENTS

1 Outer sleeve	AISI 304 stainless steel with ISO 228/1 threaded port	
2 Suction filter	Stainless steel AISI 304	
3 Diffuser	Stainless steel AISI 304	
4 Impeller	Stainless steel AISI 304	
5 Motor sleeve	Stainless steel AISI 304	
6 Motor cover	Stainless steel AISI 304	
7 Motor shaft	Stainless steel AISI 431	
8 Double shaft seal with interposed oil chamber		
Seal	Shaft	Materials
STA-12R	Ø 12 mm	Ceramic / Graphite / NBR
Shaft seal	Ø 12 x Ø 19 x H 5 mm	
9 Capacitor (exclusive to single-phase models)		
10 Electric motor		
RXm: single-phase 230 V - 50 Hz with winding integrated thermal motor protection		
RX: three-phase 400 V - 50 Hz		
- Continuous running duty S1		
- Insulation: Class F		
- Protection rating IP X8		
11 Power cord		
Type 'H07 RN-F (Schuko plug exclusive to single-phase models)		
※ Standard length 5 metres		
12 Float switch (exclusive to single-phase models)		

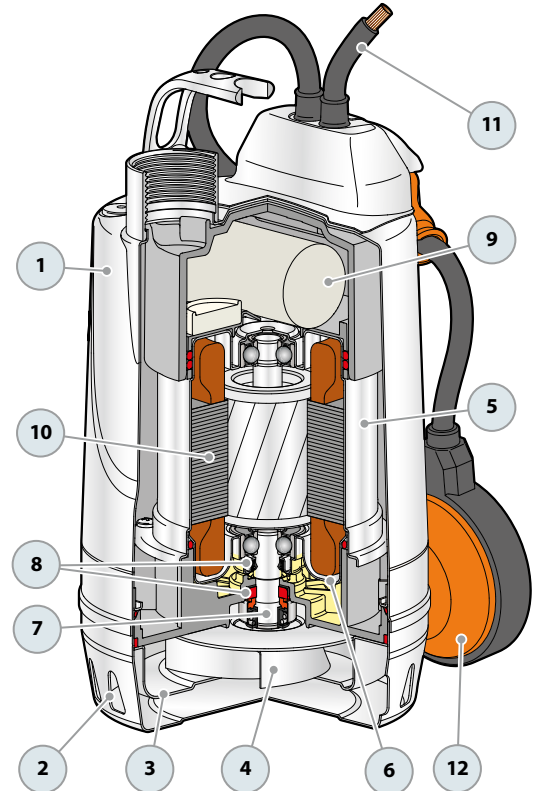

RX 4-5 Technical data

DIMENSIONS AND WEIGHT

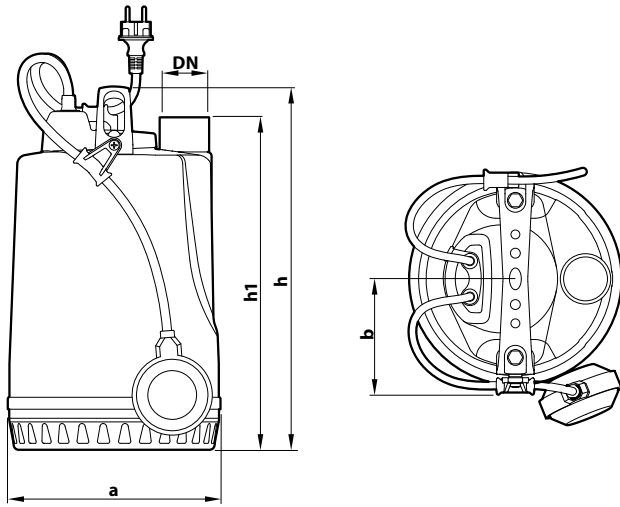

Typical installation

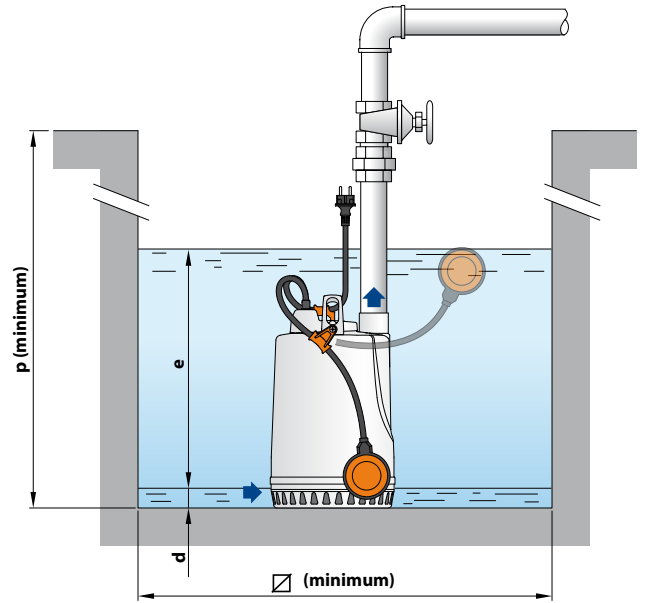

TYPE		PORT DN	DIMENSIONS mm								kg		PALLET CAPACITY
Single-phase	Three-phase		a	b	h	h1	d	e	p	Ø	1~	3~	
RXm 4	RX 4	1½"	220	118.5	368	336	25	adjustable	500	500	14.3	13.3	45
RXm 5	RX 5										15.5	14.4	

※ Version with 'GM' magnetic float switch

Typical installation

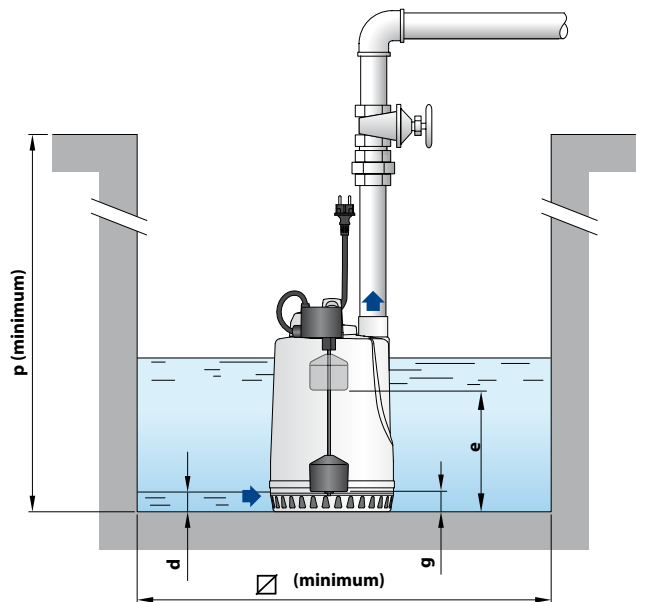
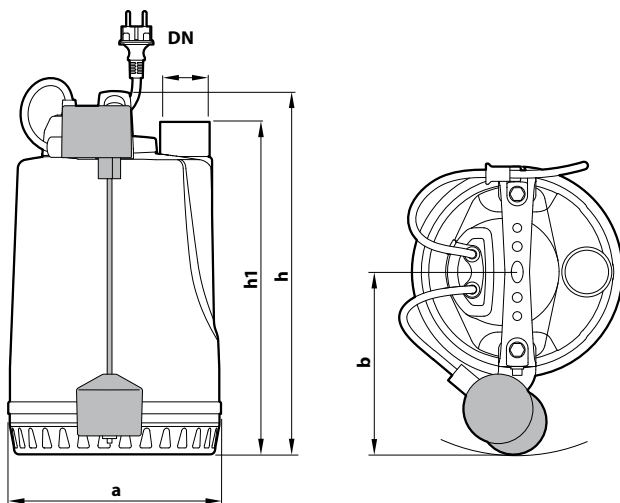

TYPE	PORT DN	DIMENSIONS mm									kg		PALLET CAPACITY
Single-phase	DN	a	b	h	h1	d	e	g (adjustable)	p	Ø	1~	3~	
RXm 4 - GM	1½"	220	186.5	368	336	25	250	50	500	300	14.5		36
RXm 5 - GM											15.6		36

MATERIALS AND COMPONENTS

1	Outer sleeve	AISI 304 stainless steel with ISO 228/1 threaded port		
2	Suction filter	Stainless steel AISI 304		
3	Diffuser	Stainless steel AISI 304		
4	Impeller	Stainless steel AISI 304		
5	Motor sleeve	Stainless steel AISI 304		
6	Motor cover	Stainless steel AISI 304		
7	Motor shaft	Stainless steel AISI 431		
8	Double mechanical seal with interposed oil chamber			
	Seal	Shaft	Location	Materials
	MG1-14D SIC	Ø 14 mm	Motor side Pump side	Silicon carbide / Graphite / NBR Silicon carbide/Silicon carbide/NBR

9 Capacitor
(exclusive to single-phase models)

10 Electric motor

RXm: single-phase 230 V - 50 Hz with winding integrated thermal motor protection
RX: three-phase 400 V - 50 Hz

- Continuous running duty S1
- Insulation: Class F
- Protection rating IP X8

11 Power cord

Type 'H07 RN-F
(Schuko plug exclusive to single-phase models)

※ Standard length 5 metres

12 Float switch
(exclusive to single-phase models)

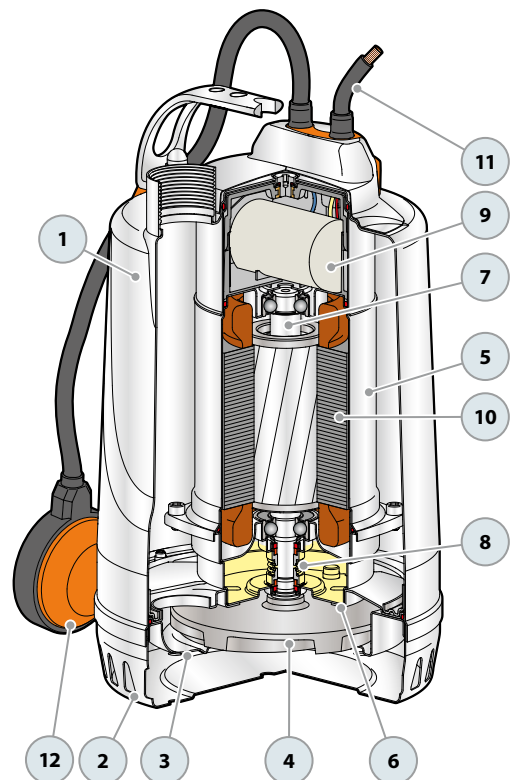

-  Dirty water
-  Domestic use
-  Civil use

※ All stainless steel pumps



PERFORMANCE RANGE

- Flow rate up to **380 l/min** (22.8 m³/h)
- Head up to **12.8 m**

INSTALLATION AND USE

RX-VORTEX pumps excel in draining **dirty water**, featuring designs that ensure reliable performance even during continuous operation, thanks to comprehensive motor cooling. Ideal for **domestic, civil, and industrial applications**, these pumps are perfect for removing dirty water containing suspended solids.

APPLICATION LIMITS

- Maximum operating depth below water level up to **10 m** (with an appropriately sized power cable)
- Liquid temperature up to **+50 °C** and up to **+90 °C** for short bursts (up to 3 minutes max) for intermittent service
- Suspended solids transfer:
 - up to **Ø 20 mm** for RX 2/20, RX 3/20
 - up to **Ø 40 mm** for RX 4/40, RX 5/40
- Draining capability:
 - up to **25 mm** from the bottom for RX 2/20, RX 3/20
 - up to **50 mm** from the bottom for RX 4/40, RX 5/40

PATENTS - TRADE MARKS - MODELS

- Patent No. EP2313658
- Patent No. IT0001428923

INCLUDES

- ※ Power cable length **5 m**
- ※ Float switch for single-phase versions

AVAILABLE UPON REQUEST

- ※ Mechanical seal options available
- ※ Pumps with **10 m** power cable.
- ※ Different voltage requirements 60 Hz frequency
- ※ **RX-VORTEX GM** pumps with magnetically operated float switch (suitable for small sumps)



CURVES AND PERFORMANCE DATA

50 Hz

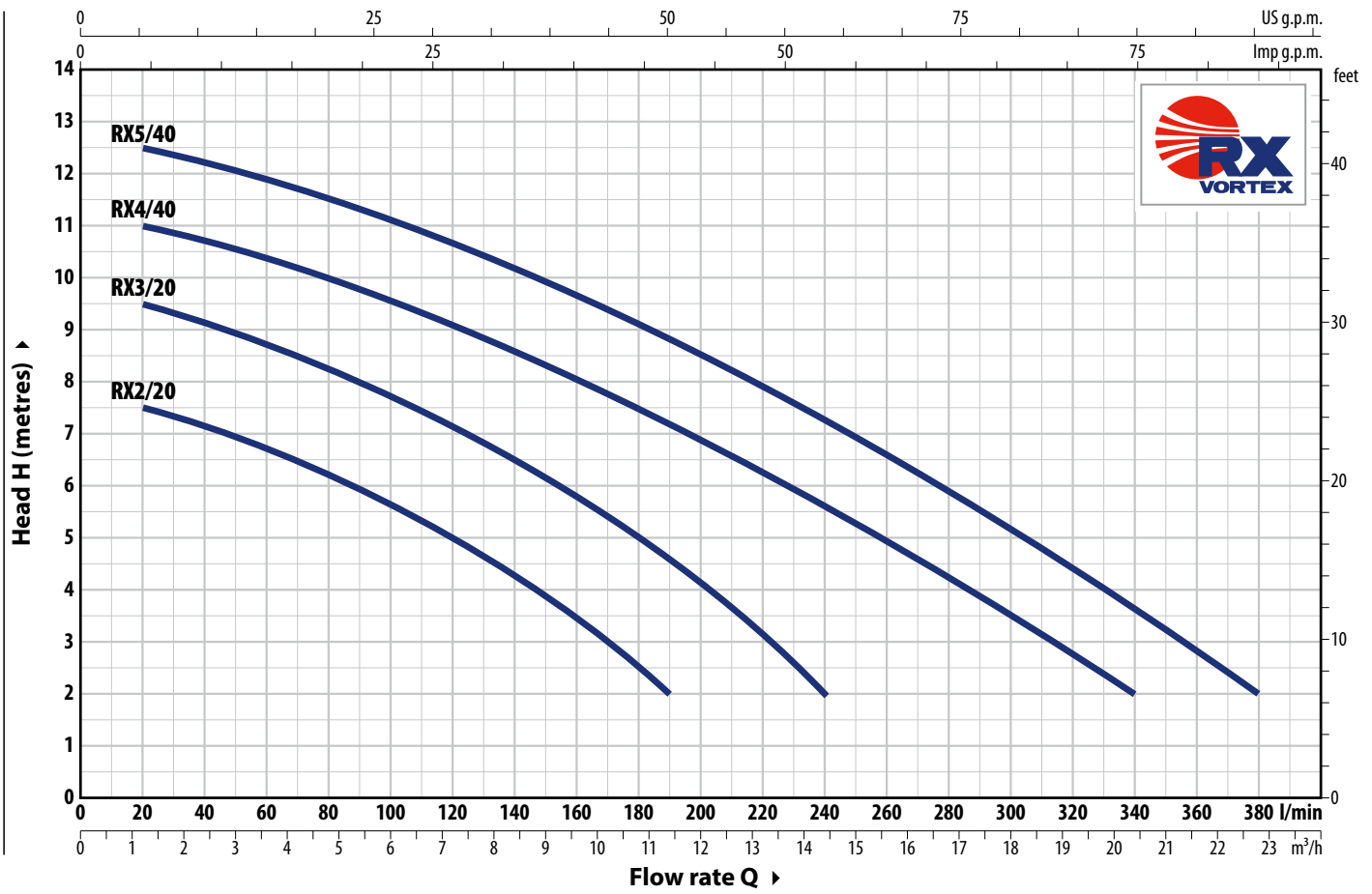

TYPE		POWER (P ₂)		Q	Flow rate (l/min)																
Single-phase	Three-phase	kW	HP		0	1.2	3.6	6.0	7.8	9.6	11.4	12.6	14.4	16.2	18.0	20.4	22.8				
RXm 2/20	RX 2/20	0.37	0.50	H metres	8	7.5	6.7	5.6	4.7	3.5	2										
RXm 3/20	RX 3/20	0.55	0.75		10	9.5	8.7	7.7	6.8	5.8	4.5	3.6	2								
RXm 4/40	RX 4/40	0.75	1		11.3	11	10.3	9.5	8.8	8	7.2	6.6	5.7	4.7	3.6	2					
RXm 5/40	RX 5/40	1.1	1.5		12.8	12.5	11.8	11	10.4	9.7	8.8	8.3	7.3	6.3	5.3	3.7	2				

Q = Flow rate H = Total manometric head

Performance curves comply with EN ISO 9906 Grade 3B tolerance limits.

ABSORPTION

TYPE	VOLTAGE
Single-phase	230 V
RXm 2/20	2.3 A
RXm 3/20	3.4 A
RXm 4/40	5.2 A
RXm 5/40	6.5 A

TYPE	VOLTAGE
Three-phase	400 V
RX 2/20	1.1 A
RX 3/20	1.5 A
RX 4/40	2.1 A
RX 5/40	3.1 A

DIMENSIONS AND WEIGHT

Typical installation

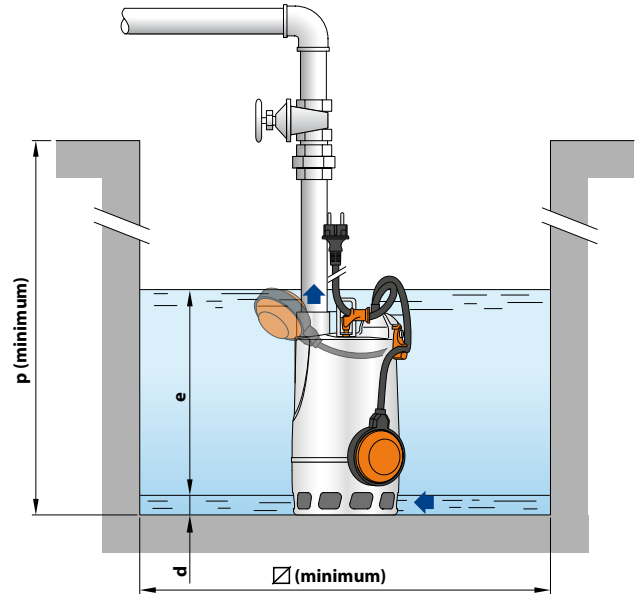
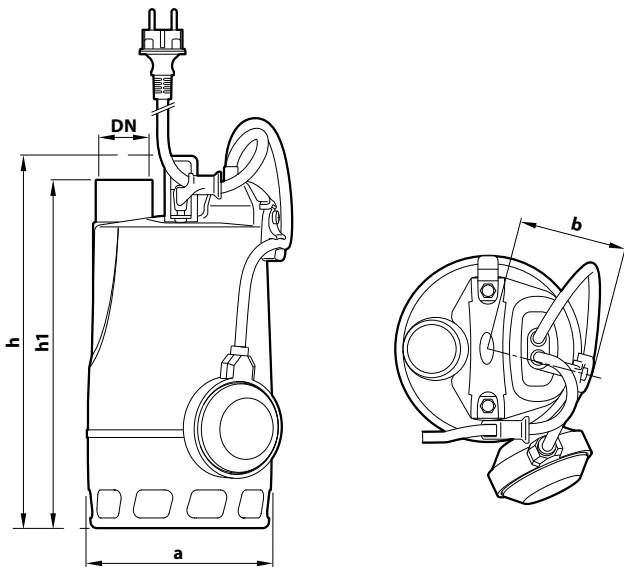

TYPE		PORT DN	DIMENSIONS mm								kg		PALLET CAPACITY
Single-ph.	Three-ph		a	b	h	h1	d	e	p	∅	1~	3~	
RXm 2/20	RX 2/20	1 1/4"	147	84	300	275	25	adjustable	350	350	6.2	5.8	96
RXm 3/20	RX 3/20				330	305					7.7	7.0	

※ Version with 'GM' magnetic float switch

Typical installation

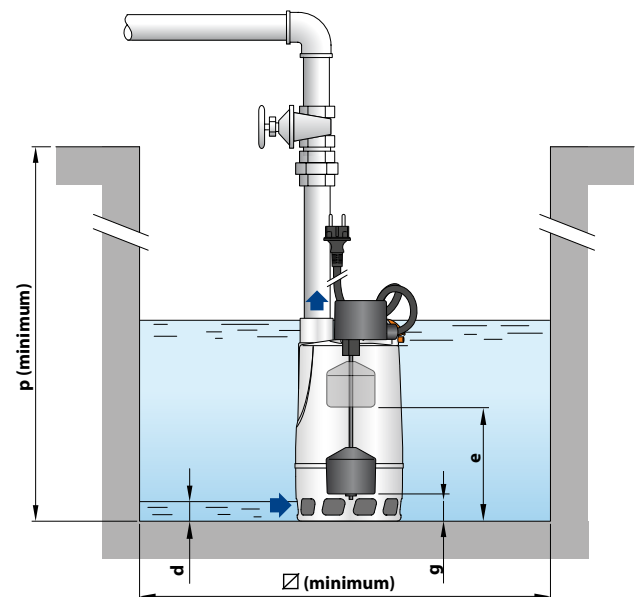
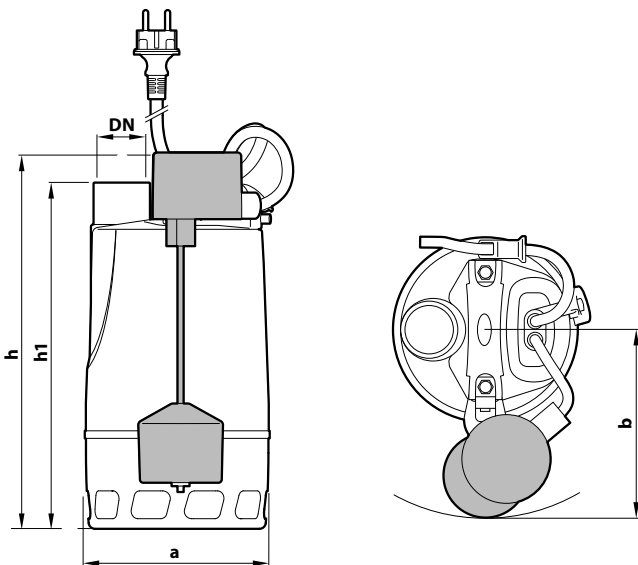

TYPE		PORT DN	DIMENSIONS mm								kg		PALLET CAPACITY
Single-phase			a	b	h	h1	d	e	g (adjustable)	p	∅	1~	
RXm 2/20-GM	1 1/4"	147	150	302	275	25	180	50	350	240	6.3	80	
RXm 3/20-GM				332	305		210	80			7.9		

MATERIALS AND COMPONENTS

1	Outer sleeve	AISI 304 stainless steel with ISO 228/1 threaded port
2	Suction filter	Stainless steel AISI 304
3	Diffuser	Stainless steel AISI 304
4	Impeller	VORTEX in AISI 304 stainless steel
5	Motor sleeve	Stainless steel AISI 304
6	Motor cover	Stainless steel AISI 304
7	Motor shaft	Stainless steel AISI 431
8	Double shaft seal with interposed oil chamber	
	Seal	Shaft
	STA-12R SIC	Ø 12 mm
		Materials
		Ceramic / Silicon carbide / NBR
	Shaft seal	Ø 12 x Ø 19 x H 5 mm

9 Capacitor
(exclusive to single-phase models)

10 Electric motor

- RXm:** single-phase 230 V - 50 Hz with winding integrated thermal motor protection
RX: three-phase 400 V - 50 Hz
 – Continuous running duty S1
 – Insulation: Class F
 – Protection rating IP X8

11 Power cord

- Type 'H07 RN-F'
 (Schuko plug exclusive to single-phase models)
 ※ Standard length 5 metres

12 Float switch

- (exclusive to single-phase models)

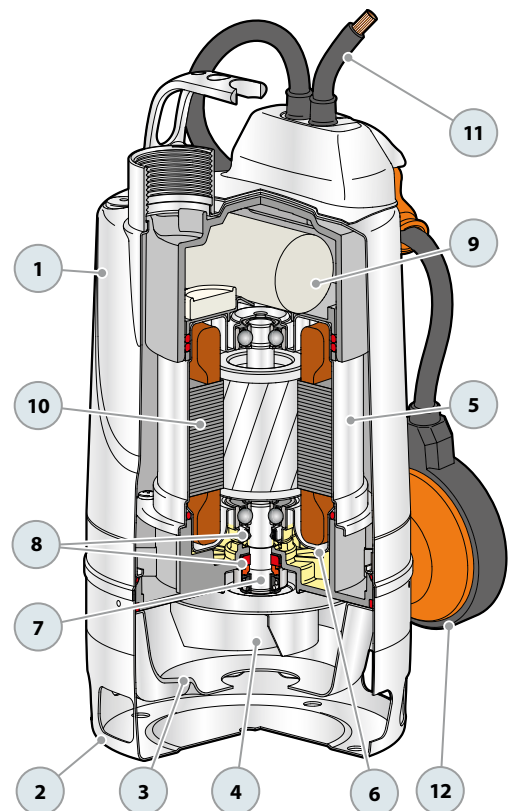

DIMENSIONS AND WEIGHT

Typical installation

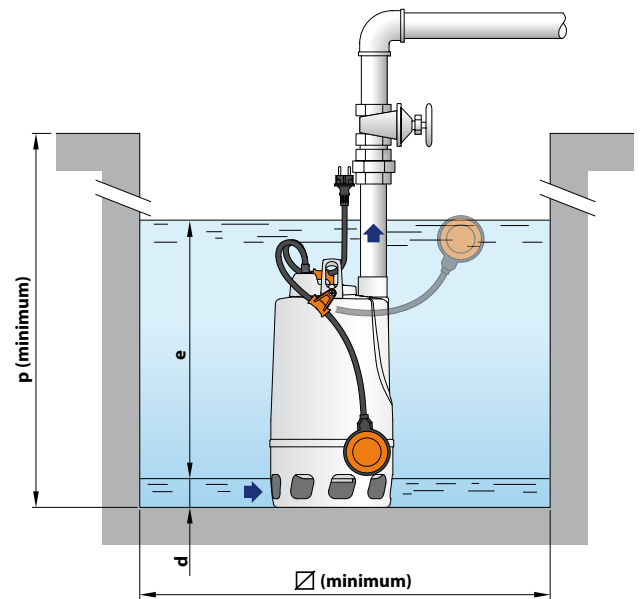
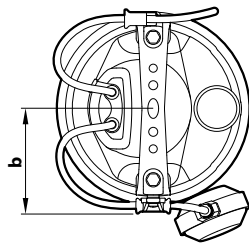
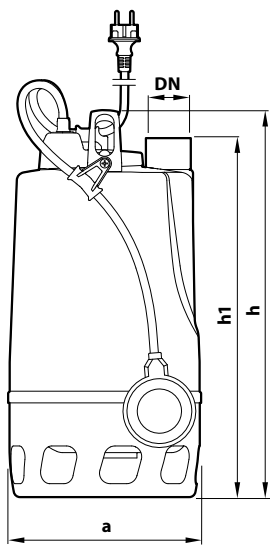

TYPE		PORT DN	DIMENSIONS mm								kg		PALLET CAPACITY
Single-phase	Three-phase		a	b	h	h1	d	e	p	∅	1~	3~	
RXm 4/40	RX 4/40	1½"	215	115	432	400	50	adjustable	500	500	14.8	13.9	45
RXm 5/40	RX 5/40										16.0	14.8	45

※ Version with 'GM' magnetic float switch

Typical installation

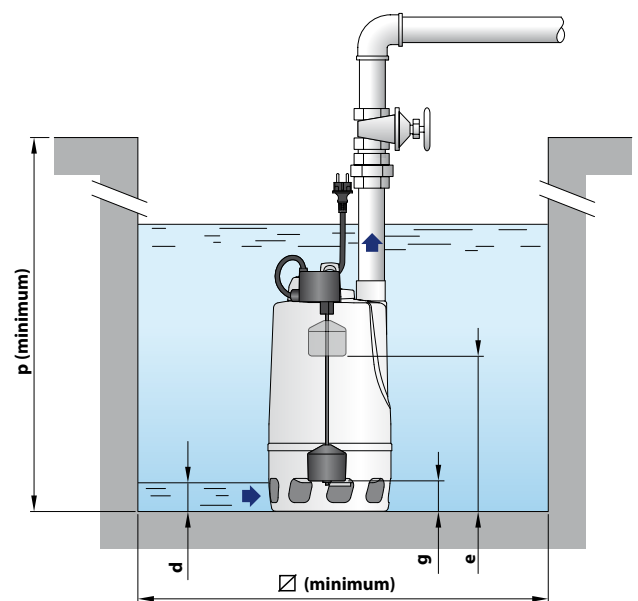
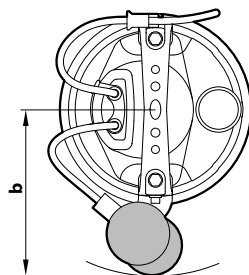
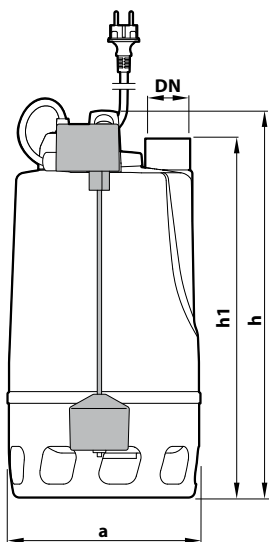

TYPE		PORT DN	DIMENSIONS mm								kg		PALLET CAPACITY
Single-phase			a	b	h	h1	d	e	g (adjustable)	p	∅	1~	
RXm 4/40 - GM		1½"	215	186.5	432	400	50	320	80	500	350	15.2	36
RXm 5/40 - GM												16.2	36

MATERIALS AND COMPONENTS

1 Outer sleeve AISI 304 stainless steel with ISO 228/1 threaded port

2 Suction filter Stainless steel **AISI 304**

3 Diffuser Stainless steel **AISI 304**

4 Impeller VORTEX in **AISI 304** stainless steel

5 Motor sleeve Stainless steel **AISI 304**

6 Motor cover Stainless steel **AISI 304**

7 Motor shaft Stainless steel **AISI 431**

8 Double mechanical seal with interposed oil chamber

Seal	Shaft	Location	Materials
MG1-14D SIC Ø 14 mm		Motor side	Silicon carbide / Graphite / NBR
		Pump side	Silicon carbide/Silicon carbide/NBR

9 Capacitor
(exclusive to single-phase models)

10 Electric motor

RXm: single-phase 230 V - 50 Hz with winding integrated thermal motor protection

RX: three-phase 400 V - 50 Hz

- Continuous running duty S1
- Insulation: Class F
- Protection rating IP X8

11 Power cord

Type 'H07 RN-F
(Schuko plug exclusive to single-phase models)
※ Standard length 5 metres

12 Float switch
(exclusive to single-phase models)

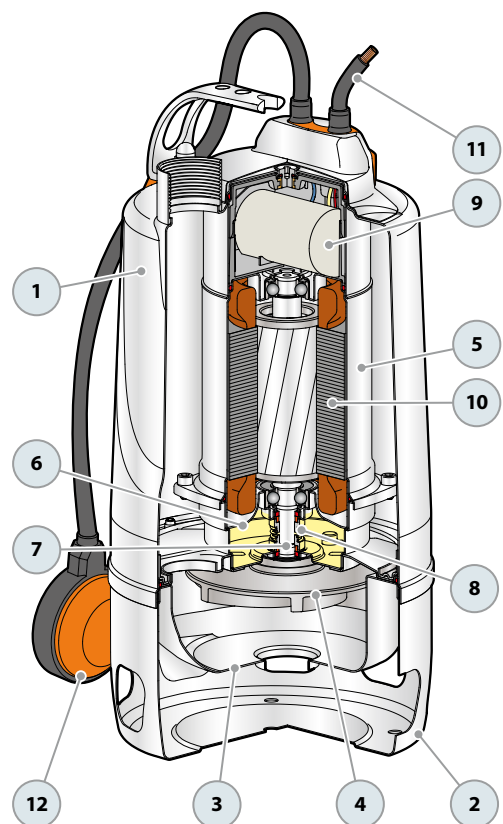

-  Sewage
-  Domestic use
-  Civil use
-  Industrial use

※ **Powerful and robust high-efficiency pumps made entirely of stainless steel**



※ **VX-ST constructed entirely from stainless steel, VX-ST submersible pumps offer superior corrosion and abrasion.**

PERFORMANCE RANGE

- Flow rate up to **700 l/min** (42 m³/h)
- Head up to **17 m**

INSTALLATION AND USE

VX-ST stainless steel submersible pumps are designed for sewage drainage in **domestic, civil, and industrial** settings where suspended solids are present in the water, such as sludge-mixed water, groundwater, or surface water.

They are also perfect for pumping out flooded areas like basements, underground parking garages, car wash stations, and emptying septic tanks and sewage systems.

- ※ The hydraulic configuration of the **VORTEX** volute and impeller results from advanced fluid dynamics calculations, delivering superior performance and efficiency for notable energy savings.
- ※ The **VORTEX** impeller can handle solids up to **50 mm** in diameter. Its unique design ensures safe operation against clogging.

INCLUDES

- ※ Power cable length **10 m**
- ※ Float switch (exclusive to single-phase models)

APPLICATION LIMITS

- Depth below water level up to **5 m** (with an appropriately sized power cable)
- Liquid temperature up to **+40 °C**
- Suspended solids transfer:
 - up to **Ø 40 mm** for VX /35-ST
 - up to **Ø 50 mm** for VX /50-ST
- **Minimum immersion for continuous service:**
 - **290 mm** for VX 8-ST and VX 10-ST
 - **330 mm** for VX 15-ST
 - **360 mm** for VX 20-ST

AVAILABLE UPON REQUEST

- ※ AISI 316L stainless steel pump shaft
- ※ Different voltage requirements 60 Hz frequency

PATENTS - TRADE MARKS - MODELS

- Patent No. EP2313658
- Patent No. IT0001428923

CURVES AND PERFORMANCE DATA

50 Hz

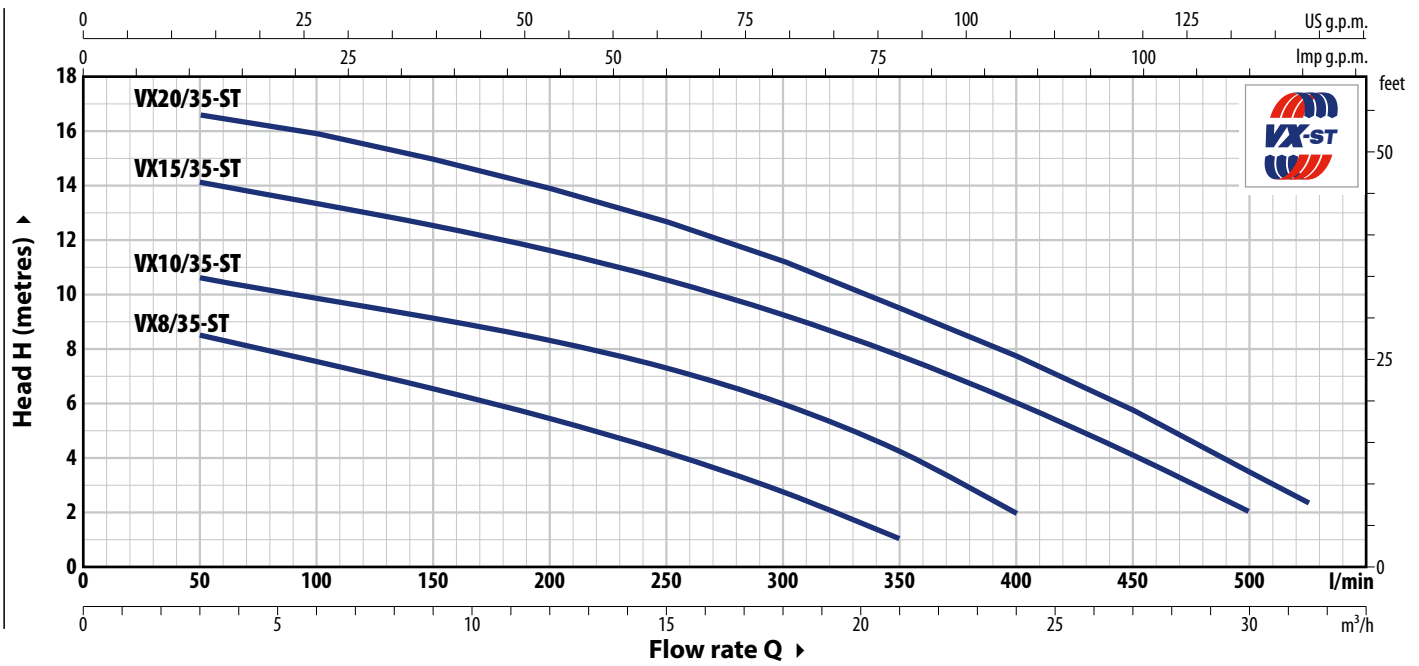

TYPE		POWER (P ₂)		Q	H metres													
Single-phase	Three-phase	kW	HP		m ³ /h	0	3	6	12	18	21	24	27	30	31.5			
VXm 8/35 -ST	VX 8/35 -ST	0.55	0.75	l/min	0	50	100	200	300	350	400	450	500	525				
VXm 10/35-ST	VX 10/35-ST	0.75	1		9.5	8.5	7.5	5.4	2.7	1								
VXm 15/35-ST	VX 15/35-ST	1.1	1.5		11.5	10.5	10	8.3	6	4	2							
VXm 20/35-ST	VX 20/35-ST	1.5	2		15	14	13.5	11.7	9.2	7.7	6	4	2					
					17	16.5	16	14	11	9.5	7.7	5.7	3.5	2.5				

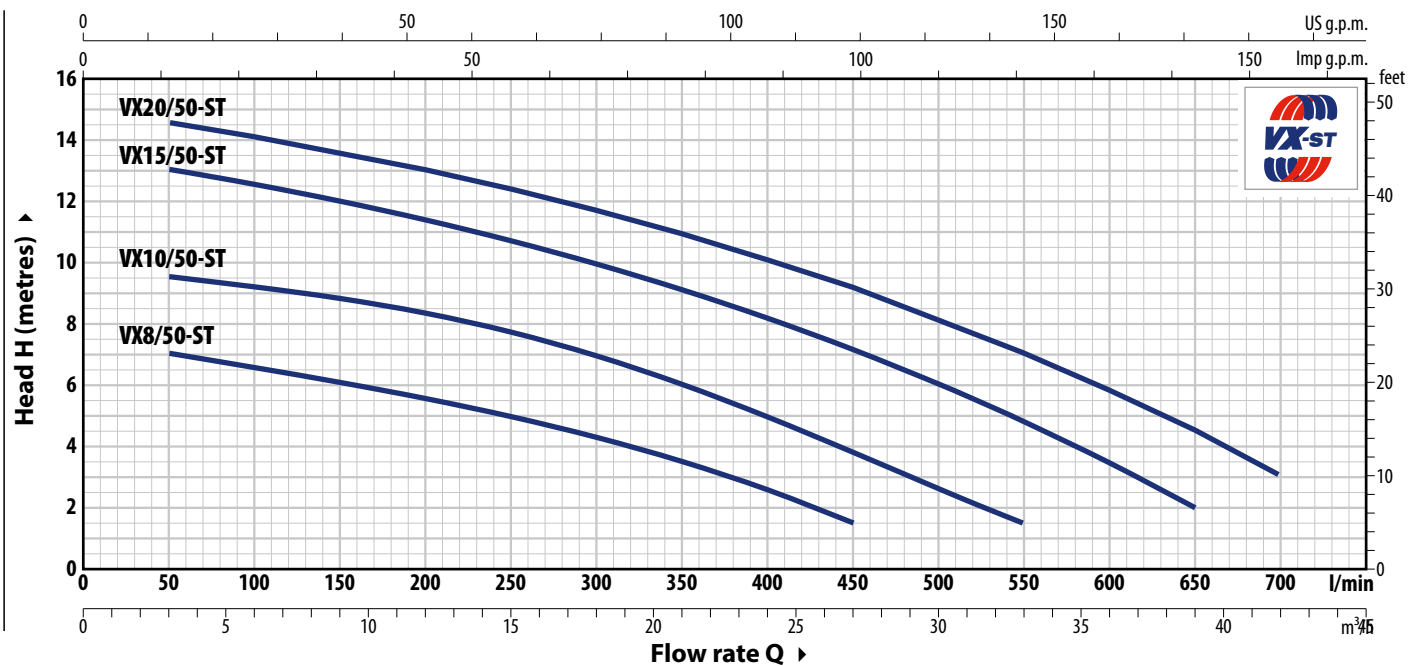

TYPE		POWER (P ₂)		Q	H metres													
Single-phase	Three-phase	kW	HP		m ³ /h	0	3	6	12	18	24	27	30	33	36	39	42	
VXm 8/50 -ST	VX 8/50 -ST	0.55	0.75	l/min	0	50	100	200	300	400	450	500	550	600	650	700		
VXm 10/50-ST	VX 10/50-ST	0.75	1		7.5	7	6.6	5.7	4.2	2.5	1.5							
VXm 15/50-ST	VX 15/50-ST	1.1	1.5		10	9.5	9.2	8.5	7	5	3.8	2.7	1.5					
VXm 20/50-ST	VX 20/50-ST	1.5	2		13.5	13	12.5	11.5	10	8	7	6	4.7	3.3	2			
					15	14.5	14	13	11.7	10	9	8.2	7	5.8	4.5	3		

Q = Flow rate H = Total manometric head

Performance curves comply with EN ISO 9906 Grade 3B tolerance limits.

ABSORPTION

TYPE	VOLTAGE
Single-phase	230 V
VXm 8/35 -ST	4.3 A
VXm 10/35 -ST	5.5 A
VXm 15/35 -ST	7.0 A
VXm 20/35 -ST	9.6 A
VXm 8/50 -ST	4.3 A
VXm 10/50 -ST	5.5 A
VXm 15/50 -ST	7.0 A
VXm 20/50 -ST	9.6 A

TYPE	VOLTAGE
Three-phase	400 V
VX 8/35 -ST	1.6 A
VX 10/35 -ST	2.2 A
VX 15/35 -ST	2.7 A
VX 20/35 -ST	3.7 A
VX 8/50 -ST	1.6 A
VX 10/50 -ST	2.2 A
VX 15/50 -ST	2.7 A
VX 20/50 -ST	3.7 A

DIMENSIONS AND WEIGHT

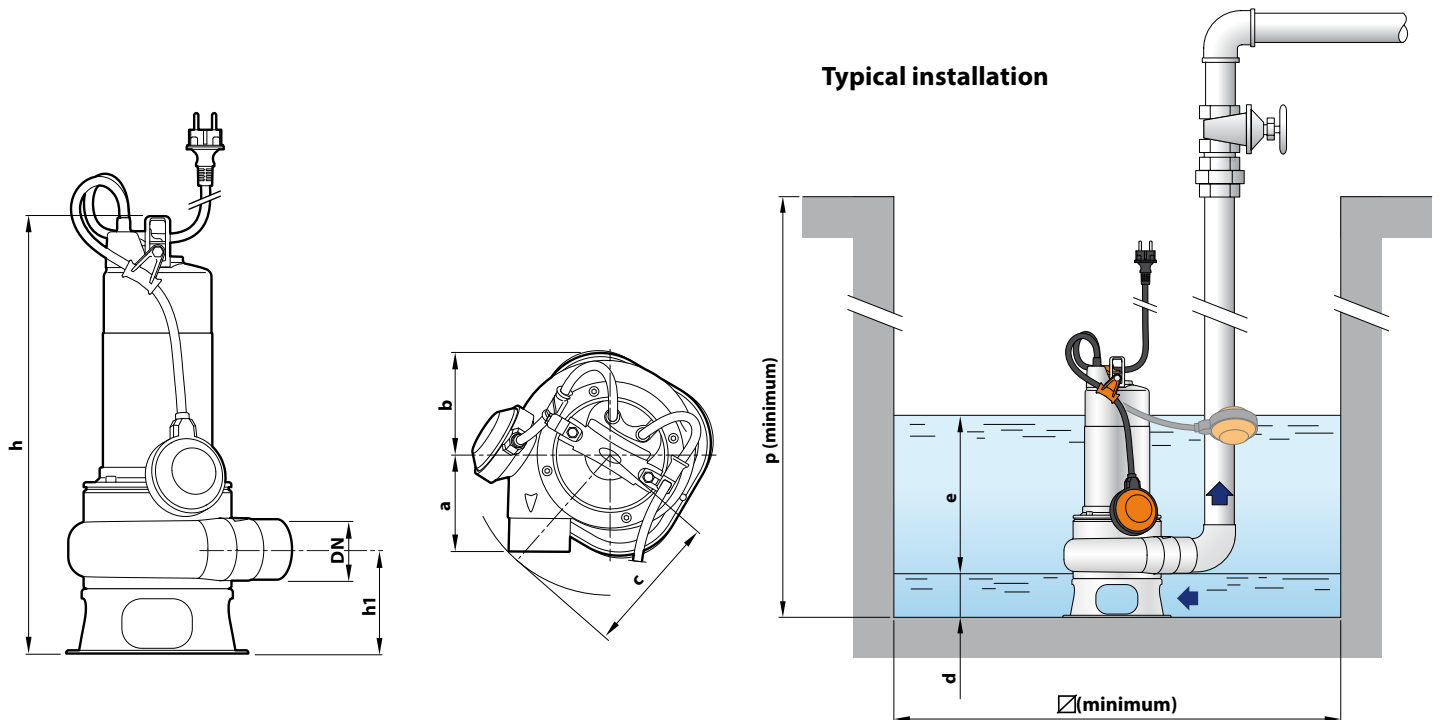

TYPE		PORT DN	Passage of solid bodies	DIMENSIONS mm										kg	
Single-phase	Three-phase			a	b	c	h	h1	d	e	p	∅	1~	3~	
VXm 8/35 -ST	VX 8/35 -ST	1½"	∅ 40 mm	95	96	140	424	106	55	adjustable	500	500	11.2	10.1	
VXm 10/35 -ST	VX 10/35 -ST						439						12.7	11.5	
VXm 15/35 -ST	VX 15/35 -ST						472						15.5	13.9	
VXm 20/35 -ST	VX 20/35 -ST						502						17.7	15.5	
VXm 8/50 -ST	VX 8/50 -ST	2"	∅ 50 mm	102	96	145	435	107	60	adjustable	500	500	11.4	10.3	
VXm 10/50 -ST	VX 10/50 -ST						450						12.9	11.7	
VXm 15/50 -ST	VX 15/50 -ST						483						15.7	14.1	
VXm 20/50 -ST	VX 20/50 -ST						513						17.9	15.7	

PALLET CAPACITY

TYPE		NO. OF PUMPS
Single-phase	Three-phase	
VXm 8/35 -ST	VX 8/35 -ST	45
VXm 10/35 -ST	VX 10/35 -ST	45
VXm 15/35 -ST	VX 15/35 -ST	30
VXm 20/35 -ST	VX 20/35 -ST	30
VXm 8/50 -ST	VX 8/50 -ST	45
VXm 10/50 -ST	VX 10/50 -ST	45
VXm 15/50 -ST	VX 15/50 -ST	30
VXm 20/50 -ST	VX 20/50 -ST	30

MATERIALS AND COMPONENTS

1 Pump body	AISI 304 stainless steel with ISO 228/1 threaded port		
2 Base	Stainless steel AISI 304		
3 Impeller	VORTEX type in AISI 304 stainless steel		
4 Motor sleeve	Stainless steel AISI 304		
5 Motor cover	Stainless steel AISI 304 Cast iron with cataphoresis treatment for VX 15-20 ST		
6 Motor shaft	Stainless steel AISI 431		
7 Double mechanical seal in oil chamber			
Seal	Shaft	Location	Materials
MG1-14D SIC	Ø 14 mm	Motor side Pump side	Silicon carbide / Graphite / NBR Silicon carbide/Silicon carbide/NBR
8 Capacitor (exclusive to single-phase models)			
9 Electric motor			
VXm-ST: single-phase 230 V - 50 Hz with winding integrated thermal motor protection			
VX-ST: three-phase 400 V - 50 Hz			
- Insulation: class F			
- Protection rating: IP X8			
10 Power cord			
Power cable encapsulated with epoxy resin both in the grommet area and where the conductors exit the sheath, for absolute insulation against moisture and water.			
Type 'H07 RN-F' (Schuko plug exclusive to single-phase models)			
※ Standard length 10 metres			
11 Float switch (exclusive to single-phase models)			
12 Tilting device for the float cable (exclusive to single-phase models) Patent No. IT0001428923			
13 Power cable strain relief Patent No. EP2313658			

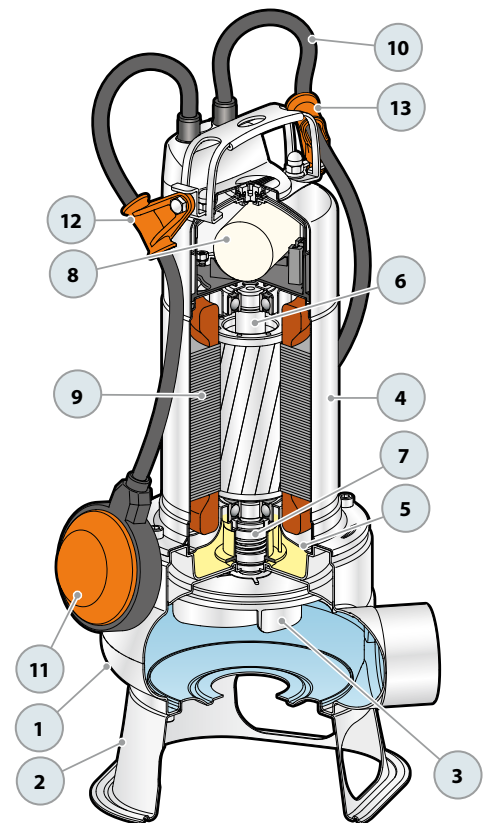

-  Sewage
-  Domestic use
-  Civil use
-  Industrial use

※ **Powerful and robust high-efficiency pumps made entirely of stainless steel**



※ **Constructed entirely from stainless steel, BC-ST submersible pumps offer superior corrosion and abrasion.**

PERFORMANCE RANGE

- Flow rate up to **850 l/min** (51 m³/h)
- Head up to **17 m**

INSTALLATION AND USE

BC-ST stainless steel submersible pumps are designed to drain dirty and **sewage water** in **domestic, civil, and industrial settings**. Featuring a **TWO-CHANNEL** impeller, they can efficiently pump liquids containing suspended solids up to 50 mm in diameter with short fibers and handle wastewater, sewage, surface water, and sludge-mixed water in residential properties.

※ The hydraulic configuration of the volute and **TWO-CHANNEL** impeller results from advanced fluid dynamics calculations, delivering superior performance and efficiency for notable energy savings.

※ The **TWO-CHANNEL** impeller provides excellent performance and high energy efficiency, generating increased pressure for pumping solids up to **50 mm** in diameter, making it the best choice for wastewater drainage.

INCLUDES

- ※ Power cable length **10 m**
- ※ Float switch (exclusive to single-phase models)

APPLICATION LIMITS

- Depth below water level up to **5 m** (with an appropriately sized power cable)
- Liquid temperature up to **+40 °C**
- Capable of processing suspended solids up to **Ø 50 mm**
- **Minimum immersion for continuous service:**
 - **290 mm for BC 10/50-ST**
 - **330 mm for BC 15/50-ST**
 - **360 mm for BC 20/50-ST**

AVAILABLE UPON REQUEST

- ※ AISI 316L stainless steel pump shaft
- ※ Different voltage requirements 60 Hz frequency

PATENTS - TRADE MARKS - MODELS

- Patent No. EP2313658
- Patent No. IT0001428923

CURVES AND PERFORMANCE DATA

50 Hz

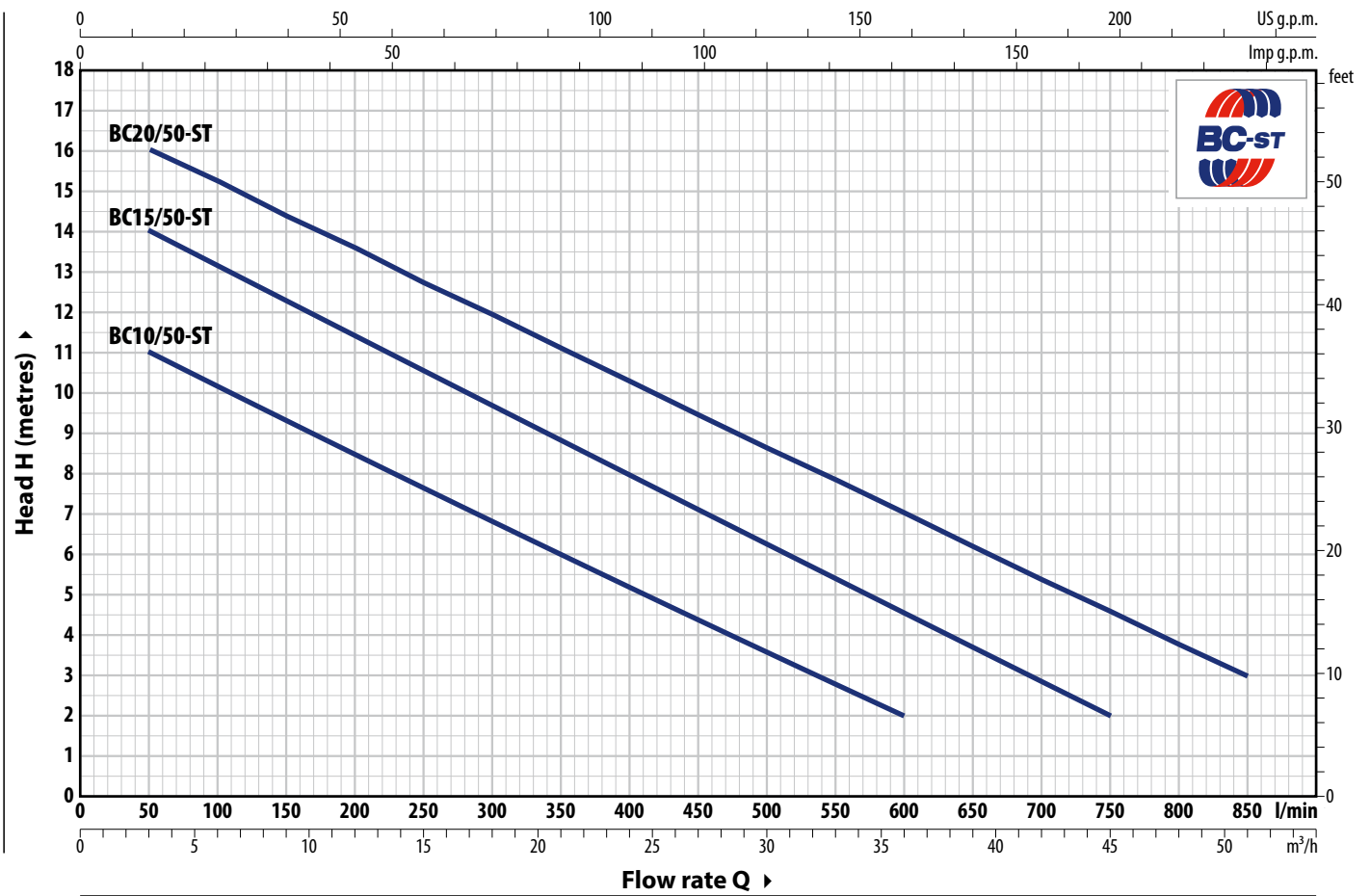

TYPE		POWER (P ₂)		Q	Flow rate														
Single-phase	Three-phase	kW	HP		m ³ /h	0	3	6	12	18	24	30	36	42	45	51			
					0	50	100	200	300	400	500	600	700	750	850				
BCm 10/50-ST	BC 10/50-ST	0.75	1	H metres	12	11	10	8.5	7	5	3.6	2							
BCm 15/50-ST	BC 15/50-ST	1.1	1.5		15	14	13	11.5	9.7	8	6.3	4.6	3	2					
BCm 20/50-ST	BC 20/50-ST	1.5	2		17	16	15.3	13.5	12	10.3	8.6	7	5.3	4.5	3				

Q = Flow rate H = Total manometric head

Performance curves comply with EN ISO 9906 Grade 3B tolerance limits.

ABSORPTION

TYPE	VOLTAGE
Single-phase	230 V
BCm 10/50-ST	5.5 A
BCm 15/50-ST	8.0 A
BCm 20/50-ST	10.0 A

TYPE	VOLTAGE
Three-phase	400 V
BC 10/50-ST	2.2 A
BC 15/50-ST	3.1 A
BC 20/50-ST	3.9 A

DIMENSIONS AND WEIGHT

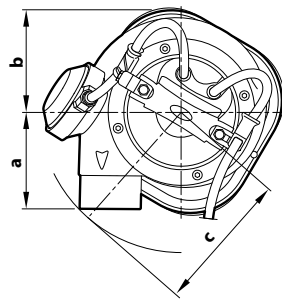
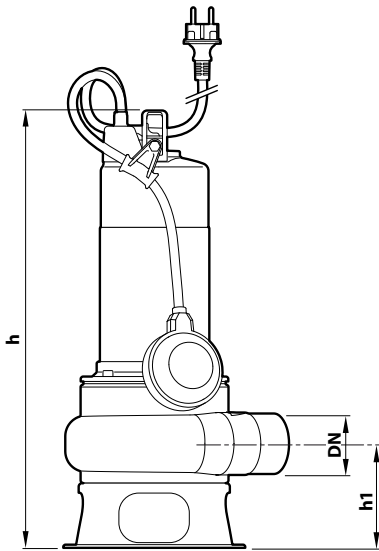

Typical installation

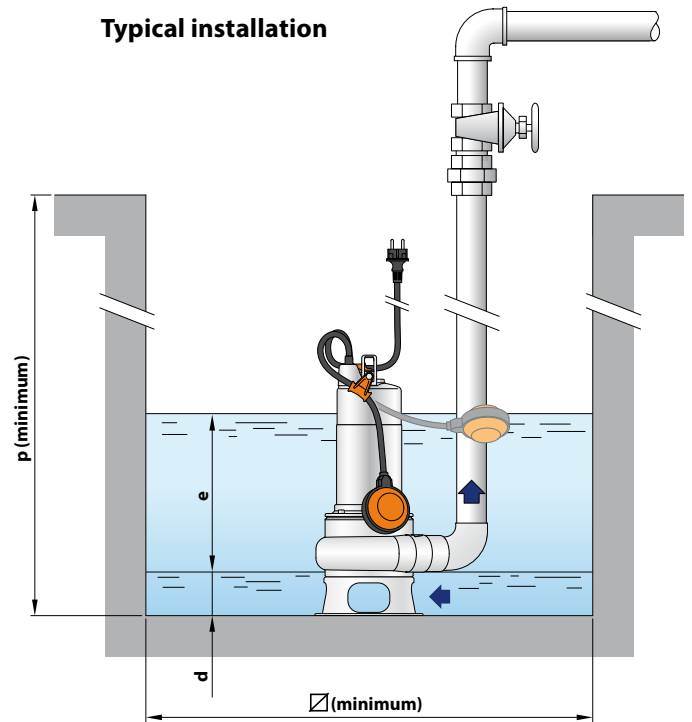

TYPE		PORT DN	Passage of solid bodies	DIMENSIONS mm									kg	
Single-phase	Three-phase			a	b	c	h	h1	d	e	p	\varnothing	1~	3~
BCm 10/50-ST	BC 10/50-ST	2"	$\varnothing 50$ mm	102	95	145	450	107	60	adjustable	500	500	13.4	12.2
BCm 15/50-ST	BC 15/50-ST						483						16.0	14.4
BCm 20/50-ST	BC 20/50-ST						513						18.2	16.0

PALLET CAPACITY

TYPE		NO. OF PUMPS
Single-phase	Three-phase	
BCm 10/50-ST	BC 10/50-ST	45
BCm 15/50-ST	BC 15/50-ST	30
BCm 20/50-ST	BC 20/50-ST	30

MATERIALS AND COMPONENTS

1 Pump body	AISI 304 stainless steel with ISO 228/1 threaded port		
2 Base	Stainless steel AISI 304		
3 Impeller	TWO-CHANNEL type in micro-cast AISI 304 stainless steel.		
4 Motor sleeve	Stainless steel AISI 304		
5 Motor cover	AISI 304 stainless steel for BC 10/50-ST Cast iron with cathoresis treatment for BC 15/50-ST, BC 20/50-ST		
6 Motor shaft	Stainless steel AISI 431		
7 Double mechanical seal in oil chamber			
Seal	Shaft	Location	Materials
MG1-14D SIC	Ø 14 mm	Motor side Pump side	Silicon carbide / Graphite / NBR Silicon carbide/Silicon carbide/NBR
8 Capacitor (exclusive to single-phase models)			
9 Electric motor			
BCm-ST:	single-phase 230 V - 50 Hz with winding integrated thermal motor protection		
BC-ST:	three-phase 400 V - 50 Hz		
	– Insulation: class F		
	– Protection rating: IP X8		
10 Power cord			
	Power cable encapsulated with epoxy resin both in the grommet area and where the conductors exit the sheath, for absolute insulation against moisture and water.		
	Type 'H07 RN-F' (Schuko plug exclusive to single-phase models)		
	※ Standard length 10 metres		
11 Float switch (exclusive to single-phase models)			
12 Tilting device for the float cable (exclusive to single-phase models)	Patent No. IT0001428923		
13 Power cable strain relief Patent No. EP2313658			

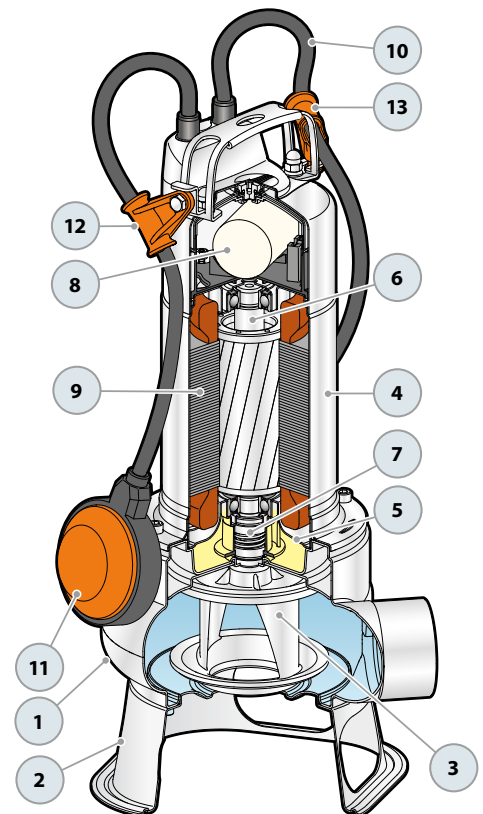

SEWAGE LIFTING SYSTEM KIT VX-ST - BC-ST

VERSION WITH HORIZONTAL DELIVERY AND 3/4" GUIDE PIPES

For VX /35-ST	CODE ASSPVX35ST	DN 2"
For VX /50-ST , BC /50-ST	CODE ASSPVX50ST	DN 2"

※ Kit consisting of:



Coupling foot



Solids rail with ring nut and seal



Support for guide tubes



VERSION WITH VERTICAL DELIVERY AND 3/4" GUIDE PIPES

For VX /35-ST	CODE ASSPVX35STV	DN 2½"
For VX /50-ST, BC /50-ST	CODE ASSPVX50STV	DN 2½"

※ Kit consisting of:



Coupling foot complete with counterflange



Solids rail with ring nut and seal



Support for guide tubes



● ACCESSORIES AVAILABLE FOR ORDER

RUNNING GUIDE

※ For VX /35-ST	CODE ASSFL005
※ For VX /50-ST , BC /50-ST	CODE ASSFL006

Complete with ring nut and gasket

GUIDE TUBE SUPPORT

※ For Ø 3/4 " guide tubes	CODE 859SV340INTFA
---------------------------	--------------------

To ensure stability, insert a support every 2 metres along the guide tube

GUIDE TUBE (AISI 304 stainless steel)

※ 2 metres Ø 3/4" guide tube	CODE 54SARTG0052F
※ 3 metres Ø 3/4" guide tube	CODE 54SARTG0053F
※ 6 metres Ø 3/4" guide tube	CODE 54SARTG0056F



DIMENSIONS (Version with horizontal outlet)

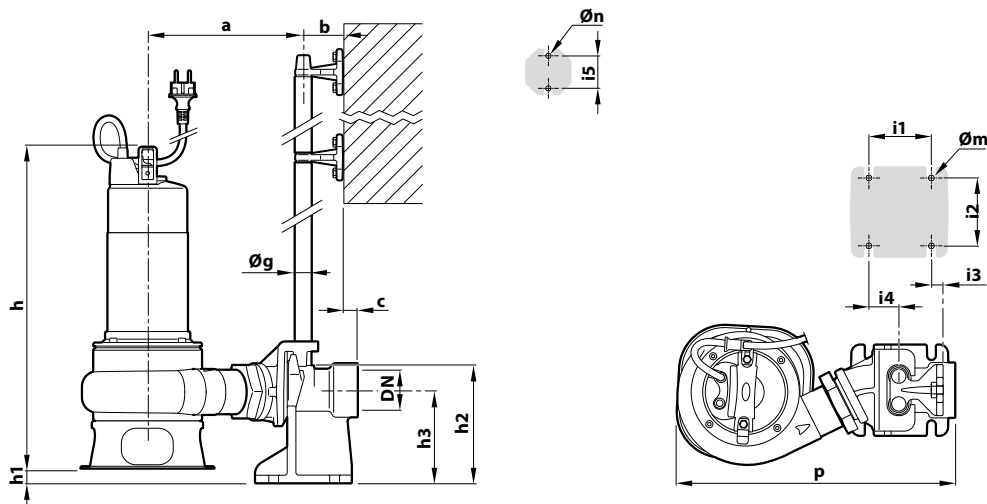

TYPE		Passage of solid bodies mm	PORT DN	DIMENSIONS mm															
Single-ph.	Three-ph.			a	b	c	p	h	h1	h2	h3	i1	i2	i3	i4	i5	Øg	Øm	Øn
VXm 8/35 -ST	VX 8/35 -ST	40	2"	214			386	424	24										
VXm 10/35 -ST	VX 10/35 -ST							439											
VXm 15/35 -ST	VX 15/35 -ST							472											
VXm 20/35 -ST	VX 20/35 -ST							502											
VXm 8/50 -ST	VX 8/50 -ST	50	2"	221	61	17	372	435	165	130	85	94	16	40	50	¾"	12	11	
VXm 10/50 -ST	VX 10/50 -ST							450											
VXm 15/50 -ST	VX 15/50 -ST							483											
VXm 20/50 -ST	VX 20/50 -ST							513											
BCm 10/50 -ST	BC 10/50 -ST	50	2"					450											
BCm 15/50 -ST	BC 15/50 -ST							483											
BCm 20/50 -ST	BC 20/50 -ST							513											

DIMENSIONS (Version with vertical delivery)

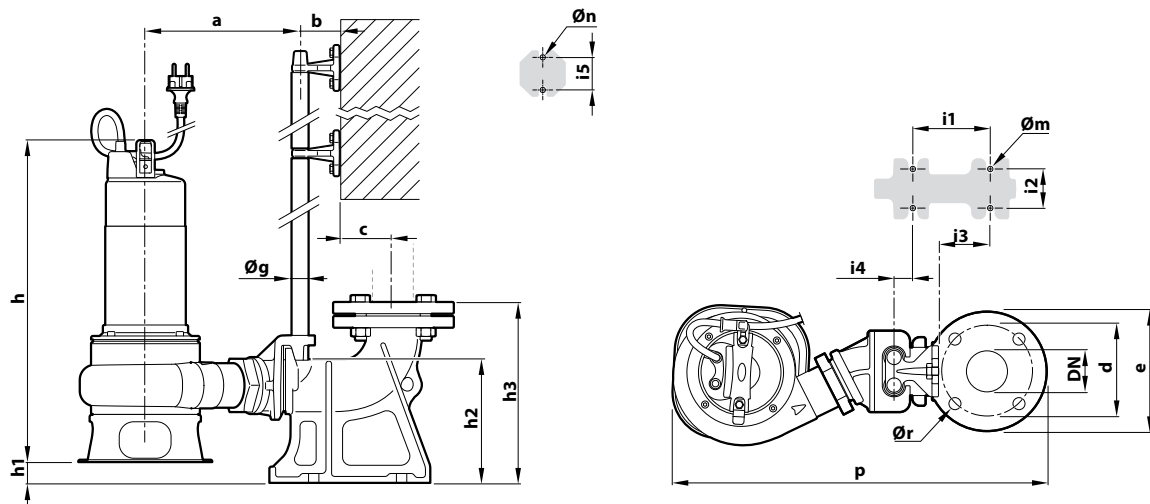

TYPE		Passage of solid bodies mm	PORT DN	DIMENSIONS mm																
Single-ph.	Three-ph.			a	b	c	d	e	p	h	h1	h2	h3	i1	i2	i3	i4	i5	Øg	Øm
VXm 8/35 -ST	VX 8/35 -ST	40	2½"	207				495	424	22										
VXm 10/35 -ST	VX 10/35 -ST								439											
VXm 15/35 -ST	VX 15/35 -ST								472											
VXm 20/35 -ST	VX 20/35 -ST								502											
VXm 8/50 -ST	VX 8/50 -ST	50	2½"	212	61	52	125	165	435	164	215	120	72	62	3	50	¾"	14	11	18
VXm 10/50 -ST	VX 10/50 -ST								450											
VXm 15/50 -ST	VX 15/50 -ST								483											
VXm 20/50 -ST	VX 20/50 -ST								513											
BCm 10/50 -ST	BC 10/50 -ST	50	2½"					501	450											
BCm 15/50 -ST	BC 15/50 -ST								483											
BCm 20/50 -ST	BC 20/50 -ST								513											

-  Sewage
-  Domestic use
-  Civil use
-  Industrial use

※ They are recommended when a pump of high efficiency, quality and durability is required



※ Constructed entirely from stainless steel, VX-MF submersible pumps offer superior corrosion and abrasion.

PERFORMANCE RANGE

- Flow rate up to **750 l/min** (45 m³/h)
- Head up to **15.5 m**

INSTALLATION AND USE

The **VX-MF** micro-cast stainless steel submersible pumps are designed for demanding working conditions, ideal for sewage drainage in **domestic, civil, and industrial settings** where suspended solids are present, such as water mixed with sludge, groundwater, or surface water. such as sludge-mixed water, groundwater, or surface water.

They are also perfect for pumping out flooded areas like basements, underground parking garages, car wash stations, and emptying septic tanks and sewage systems.

※ The hydraulic configuration of the **VORTEX** volute and impeller results from advanced fluid dynamics calculations, delivering superior performance and efficiency for notable energy savings.

※ The **VORTEX** impeller can handle solids up to **50 mm** in diameter. Its unique design ensures safe operation against clogging.

INCLUDES

- ※ Power cable length **10 m**
- ※ Float switch (exclusive to single-phase models)

APPLICATION LIMITS

- Depth below water level up to **5 m** (with an appropriately sized power cable)
- Liquid temperature up to **+40 °C**
- Suspended solids transfer:
 - up to **Ø 40 mm** for VX /35-MF
 - up to **Ø 50 mm** for VX /50-MF
- **Minimum immersion for continuous service:**
 - **290 mm** for VX 8-MF and VX 10-MF
 - **330 mm** for VX 15-MF
 - **360 mm** for VX 20-MF

AVAILABLE UPON REQUEST

- ※ Different voltage requirements 60 Hz frequency

PATENTS - TRADE MARKS - MODELS

- Patent No. EP2313658
- Patent No. IT0001428923

CURVES AND PERFORMANCE DATA

50 Hz

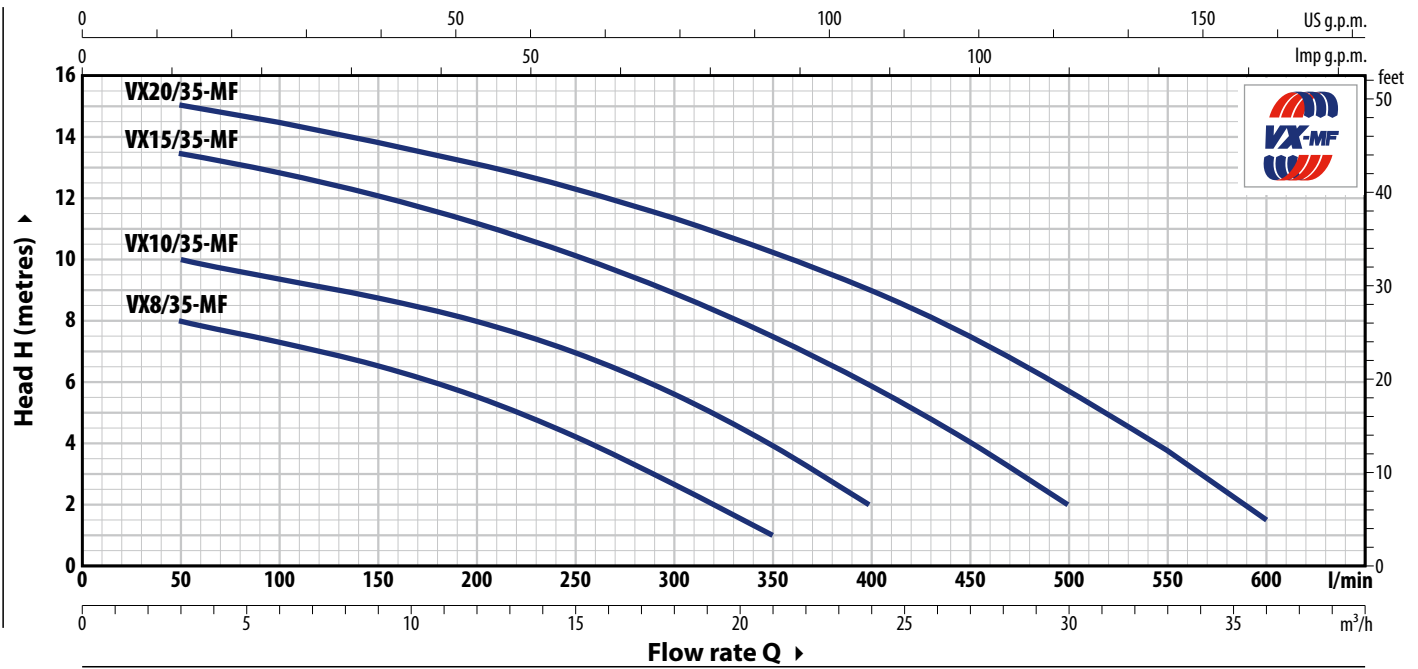

TYPE		POWER (P ₂)		Q	Flow rate												
Single-phase	Three-phase	kW	HP		m ³ /h	0	3	6	12	18	21	24	27	30	33	36	
				l/min	0	50	100	200	300	350	400	450	500	550	600		
VXm 8/35 -MF	VX 8/35 -MF	0.55	0.75	H metres	9	8	7.5	5.5	2.7	1							
VXm 10/35-MF	VX 10/35-MF	0.75	1		11	10	9.5	8	5.7	4	2						
VXm 15/35-MF	VX 15/35-MF	1.1	1.5		14	13.5	12.8	11.2	9	7.7	6	4	2				
VXm 20/35-MF	VX 20/35-MF	1.5	2		15.5	15	14.5	13	11.5	10.3	9	7.5	5.8	3.8	1.5		

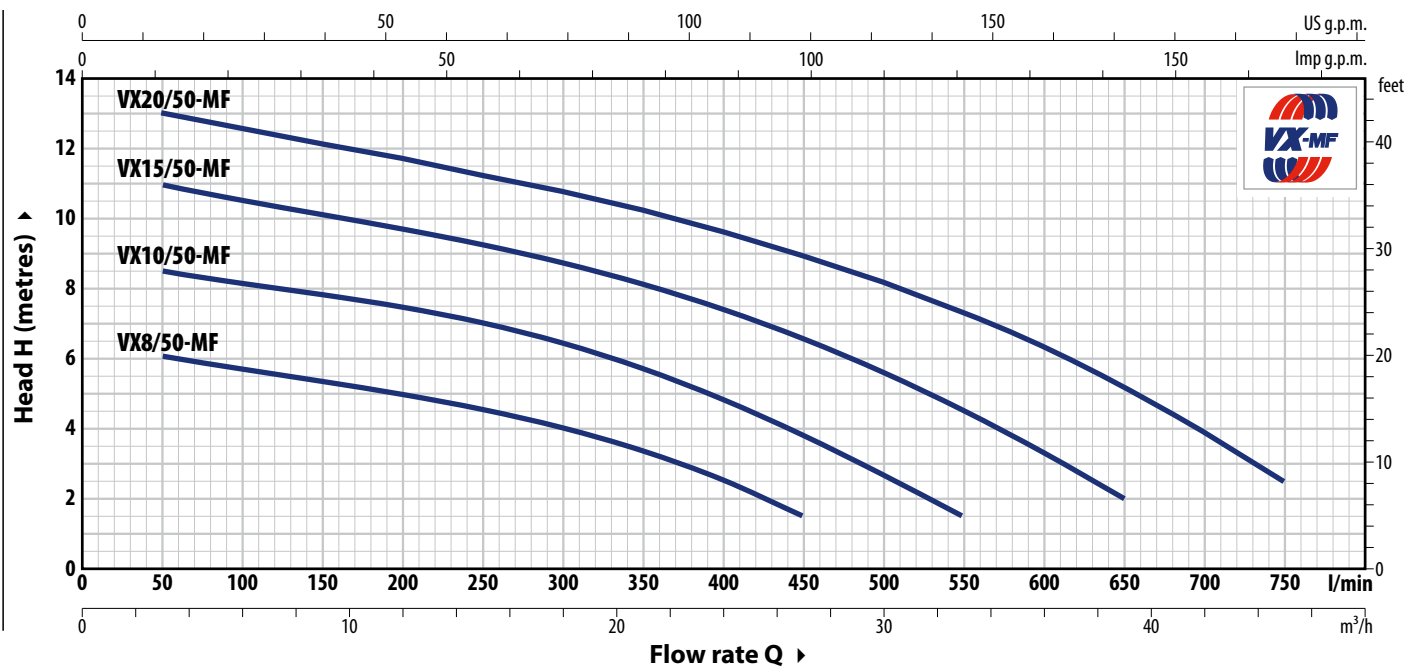

TYPE		POWER (P ₂)		Q	Flow rate													
Single-phase	Three-phase	kW	HP		m ³ /h	0	3	6	12	18	24	27	30	33	36	39	45	
				l/min	0	50	100	200	300	400	450	500	550	600	650	750		
VXm 8/50 -MF	VX 8/50 -MF	0.55	0.75	H metres	6.5	6	5.8	5	4	2.5	1.5							
VXm 10/50-MF	VX 10/50-MF	0.75	1		9	8.5	8.2	7.5	6.5	5	3.8	2.5	1.5					
VXm 15/50-MF	VX 15/50-MF	1.1	1.5		11.5	11	10.5	9.8	8.7	7.5	6.5	5.5	4.5	3.5	2			
VXm 20/50-MF	VX 20/50-MF	1.5	2		13.5	13	12.5	11.5	10.7	9.5	9	8	7.5	6.5	5	2.5		

Q = Flow rate H = Total manometric head

Performance curves comply with EN ISO 9906 Grade 3B tolerance limits.

ABSORPTION

TYPE	VOLTAGE
Single-phase	230 V
VXm 8/35 -MF	4.3 A
VXm 10/35-MF	5.5 A
VXm 15/35-MF	7.0 A
VXm 20/35-MF	9.6 A
VXm 8/50 -MF	4.3 A
VXm 10/50-MF	5.5 A
VXm 15/50-MF	7.0 A
VXm 20/50-MF	9.6 A

TYPE	VOLTAGE
Three-phase	400 V
VX 8/35 -MF	1.6 A
VX 10/35-MF	2.2 A
VX 15/35-MF	2.7 A
VX 20/35-MF	3.7 A
VX 8/50 -MF	1.6 A
VX 10/50-MF	2.2 A
VX 15/50-MF	2.7 A
VX 20/50-MF	3.7 A

DIMENSIONS AND WEIGHT

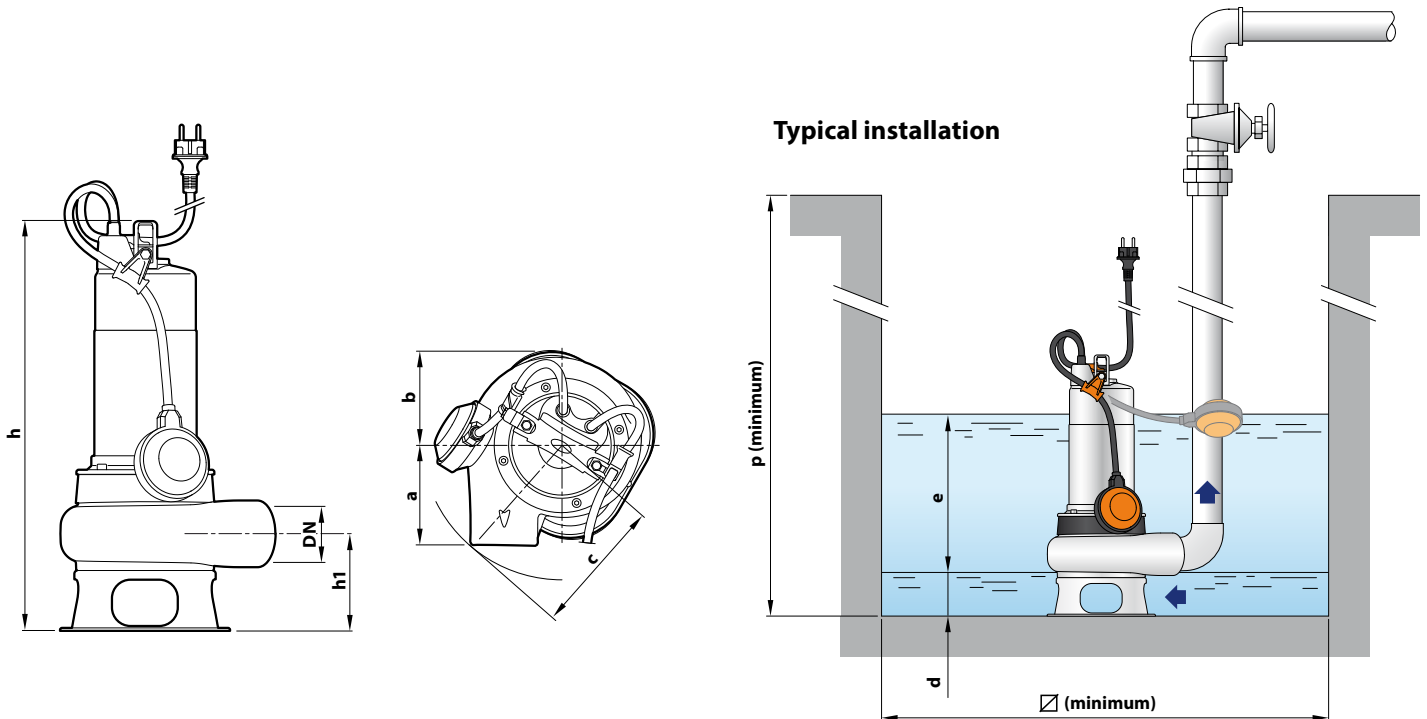

TYPE		PORT DN	Passage of solid bodies	DIMENSIONS mm									kg	
Single-phase	Three-phase			a	b	c	h	h1	d	e	p	∅	1~	3~
VXm 8/35 -MF	VX 8/35 -MF	1½"	Ø 40 mm	107	97	148	424	105	55	adjustable	500	500	12.9	11.8
VXm 10/35-MF	VX 10/35-MF						439						14.4	13.2
VXm 15/35-MF	VX 15/35-MF						472						17.2	15.6
VXm 20/35-MF	VX 20/35-MF						502						19.4	17.2
VXm 8/50 -MF	VX 8/50 -MF	2"	Ø 50 mm	112	97	149	435	107	60	adjustable	500	500	13.2	12.1
VXm 10/50-MF	VX 10/50-MF						450						14.7	13.5
VXm 15/50-MF	VX 15/50-MF						483						17.5	15.9
VXm 20/50-MF	VX 20/50-MF						513						19.7	17.5

PALLET CAPACITY

TYPE		NO. OF PUMPS
Single-phase	Three-phase	
VXm 8/35 -MF	VX 8/35 -MF	45
VXm 10/35-MF	VX 10/35-MF	45
VXm 15/35-MF	VX 15/35-MF	30
VXm 20/35-MF	VX 20/35-MF	30
VXm 8/50 -MF	VX 8/50 -MF	45
VXm 10/50-MF	VX 10/50-MF	45
VXm 15/50-MF	VX 15/50-MF	30
VXm 20/50-MF	VX 20/50-MF	30

MATERIALS AND COMPONENTS

1 Pump body	Micro-cast AISI 316L stainless steel with ISO 228/1 threaded port		
2 Base	Stainless steel AISI 304		
3 Impeller	VORTEX type in AISI 304 stainless steel.		
4 Motor sleeve	Stainless steel AISI 304		
5 Motor cover	AISI 304 stainless steel for VX 8-10 MF Cast iron with cataphoresis treatment for VX 15-20 MF		
6 Motor shaft	Stainless steel AISI 316L		
7 Double mechanical seal in oil chamber			
Seal	Shaft	Location	Materials
MG1-14D SIC	Ø 14 mm	Motor side Pump side	Silicon carbide / Graphite / NBR Silicon carbide/Silicon carbide/NBR
8 Capacitor	(exclusive to single-phase models)		
9 Electric motor			
VXm-MF:	single-phase 230 V - 50 Hz with winding integrated thermal motor protection		
VX-MF:	three-phase 400 V - 50 Hz		
	– Insulation: class F		
	– Protection rating: IP X8		
10 Power cord			
	Power cable encapsulated with epoxy resin both in the grommet area and where the conductors exit the sheath, for absolute insulation against moisture and water.		
	Type 'H07 RN-F (Schuko plug exclusive to single-phase models)		
	※ Standard length 10 metres		
11 Float switch	(exclusive to single-phase models)		
12 Tilting device for the float cable	(exclusive to single-phase models)		
	Patent No. IT0001428923		
13 Power cable strain relief			
	Patent No. EP2313658		

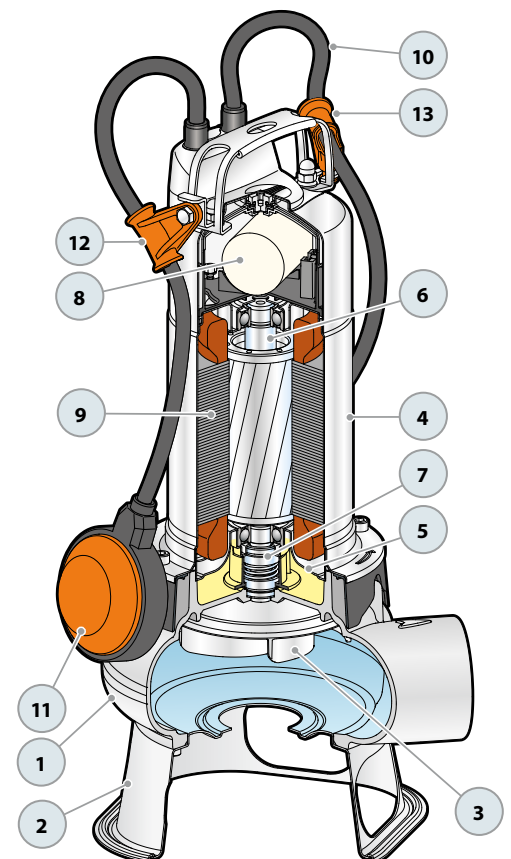

TWO-CHANNEL

※ Experience high-efficiency, quality, and durability



-  Sewage
-  Domestic use
-  Civil use
-  Industrial use

※ Constructed entirely from micro-cast stainless steel, BC-MF submersible pumps offer superior corrosion and abrasion.

PERFORMANCE RANGE

- Flow rate up to **850 l/min** (51 m³/h)
- Head up to **17 m**

INSTALLATION AND USE

BC-MF stainless steel submersible pumps are designed to drain dirty and sewage water in domestic, civil, and industrial settings. Featuring a TWO-CHANNEL impeller, they can efficiently pump liquids containing suspended solids up to 50 mm in diameter with short fibers and handle wastewater, sewage, surface water, and sludge-mixed water in residential properties.

※ The hydraulic configuration of the volute and **TWO-CHANNEL** impeller results from advanced fluid dynamics calculations, delivering superior performance and efficiency for notable energy savings.

※ The **TWO-CHANNEL** impeller provides excellent performance and high energy efficiency, generating increased pressure for pumping solids up to **50 mm** in diameter, making it the best choice for wastewater drainage.

INCLUDES

- ※ Power cable length **10 m**
- ※ Float switch (exclusive to single-phase models)

APPLICATION LIMITS

- Depth below water level up to **5 m** (with an appropriately sized power cable)
- Liquid temperature up to **+40 °C**
- Capable of processing suspended solids up to **Ø 50 mm**
- **Minimum immersion for continuous service:**
 - **290 mm for BC 10/50-MF**
 - **330 mm for BC 15/50-MF**
 - **360 mm for BC 20/50-MF**

AVAILABLE UPON REQUEST

- ※ Different voltage requirements 60 Hz frequency

PATENTS - TRADE MARKS - MODELS

- Patent No. EP2313658
- Patent No. IT0001428923

CURVES AND PERFORMANCE DATA

50 Hz

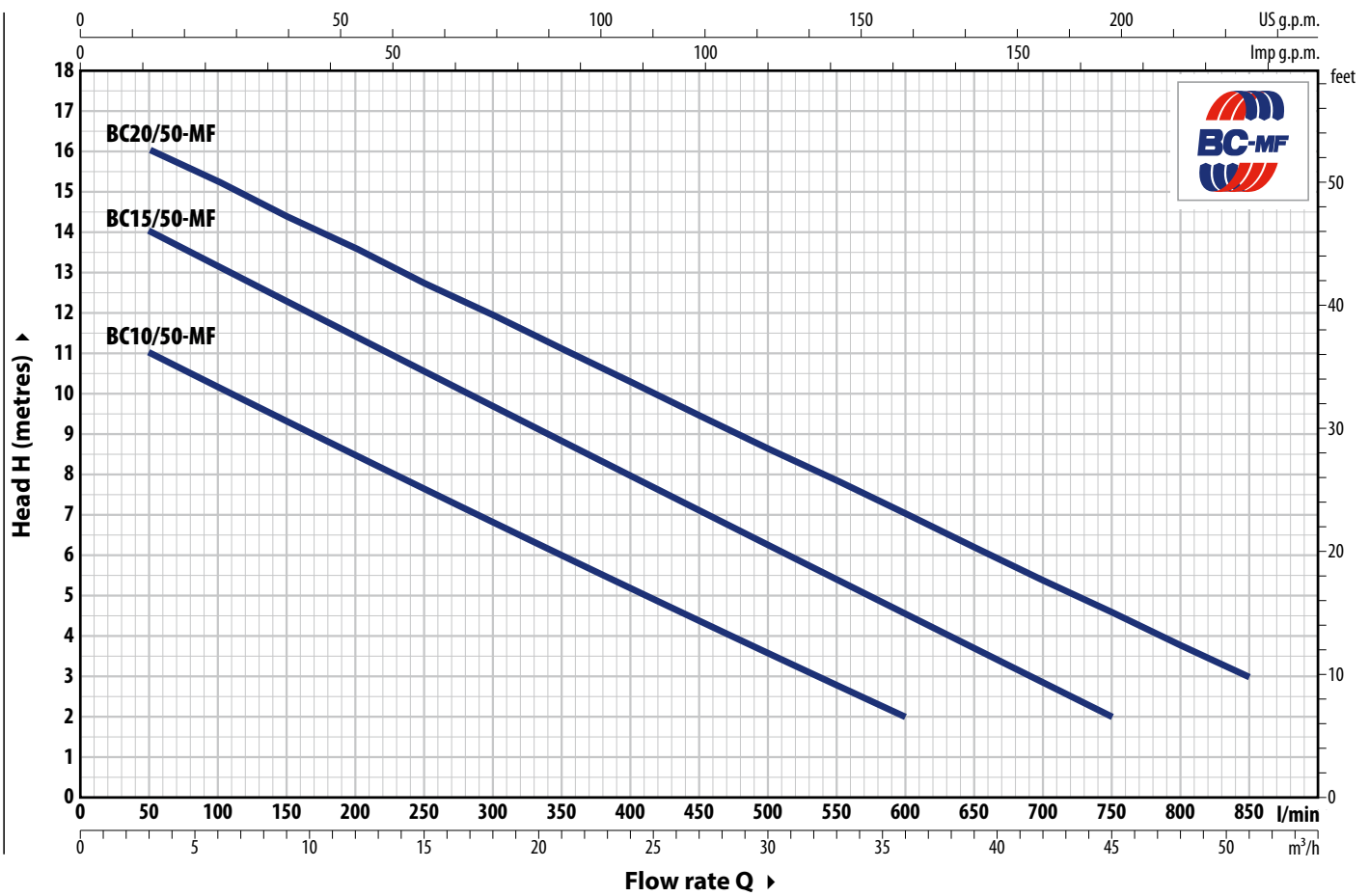

TYPE		POWER (P ₂)		Q	Flow rate														
Single-phase	Three-phase	kW	HP		m ³ /h	0	3	6	12	18	24	30	36	42	45	51			
				l/min	0	50	100	200	300	400	500	600	700	750	850				
BCm 10/50-MF	BC 10/50-MF	0.75	1	H metres	12	11	10	8.5	7	5	3.6	2							
BCm 15/50-MF	BC 15/50-MF	1.1	1.5		15	14	13	11.5	9.7	8	6.3	4.6	3	2					
BCm 20/50-MF	BC 20/50-MF	1.5	2		17	16	15.3	13.5	12	10.3	8.6	7.0	5.3	4.5	3				

Q = Flow rate H = Total manometric head

Performance curves comply with EN ISO 9906 Grade 3B tolerance limits.

ABSORPTION

TYPE	VOLTAGE
Single-phase	230 V
BCm 10/50-MF	5.5 A
BCm 15/50-MF	8.0 A
BCm 20/50-MF	10.0 A

TYPE	VOLTAGE
Three-phase	400 V
BC 10/50-MF	2.2 A
BC 15/50-MF	3.1 A
BC 20/50-MF	3.9 A

DIMENSIONS AND WEIGHT

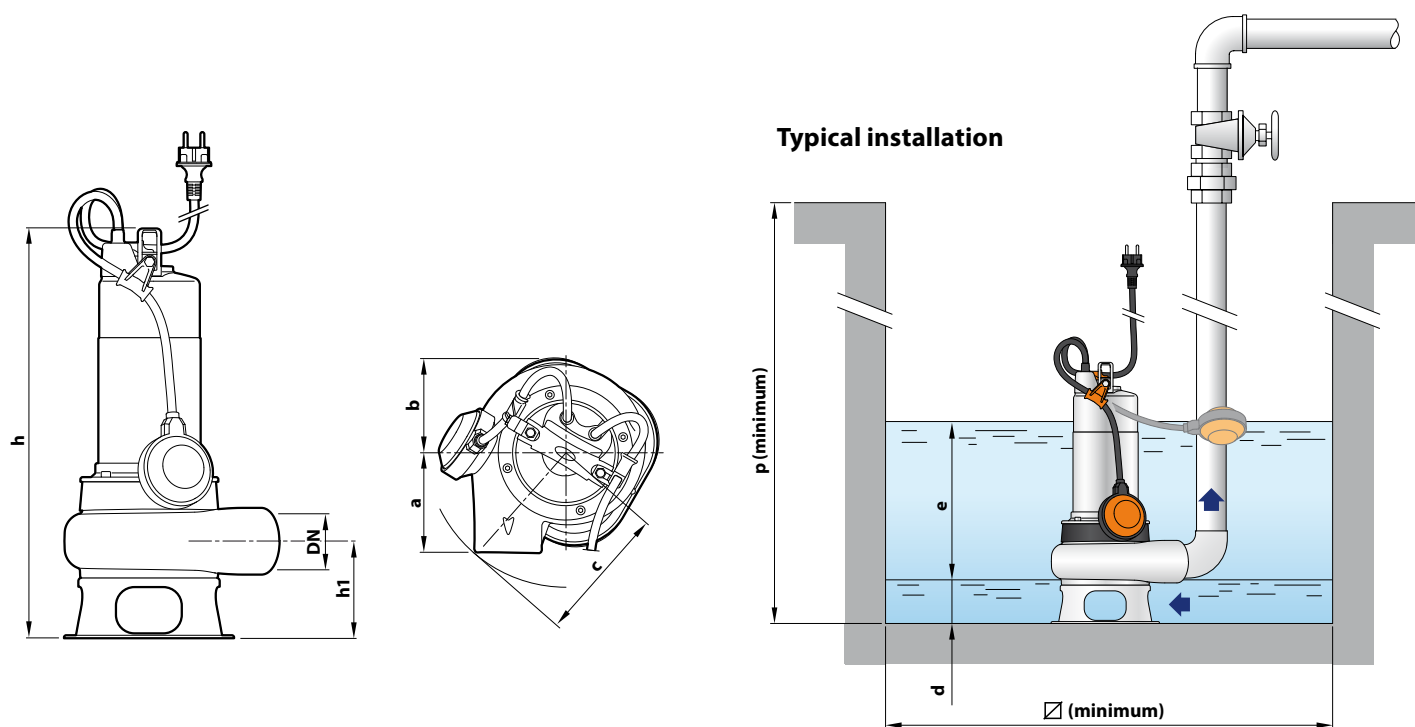

TYPE		PORT DN	Passage of solid bodies	DIMENSIONS mm										kg	
Single-phase	Three-phase			a	b	c	h	h1	d	e	p	□	1~	3~	
BCm 10/50-MF	BC 10/50-MF	2"	Ø 50 mm	102	95	145	450	107	60	adjustable	500	500	15.2	14.0	
BCm 15/50-MF	BC 15/50-MF						483						17.8	16.2	
BCm 20/50-MF	BC 20/50-MF						513						20.0	17.8	

PALLET CAPACITY

TYPE		NO. OF PUMPS
Single-phase	Three-phase	
BCm 10/50-MF	BC 10/50-MF	45
BCm 15/50-MF	BC 15/50-MF	30
BCm 20/50-MF	BC 20/50-MF	30

MATERIALS AND COMPONENTS

1 Pump body	Micro-cast AISI 316L stainless steel with ISO 228/1 threaded port												
2 Base	Stainless steel AISI 304												
3 Impeller	TWO-CHANNEL type in micro-cast AISI 304 stainless steel.												
4 Motor sleeve	Stainless steel AISI 304												
5 Motor cover	AISI 304 stainless steel for BC 10/50-MF Cast iron with cataphoresis treatment for BC 15/50-MF, BC 20/50-MF												
6 Motor shaft	Stainless steel AISI 316L												
7 Double mechanical seal in oil chamber	<table border="1"> <thead> <tr> <th>Seal</th> <th>Shaft</th> <th>Location</th> <th>Materials</th> </tr> </thead> <tbody> <tr> <td rowspan="2">MG1-14D SIC</td> <td rowspan="2">Ø 14 mm</td> <td>Motor side</td> <td>Silicon carbide / Graphite / NBR</td> </tr> <tr> <td>Pump side</td> <td>Silicon carbide/Silicon carbide/NBR</td> </tr> </tbody> </table>			Seal	Shaft	Location	Materials	MG1-14D SIC	Ø 14 mm	Motor side	Silicon carbide / Graphite / NBR	Pump side	Silicon carbide/Silicon carbide/NBR
Seal	Shaft	Location	Materials										
MG1-14D SIC	Ø 14 mm	Motor side	Silicon carbide / Graphite / NBR										
		Pump side	Silicon carbide/Silicon carbide/NBR										
8 Capacitor	(exclusive to single-phase models)												
9 Electric motor	<p>BCm-MF: single-phase 230 V - 50 Hz with winding integrated thermal motor protection</p> <p>BC-MF: three-phase 400 V - 50 Hz</p> <ul style="list-style-type: none"> - Insulation: class F - Protection rating: IP X8 												
10 Power cord	<p>Power cable encapsulated with epoxy resin both in the grommet area and where the conductors exit the sheath, for absolute insulation against moisture and water.</p> <p>Type 'H07 RN-F' (Schuko plug exclusive to single-phase models)</p> <p>※ Standard length 10 metres</p>												
11 Float switch	(exclusive to single-phase models)												
12 Tilting device for the float cable	(exclusive to single-phase models) Patent No. IT0001428923												
13 Power cable strain relief	Patent No. EP2313658												

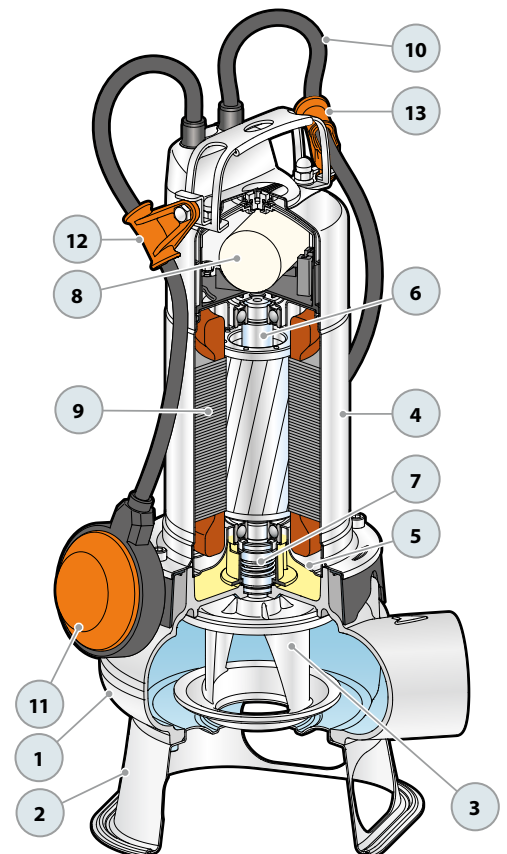

SEWAGE LIFTING SYSTEM KIT VX-MF - BC-MF

VERSION WITH HORIZONTAL DELIVERY AND 3/4" GUIDE PIPES

For VX /35-MF	CODE ASSPVX35ST	DN 2"
Per VX /50-MF , BC /50-MF	CODE ASSPVX50ST	DN 2"

※ Kit consisting of:



Coupling foot



Solids rail with ring nut and seal



Support for guide tubes



VERSION WITH VERTICAL DELIVERY AND 3/4" GUIDE PIPES

For VX /35-MF	CODE ASSPVX35STV	DN 2 1/2"
For VX /50-MF , BC /50-MF	CODE ASSPVX50STV	DN 2 1/2"

※ Kit consisting of:



Coupling foot complete with counterflange



Solids rail with ring nut and seal



Support for guide tubes



● ACCESSORIES AVAILABLE FOR ORDER

RUNNING GUIDE

※ For VX /35-MF	CODE ASSFL005
※ For VX /50-MF , BC /50-MF	CODE ASSFL006

Complete with ring nut and gasket



GUIDE TUBE SUPPORT

※ For Ø 3/4 " guide tubes	CODE 859SV340INTFA
---------------------------	--------------------

To ensure stability, insert a support every 2 metres along the guide tube



GUIDE TUBE (AISI 304 stainless steel)

※ 2 metres Ø 3/4" guide tube	CODE 54SARTG0052F
※ 3 metres Ø 3/4" guide tube	CODE 54SARTG0053F
※ 6 metres Ø 3/4" guide tube	CODE 54SARTG0056F



DIMENSIONS (Version with horizontal outlet)

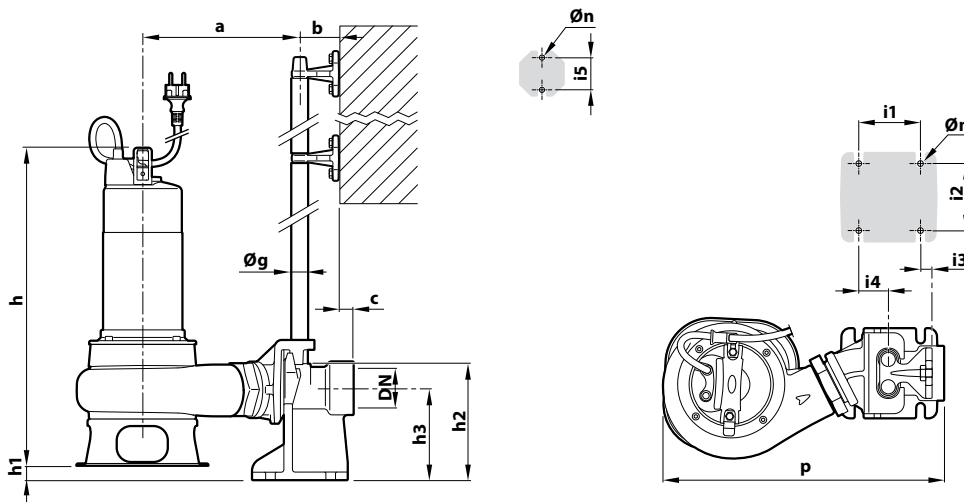

TYPE		Passage of solid bodies mm	PORT DN	DIMENSIONS mm															
Single-phase	Three-phase			a	b	c	p	h	h1	h2	h3	i1	i2	i3	i4	i5	Øg	Øm	Øn
VXm 8/35 -MF	VX 8/35 -MF	40	2"	222			395	424	25										
VXm 10/35 -MF	VX 10/35 -MF							439											
VXm 15/35 -MF	VX 15/35 -MF							472											
VXm 20/35 -MF	VX 20/35 -MF							502											
VXm 8/50 -MF	VX 8/50 -MF	50	2"	226	61	17	398	435	23	165	130	85	94	16	40	50	¾"	12	11
VXm 10/50 -MF	VX 10/50 -MF							450											
VXm 15/50 -MF	VX 15/50 -MF							483											
VXm 20/50 -MF	VX 20/50 -MF							513											
BCm 10/50 -MF	BC 10/50 -MF	50	2"					450											
BCm 15/50 -MF	BC 15/50 -MF							483											
BCm 20/50 -MF	BC 20/50 -MF							513											

DIMENSIONS (Version with vertical delivery)

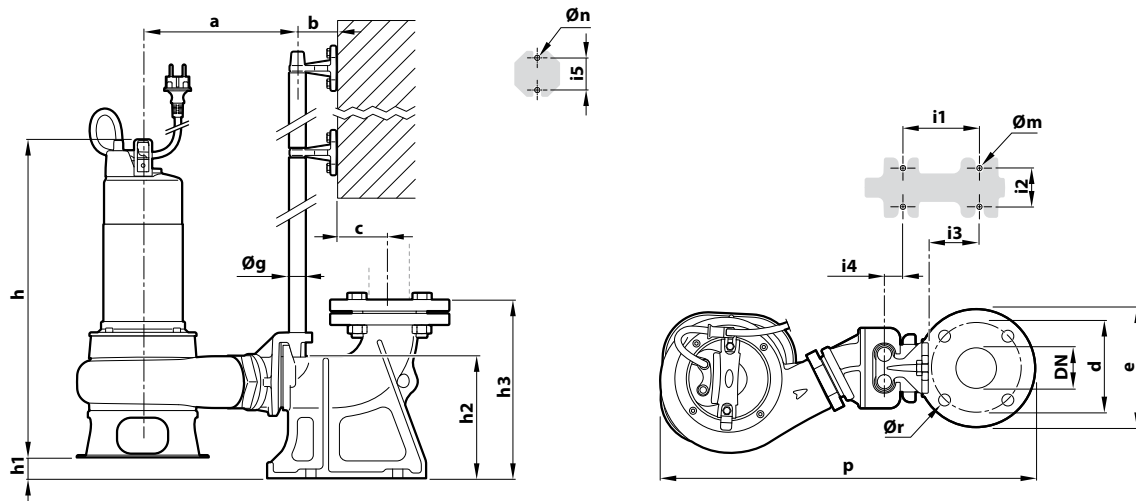

TYPE		Passage of solid bodies mm	PORT DN	DIMENSIONS mm																		
Single-phase	Three-phase			a	b	c	d	e	p	h	h1	h2	h3	i1	i2	i3	i4	i5	Øg	Øm	Øn	Ør
VXm 8/35 -MF	VX 8/35 -MF	40	2½"	215					503	23												
VXm 10/35 -MF	VX 10/35 -MF																				439	
VXm 15/35 -MF	VX 15/35 -MF																				472	
VXm 20/35 -MF	VX 20/35 -MF																				502	
VXm 8/50 -MF	VX 8/50 -MF	50	2½"	217	61	52	125	165	507	21	164	215	120	72	62	3	50	¾"	14	11	18	
VXm 10/50 -MF	VX 10/50 -MF																					450
VXm 15/50 -MF	VX 15/50 -MF																					483
VXm 20/50 -MF	VX 20/50 -MF																					513
BCm 10/50 -MF	BC 10/50 -MF	50	2½"																			
BCm 15/50 -MF	BC 15/50 -MF																				450	
BCm 20/50 -MF	BC 20/50 -MF																				483	

D Submersible pumps for drainage

-  Clear waters
-  Domestic use
-  Civil use



PERFORMANCE RANGE

- Flow rate up to **300 l/min** (18 m³/h)
- Head up to **26 m**

INSTALLATION AND USE

Designed to **drain clear** or slightly dirty water, **D-Series** pumps are ideal for **domestic and civil applications**, including basement and garage flood mitigation, swimming pool and tank drainage, and non-sewage wastewater disposal. Known for their reliability, these pumps excel in automated fixed installations.

INCLUDES

- ※ Power cable length:
 - **5 m** for D8, D10, D20
 - **10 m** for D30
- ※ Float switch (exclusive to single-phase models)

APPLICATION LIMITS

- Depth below water level up to **5 m** (with an appropriately sized power cable)
- Liquid temperature up to **+40 °C**
- Capable of processing suspended solids up to **Ø 10 mm**
- Bottom drainage level up to **17 mm**
- **Minimum immersion for continuous service:**
 - **210 mm for D 8-10-20**
 - **250 mm for D 30**

AVAILABLE UPON REQUEST

- ※ Pumps with **10 m** power cable.
- ※ Different voltage requirements 60 Hz frequency

PATENTS - TRADE MARKS - MODELS

- Patent No. EP2313658
- Patent No. IT0001428923

CURVES AND PERFORMANCE DATA

50 Hz

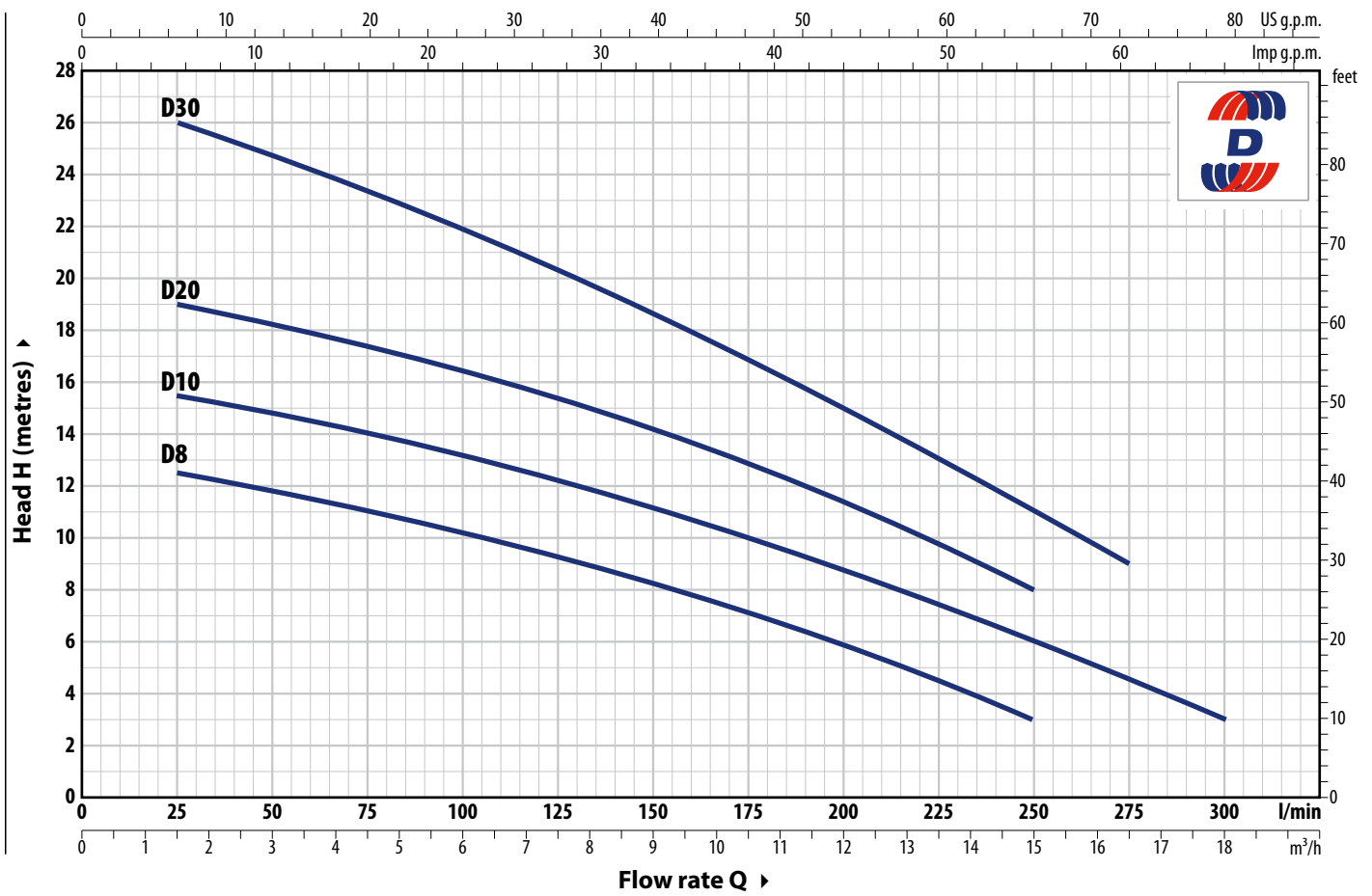

TYPE		POWER (P ₂)		Q	Flow rate																	
Single-ph.	Three-ph.	kW	HP		m ³ /h	0	1.5	3.0	4.5	6.0	7.5	9.0	10.5	12.0	13.2	15.0	16.5	18.0				
				l/min	0	25	50	75	100	125	150	175	200	220	250	275	300					
Dm 8	D 8	0.55	0.75	H metres	13	12.5	12	11	10	9	8	7	6	4.7	3							
Dm 10	D 10	0.75	1		16	15.5	15	14	13.2	12.2	11.2	10	8.8	7.8	6	4.5	3					
Dm 20	D 20	0.75	1		20	19	18.5	17.5	16.5	15.5	14.3	13	11.5	10	8							
Dm 30	D 30	1.1	1.5		26	26	25	23.5	22	20.5	18.7	17	15	13.5	11	9						

Q = Flow rate H = Total manometric head

Performance curves comply with EN ISO 9906 Grade 3B tolerance limits.

ABSORPTION

TYPE	VOLTAGE
Single-ph.	230 V
Dm 8	3.4 A
Dm 10	5.0 A
Dm 20	5.5 A
Dm 30	7.3 A

TYPE	VOLTAGE
Three-ph.	400 V
D 8	1.4 A
D 10	2.0 A
D 20	2.2 A
D 30	3.0 A

DIMENSIONS AND WEIGHT

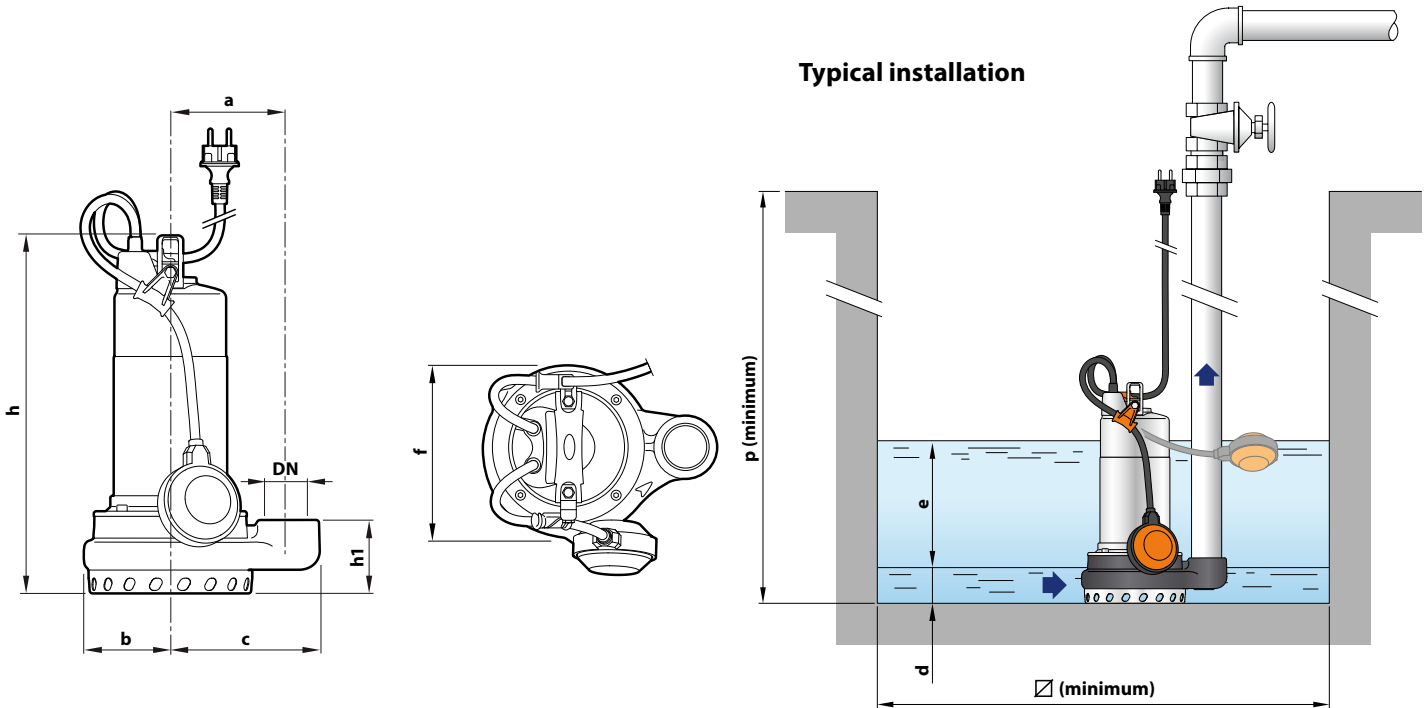

TYPE		PORT DN	DIMENSIONS mm										kg	
Single-ph.	Three-ph.		a	b	c	f	h	h1	d	e	p	∅	1~	3~
Dm 8	D 8	1½"	115	85	147	177	338	73	17	adjustable	500	500	12.8	11.7
Dm 10	D 10						353						14.0	12.9
Dm 20	D 20						390						14.0	12.9
Dm 30	D 30			93			195	84					17.4	16.0

PALLET CAPACITY

TYPE		NO. OF PUMPS
Single-ph.	Three-ph.	
Dm 8	D 8	60
Dm 10	D 10	60
Dm 20	D 20	60
Dm 30	D 30	60

MATERIALS AND COMPONENTS

1 Pump body	Cast iron with cathaphoresis treatment, provided with ISO 228/1 threaded port
2 Suction filter	Stainless steel AISI 304
3 Suction cover	Stainless steel AISI 304
4 Impeller	Open type in technopolymer
5 Motor sleeve	Stainless steel AISI 304
6 Motor cover	AISI 304 stainless steel for D 8-10-20 Cast iron with cathaphoresis treatment for D 30
7 Motor shaft	Stainless steel AISI 431

8 Double shaft seal with interposed oil chamber

Water pump	Seal	Shaft	Location	Materials
D8, D10, D20	MG1-14D SIC	Ø 14 mm	Motor side	SiC / Graphite / NBR
			Pump side	SiC / SiC / NBR
D30	ST1-14 SIC Shaft seal	Ø 14 mm Ø 16 x Ø 24 x H 5 mm		Ceramic / SiC / NBR

9 Capacitor

(exclusive to single-phase models)

10 Electric motor

Dm: single-phase 230 V - 50 Hz with winding integrated thermal motor protection

D: three-phase 400 V - 50 Hz

– Insulation: class F

– Protection rating: IP X8

11 Power cord

Type 'H07 RN-F

(Schuko plug exclusive to single-phase models)

※ Standard length 5 metres (10 metres for D30)

12 Float switch (exclusive to single-phase models)

13 Tilting device for the float cable

(exclusive to single-phase models)

Patent No. IT0001428923

14 Power cable strain relief

Patent No. EP2313658

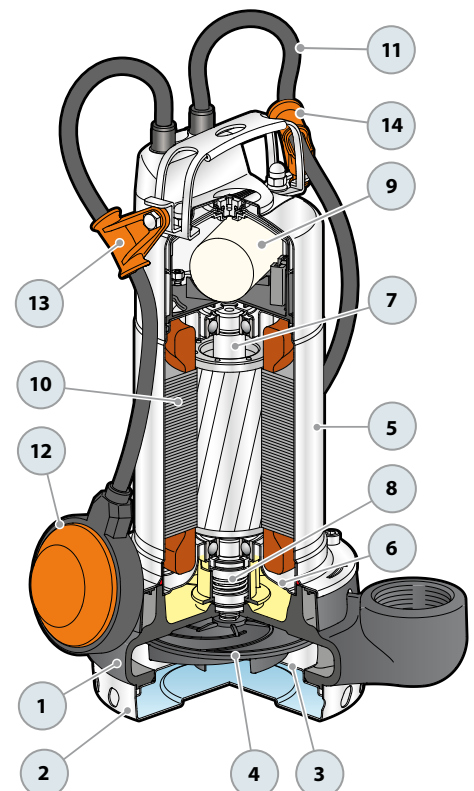



Dirty water



Domestic use



Civil use



※ Innovative pumps:
high performance,
quality, and durability

PERFORMANCE RANGE

- Flow rate up to **400 l/min** (24 m³/h)
- Head up to **13 m**

INSTALLATION AND USE

ZXm 2 pumps are designed for sewage drainage in **domestic and civil settings**.

- ※ Featuring a **VORTEX** impeller, these pumps efficiently handle solids up to **40 mm** in diameter, with a unique design that prevents clogging.

INCLUDES

- ※ **5 m** power cable
- ※ Float switch
- ※ Hose connector **Ø 50 mm**

APPLICATION LIMITS

- Maximum operating depth below water level up to **5 m** (with an appropriately sized power cable)
- Liquid temperature up to **+40 °C**
- Suspended solids transfer:
 - up to **Ø 30 mm** for ZXm 2/30
 - up to **Ø 40 mm** for ZXm 2/40
- **Minimum immersion for continuous service:**
 - **265 mm** for ZXm 2/30
 - **275 mm** for ZXm 2/40

CURVES AND PERFORMANCE DATA

50 Hz

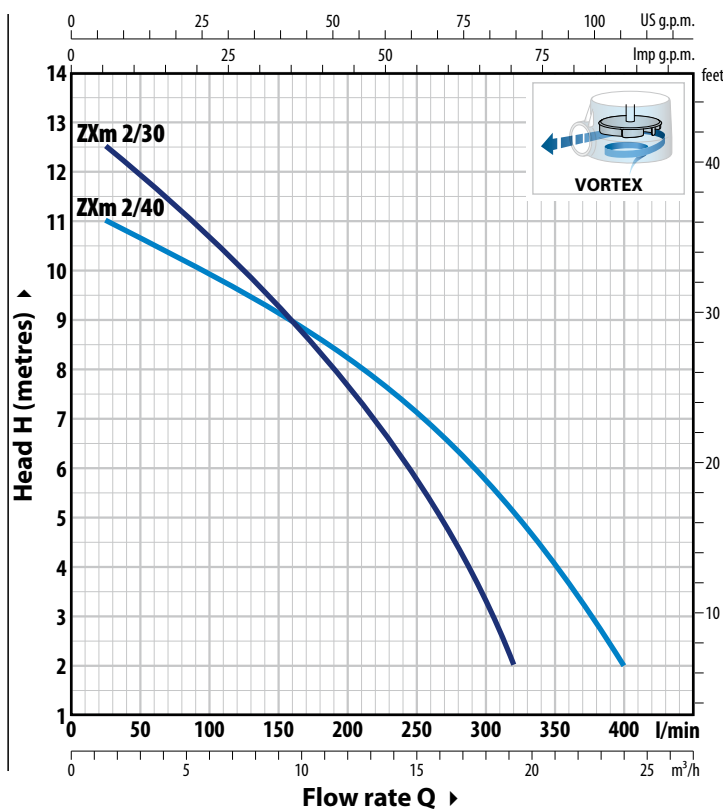

AVAILABLE UPON REQUEST

- ※ Pumps with **10 m** power cable
- ※ Different voltage requirements 60 Hz frequency

PATENTS - TRADE MARKS - MODELS

- Patent No. EP2313658
- Patent No. IT0001428923

ABSORPTION

TYPE	VOLTAGE
Single-phase	230 V
ZXm 2/30	4.0 A
ZXm 2/40	4.0 A

TYPE	POWER (P ₂)		Q	Flow rate												
	kW	HP		m ³ /h	0	1.5	3	6	9	12	15	18	19.2	21	24	
Single-phase			l/min	0	25	50	100	150	200	250	300	320	350	400		
ZXm 2/30	0.55	0.75	H metres	13	12.5	11.8	10.6	9.3	7.6	5.8	3.3	2				
ZXm 2/40	0.55	0.75		11.5	11	10.6	9.8	9.2	8.2	7.2	5.7	5.2	4	2		

Q = Flow rate H = Total manometric head

Performance curves comply with EN ISO 9906 Grade 3B tolerance limits.

MATERIALS AND COMPONENTS

1 Pump body	Fibreglass-filled technopolymer with ISO 228/1 threaded delivery port (5-year warranty)		
2 Base	Glass-fibre reinforced technopolymer		
3 Impeller	VORTEX type made of glass-fibre reinforced technopolymer		
4 Motor sleeve	Stainless steel AISI 304		
5 Motor cover	Stainless steel AISI 304		
6 Motor shaft	Stainless steel AISI 431		
7 Double mechanical seal with interposed oil chamber			
Seal	Shaft	Location	Materials
MG1-14D SIC	\varnothing 14 mm	Motor side	SiC / Graphite / NBR
		Pump side	SiC / SiC / NBR
8 Capacitor			
9 Electric motor	Single-phase 230 V - 50 Hz with winding integrated thermal motor protection - Insulation: class F - Protection rating: IP X8		
10 Power cord	Type 'H07 RN-F' with Schuko plug ※ Standard length 5 metres		
11 Float switch			
12 Tilting device for the float cable	Patent No. IT0001428923		
13 Power cable strain relief	Patent No. EP2313658		
14 Hose connector \varnothing 50 mm (included in delivery)			

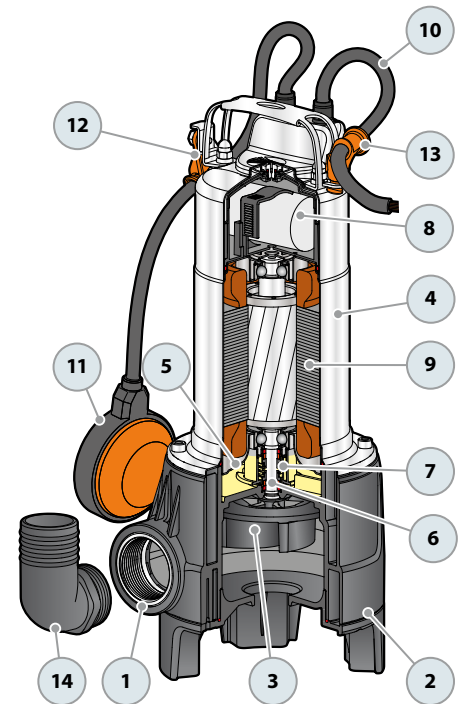

DIMENSIONS AND WEIGHT

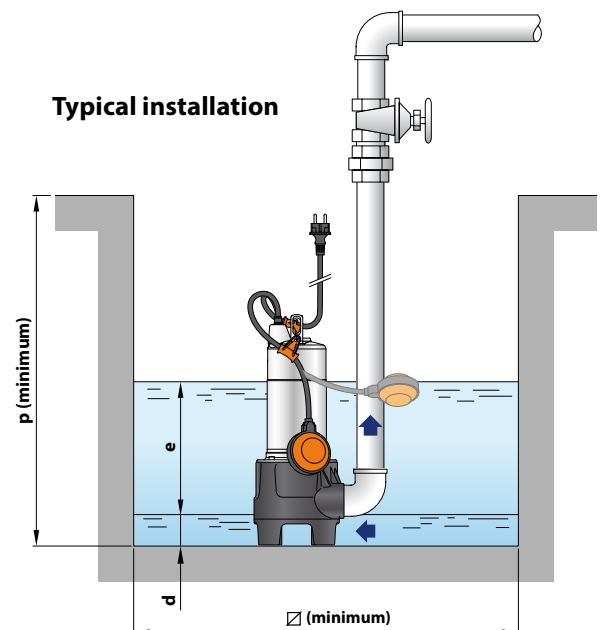
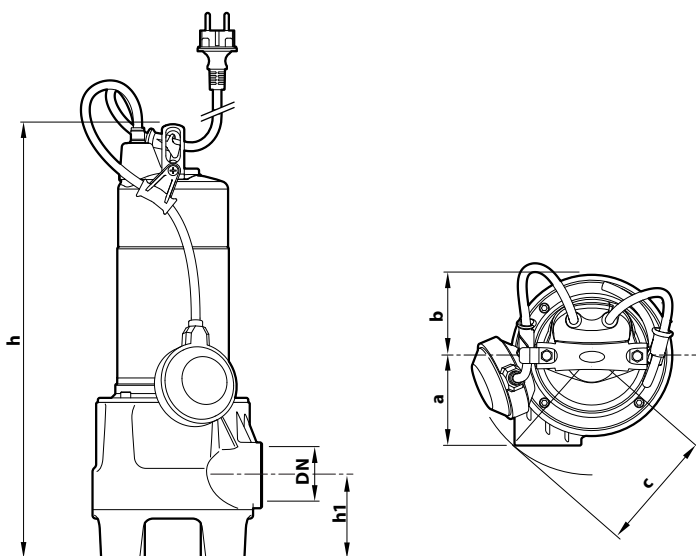

TYPE	PORT DN	Passage of solid bodies	DIMENSIONS mm									kg 1~	PALLET CAPACITY
			a	b	c	h	h1	d	e	p	\varnothing		
Single-phase	1½"	\varnothing 30 mm	90	81	118	412	73	50	adjustable	500	500	10.8	54
ZXm 2/30		\varnothing 40 mm				422	83						
ZXm 2/40													54



Dirty water



Domestic use



Civil use

※ Innovative pumps with high performance, quality and durability



PERFORMANCE RANGE

- Flow rate up to **400 l/min** (24 m³/h)
- Head up to **13 m**

INSTALLATION AND USE

ZXm 2-GM pumps are recommended for drainage of **sewage** in the **domestic and civil** sectors, for the evacuation of dirty water even in **very small spaces (sumps of only 220 mm side)**.

※ The **VORTEX** impeller allows the pumping of solids with a diameter of up to **40 mm** and, thanks to its special geometry, guarantees safe operation against clogging.

INCLUDES

- ※ Adjustable vertical magnetic float switch
- ※ Hose connector **Ø 50 mm**
- ※ **5 m** power cable

APPLICATION LIMITS

- Depth below water level up to **5 m** (with an appropriately sized power cable)
- Liquid temperature up to **+40 °C**
- Suspended solids transfer:
 - up to **Ø 30 mm** for ZXm 2/30-GM
 - up to **Ø 40 mm** for ZXm 2/40-GM
- **Minimum immersion for continuous service:**
 - **265 mm** for ZXm 2/30-GM
 - **275 mm** for ZXm 2/40-GM

AVAILABLE UPON REQUEST

- ※ Pumps with **10 m** power cable
- ※ Different voltage requirements 60 Hz frequency

ABSORPTION

TYPE	VOLTAGE
Single-phase	230 V
ZXm 2/30-GM	4.0 A
ZXm 2/40-GM	4.0 A

CURVES AND PERFORMANCE DATA

50 Hz

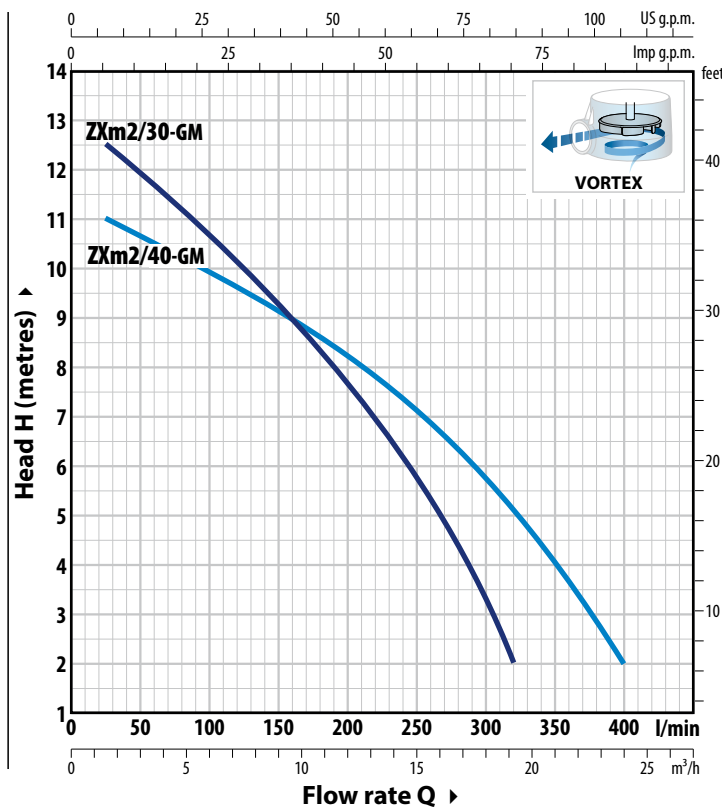

TYPE	POWER (P ₂)		Q	Flow rate												
	kW	HP		m ³ /h	0	1.5	3	6	9	12	15	18	19.2	21	24	
Single-phase			l/min	0	25	50	100	150	200	250	300	320	350	400		
ZXm 2/30-GM	0.55	0.75	H metres	13	12.5	11.8	10.6	9.3	7.6	5.8	3.3	2				
ZXm 2/40-GM	0.55	0.75		11.5	11	10.6	9.8	9.2	8.2	7.2	5.7	5.2	4	2		

Q = Flow rate H = Total manometric head

Performance curves comply with EN ISO 9906 Grade 3B tolerance limits.

MATERIALS AND COMPONENTS

1 Pump body	Fibreglass-filled technopolymer with ISO 228/1 threaded delivery port (5-year warranty)		
2 Base	Glass-fibre reinforced technopolymer		
3 Impeller	VORTEX type made of glass-fibre reinforced technopolymer		
4 Motor sleeve	Stainless steel AISI 304		
5 Motor cover	Stainless steel AISI 304		
6 Motor shaft	Stainless steel AISI 431		
7 Double mechanical seal with interposed oil chamber	Seal	Shaft	Location
			Materials
	MG1-14D SIC	\varnothing 14 mm	Motor side Pump side
			SiC / Graphite / NBR SiC / SiC / NBR
8 Capacitor			
9 Electric motor	Single-phase 230 V - 50 Hz with winding integrated thermal motor protection - Insulation: class F - Protection rating: IP X8		
10 Power cord	Type 'H07 RN-F' with Schuko plug ※ Standard length 5 metres		
11 Float level switch	Float magnetic vertical solids adjustable		
12 Hose connector	\varnothing 50 mm (included in delivery)		

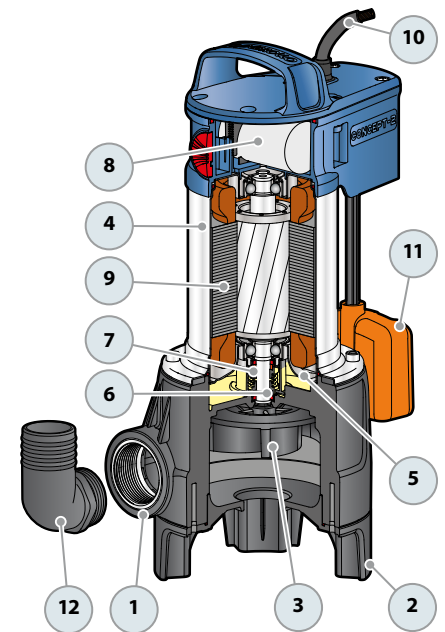

DIMENSIONS AND WEIGHT

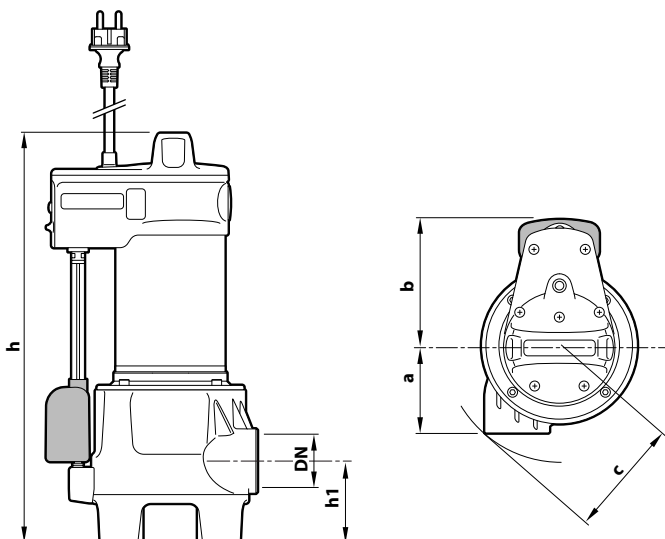

Typical installation

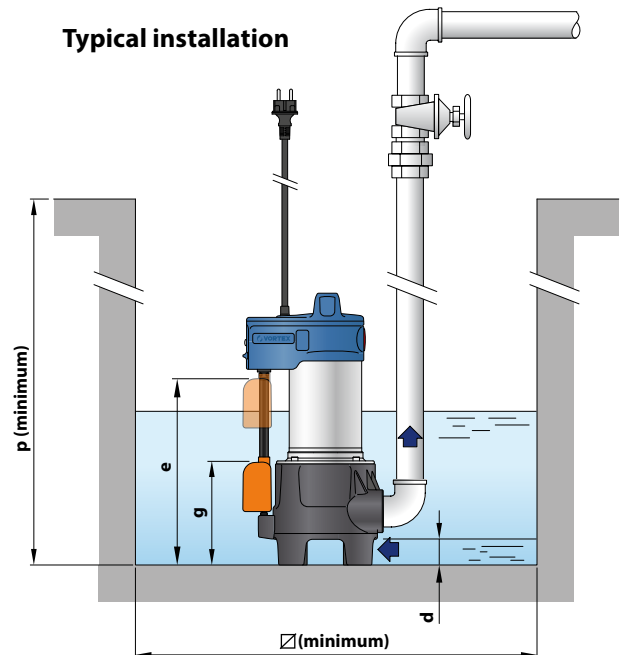

TYPE	PORT DN	Passage of solid bodies	DIMENSIONS mm										kg	PALLET CAPACITY	
			a	b	c	h	h1	d	g (adjustable)	e	p	Ø			
Single-phase															
ZXm 2/30-GM	1½"	Ø 30 mm	90	127	118	394	73	50	130	260	450	300	10.6	54	
ZXm 2/40-GM		Ø 40 mm				404	83		140	270			10.6		



Dirty water



Domestic use



※ **FAMILY is an innovative and reliable stainless steel product**

PERFORMANCE RANGE

- Flow rate up to **250 l/min** (15 m³/h)
- Head up to **10 m**

INSTALLATION AND USE

The **FAMILY** pump is designed for **dirty water** and sewage drainage in **domestic settings**, capable of handling suspended solids up to **30 mm in diameter**. It's easy to operate and reliable in automated fixed installations.

INCLUDES

- ※ **5 m** power cable
- ※ Float switch
- ※ Rubber element holder

APPLICATION LIMITS

- Depth below water level up to **5 m** (with an appropriately sized power cable)
- Liquid temperature up to **+40 °C**
- Capable of processing suspended solids up to **Ø 30 mm**
- **Minimum immersion for continuous service: 160 mm**

AVAILABLE UPON REQUEST

- ※ Technopolymer impeller (economic)
- ※ Pumps with **10 m** power cable
- ※ Different voltage requirements 60 Hz frequency

PATENTS - TRADE MARKS - MODELS

- Patent No. IT0001428923

CURVES AND PERFORMANCE DATA

50 Hz

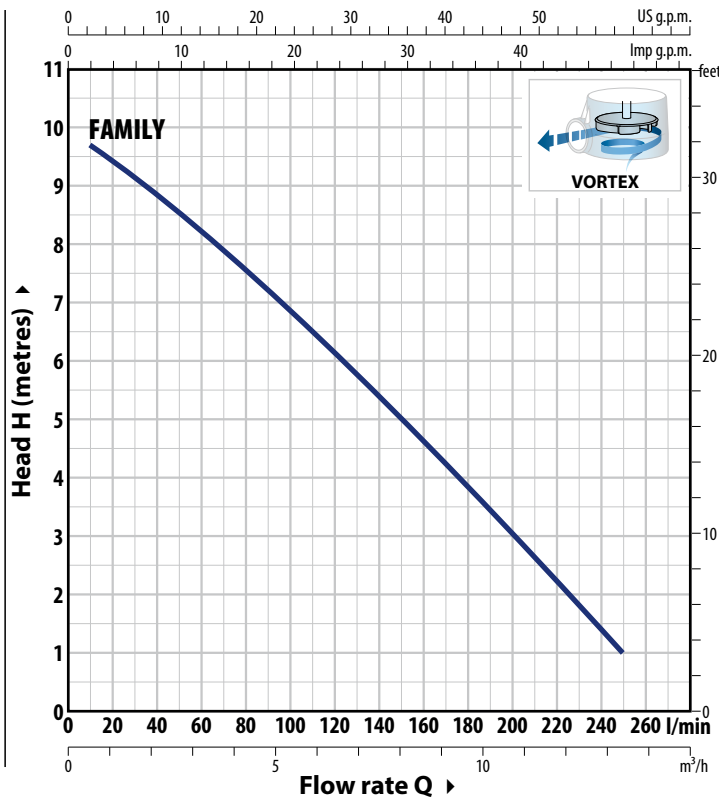

ABSORPTION

TYPE	VOLTAGE
Single-phase	230 V
FAMILY	3.0 A

TYPE	POWER (P ₂)		Q	Flow rate														
	kW	HP		m ³ /h	0	0.6	1.2	2.4	3.6	4.8	6	7.2	8.4	9.6	10.8	12	13.2	15
Single-phase			l/min	0	10	20	40	60	80	100	120	140	160	180	200	220	250	
FAMILY	0.50	0.70	H metres	10	9.7	9.4	9	8.2	7.6	7	6	5.4	4.6	3.7	3	2.2	1	

Q = Flow rate H = Total manometric head

Performance curves comply with EN ISO 9906 Grade 3B tolerance limits.

MATERIALS AND COMPONENTS

1 Pump body	AISI 304 stainless steel with ISO 228/1 threaded port		
2 Base	Stainless steel AISI 304		
3 Impeller	VORTEX type in AISI 304 stainless steel		
4 Motor sleeve	Stainless steel AISI 304		
5 Motor shaft	Stainless steel AISI 431		
6 Double shaft seal	Seal	Shaft	Materials
	STA-12R	Ø 12 mm	Ceramic / Graphite / NBR
	Shaft seal	Ø 12 x Ø 19 x H 5 mm	
7 Capacitor			
8 Electric motor	Single-phase 230 V - 50 Hz with winding integrated thermal motor protection - Insulation: class F - Protection rating: IP X8		
9 Power cord	Type 'H07 RN-F' with Schuko plug ※ Standard length 5 metres		
10 Float switch			
11 Tilting device for the float cable	Patent No. IT0001428923		
12 Hose holder (included in delivery)	Ø 50 mm		

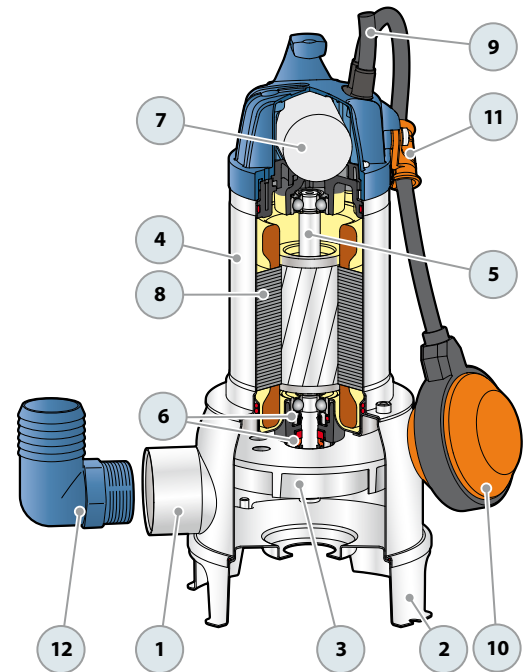

DIMENSIONS AND WEIGHT

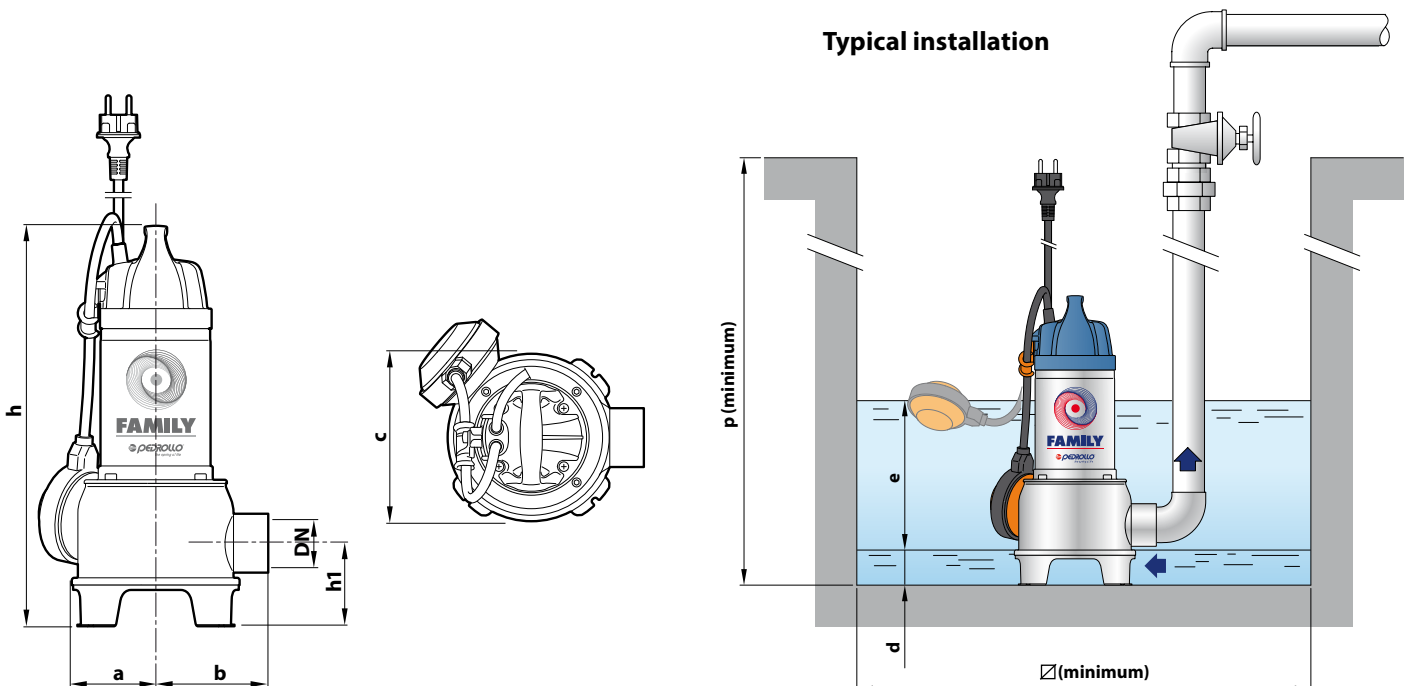

TYPE	PORT DN	Passage of solid bodies	DIMENSIONS mm									kg 1~	PALLET CAPACITY	
			a	b	c	h	h1	d	e	p	Ø			
Single-phase														
FAMILY	1½"	Ø 30 mm	70	93	140	333	68	40	adjustable	450	450	7.0	96	



Dirty water



Domestic use



PERFORMANCE RANGE

- Flow rate up to **400 l/min** (24 m³/h)
- Head up to **11 m**

INSTALLATION AND USE

ZXm 1 pump is designed for **dirty water** and sewage drainage in **domestic settings**, capable of handling suspended solids up to **40 mm in diameter**. It's easy to operate and reliable in automated fixed installations.

INCLUDES

- ✳ **5 m** power cable
- ✳ Float switch

APPLICATION LIMITS

- Depth below water level up to **5 m** (with an appropriately sized power cable)
- Liquid temperature up to **+40 °C**
- Capable of processing suspended solids up to **Ø 40 mm**
- Draining capability up to **50 mm** from the bottom
- **Minimum immersion for continuous service: 240 mm**

AVAILABLE UPON REQUEST

- ✳ Pumps with **10 m** power cable.
- ✳ Different voltage requirements 60 Hz frequency

CURVES AND PERFORMANCE DATA

50 Hz

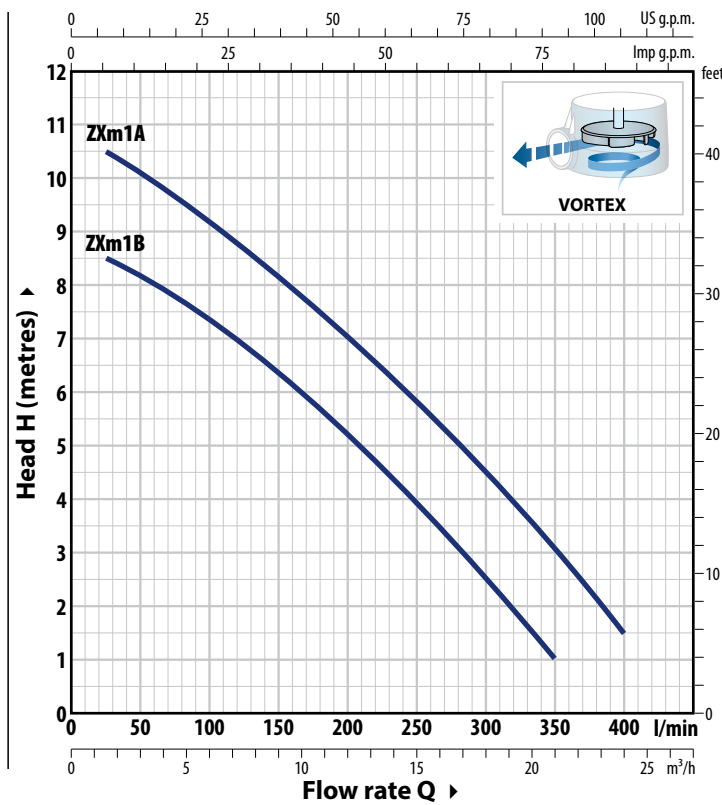

ABSORPTION

TYPE	VOLTAGE
Single-phase	230 V
ZXm 1B/40	3.3 A
ZXm 1A/40	4.5 A

TYPE	POWER (P ₂)		Q	Flow rate												
	kW	HP		m ³ /h	0	1.5	3.0	4.5	6.0	9.0	12.0	15.0	18.0	21.0	24.0	
Single-phase			l/min	0	25	50	75	100	150	200	250	300	350	400		
ZXm 1B/40	0.50	0.70	H metres	9	8.5	8.3	8	7.5	6.5	5.2	4	2.5	1			
ZXm 1A/40	0.60	0.85		11	10.5	10	9.5	9.2	8.2	7	5.7	4.3	2.8	1.5		

Q = Flow rate H = Total manometric head

Performance curves comply with EN ISO 9906 Grade 3B tolerance limits.

MATERIALS AND COMPONENTS

1 Pump body	Cast iron with ISO 228/1 threaded port	
2 Base	Stainless steel AISI 304	
3 Impeller	VORTEX technopolymer type	
4 Outer sleeve	Stainless steel AISI 304	
5 Motor sleeve	Steel	
6 Motor shaft	Stainless steel AISI 431	
7 Double shaft seal		
Seal	Shaft	Materials
STA-12R	Ø 12 mm	Ceramic / Graphite / NBR
Sealing ring	Ø 12 x Ø 22 x H 6 mm	
8 Capacitor		
9 Electric motor		
Single-phase 230 V - 50 Hz with winding integrated thermal motor protection		
– Insulation: class F		
– Protection rating: IP X8		
10 Power cord		
Type 'H07 RN-F' with Schuko plug		
※ Standard length 5 metres		
11 Float switch		
12 Hose holder (included in delivery)		
Ø 50 mm		

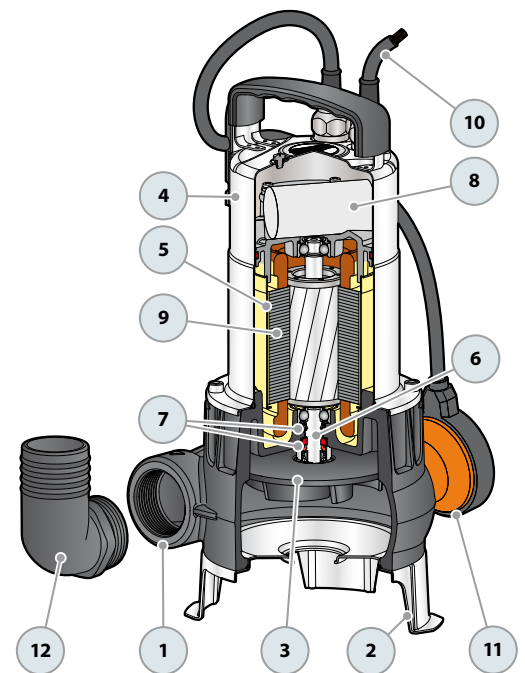

DIMENSIONS AND WEIGHT

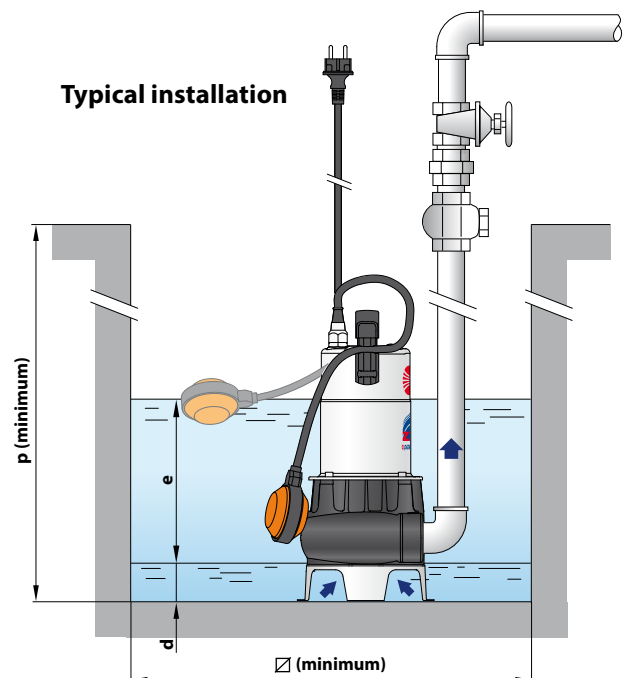
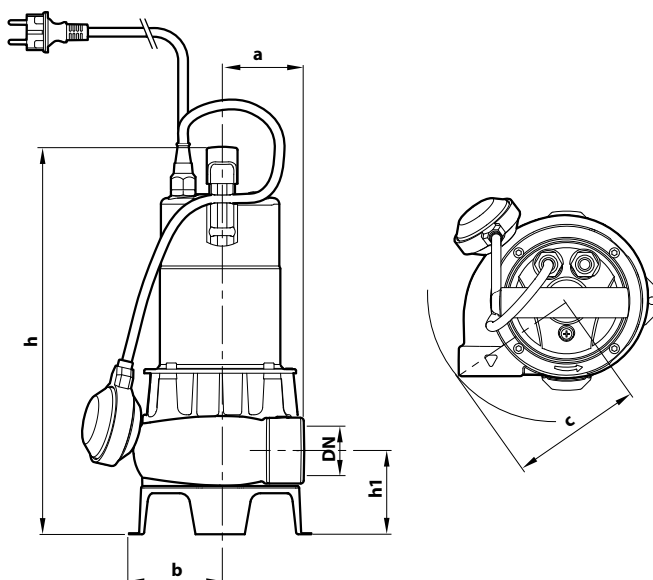

TYPE	PORT DN	Passage of solid bodies	DIMENSIONS mm									kg 1~	PALLET CAPACITY
			a	b	c	h	h1	d	e	p	Ø		
Single-phase													
ZXm 1B/40	1½"	Ø 40 mm	75	89	130	378	82	50	adjustable	450	450	11.6	60
ZXm 1A/40			75	89	130	378	82	50	adjustable	450	450	12.0	60

-  Sewage
-  Domestic use
-  Civil use
-  Industrial use

※ The Go-To Pump for Demanding Conditions and Performance Requirements



PERFORMANCE RANGE

- Flow rate up to **750 l/min** (45 m³/h)
- Head up to **15.5 m**

INSTALLATION AND USE

VX pumps are renowned for their reliability, especially in automated fixed installations.

Ideal for **domestic, civil, and industrial settings**, they efficiently handle suspended solids up to 50 mm in diameter, including in **groundwater, surface water, and sewage**.

They are also perfect for pumping out flooded areas like basements, underground parking garages, car wash stations, and emptying septic tanks and sewage systems.

※ The VORTEX impeller can handle solids up to **50 mm** in diameter. Its unique design ensures safe operation against clogging.

INCLUDES

- ※ Power cable length:
 - **5 m** for VX 8 and VX 10
 - **10 m** for VX 15 and VX 20
- ※ Float switch (exclusive to single-phase models)

APPLICATION LIMITS

- Depth below water level up to **5 m** (with an appropriately sized power cable)
- Liquid temperature up to **+40 °C**
- Suspended solids transfer:
 - up to **Ø 40 mm** for VX /35
 - up to **Ø 50 mm** for VX /50
- **Minimum immersion for continuous service:**
 - **290 mm** for VX 8 and VX 10
 - **330 mm** for VX 15
 - **360 mm** for VX 20

AVAILABLE UPON REQUEST

- ※ Pumps with **10 m** power cable for VX 8 and VX 10
- ※ Different voltage requirements 60 Hz frequency

PATENTS - TRADE MARKS - MODELS

- Patent No. EP2313658
- Patent No. IT0001428923

CURVES AND PERFORMANCE DATA

50 Hz

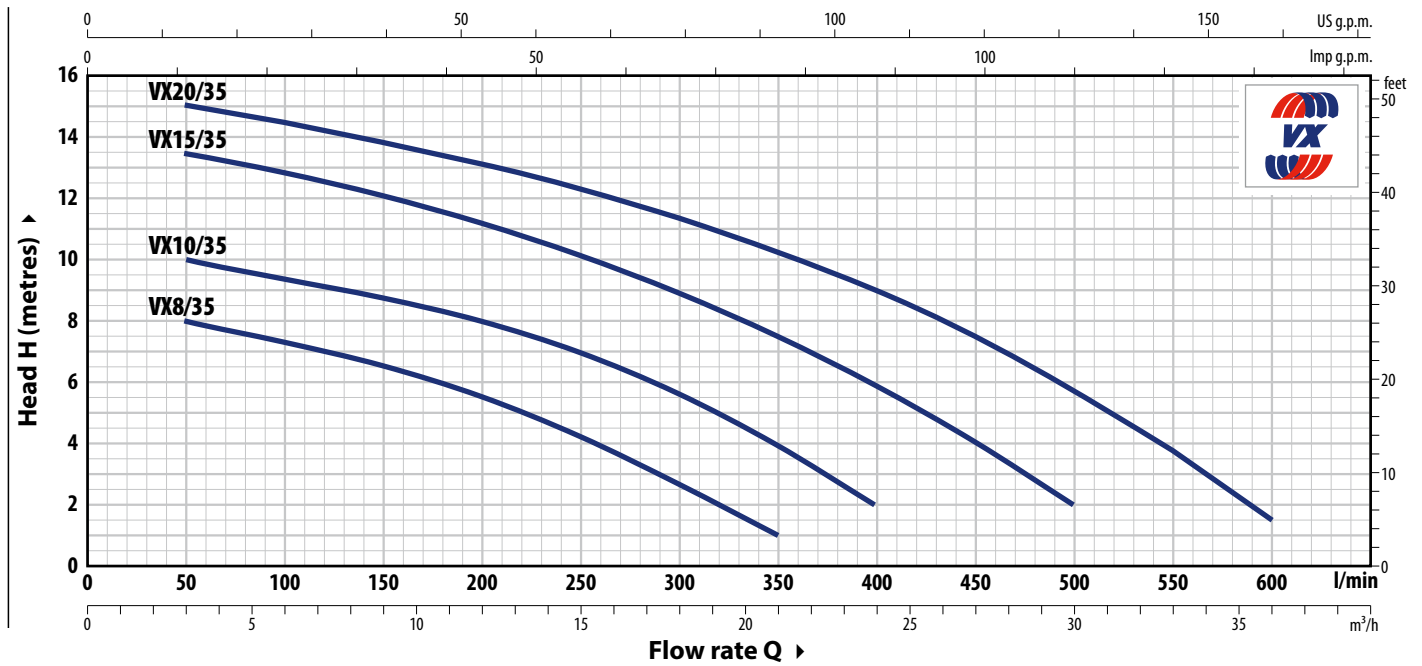

TYPE		POWER (P ₂)		Q	H metres													
Single-phase	Three-phase	kW	HP		m ³ /h	0	3	6	12	18	21	24	27	30	33	36		
				l/min	0	50	100	200	300	350	400	450	500	550	600			
VXm 8/35	VX 8/35	0.55	0.75		9	8	7.5	5.5	2.7	1								
VXm 10/35	VX 10/35	0.75	1		11	10	9.5	8	5.7	4	2							
VXm 15/35	VX 15/35	1.1	1.5		14	13.5	12.8	11.2	9	7.7	6	4	2					
VXm 20/35	VX 20/35	1.5	2		15.5	15	14.5	13	11.5	10.3	9	7.5	5.8	3.8	1.5			

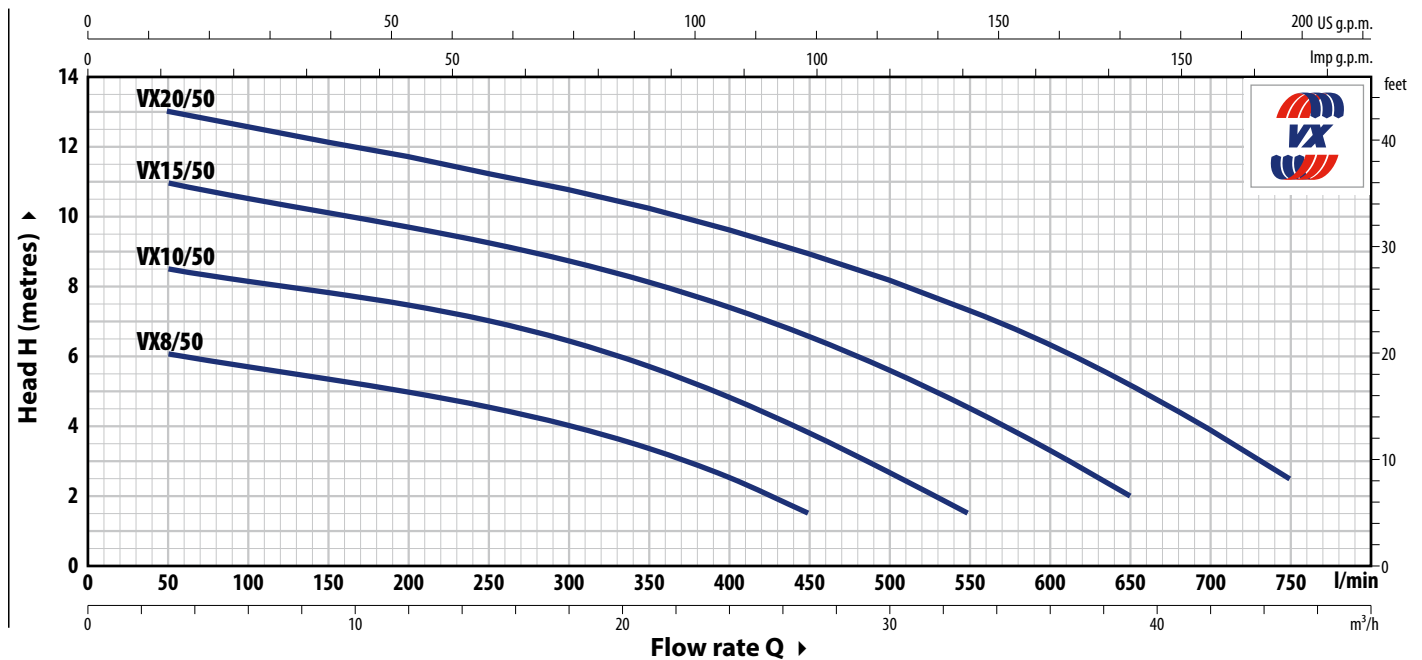

TYPE		POWER (P ₂)		Q	H metres													
Single-phase	Three-phase	kW	HP		m ³ /h	0	3	6	12	18	24	27	30	33	36	39	45	
				l/min	0	50	100	200	300	400	450	500	550	600	650	750		
VXm 8/50	VX 8/50	0.55	0.75		6.5	6	5.8	5	4	2.5	1.5							
VXm 10/50	VX 10/50	0.75	1		9	8.5	8.2	7.5	6.5	5	3.8	2.5	1.5					
VXm 15/50	VX 15/50	1.1	1.5		11.5	11	10.5	9.8	8.7	7.5	6.5	5.5	4.5	3.5	2			
VXm 20/50	VX 20/50	1.5	2		13.5	13	12.5	11.5	10.7	9.5	9	8	7.5	6.5	5	2.5		

Q = Flow rate H = Total manometric head

Performance curves comply with EN ISO 9906 Grade 3B tolerance limits.

ABSORPTION

TYPE	VOLTAGE
Single-phase	230 V
VXm 8/35	4.3 A
VXm 10/35	5.5 A
VXm 15/35	7.0 A
VXm 20/35	9.6 A
VXm 8/50	4.3 A
VXm 10/50	5.5 A
VXm 15/50	7.0 A
VXm 20/50	9.6 A

TYPE	VOLTAGE
Three-phase	400 V
VX 8/35	1.6 A
VX 10/35	2.2 A
VX 15/35	2.7 A
VX 20/35	3.7 A
VX 8/50	1.6 A
VX 10/50	2.2 A
VX 15/50	2.7 A
VX 20/50	3.7 A

DIMENSIONS AND WEIGHT

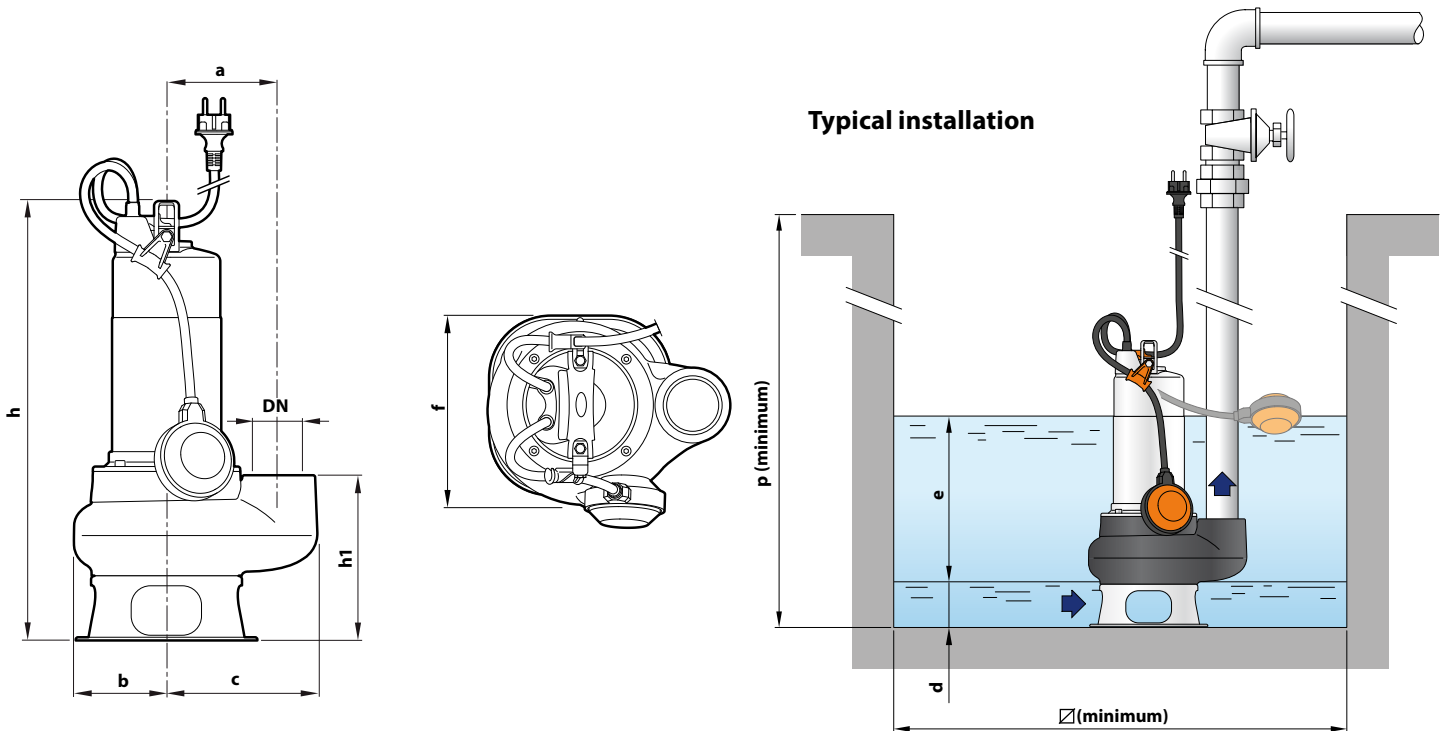

TYPE		PORT DN	Passage of solid bodies	DIMENSIONS mm										kg	
Single-phase	Three-phase			a	b	c	f	h	h1	d	e	p	Ø	1~	3~
VXm 8/35	VX 8/35	1½"	Ø 40 mm	115	95	148	200	425	158	55	adjustable	500	500	13.7	12.6
VXm 10/35	VX 10/35							440						15.2	14.0
VXm 15/35	VX 15/35							473						18.0	16.4
VXm 20/35	VX 20/35							503						20.2	18.0
VXm 8/50	VX 8/50	2"	Ø 50 mm	115	95	155	200	436	169	60	adjustable	500	500	14.2	13.1
VXm 10/50	VX 10/50							451						15.7	14.5
VXm 15/50	VX 15/50							484						18.5	16.9
VXm 20/50	VX 20/50							514						20.7	18.5

PALLET CAPACITY

TYPE		NO. OF PUMPS
Single-phase	Three-phase	
VXm 8/35	VX 8/35	45
VXm 10/35	VX 10/35	45
VXm 15/35	VX 15/35	30
VXm 20/35	VX 20/35	30
VXm 8/50	VX 8/50	45
VXm 10/50	VX 10/50	45
VXm 15/50	VX 15/50	30
VXm 20/50	VX 20/50	30

MATERIALS AND COMPONENTS

1 Pump body	Cast iron with cathaphoresis treatment for greater corrosion resistance with ISO 228/1 threaded port		
2 Base	Stainless steel AISI 304		
3 Impeller	VORTEX type in AISI 304 stainless steel.		
4 Motor sleeve	Stainless steel AISI 304		
5 Motor cover	AISI 304 stainless steel for VX 8-10 Cast iron with cathaphoresis treatment for VX 15-20		
6 Motor shaft	Stainless steel AISI 431		
7 Double mechanical seal in oil chamber			
Seal	Shaft	Location	Materials
MG1-14D SIC	Ø 14 mm	Motor side Pump side	Silicon carbide / Graphite / NBR Silicon carbide/Silicon carbide/NBR
8 Capacitor	(exclusive to single-phase models)		
9 Electric motor			
VXm:	single-phase 230 V - 50 Hz with winding integrated thermal motor protection		
VX:	three-phase 400 V - 50 Hz		
	– Insulation: class F		
	– Protection rating: IP X8		
10 Power cord			
	Power cable encapsulated with epoxy resin both in the grommet area and where the conductors exit the sheath, for absolute insulation against moisture and water.		
	Type 'H07 RN-F (Schuko plug exclusive to single-phase models) ※ Standard length 5 metres (10 metres for VX 15 and VX 20)		
11 Float switch	(exclusive to single-phase models)		
12 Tilting device for the float cable	(exclusive to single-phase models) Patent No. IT0001428923		
13 Power cable strain relief	Patent No. EP2313658		

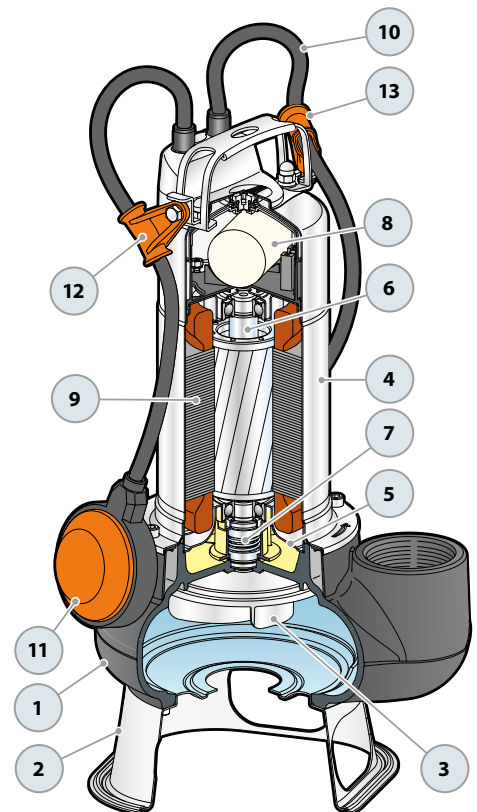

-  Sewage
-  Domestic use
-  Civil use
-  Industrial use

※ **BC: The Ultimate Pump for Demanding Conditions and Maximum Performance**



PERFORMANCE RANGE

- Flow rate up to **850 l/min** (51 m³/h)
- Head up to **17 m**

INSTALLATION AND USE

BC submersible pumps are designed to drain **dirty and sewage water** in **domestic, civil, and industrial settings**. Featuring a **TWO-CHANNEL** stainless steel impeller, they can efficiently pump liquids containing suspended solids up to **50 mm in diameter** with short fibers and handle wastewater, sewage, surface water, and sludge-mixed water in residential properties.

※ The **TWO-CHANNEL** impeller provides excellent performance and high energy efficiency, generating increased pressure for pumping solids up to **50 mm in diameter**, making it the best choice for wastewater drainage.

INCLUDES

- ※ Power cable length:
 - **5 m** for BC 10
 - **10 m** for BC 15 and BC 20
- ※ Float switch (exclusive to single-phase models)

APPLICATION LIMITS

- Depth below water level up to **5 m** (with an appropriately sized power cable)
- Liquid temperature up to **+40 °C**
- Capable of processing suspended solids up to **Ø 50 mm**
- **Minimum immersion for continuous service:**
 - **290 mm for BC 10/50**
 - **330 mm for BC 15/50**
 - **360 mm for BC 20/50**

AVAILABLE UPON REQUEST

- ※ Pumps with **10 m** power cable for BC 10
- ※ Different voltage requirements 60 Hz frequency

PATENTS - TRADE MARKS - MODELS

- Patent No. EP2313658
- Patent No. IT0001428923

CURVES AND PERFORMANCE DATA

50 Hz

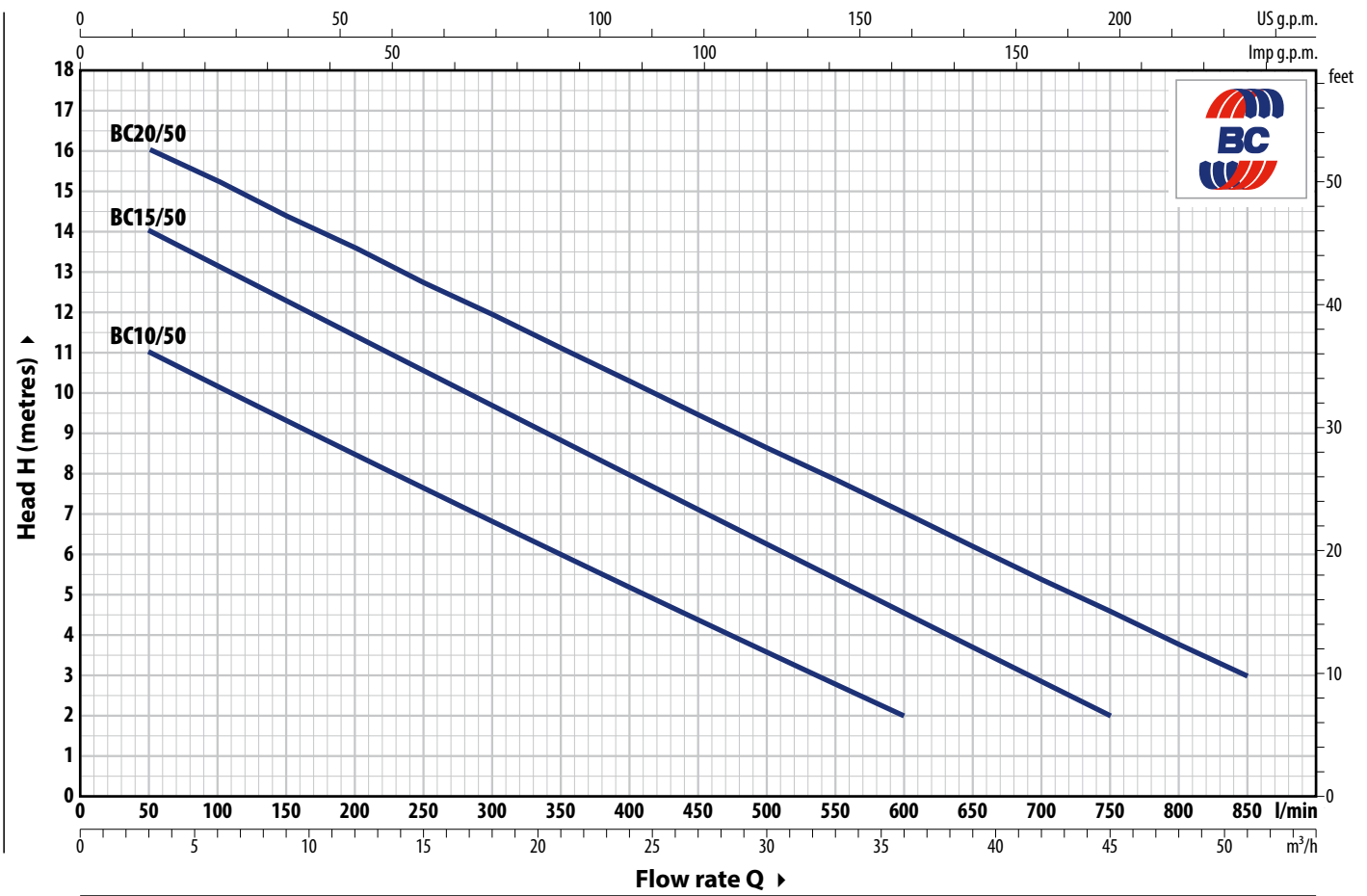

TYPE		POWER (P ₂)		Q	Flow rate														
Single-phase	Three-phase	kW	HP		m ³ /h	0	3	6	12	18	24	30	36	42	45	51			
				l/min	0	50	100	200	300	400	500	600	700	750	850				
BCm 10/50	BC 10/50	0.75	1	H metres	12	11	10	8.5	7	5	3.6	2							
BCm 15/50	BC 15/50	1.1	1.5		15	14	13	11.5	9.7	8	6.3	4.6	3	2					
BCm 20/50	BC 20/50	1.5	2		17	16	15.3	13.5	12	10.3	8.6	7.0	5.3	4.5	3				

Q = Flow rate H = Total manometric head

Performance curves comply with EN ISO 9906 Grade 3B tolerance limits.

ABSORPTION

TYPE	VOLTAGE
Single-phase	230 V
BCm 10/50	5.5 A
BCm 15/50	8.0 A
BCm 20/50	10.0 A

TYPE	VOLTAGE
Three-phase	400 V
BC 10/50	2.2 A
BC 15/50	3.1 A
BC 20/50	3.9 A

DIMENSIONS AND WEIGHT

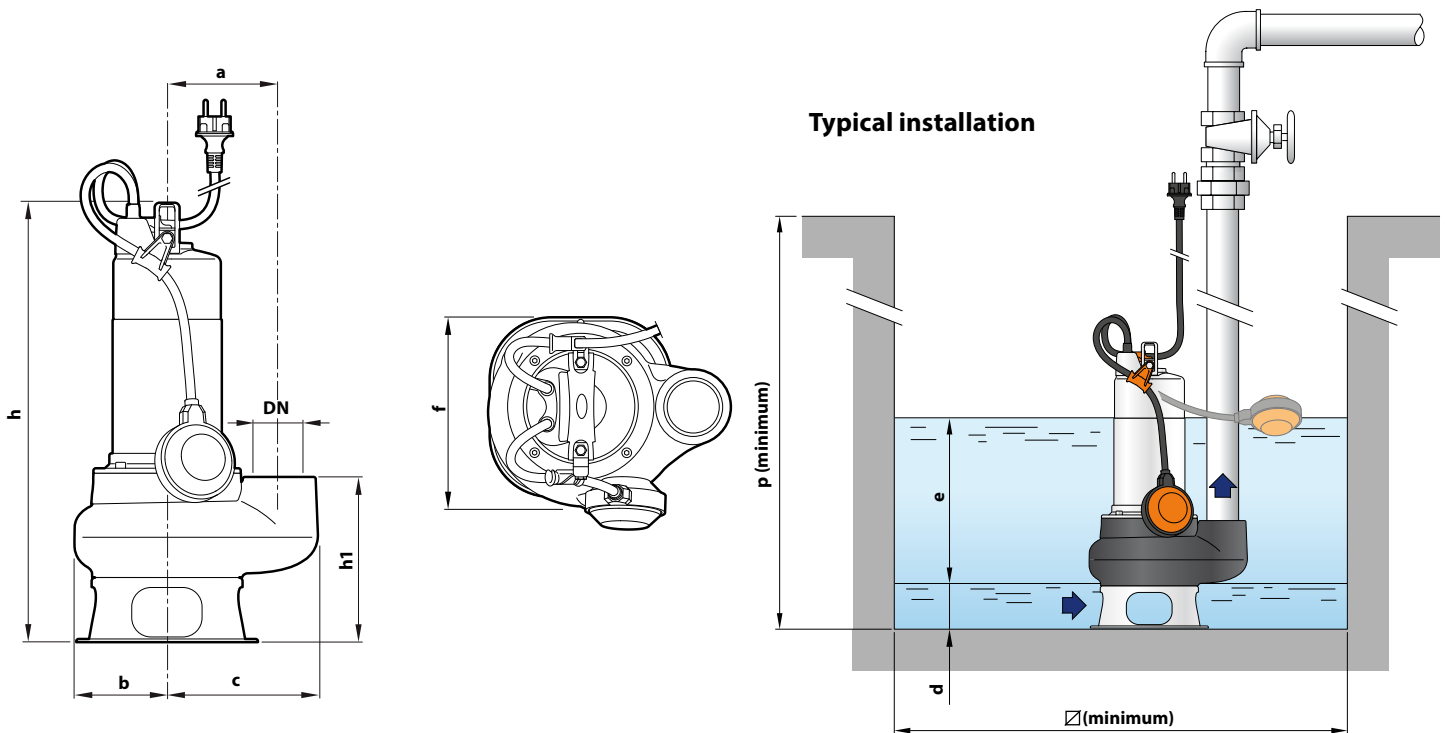

TYPE		PORT DN	Passage of solid bodies	DIMENSIONS mm										kg	
Single-phase	Three-phase			a	b	c	f	h	h1	d	e	p	Ø	1~	3~
BCm 10/50	BC 10/50	2"	Ø 50 mm	115	95	155	200	451	169	60	adjustable	500	500	16.2	15.0
BCm 15/50	BC 15/50							484						18.8	17.2
BCm 20/50	BC 20/50							514						21.0	18.8

PALLET CAPACITY

TYPE		NO. OF PUMPS
Single-phase	Three-phase	
BCm 10/50	BC 10/50	45
BCm 15/50	BC 15/50	30
BCm 20/50	BC 20/50	30

MATERIALS AND COMPONENTS

1 Pump body	Cast iron with cathoporesis treatment for greater corrosion resistance with ISO 228/1 threaded port												
2 Base	Stainless steel AISI 304												
3 Impeller	TWO-CHANNEL type in micro-cast AISI 304 stainless steel.												
4 Motor sleeve	Stainless steel AISI 304												
5 Motor cover	AISI 304 stainless steel for BC 10/50 Cast iron with cathoporesis treatment for BC 15/50, BC 20/50												
6 Motor shaft	Stainless steel AISI 431												
7 Double mechanical seal in oil chamber	<table border="1"> <thead> <tr> <th>Seal</th> <th>Shaft</th> <th>Location</th> <th>Materials</th> </tr> </thead> <tbody> <tr> <td rowspan="2">MG1-14D SIC</td> <td rowspan="2">Ø 14 mm</td> <td>Motor side</td> <td>Silicon carbide / Graphite / NBR</td> </tr> <tr> <td>Pump side</td> <td>Silicon carbide/Silicon carbide/NBR</td> </tr> </tbody> </table>			Seal	Shaft	Location	Materials	MG1-14D SIC	Ø 14 mm	Motor side	Silicon carbide / Graphite / NBR	Pump side	Silicon carbide/Silicon carbide/NBR
Seal	Shaft	Location	Materials										
MG1-14D SIC	Ø 14 mm	Motor side	Silicon carbide / Graphite / NBR										
		Pump side	Silicon carbide/Silicon carbide/NBR										
8 Capacitor	(exclusive to single-phase models)												
9 Electric motor	<p>BCm: single-phase 230 V - 50 Hz with winding integrated thermal motor protection</p> <p>BC: three-phase 400 V - 50 Hz</p> <p>– Insulation: class F</p> <p>– Protection rating: IP X8</p>												
10 Power cord	<p>Power cable encapsulated with epoxy resin both in the grommet area and where the conductors exit the sheath, for absolute insulation against moisture and water.</p> <p>Type 'H07 RN-F (Schuko plug exclusive to single-phase models)</p> <p>※ Standard length 5 metres (10 metres for BC 15 and BC 20)</p>												
11 Float switch	(exclusive to single-phase models)												
12 Tilting device for the float cable	(exclusive to single-phase models) Patent No. IT0001428923												
13 Power cable strain relief	Patent No. EP2313658												

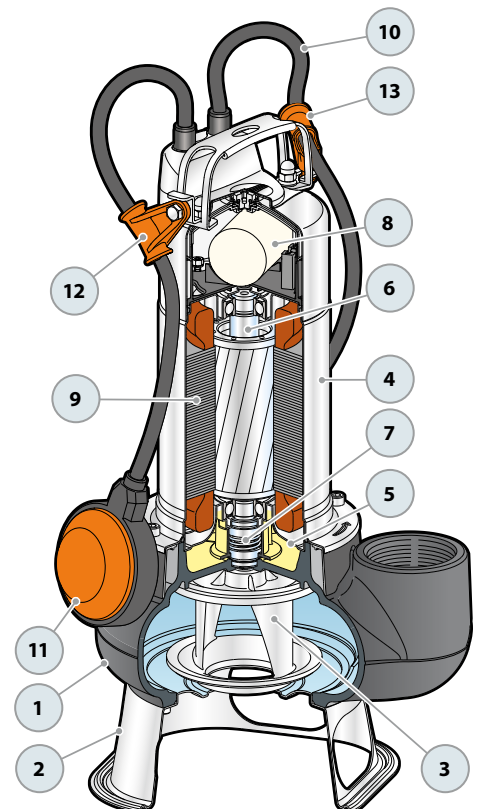



Sewage



Domestic use



Civil use

※ **High-quality materials and robust construction ensure superior performance and reliability**



PERFORMANCE RANGE

- Flow rate up to **650 l/min** (39 m³/h)
- Head up to **14 m**

INSTALLATION AND USE

The **VXC** series features **VORTEX**-type impellers, offering robust and reliable performance for demanding applications. Constructed from thick cast iron, these pumps are exceptionally strong and resistant to abrasion, ensuring continuous operation.

They are perfectly suited for draining **dirty water with suspended solids and sewage, wastewater, and sludge mixtures**.

INCLUDES

- ※ Power cable length **10 m**
- ※ Float switch (exclusive to single-phase models)

APPLICATION LIMITS

- Depth below water level up to **10 m** (with an appropriately sized power cable)
- Liquid temperature up to **+40 °C**
- Suspended solids transfer:
 - up to **Ø 40 mm** for VXC /35
 - up to **Ø 50 mm** for VXC /45
- **Minimum immersion for continuous service 305 mm**

AVAILABLE UPON REQUEST

- ※ Different voltage requirements 60 Hz frequency

PATENTS - TRADE MARKS - MODELS

- Patent No. IT0001428923
- Registered Community Model No. 002501486-0003

CURVES AND PERFORMANCE DATA

50 Hz

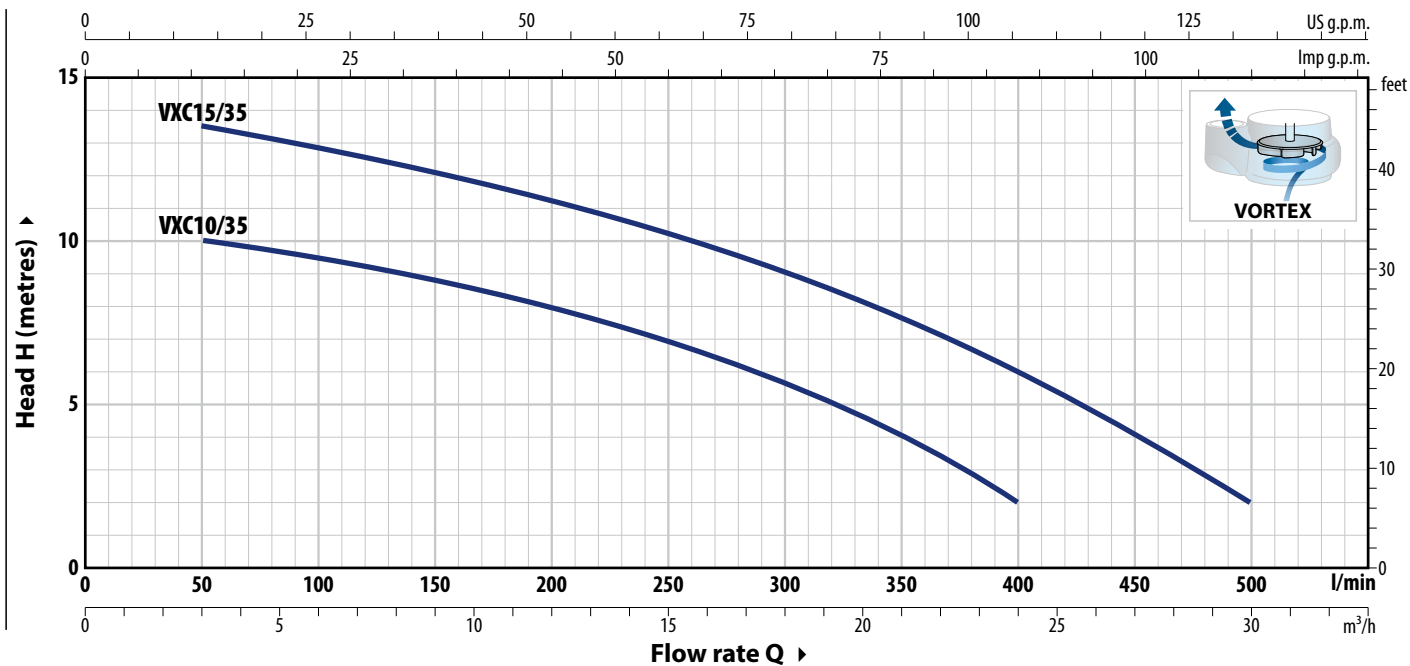

TYPE		POWER (P ₂)		Q	m ³ /h												
Single-phase	Three-phase	kW	HP		0	3	6	12	18	21	24	27	30				
VXCm 10/35	VXC 10/35	0.75	1	l/min	0	50	100	200	300	350	400	450	500				
VXCm 15/35	VXC 15/35	1.1	1.5	H metres	11	10	9.5	8	5.7	4	2						
					14	13.5	12.8	11.2	9	7.7	6	4	2				

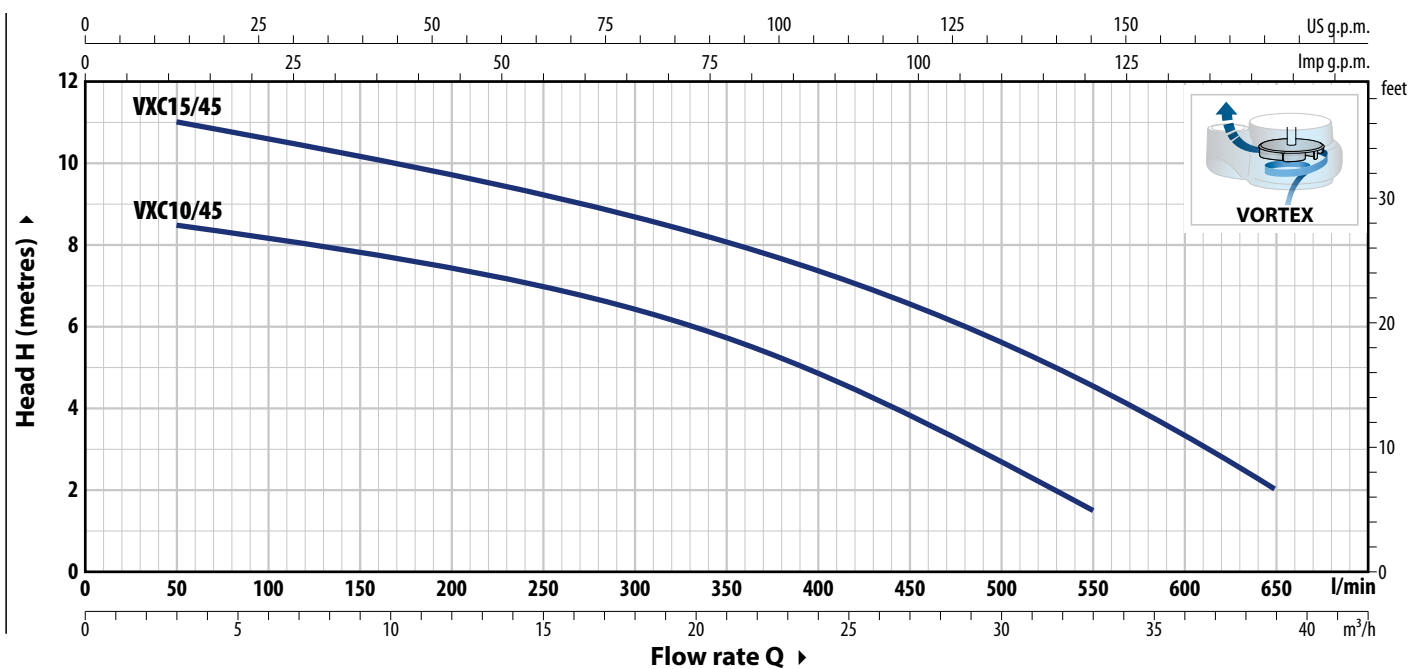

TYPE		POWER (P ₂)		Q	m ³ /h												
Single-phase	Three-phase	kW	HP		0	3	6	12	18	24	27	30	33	36	39		
VXCm 10/45	VXC 10/45	0.75	1	l/min	0	50	100	200	300	400	450	500	550	600	650		
VXCm 15/45	VXC 15/45	1.1	1.5	H metres	9	8.5	8.2	7.5	6.5	5	3.8	2.5	1.5				
					11.5	11	10.5	9.8	8.7	7.5	6.5	5.5	4.5	3.5	2		

Q = Flow rate H = Total manometric head

Performance curves comply with EN ISO 9906 Grade 3B tolerance limits.

ABSORPTION

TYPE	VOLTAGE
Single-phase	230 V
VXCm 10/35	5.5 A
VXCm 15/35	7.4 A
VXCm 10/45	5.5 A
VXCm 15/45	7.4 A

TYPE	VOLTAGE
Three-phase	400 V
VXC 10/35	2.2 A
VXC 15/35	3.0 A
VXC 10/45	2.2 A
VXC 15/45	3.0 A

DIMENSIONS AND WEIGHT

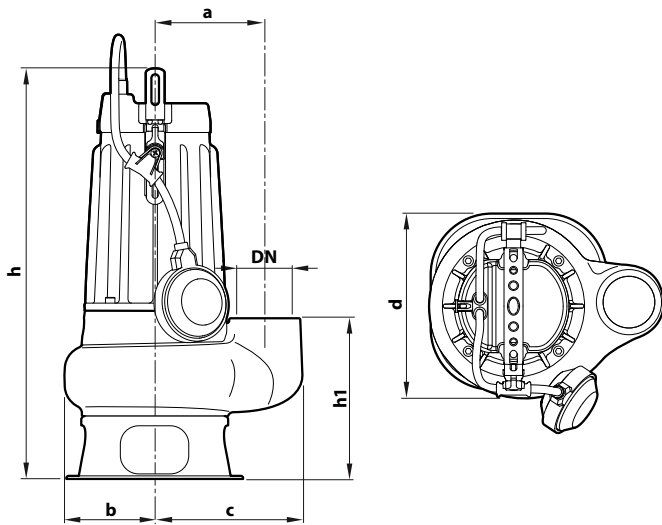

Typical installation

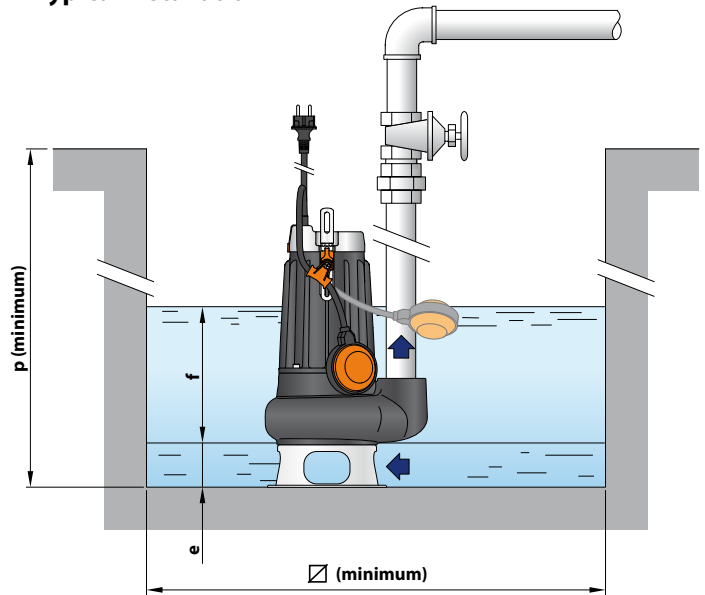

TYPE		PORT DN	Passage of solid bodies	DIMENSIONS mm										kg	
Single-phase	Three-phase			a	b	c	d	h	h1	e	f	p	Ø	1~	3~
VXCm 10/35	VXC 10/35	1½"	Ø 40 mm	115	95	148	200	421	158	55	adjustable	500	500	19.6	18.2
VXCm 15/35	VXC 15/35					19.7		18.3							
VXCm 10/45	VXC 10/45	2"	Ø 50 mm			155		434	169	60				20.1	19.0
VXCm 15/45	VXC 15/45					20.2		19.1							

PALLET CAPACITY

TYPE	NO. OF PUMPS
Three-phase	
VXC 10/35	45
VXC 15/35	45
VXC 10/45	45
VXC 15/45	45

MATERIALS AND COMPONENTS

1 Pump body	Cast iron with cataphoresis treatment for greater corrosion resistance with ISO 228/1 threaded port
2 Base	Stainless steel AISI 304
3 Impeller	VORTEX type in AISI 304 stainless steel
4 Motor holder	Cast iron with cataphoresis treatment
5 Motor cover	Stainless steel AISI 304
6 Motor shaft	Stainless steel AISI 431

7 Double mechanical seal with interposed oil chamber

Seal	Shaft	Location	Materials
MG1-14D SIC	Ø 14 mm	Motor side Pump side	Silicon carbide / Graphite / NBR Silicon carbide/Silicon carbide/NBR

8 Electric motor

- VXCm:** single-phase 230 V - 50 Hz
with winding integrated thermal motor protection
- VXC:** three-phase 400 V - 50Hz
- Insulation: class F
 - Protection rating: IP X8

9 Power cord

- Type 'H07 RN-F
(Schuko plug exclusive to single-phase models)
- ※ Standard length 10 metres

10 Float switch

(exclusive to single-phase models)

11 Tilting device for the float cable

(exclusive to single-phase models)
Patent No. IT0001428923

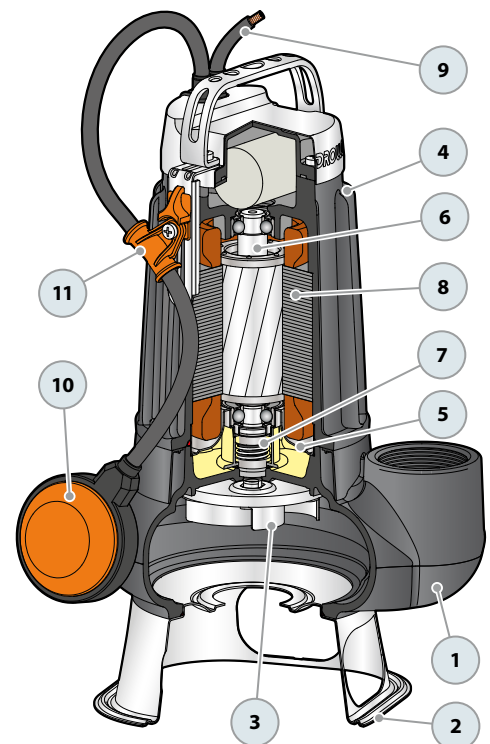



Sewage



Domestic use



Civil use



PERFORMANCE RANGE

- Flow rate up to **750 l/min** (45 m³/h)
- Head up to **15 m**

INSTALLATION AND USE

The **MC** series features **TWO-CHANNEL** impellers, offering **robust** and reliable performance for demanding applications. Constructed from thick cast iron, these pumps are exceptionally strong and resistant to abrasion, ensuring continuous operation.

They are perfectly suited for draining **dirty water with suspended solids, and sewage**.

INCLUDES

- ✳ Power cable length **10 m**
- ✳ Float switch (exclusive to single-phase models)

APPLICATION LIMITS

- Depth below water level up to **10 m** (with an appropriately sized power cable)
- Liquid temperature up to **+40 °C**
- Capable of processing suspended solids up to **Ø 50 mm**
- **Minimum immersion for continuous service: 305 mm**

AVAILABLE UPON REQUEST

- ✳ Different voltage requirements 60 Hz frequency

PATENTS - TRADE MARKS - MODELS

- Patent No. IT0001428923
- Registered Community Model No. 002501486-0003

ABSORPTION

TYPE	VOLTAGE
Single-phase	230 V
MCm 10/45	5.0 A
MCm 15/45	8.2 A
TYPE	VOLTAGE
Three-phase	400 V
MC 10/45	2.1 A
MC 15/45	3.2 A

CURVES AND PERFORMANCE DATA

50 Hz

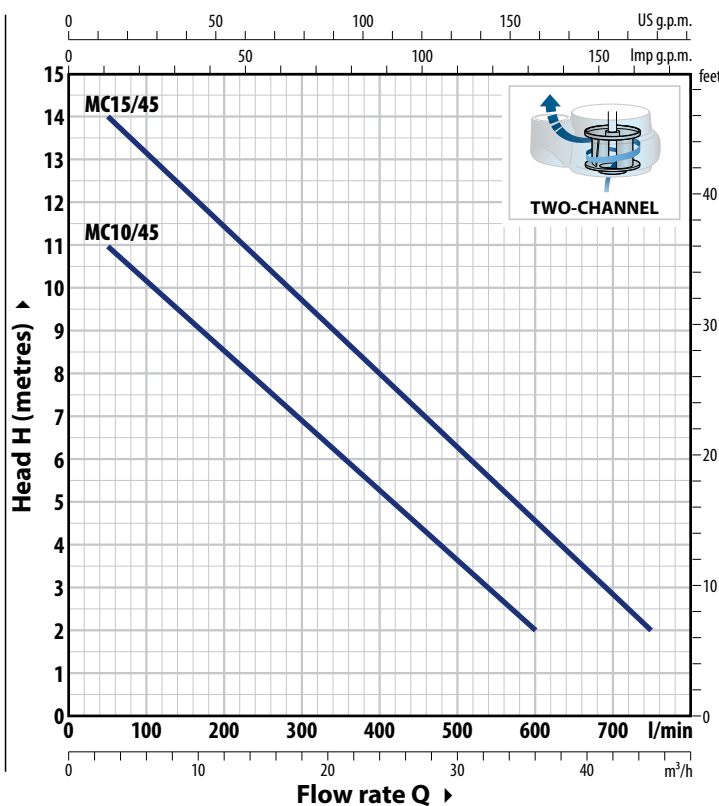

TYPE		POWER (P ₂)		Q	Flow rate													
Single-phase	Three-phase	kW	HP		m ³ /h	0	3	6	12	18	24	30	36	42	45			
MCm 10/45	MC 10/45	0.75	1	H metres	0	50	100	200	300	400	500	600	700	750				
MCm 15/45	MC 15/45	1.1	1.5		12	11	10	8.5	7	5	3.5	2						
					15	14	13	11.5	9.7	8	6.3	4.5	3	2				

Q = Flow rate H = Total manometric head

Performance curves comply with EN ISO 9906 Grade 3B tolerance limits.

MATERIALS AND COMPONENTS

1 Pump body	Cast iron with cathaphoresis treatment for greater corrosion resistance with ISO 228/1 threaded port		
2 Base	Stainless steel AISI 304		
3 Impeller	Two-channel type in micro-cast AISI 304 stainless steel		
4 Motor holder	Cast iron with cathaphoresis treatment		
5 Motor cover	Stainless steel AISI 304		
6 Motor shaft	Stainless steel AISI 431		
7 Double mechanical seal with interposed oil chamber			
Seal	Shaft	Location	Materials
MG1-14D SIC	Ø 14 mm	Motor side	SiC / Graphite / NBR
		Pump side	SiC / SiC / NBR
8 Electric motor			
MCm	single-phase 230 V - 50 Hz with winding integrated thermal motor protection		
MC	three-phase 400 V - 50Hz – Insulation: class F – Protection rating: IP X8		
9 Power cord			
	Type 'H07 RN-F' (Schuko plug exclusive to single-phase models) ※ Standard length 10 metres		
10 Float switch	(exclusive to single-phase models)		
11 Tilting device for the float cable	(exclusive to single-phase models) Patent No. IT0001428923		

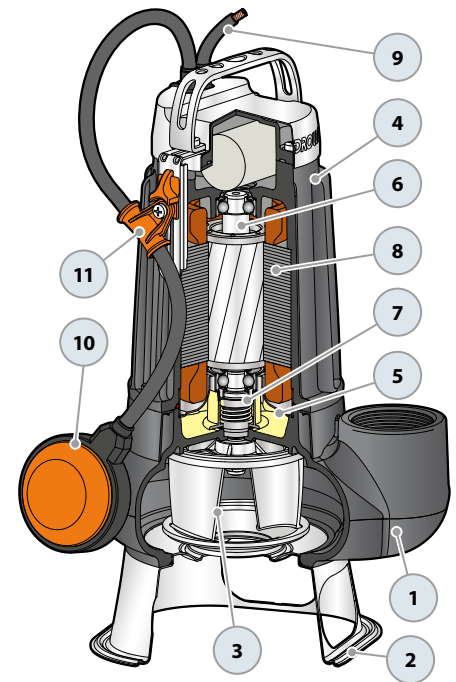

DIMENSIONS AND WEIGHT

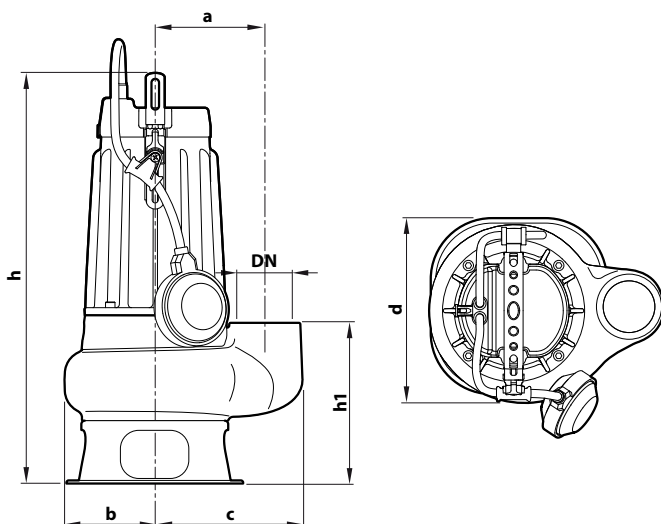

Typical installation

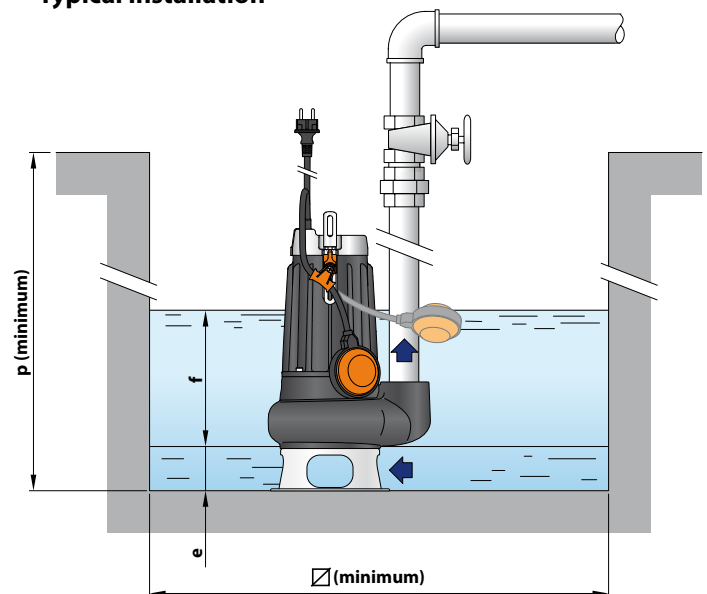

TYPE		PORT DN	Passage of solid bodies	DIMENSIONS mm										kg		PALLET CAPACITY
Single-ph.	Three-ph			a	b	c	d	h	h1	e	f	p	Ø	1~	3~	
MCm 10/45	MC 10/45	2"	Ø 50 mm	115	95	155	200	434	169	60	adjustable	500	500	19.2	17.7	45
MCm 15/45	MC 15/45			20.1	19.3	45										

-  Clear waters
-  Domestic use
-  Civil use
-  Industrial use

※ **High-quality materials and robust construction ensure superior performance and reliability**



PERFORMANCE RANGE

- Flow rate up to **550 l/min** (33 m³/h)
- Head up to **38 m**

INSTALLATION AND USE

DC submersible pumps are constructed from thick cast iron, offering exceptional robustness, abrasion resistance, and longevity. Perfect for **draining both clear and slightly dirty water**, their durability and reliability set them apart. Designed for automated fixed installations, the DC series guarantees continuous operation, even in conditions where they are not fully submerged.

INCLUDES

- ※ Power cable length **10 m**
- ※ Float switch (exclusive to single-phase models)
- ※ Switchbox compatible with DCm42, DCm43 (exclusive to single-phase models)

APPLICATION LIMITS

- Maximum operating depth below water level up to **10 m** (with an appropriately sized power cable)
- Liquid temperature up to **+40 °C**
- Capable of processing suspended solids up to **Ø 10 mm**
- Draining capability:
 - up to **17 mm** from the bottom for DC 10-20-30
 - up to **25 mm** from the bottom for DC 42-43-44
- **Minimum immersion for continuous service:**
 - **220 mm DC 10-20-30**
 - **300 mm DC 42-43-44**

AVAILABLE UPON REQUEST

- ※ Different voltage requirements 60 Hz frequency

WARRANTY

- ※ **The warranty for the Three-Phase DC 42-43-44 models remains valid only if the motor's built-in thermal protector is properly connected to the control panel. This connection is essential for the warranty's applicability**

PATENTS - TRADE MARKS - MODELS

- Patent No. IT0001428923
- Registered Community Model No. 002501486-0001

CURVES AND PERFORMANCE DATA

50 Hz

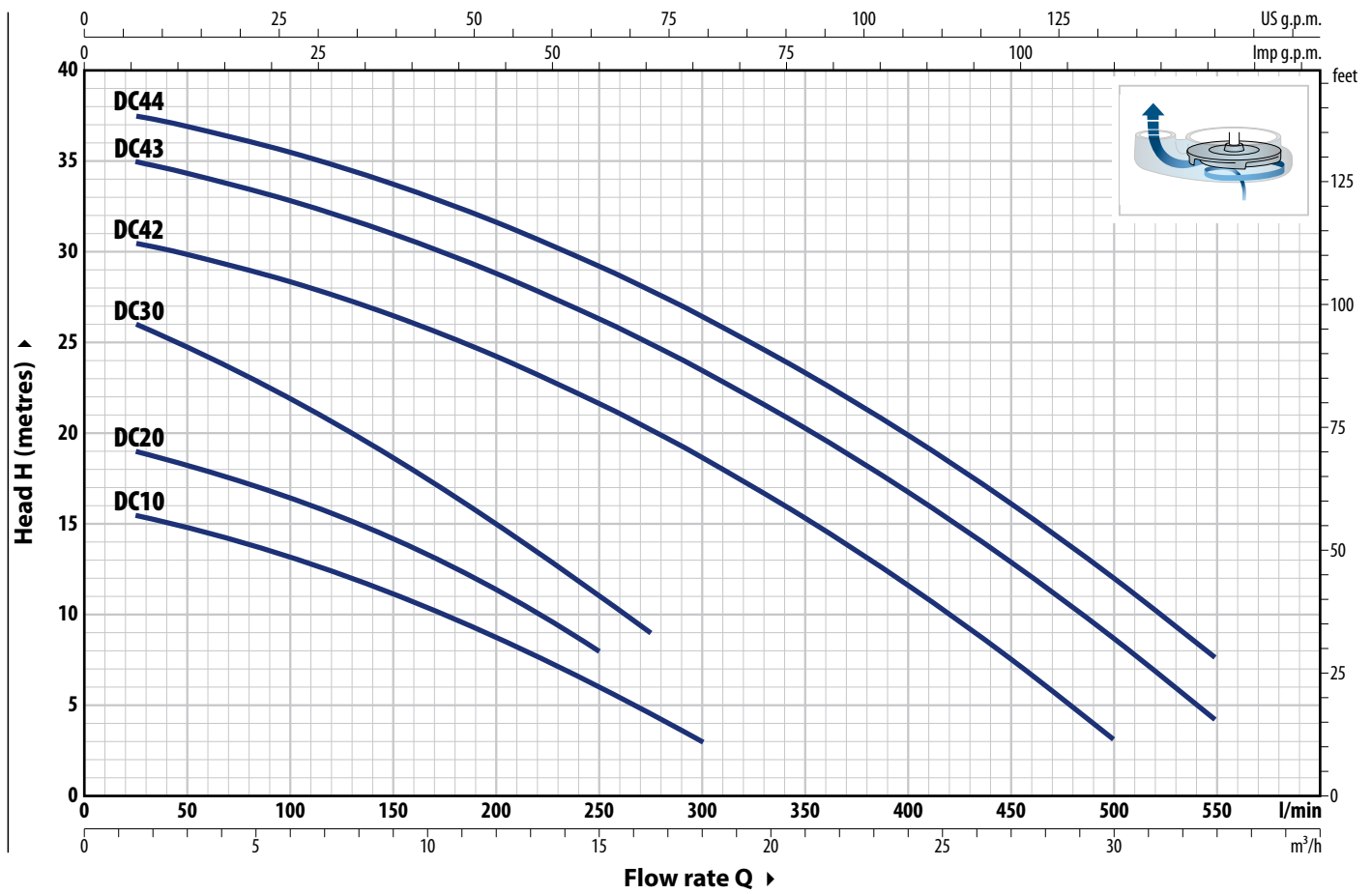

TYPE		POWER (P ₂)		Q	Flow rate																	
Single-ph.	Three-ph.	kW	HP		m ³ /h	0	1.5	3.0	6.0	9.0	12.0	15.0	16.5	18.0	21.0	24.0	27.0	30.0	33.0			
				l/min	0	25	50	100	150	200	250	275	300	350	400	450	500	550				
DCm 10	DC 10	0.75	1	H metres	16	15.5	14.8	13.2	11.2	8.8	6	4.5	3									
DCm 20	DC 20	0.75	1		20	19	18.5	16.5	14.3	11.5	8											
DCm 30	DC 30	1.1	1.5		26	26	24.8	22	18.7	15	11	9										
DCm 42	DC 42	1.5	2		31	30.5	30	28.4	26.5	24.3	21.6	20.2	18.6	15.3	11.6	7.5	3					
DCm 43	DC 43	2.2	3		35.5	35	34.4	33	31	28.8	26.3	25	23.5	20.3	16.7	12.8	8.5	4				
-	DC 44	3	4		38	37.5	37	35.5	33.7	31.6	29.2	27.8	26.4	23.3	20	16	12	7.5				

Q = Flow rate H = Total manometric head

Performance curves comply with EN ISO 9906 Grade 3B tolerance limits.

ABSORPTION

TYPE	VOLTAGE
Single-phase	230 V
DCm 10	5.0 A
DCm 20	5.7 A
DCm 30	7.2 A
DCm 42	13.0 A
DCm 43	16.0 A

TYPE	VOLTAGE
Three-phase	400 V
DC 10	2.0 A
DC 20	2.4 A
DC 30	3.0 A
DC 42	5.2 A
DC 43	6.2 A
DC 44	6.8 A

DIMENSIONS AND WEIGHT

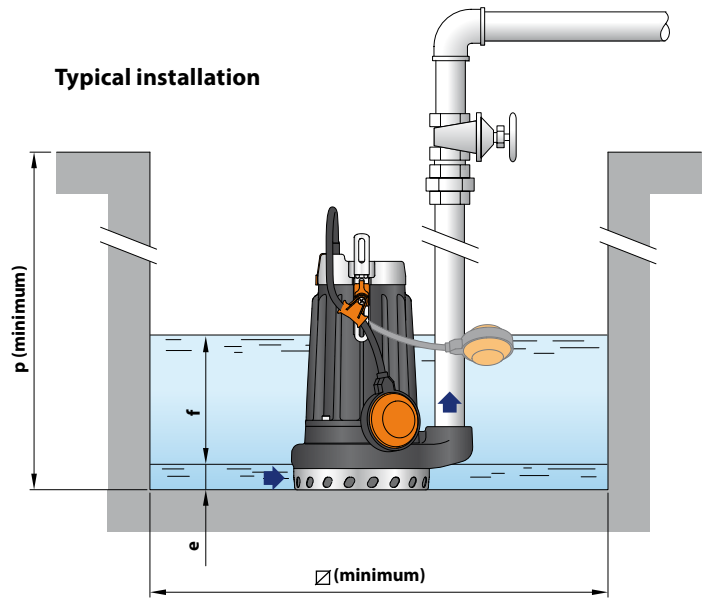
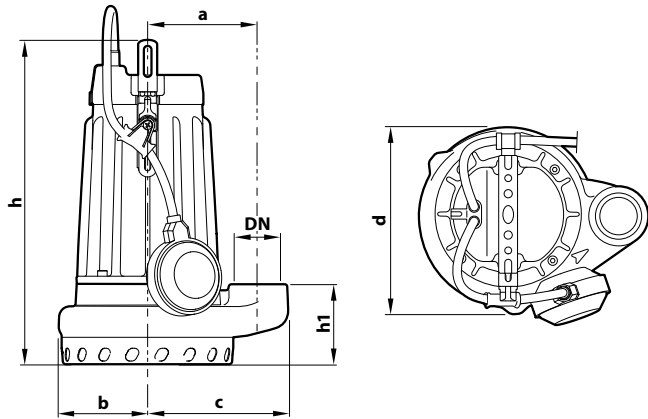

TYPE		PORT DN	DIMENSIONS mm										kg	
Single-ph.	Three-ph.		a	b	c	d	h	h1	e	f	p	Ø	1~	3~
DCm 10	DC 10	1½"	115	85	147	177	336	73	17	adjustable	500	500	16.9	15.8
DCm 20	DC 20			93									16.9	15.9
DCm 30	DC 30			19.0	17.7									

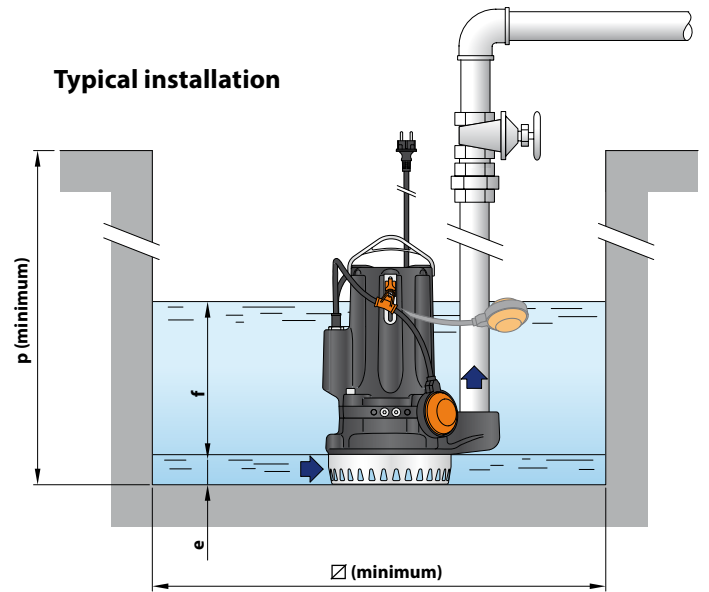
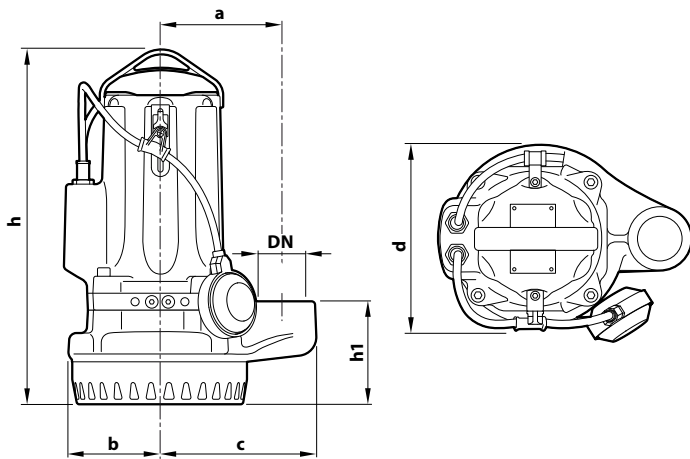

TYPE		PORT DN	DIMENSIONS mm										kg	
Single-ph.	Three-ph.		a	b	c	d	h	h1	e	f	p	Ø	1~	3~
DCm 42	DC 42	2"	150	112	190	230	434	125	25	adjustable	800	800	42.0	41.0
DCm 43	DC 43						460 434						47.0	42.0
-	DC 44						460						-	47.0

PALLET CAPACITY

TYPE		NO. OF PUMPS
Single-ph.	Three-ph.	
DCm 10	DC 10	60
DCm 20	DC 20	60
DCm 30	DC 30	60

TYPE		NO. OF PUMPS
Single-ph.	Three-ph.	
DCm 42	DC 42	16
DCm 43	DC 43	16
-	DC 44	16

MATERIALS AND COMPONENTS

DC 10-20-30

1 Pump body	Cast iron with cataphoresis
2 Grid	Stainless steel AISI 304
3 Cover	Stainless steel AISI 304
4 Impeller	Open type in technopolymer
5 Motor holder	Cast iron with cataphoresis
6 Motor cover	Stainless steel AISI 304
7 Motor shaft	Stainless steel AISI 431

8 Double mechanical seal in oil chamber

Pump	Seal	Shaft	Materials
DC10	MG1-14D SIC	Ø 14 mm	SiC / Graphite / NBR
DC20			SiC / SiC / NBR
Double shaft seal with sealing ring Ø 16 x Ø 24 x H 5 mm			
DC30	ST1-14 SIC	Ø 14 mm	Ceramic / C. silicon / NBR

9 Electric Motor

DCm :single-phase 230 V - 50 Hz
with thermal motor protection

DC : three-phase 400 V - 50Hz
– Insulation: class F – Protection rating: IP X8

10 Power cord

(Schuko plug exclusive to single-phase models)
※ 10 metres 'H07 RN-F' type

11 Float switch

12 Tilting device for the float cable

(exclusive to single-ph. models) Patent No. IT0001428923

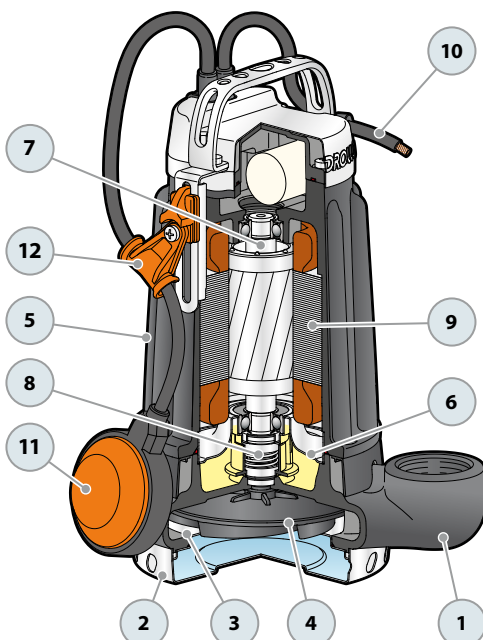

DC 42-43-44

1 Pump body	Cast iron with cataphoresis
2 Grid	Stainless steel AISI 304
3 Cover	Cast iron with cataphoresis
4 Impeller	Stainless steel AISI 304 micro-cast
5 Motor holder	Cast iron with cataphoresis
6 Motor cover	Cast iron with cataphoresis
7 Motor shaft	Stainless steel AISI 431

8 Double mechanical seal with interposed oil chamber

Seal	Shaft	Location	Materials
STA-24	Ø 24 mm	Motor side	Ceramic / Graphite / NBR
STA-22 SIC	Ø 22 mm	Motor side	SiC / SiC / NBR

9 Electric Motor

DCm :single-phase 230 V - 50 Hz
with thermal motor protection

DC : three-phase 400 V - 50 Hz
with winding integrated thermal motor protection
to be connected to the switchboard

– Insulation: class F – Protection rating: IP X8

10 Power cord

※ 10 metres 'H07 RN-F' type

11 Float switch

12 Switch cabinet for DCM 42, DCM 43
(exclusive to single-phase models)

13 Tilting device for the float cable

(exclusive to single-ph. models) Patent No. IT0001428923

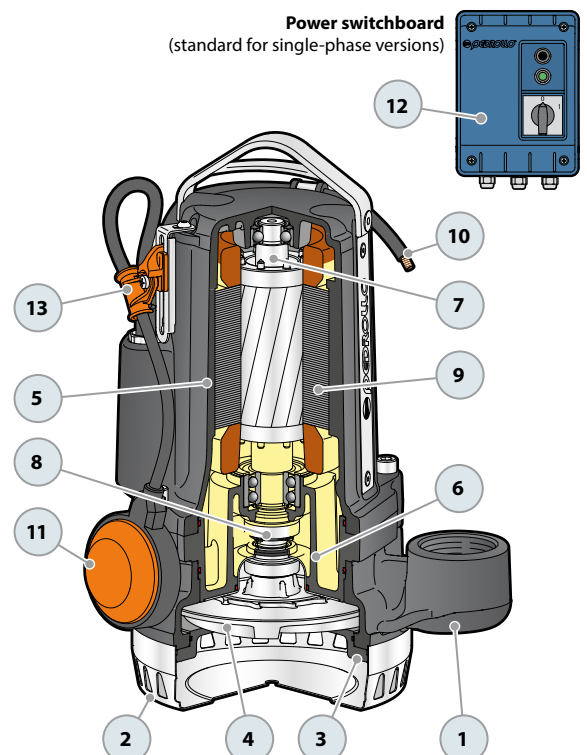



Sewage



Domestic use



INSTALLATION AND USE

The **TRITUS-TX** grinder pump is equipped with a robust, hardened **stainless steel blade**, expertly designed to cut through solids and fibers found in **domestic wastewater and sewage**. It includes a compact, integrated magnetic float switch with a vertical sliding mechanism. This innovative design ensures outmost electrical safety while facilitating operation in confined spaces, requiring as little as **220 mm** of clearance from the pit wall.

INCLUDES

- ✂ 5 m power cable
- ✂ float switch

APPLICATION LIMITS

- Depth below water level up to **5 m**
(with an appropriately sized power cable)
- Liquid temperature up to **+40 °C**
- Bottom drainage level up to **85 mm**

AVAILABLE UPON REQUEST

- ✂ Power cable length **10 m**
- ✂ Different voltage requirements 60 Hz frequency

CURVES AND PERFORMANCE DATA

50 Hz

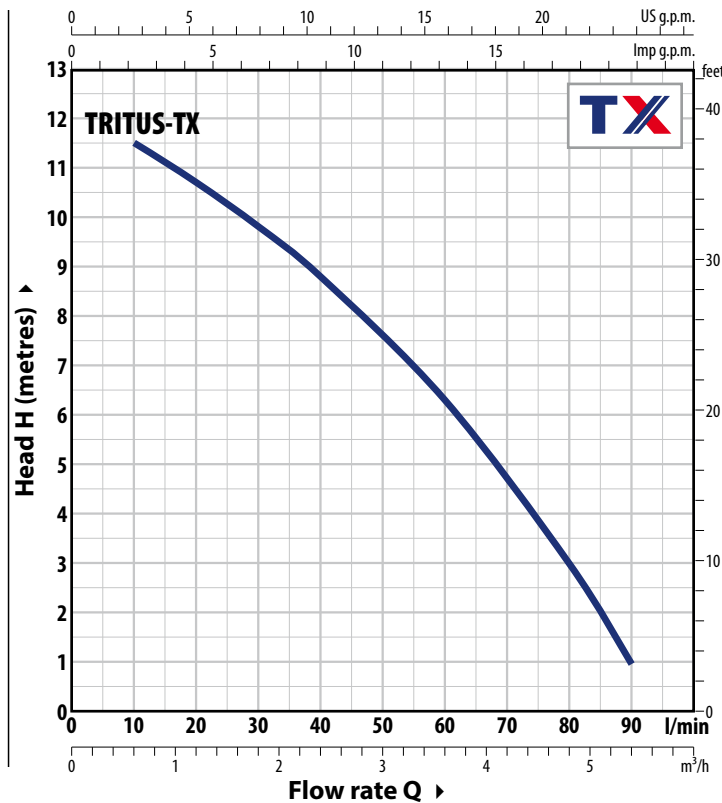

PATENTS - TRADE MARKS - MODELS

- TRITUS® Registered Trade mark No. 013017181

ABSORPTION

TYPE	VOLTAGE
Single-phase	230 V
TRITUS-TX	2.8 A

TYPE	POWER (P ₂)		Q	Flow rate									
	kW	HP		m ³ /h	l/min	0	0.6	1.2	1.8	2.4	3.6	4.8	5.4
Single-phase				0	10	20	30	40	60	80	90		
TRITUS-TX	0.55	0.75	H metres	12.0	11.5	10.5	9.6	8.6	6.2	3.0	1.0		

Q = Flow rate H = Total manometric head

Performance curves comply with EN ISO 9906 Grade 3B tolerance limits.

MATERIALS AND COMPONENTS

1 Handle	Technopolymer		
2 Pump body	Technopolymer with ISO 228/1 threaded metal insert delivery port		
3 Base	Technopolymer		
4 Conveyor belt	Technopolymer		
5 Impeller	Noryl™		
6 Grinder	Hardened AISI 440C stainless steel		
7 Motor sleeve	Stainless steel AISI 304		
8 Motor cover	Stainless steel AISI 304		
9 Motor shaft	Stainless steel AISI 431		
10 Double shaft seal with interposed oil chamber	Seal	Shaft	Materials
	STA-12R	Ø 12 mm	Ceramic / Graphite /NBR
Shaft seal	Ø 12 x Ø 19 x H 5 mm		
11 Capacitor			
12 Electric motor	single-phase 230 V - 50 Hz with winding integrated thermal motor protection Continuous duty S1, - Class F - IP X8		
13 Power cord	※ 5 metres 'H07 RN-F' type with Schuko plug		
14 Vertical solids magnetic float (adjustable)			
15 Hose connector Ø 40 mm			

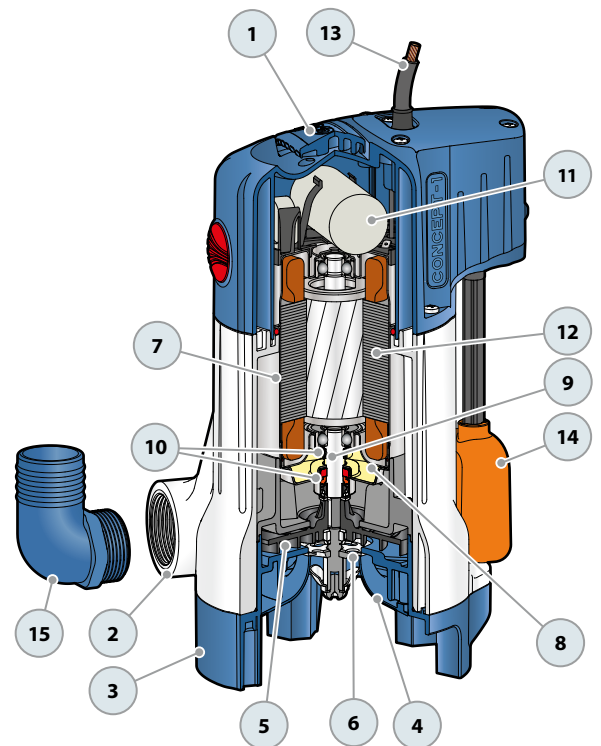

DIMENSIONS AND WEIGHT

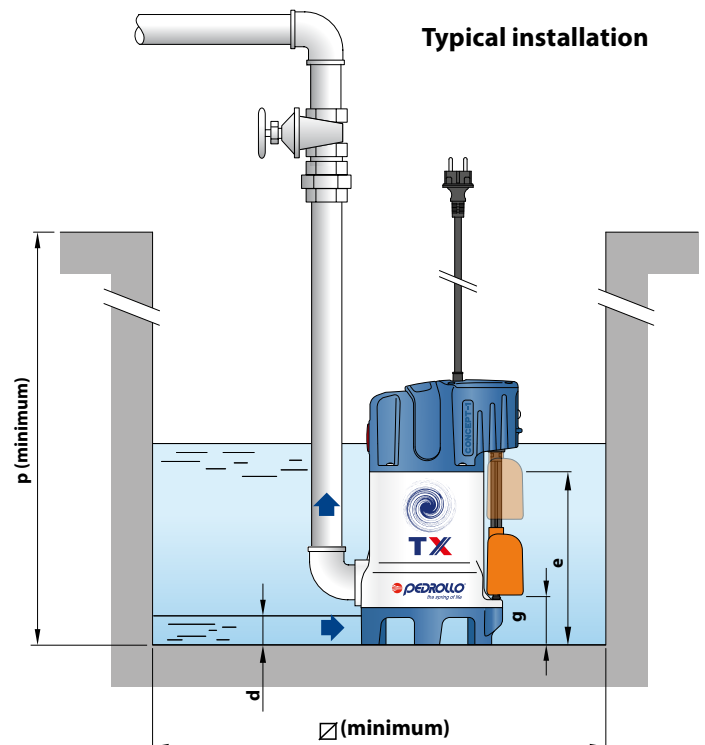
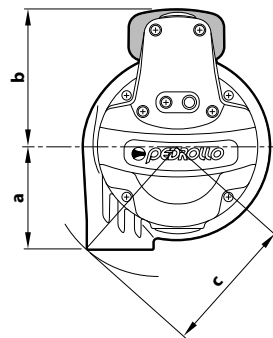
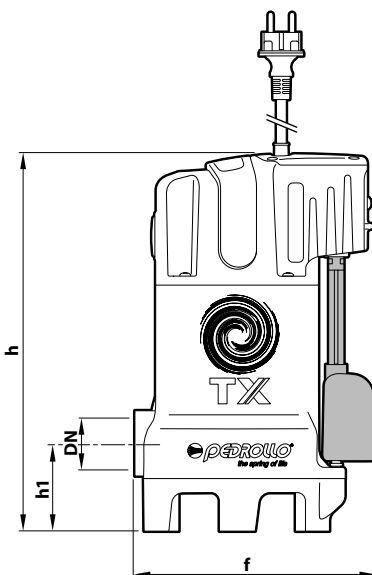

TYPE	PORT DN	DIMENSIONS mm											kg 1~	PALLET CAPACITY			
		a	b	c	f	h1	h	d	e	g (adjustable)	t	p			Ø		
Single-phase																	
TRITUS-TX	1¼"	88	117	118	205	76	324	35	100	80 or 100	251	350	220	7.0			60

-  Sewage
-  Domestic use
-  Civil use

※ TRITUS-INOX pumps deliver reliable performance in demanding work conditions



PERFORMANCE RANGE

- Flow rate up to **250 l/min** (15 m³/h)
- Head up to **24 m**

INSTALLATION AND USE

The TRITUS-INOX series is equipped with a robust, **hardened stainless steel blade**, expertly designed to cut through solids and fibers found in domestic wastewater and sewage, for pressurized transfer of materials into sewage systems via small-diameter piping

INCLUDES

- ※ Power cable length **10 m**
- ※ Float switch (exclusive to single-phase models)

APPLICATION LIMITS

- Depth below water level up to **5 m** (with an appropriately sized power cable)
- Liquid temperature up to **+40 °C**
- Bottom drainage level up to **85 mm**
- **Minimum immersion for continuous service: 300 mm**

AVAILABLE UPON REQUEST

- ※ Different voltage requirements 60 Hz frequency
- ※ Three-phase pumps
- ※ For TIGm 1.1 and TIGm 1.3 external control cabinet for increased operational safety due to special capacitor that significantly increases torque. The panel includes the manual reset motor protection switch.

PATENTS - TRADE MARKS - MODELS

- Patent No. EP2313658
- Patent No. IT0001428923
- TRITUS® Registered Trade mark No. 013017181

CURVES AND PERFORMANCE DATA

50 Hz

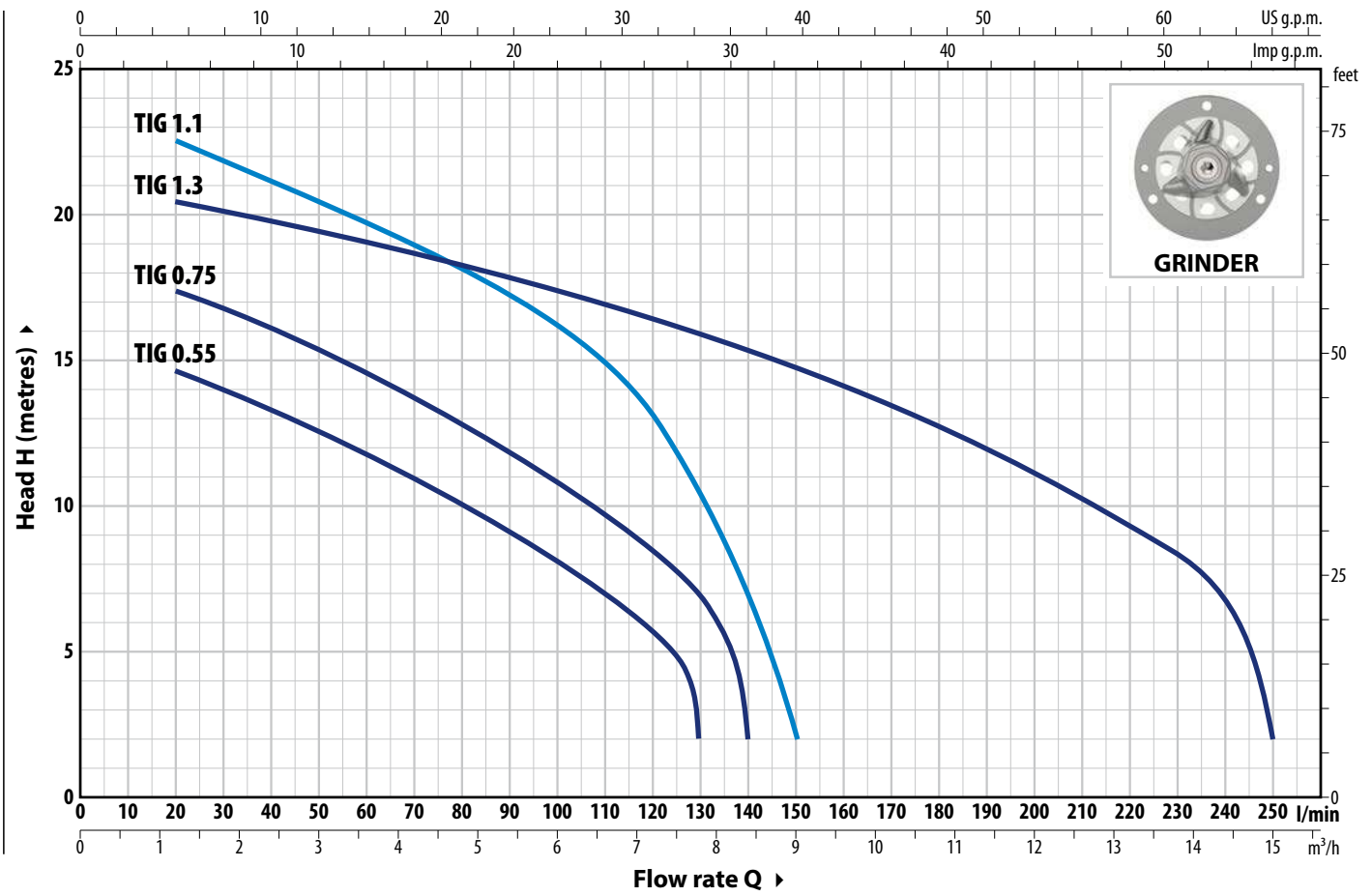

TYPE	POWER (P ₂)		Q	Flow rate																
	kW	HP		0	1.2	2.4	3.6	4.8	6	7.2	7.8	8.4	9	10.2	12	13.2	14.4	15		
Single-phase			l/min	0	20	40	60	80	100	120	130	140	150	170	200	220	240	250		
TIGm 0.55	0.55	0.75	H metres	16	14.5	13.3	11.8	10	8	5.7	2									
TIGm 0.75	0.75	1		18.5	17.5	16	14.6	12.8	10.8	14	7	2								
TIGm 1.1	1.1	1.5		24	22.5	21	19.5	18	16.3	13	10.4	6.8	2							
TIGm 1.3	1.3	1.75		21	20.5	19.7	19	18.2	17.4	16.5	16	15.4	14.8	13.5	11	9.2	7	2		

Q = Flow rate H = Total manometric head

Performance curves comply with EN ISO 9906 Grade 3B tolerance limits.

ABSORPTION

TYPE	VOLTAGE
Single-phase	230 V
TIGm 0.55	4.5 A
TIGm 0.75	5.5 A
TIGm 1.1	6.7 A
TIGm 1.3	7.0 A

DIMENSIONS AND WEIGHT

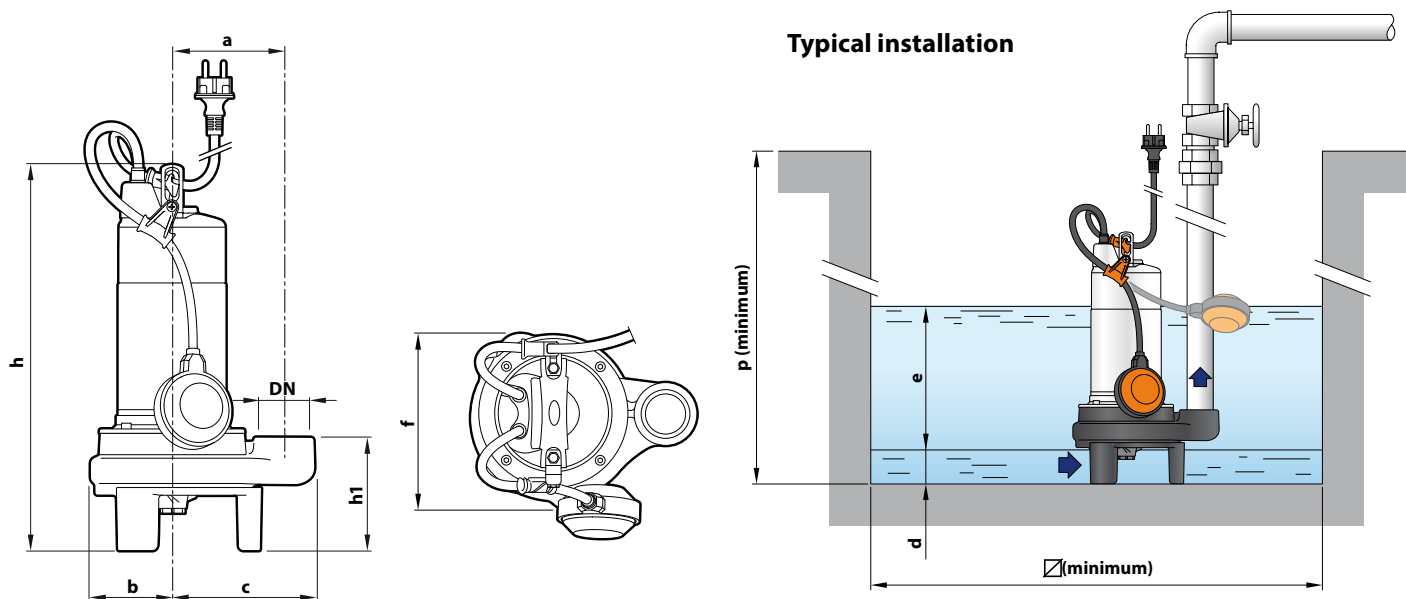

TYPE	PORT DN	DIMENSIONS mm										kg 1~
		a	b	c	f	h	h1	d	e	p	∅	
Single-phase												
TIGm 0.55	1½"	115	85	147	177	398	117	65	adjustable	500	500	15.9
TIGm 0.75												
TIGm 1.1			93	195	432	127	70					18.3
TIGm 1.3												

PALLET CAPACITY

TYPE	NO. OF PUMPS
Single-phase	
TIGm 0.55	60
TIGm 0.75	60
TIGm 1.1	45
TIGm 1.3	45

MATERIALS AND COMPONENTS

1 Pump body Cast iron with cathaphoresis treatment, provided with ISO 228/1 threaded port

2 Impeller Open type in technopolymer

3 Grinder Hardened **AISI 440C** stainless steel

4 Motor shaft Stainless steel **AISI 431**

5 Motor sleeve Stainless steel **AISI 304**

6 Double shaft seal with interposed oil chamber

Water pump	Seal	Shaft	Location	Materials
TIG 0.55	MG1-14D SIC	Ø 14 mm	Motor side	SiC / Graphite / NBR
TIG 0.75			Pump side	SiC / SiC / NBR
TIG 1.1	ST1-14 SIC	Ø 14 mm		Ceramic / SiC / NBR
TIG 1.3	Shaft seal	Ø 16 x Ø 24 x H 5 mm		

7 Electric motor

Single-phase 230 V - 50 Hz
with winding integrated thermal motor protection

- Insulation: class F
- Protection rating: IP X8

8 Power cord

※ 10 metres 'H07 RN-F' type with Schuko plug

9 Float switch

10 Tilting device for the float cable

Patent No. IT0001428923

11 Power cable strain relief

Patent No. EP2313658

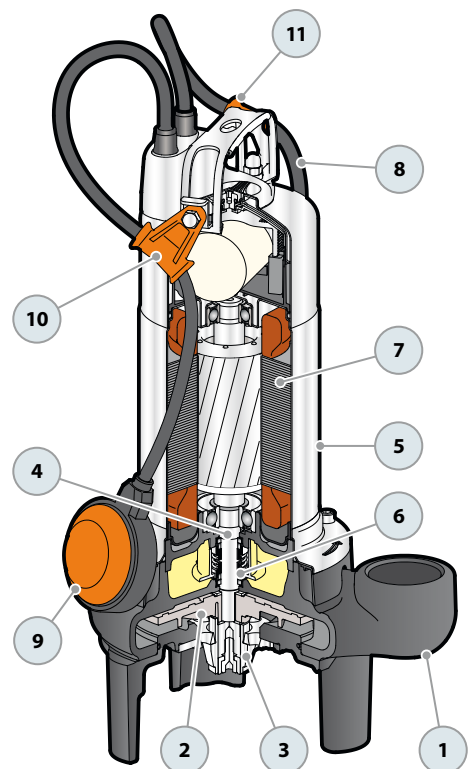



Sewage



Domestic use



Industrial use



TRm 1.3



TRm 2.2 AP

PERFORMANCE RANGE

- Flow rate up to **410 l/min** (24.6 m³/h)
- Head up to **44.5 m**

INSTALLATION AND USE

The **TRITUS** is constructed from thick cast iron, offering exceptional robustness, abrasion resistance, and longevity. The pumps are equipped with a robust, **hardened stainless steel blade**, expertly designed to cut through solids and fibers found in **domestic and civil** wastewater and sewage, for pressurized transfer of materials into sewage systems via small-diameter piping

INCLUDES

- ✘ Power cable length **10 m**
- ✘ Float switch (exclusive to single-phase models)
- ✘ Switchbox compatible with single-phase versions

APPLICATION LIMITS

- Depth below water level up to **10 m** (with an appropriately sized power cable)
- Liquid temperature up to **+40 °C**
- Draining capability from bottom up to:
 - **85 mm** for 0.75, 0.9, 1.1, 1.3
 - **95 mm** for 1.5, 2.2, TR 2.2 AP, TR 3 AP, TR 3, TR 4
- **Minimum immersion for continuous service:**
 - **300 mm** for 0.75, 0.9, 1.1, 1.3
 - **350 mm** for 1.5, 2.2, TR 2.2 AP, TR 3 AP, TR 3, TR 4

AVAILABLE UPON REQUEST

- ✘ Different voltage requirements 60 Hz frequency

WARRANTY

- ✘ **The warranty for the Three-Phase TR 1.5, TR 2.2, TR 2.2 AP, TR3 AP, TR3, TR 4 models remains valid only if the motor's built-in thermal protector is properly connected to the control panel. This connection is essential for the warranty's applicability.**

PATENTS - TRADE MARKS - MODELS

- Patent No. IT0001428923
- Registered Community Model No. 002501486-0002, 008625685-0005, 008625685-0006
- TRITUS® Registered Trade mark No. 013017181

CURVES AND PERFORMANCE DATA

50 Hz

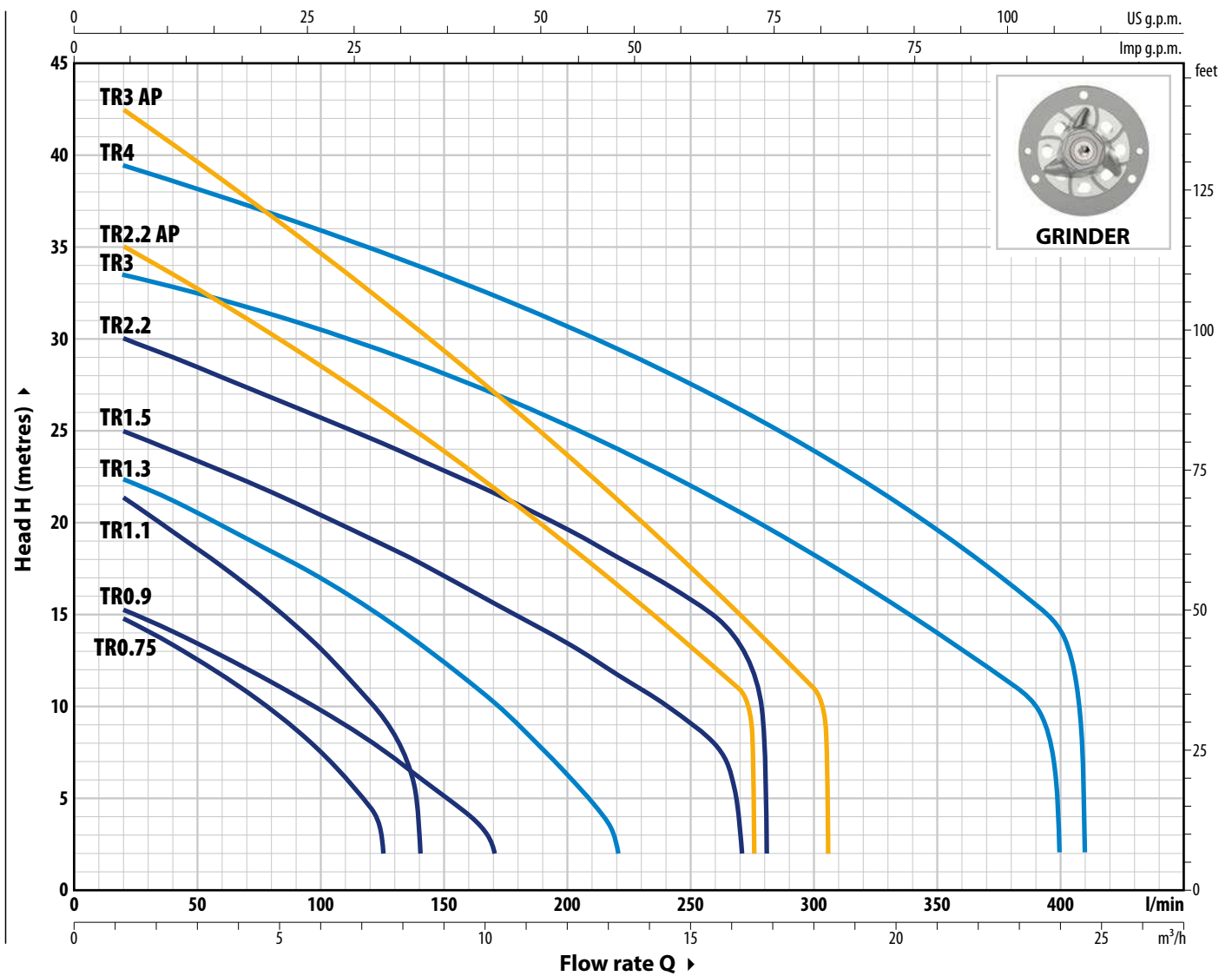

TYPE		POWER (P ₂)		Q	Flow rate															
Single-ph.	Three-ph.	kW	HP		m ³ /h	0	1.2	3	4.8	6	7.5	8.4	10.2	12	13.2	14.4	16.2	16.8		
				l/min	0	20	50	80	100	125	140	170	200	220	240	270	280			
TRm 0.75	TR 0.75	0.75	1	H metres	16.5	15	12.7	10	7.5	2										
TRm 0.9	TR 0.9	0.9	1.25		16	15	13.2	11	9.6	7.5	6	2								
TRm 1.1	TR 1.1	1.1	1.5		23	21.5	18.6	15.5	13	9.5	2									
TRm 1.3	TR 1.3	1.3	1.75		23.5	22.5	20.6	18.4	17	14.8	13.4	10.2	6.2	2						
TRm 1.5	TR 1.5	1.5	2		26	25	23.4	21.7	20.4	18.8	17.8	15.6	13.4	11.7	10	2				
-	TR 2.2	2.2	3		31	30	28.4	26.8	25.7	24.3	23.5	21.5	19.5	18	16.5	13.2	2			

TYPE		POWER (P ₂)		Q	Flow rate											
Single-ph.	Three-ph.	kW	HP		m ³ /h	0	1.2	3	6	9	12	15	16.5	18	18.3	
				l/min	0	20	50	100	150	200	250	275	300	305		
TRm 2.2 AP	TR 2.2 AP	2.2	3	H metres	36.5	35	33	28.5	23.8	18.7	13.2	2				
-	TR 3 AP	3	4		44.5	42.5	40	35	29.5	23.7	17.5	14.3	11	2		

TYPE		POWER (P ₂)		Q	Flow rate										
Three-phase		kW	HP		m ³ /h	0	1.2	3	6	9	12	15	18	21	24
				l/min	0	20	50	100	150	200	250	300	350	400	410
TR 3		3	4	H metres	34.5	33.5	32.5	30.4	28	25.2	22	18.4	14.2	2	
TR 4		4	5.5		40	39.5	38	35.7	33.3	30.6	27.4	23.8	19.4	14.3	2

Q = Flow rate H = Total manometric head

Performance curves comply with EN ISO 9906 Grade 3B tolerance limits.

ABSORPTION

TYPE	VOLTAGE
Single-phase	230 V
TRm 0.75	5.5 A
TRm 0.9	6.0 A
TRm 1.1	7.4 A
TRm 1.3	9.0 A

TYPE	VOLTAGE
Three-phase	400 V
TR 0.75	2.5 A
TR 0.9	2.6 A
TR 1.1	3.0 A
TR 1.3	3.8 A

DIMENSIONS AND WEIGHT

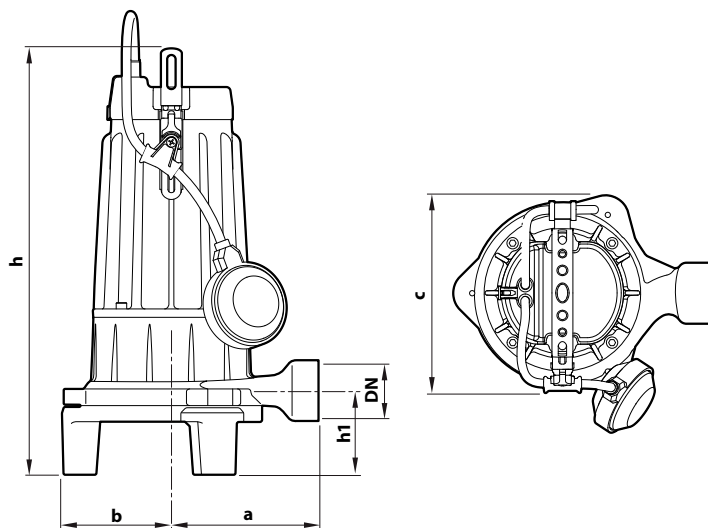

Typical installation

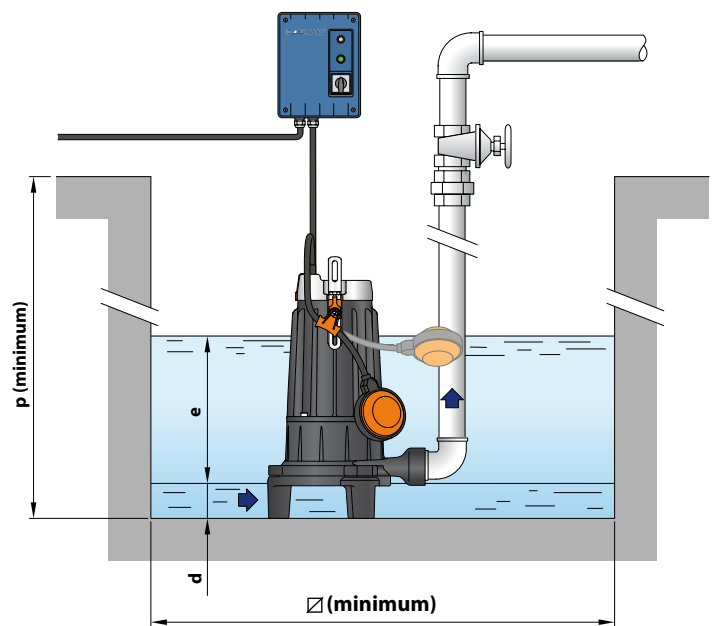

TYPE		PORT DN	DIMENSIONS mm									kg *	
Single-ph.	Three-ph.		a	b	c	h	h1	d	e	p	∅	1~	3~
TRm 0.75	TR 0.75	1 1/4"	140	104	186	406	80	85	adjustable	500	500	24.0	22.2
TRm 0.9	TR 0.9											23.9	22.2
TRm 1.1	TR 1.1											25.7	23.1
TRm 1.3	TR 1.3											25.5	23.1

(* weight of pump without control panel)

PALLET CAPACITY

TYPE	NO. OF PUMPS
Single-ph.	
TRm 0.75	36
TRm 0.9	36
TRm 1.1	36
TRm 1.3	36

TYPE	NO. OF PUMPS
Three-ph.	
TR 0.75	60
TR 0.9	60
TR 1.1	60
TR 1.3	60

MATERIALS AND COMPONENTS

1 Pump body Cast iron with cathoresis treatment

2 Impeller Open type in technopolymer

3 Grinder Hardened **AISI 440C** stainless steel

4 Motor shaft Stainless steel **AISI 431**

5 Motor holder Cast iron with cathoresis treatment

6 Double mechanical seal in oil chamber

Seal	Shaft	Location	Materials
MG1-14D SIC	Ø 14 mm	Motor side	Silicon carbide / Graphite / NBR
		Pump side	Silicon carbide/Silicon carbide/NBR

7 Electric Motor

TRm: single-phase 230 V - 50 Hz with thermal motor protection

TR: three-phase 400 V - 50Hz

- Insulation: class F
- Protection rating: IP X8

8 Power cord

※ 10 metres 'H07 RN-F' type

9 Float switch

(exclusive to single-phase models)

10 Switchboard (exclusive to single-phase models)

- Including:
- ON/OFF switch
 - manual reset motor protection
 - operating capacitor (permanently switched on)
 - starting capacitor

Power switchboard
(standard for single-phase versions)

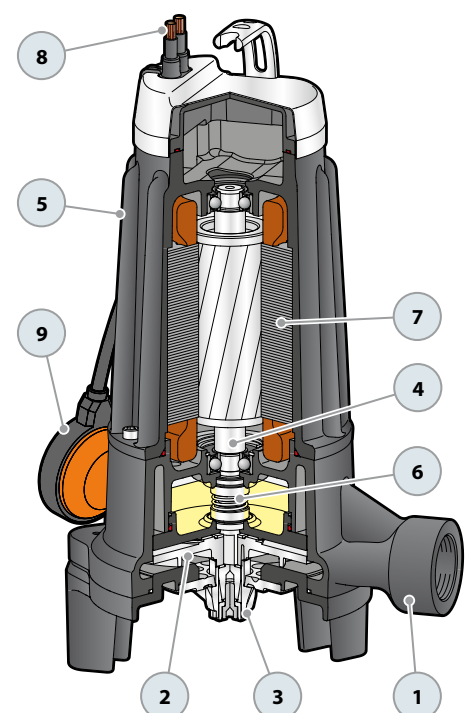
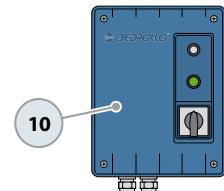

ABSORPTION

TYPE	VOLTAGE
Single-phase	230 V
TRm 1.5	10.0 A

TYPE	VOLTAGE
Three-phase	400 V
TR 1.5	3.7 A
TR 2.2	5.5 A

DIMENSIONS AND WEIGHT

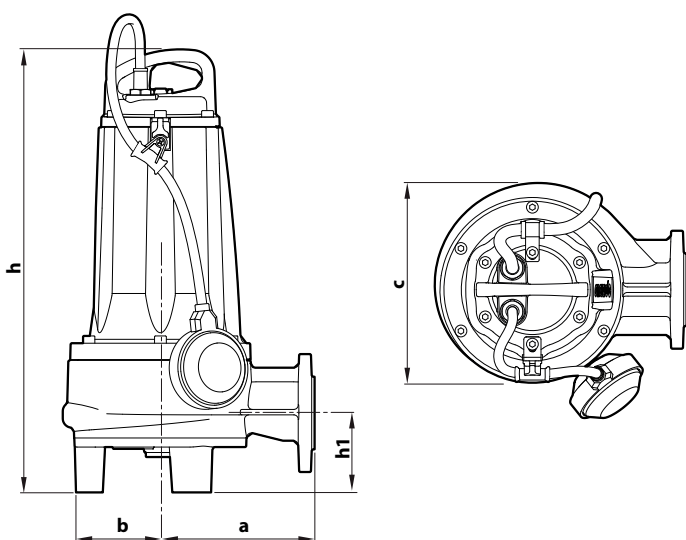

Typical installation

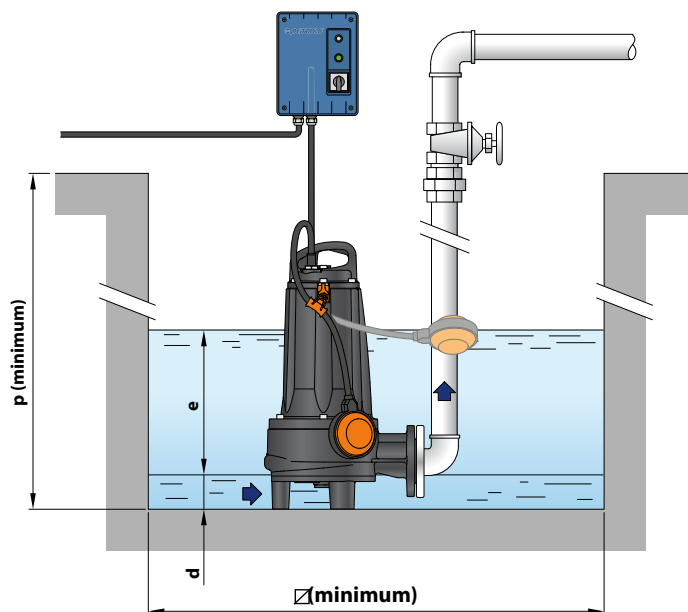

TYPE		DIMENSIONS mm									kg	
Single-phase	Three-phase	a	b	c	h	h1	d	e	p	∅	1~	3~
TRm 1.5	TR 1.5	172	105	221	489	87.5	95	adjustable	800	800	45.0	44.0
-	TR 2.2										-	44.0

PORT FLANGE

TYPE		FLANGE	F	K	D	HOLES	
Single-phase	Three-phase	DN	mm	mm	N°	∅ (mm)	
TRm 1.5	TR 1.5	40 (PN6)	1½"	100	130	4	14
-	TR 2.2						

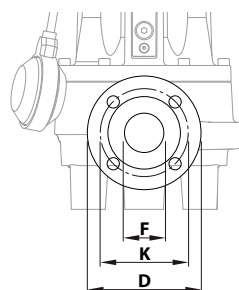

PALLET CAPACITY

TYPE		NO. OF PUMPS
Single-phase	Three-phase	
TRm 1.5	TR 1.5	12
-	TR 2.2	12

MATERIALS AND COMPONENTS

1 Pump body Cast iron with cataphoresis treatment

2 Impeller Micro-cast **AISI 304** stainless steel

3 Grinder Hardened **AISI 440C** stainless steel

4 Motor shaft Stainless steel **AISI 431**

5 Motor holder Cast iron with cataphoresis treatment

6 Double mechanical seal with interposed oil chamber

Seal	Shaft	Location	Materials
STA-20	Ø 20 mm	Motor side	Ceramic / Graphite / NBR
STA-19	Ø 19 mm	Pump side	Silicon carbide/Silicon carbide/NBR

7 Electric Motor

TRm: single-phase 230 V - 50 Hz with thermal motor protection

TR: three-phase 400 V - 50Hz

✘ with winding integrated thermal motor protection to be connected to the switchboard

- Insulation: class F
- Protection rating: IP X8

Power switchboard
(standard for single-phase versions)

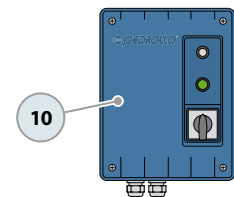

8 Power cord

✘ 10 metres 'H07 RN-F' type

9 Float switch

(exclusive to single-phase models)

10 Switchboard (exclusive to single-phase models)

- Including:
- ON/OFF switch
 - manual reset motor protection
 - operating capacitor (permanently switched on)
 - starting capacitor

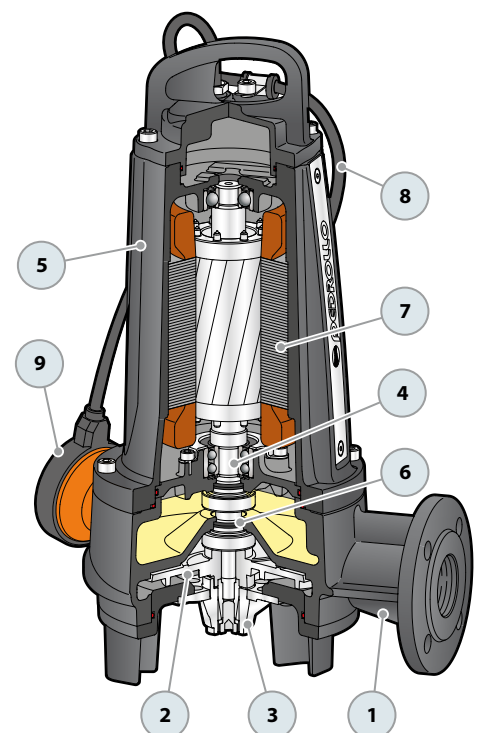

ABSORPTION

TYPE	VOLTAGE
Single-phase	230 V
TRm 2.2 AP	14.0 A

TYPE	VOLTAGE
Three-phase	400 V
TR 2.2 AP	5.5 A
TR 3 AP	6.3 A
TR 3	6.3 A
TR 4	7.5 A

DIMENSIONS AND WEIGHT

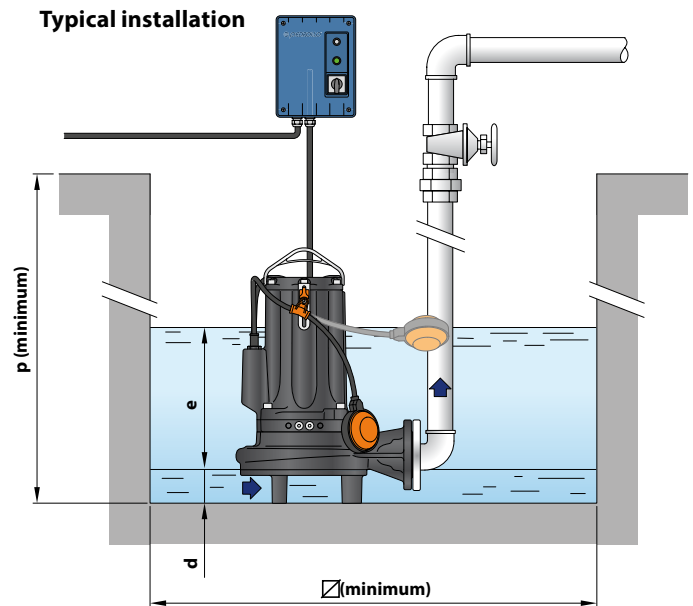
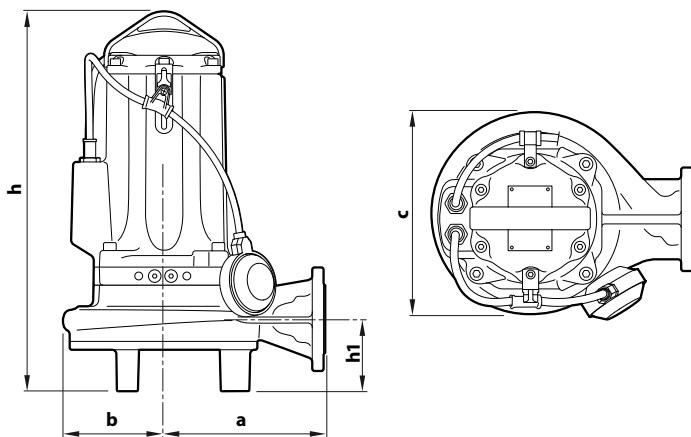

TYPE		DIMENSIONS mm									kg	
Single-phase	Three-phase	a	b	c	h	h1	d	e	p	Ø	1~	3~
TRm 2.2 AP	TR 2.2 AP	203	126	256	480 453	90	95	adjustable	800	800	53.5	47.0
-	TR 3 AP				480						-	53.0
-	TR 3				-						-	53.0
-	TR 4				-						-	54.0

PORT FLANGE

TYPE		FLANGE DN	F	K mm	D mm	L mm	HOLES	
Single-phase	Three-phase						N°	Ø mm
TRm 2.2 AP	TR 2.2 AP	40 (PN10)	1½"	110	150	130	4	18
-	TR 3 AP							
-	TR 3							
-	TR 4							

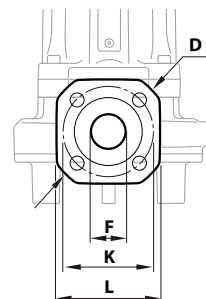

PALLET CAPACITY

TYPE		NO. OF PUMPS
Single-phase	Three-phase	
TRm 2.2 AP	TR 2.2 AP	18
-	TR 3 AP	18
-	TR 3	18
-	TR 4	18

MATERIALS AND COMPONENTS

1 Pump body	Cast iron with cathoporesis treatment
2 Impeller	Open type in micro-cast AISI 304 stainless steel
3 Grinder	Hardened AISI 440C stainless steel
4 Motor shaft	Stainless steel AISI 431
5 Motor holder	Cast iron with cathoporesis treatment
6 Motor bracket	Cast iron with cathoporesis treatment

7 Double mechanical seal with interposed oil chamber

Seal	Shaft	Location	Materials
STA-24	Ø 24 mm	Motor side	Ceramic / Graphite / NBR
STA-22 SIC	Ø 22 mm	Pump side	Silicon Carbide/Silicon Carbide/NBR

8 Electric Motor

TRm: single-phase 230 V - 50 Hz with thermal motor protection

TR: three-phase 400 V - 50Hz

✘ with winding integrated thermal motor protection to be connected to the switchboard

- Insulation: class F
- Protection rating: IP X8

Power switchboard
(standard for single-phase versions)

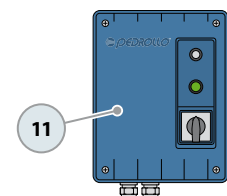

9 Power cord

✘ 10 metres 'H07 RN-F' type

10 Float switch

(exclusive to single-phase models)

11 Switchboard (exclusive to single-phase models)

Including:

- ON/OFF switch
- manual reset motor protection
- operating capacitor (permanently switched on)
- starting capacitor

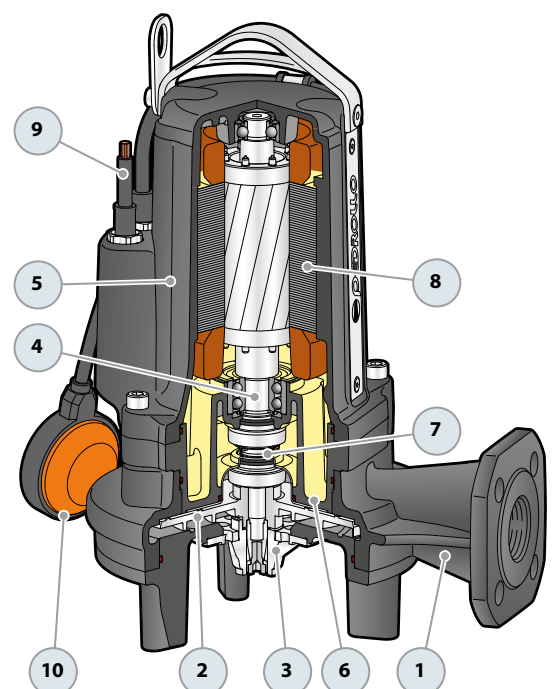

SEWAGE LIFTING SYSTEM (TRITUS 0.75 - 2.2)

VERSION WITH HORIZONTAL DELIVERY AND 3/4" GUIDE PIPES

For TR 0.75, 0.9, 1.1, 1.3	Code ASSPTRITUS11	DN 2"
For TR 1.5, 2.2	Code ASSPTRITUS22	DN 2"

※ Kit consisting of:



Coupling foot



Guide rail



Support for guide tubes



VERSION WITH VERTICAL DELIVERY AND 3/4" GUIDE PIPES

For TR 0.75, 0.9, 1.1, 1.3	Code ASSPTRITUS11V	DN 2 1/2"
For TR 1.5, 2.2	Code ASSPTRITUS22V	DN 2 1/2"

※ Kit consisting of:



Coupling foot complete with counter-flange



Guide rail



Support for guide tubes



● ACCESSORIES AVAILABLE FOR ORDER

RUNNING GUIDE

※ For TR 0.75, 0.9, 1.1, 1.3	Code ASSFL003
※ For TR 1.5, 2.2	Code ASSFL004

Complete with ring nut and gasket for 0.75, 0.9, 1.1, 1.3

Complete with screws and seals for TR 1.5, 2.2

GUIDE TUBE SUPPORT

※ For Ø 3/4 " guide tubes	Code 859SV340INTFA
---------------------------	--------------------

To ensure stability, insert a support every 2 metres along the guide tube

GUIDE TUBE (AISI 304 stainless steel)

※ 2 metres Ø 3/4" guide tube	Code 54SARTG0052F
※ 3 metres Ø 3/4" guide tube	Code 54SARTG0053F
※ 6 metres Ø 3/4" guide tube	Code 54SARTG0056F



DIMENSIONS (Version with horizontal outlet)

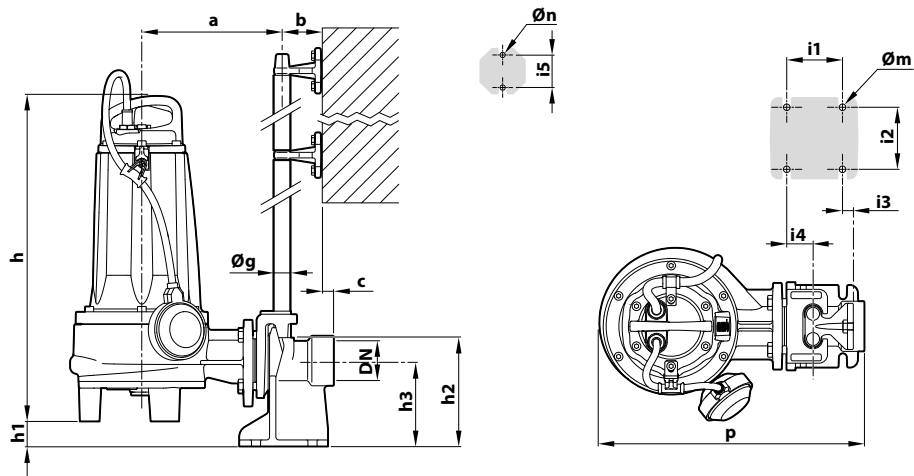

TYPE		PORT DN	Solid bodies	DIMENSIONS mm														
Single-ph.	Three-ph.			a	b	c	p	h1	h2	h3	i1	i2	i3	i4	i5	Øg	Øm	Øn
TRm 0.75	TR 0.75	2"	Ø 7 mm	212	61	17	395	50	165	130	85	94	16	40	50	¾"	14	11
TRm 0.9	TR 0.9																	
TRm 1.1	TR 1.1																	
TRm 1.3	TR 1.3																	
TRm 1.5	TR 1.5	2"	Ø 7 mm	215	61	17	400	42.5	165	130	85	94	16	40	50	¾"	14	11
-	TR 2.2																	

DIMENSIONS (Version with vertical delivery)

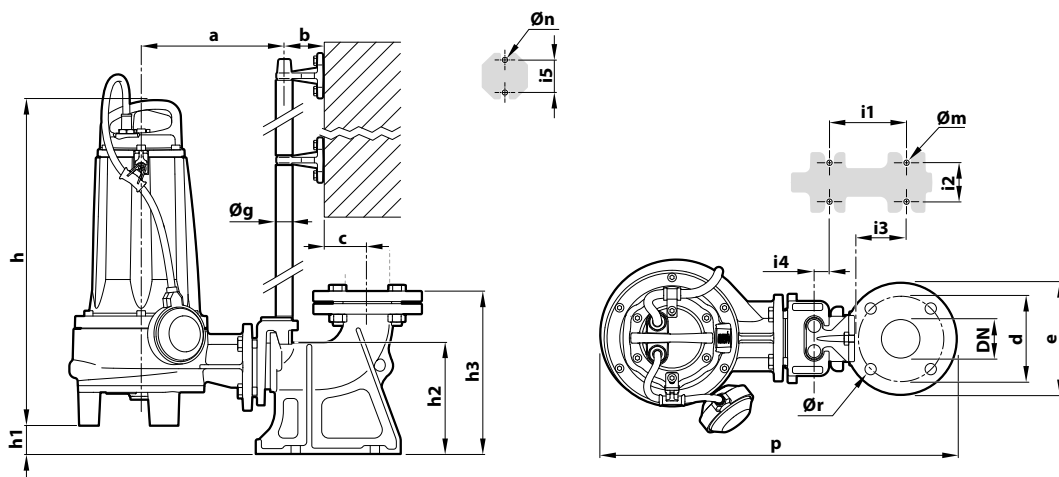

TYPE		PORT DN	Solid bodies	DIMENSIONS mm																	
Single-ph.	Three-ph.			a	b	c	d	e	p	h1	h2	h3	i1	i2	i3	i4	i5	Øg	Øm	Øn	Ør
TRm 0.75	TR 0.75	2½"	Ø 7 mm	206	61	51.5	125	165	505	48	163.5	215.5	120	72	62	3	50	¾"	14	11	18
TRm 0.9	TR 0.9																				
TRm 1.1	TR 1.1																				
TRm 1.3	TR 1.3																				
TRm 1.5	TR 1.5	2½"	Ø 7 mm	211	61	51.5	125	165	514	40	163.5	215.5	120	72	62	3	50	¾"	14	11	18
-	TR 2.2																				

SEWAGE LIFTING SYSTEM (TRITUS 2.2 AP - 3 AP - TR3 - TR4)

VERSION WITH HORIZONTAL DELIVERY AND 3/4" GUIDE PIPES

For TR 2.2 AP, 3 AP, 3, 4	Code ASSPTRITUS61	DN 2"
---------------------------	-------------------	-------

※ Kit consisting of:



Coupling foot



Guide rail



Support for guide tubes



VERSION WITH VERTICAL DELIVERY AND 3/4" GUIDE PIPES

For TR 2.2 AP, 3 AP, 3, 4	Code ASSPTRITUS61V	DN 2 1/2"
---------------------------	--------------------	-----------

※ Kit consisting of:



Coupling foot complete with counterflange



Guide rail



Support for guide tubes



● ACCESSORIES AVAILABLE FOR ORDER

RUNNING GUIDE

※ For TR 2.2 AP, 3 AP, 3, 4	Code ASSFL014
-----------------------------	---------------

Complete with screws and seals

GUIDE TUBE SUPPORT

※ For Ø 3/4 " guide tubes	Code 859SV340INTFA
---------------------------	--------------------

To ensure stability, insert a support every 2 metres along the guide tube

GUIDE TUBE (AISI 304 stainless steel)

※ 2 metres Ø 3/4" guide tube	Code 54SARTG0052F
※ 3 metres Ø 3/4" guide tube	Code 54SARTG0053F
※ 6 metres Ø 3/4" guide tube	Code 54SARTG0056F



DIMENSIONS (Version with horizontal outlet)

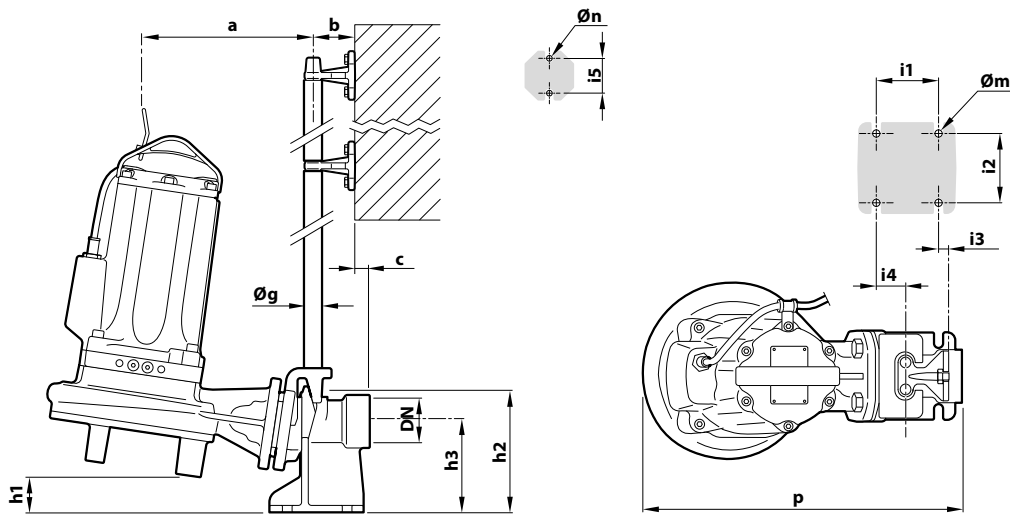

TYPE	PORT DN	Solid bodies	DIMENSIONS mm															
			a	b	c	p	h1	h2	h3	i1	i2	i3	i4	i5	Øg	Øm	Øn	
TR 2.2 AP	2"	Ø 7 mm	228	61	17	455	71	165	130	85	94	16	40	50	3/4	14	11	
TR 3 AP																		
TR 3																		
TR 4																		

DIMENSIONS (Version with vertical delivery)

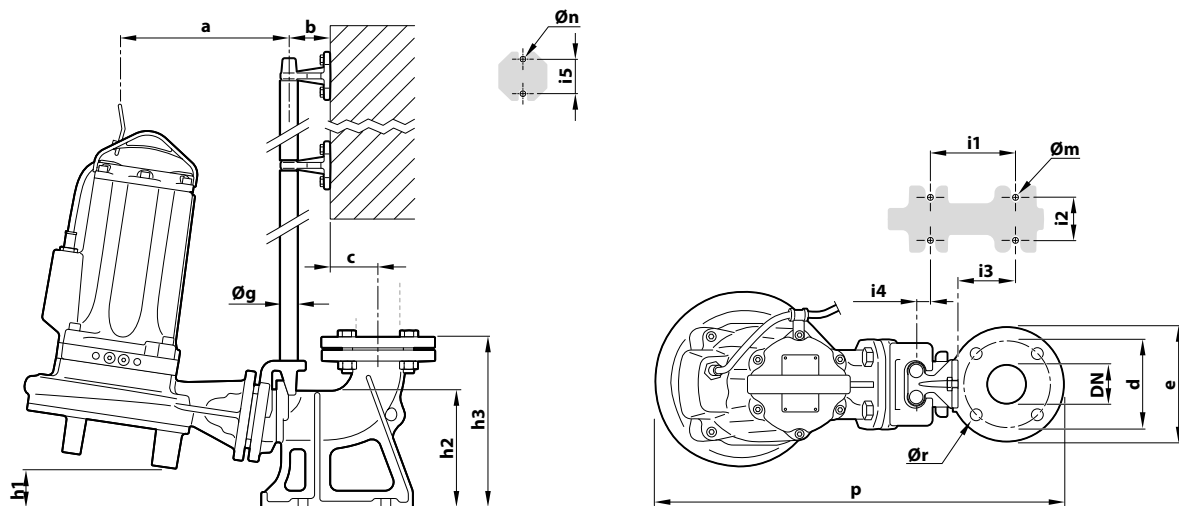

TYPE	PORT DN	Solid bodies	DIMENSIONS mm																	
			a	b	c	d	e	p	h1	h2	h3	i1	i2	i3	i4	i5	Øg	Øm	Øn	Ør
TR 2.2 AP	2½"	Ø 7 mm	225	61	51.5	125	165	569	69	163.5	215.5	120	72	62	3	50	3/4	14	11	18
TR 3 AP																				
TR 3																				
TR 4																				



Sewage



Civil use



Industrial use

※ **High-quality materials and robust construction ensure superior performance and reliability**



PERFORMANCE RANGE

- Flow rate up to **1250 l/min** (75 m³/h)
- Head up to **20 m**

INSTALLATION AND USE

The **VXC** series is constructed from thick cast iron, offering exceptional robustness, abrasion resistance, and longevity. Featuring **VORTEX**-type impellers, these pumps are designed to drain **sewage, wastewater, sludge-mixed water, activated and putrid sludge**.

They are suitable for a wide range of applications, including sewers, tunnels, excavations, canals, and underground parking facilities

APPLICATION LIMITS

- Depth below water level up to **10 m** (with an appropriately sized power cable)
- Liquid temperature up to **+40 °C**
- Suspended solids transfer:
 - up to **Ø 50 mm** for VXC /50
 - up to **Ø 65 mm** for VXC /65
- **Continuous operation of the pump even when completely uncovered.**

INCLUDES

- ※ Power cable length **10 m**
- ※ Float switch (exclusive to single-phase models)
- ※ Switchbox compatible with single-phase versions

AVAILABLE UPON REQUEST

- ※ **QES** control panel for three-phase pumps
- ※ Different voltage requirements 60 Hz frequency

WARRANTY

- ※ **The warranty for three-phase models remains valid only if the motor's built-in thermal protector is properly connected to the control panel. This connection is essential for the warranty's applicability.**

PATENTS - TRADE MARKS - MODELS

- Patent No. IT0001428923
- Registered Community Model No. 008625685-0001, No. 008625685-0002

CURVES AND PERFORMANCE DATA

50 Hz

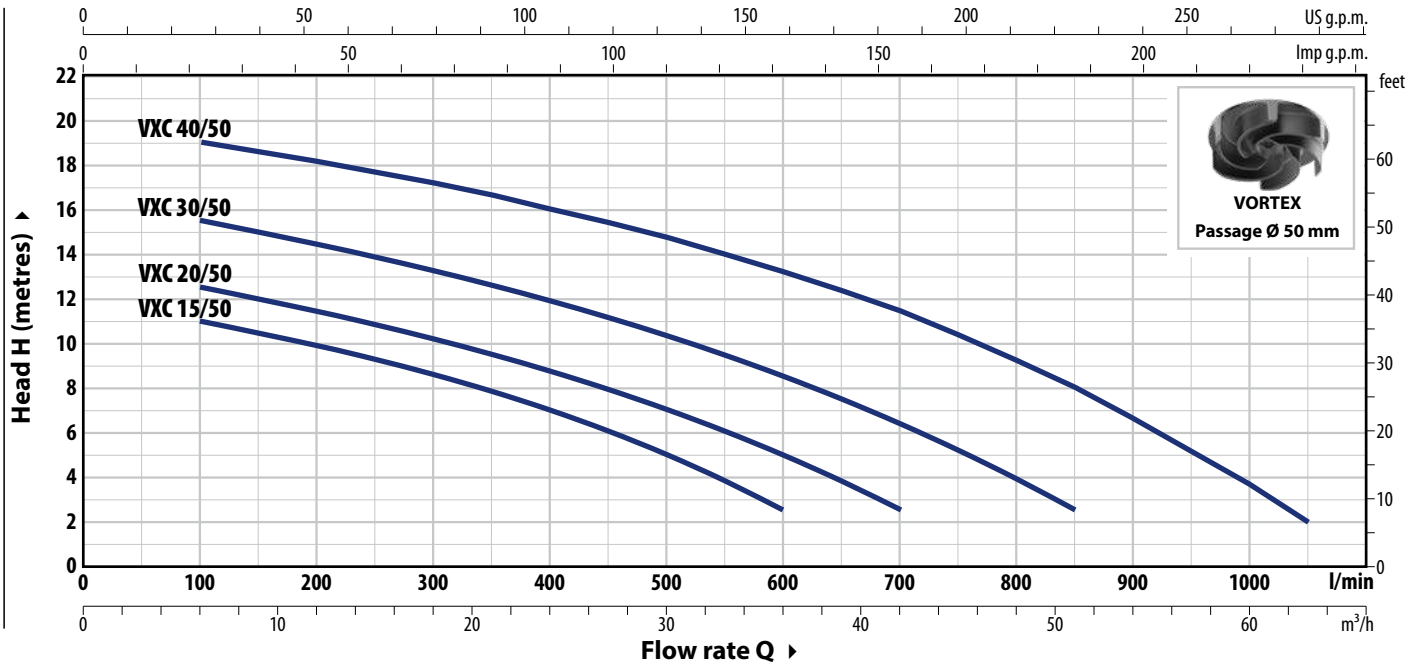

TYPE		POWER (P ₂)		Q	m ³ /h													
Single-ph.	Three-ph.	kW	HP		0	6	12	18	24	30	36	42	51	60	63			
VXCm 15/50	VXC 15/50	1.1	1.5	H metres	0	100	200	300	400	500	600	700	850	1000	1050			
VXCm 20/50	VXC 20/50	1.5	2		12	11	9.9	8.6	7	5	2.5							
VXCm 30/50	VXC 30/50	2.2	3		13.5	12.5	11.4	10.2	8.7	7	5	2.5						
-	VXC 40/50	3	4		16.5	15.5	14.4	13.2	11.9	10.3	8.5	6.4	2.5					
					20	19	18.1	17.1	16	14.7	13.2	11.4	8	3.6	2			

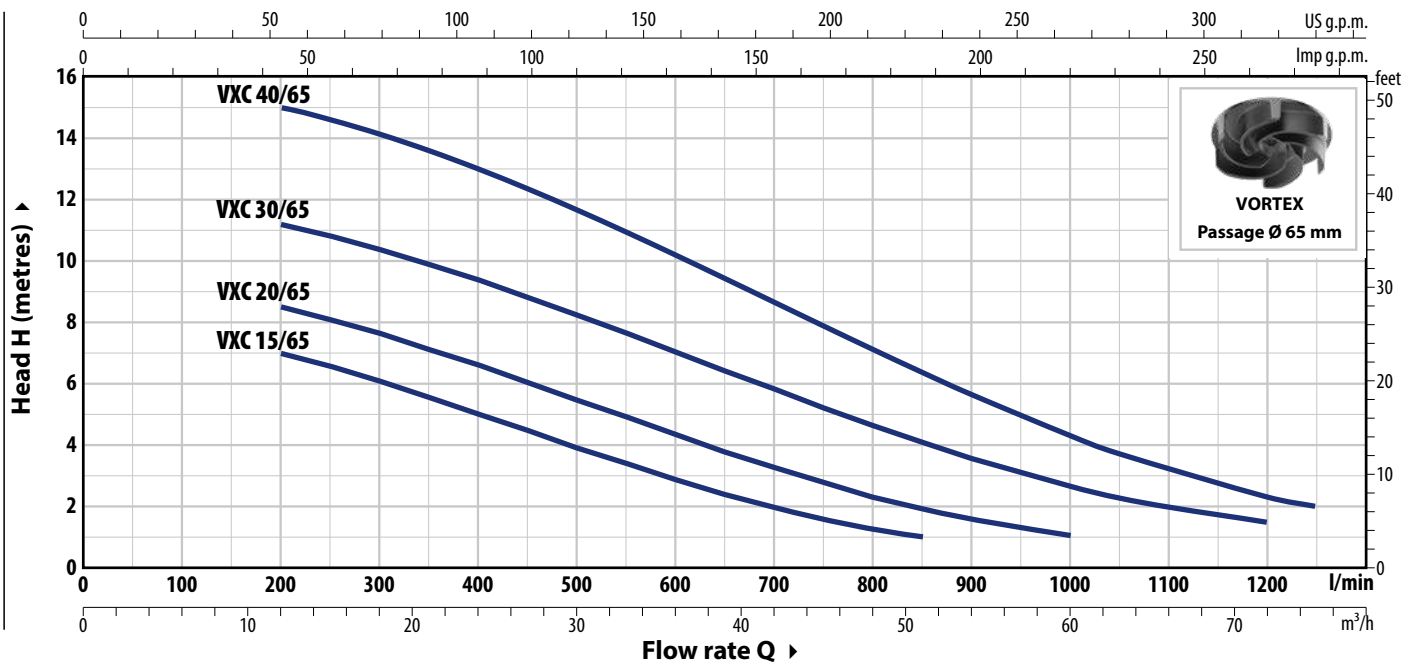

TYPE		POWER (P ₂)		Q	m ³ /h													
Single-ph.	Three-ph.	kW	HP		0	12	18	24	30	36	42	51	60	63	72	75		
VXCm 15/65	VXC 15/65	1.1	1.5	H metres	0	200	300	400	500	600	700	850	1000	1050	1200	1250		
VXCm 20/65	VXC 20/65	1.5	2		8	7	6	5	4	2.8	2	1						
VXCm 30/65	VXC 30/65	2.2	3		9.5	8.5	7.6	6.6	5.4	4.3	3.3	2	1					
-	VXC 40/65	3	4		12	11	10.3	9.3	8.2	7	5.8	4	2.6	2.3	1.5			
					15.5	15	14	13	11.6	10	8.6	6.3	4.3	3.7	2.3	2		

Q = Flow rate H = Total manometric head

Performance curves comply with EN ISO 9906 Grade 3B tolerance limits.

ABSORPTION

TYPE	VOLTAGE
Single-phase	230 V
VXCm 15/50	8.5 A
VXCm 20/50	9.0 A
VXCm 30/50	12.0 A
VXCm 15/65	8.5 A
VXCm 20/65	9.0 A
VXCm 30/65	12.0 A

TYPE	VOLTAGE
Three-phase	400 V
VXC 15/50	3.4 A
VXC 20/50	3.7 A
VXC 30/50	5.0 A
VXC 40/50	6.2 A
VXC 15/65	3.4 A
VXC 20/65	3.7 A
VXC 30/65	5.0 A
VXC 40/65	6.2 A

DIMENSIONS AND WEIGHT

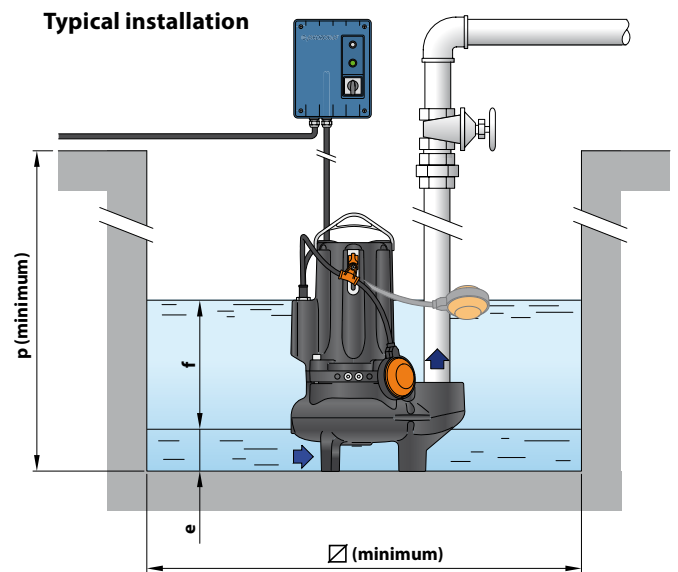
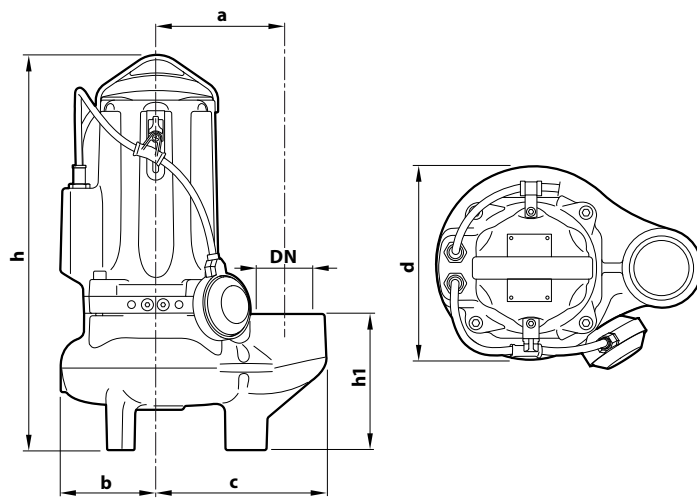

TYPE		PORT DN	Passage of solid bodies	DIMENSIONS mm											kg	
Single-phase	Three-phase			a	b	c	h	h1	d	e	f	p	∅	1~	3~	
VXCm 15/50	VXC 15/50	2½"	50 mm	162	119	212	487	167	242	75	adjustable	800	800	42.1	40.0	
VXCm 20/50	VXC 20/50						513 487							43.0	42.0	
VXCm 30/50	VXC 30/50						513							48.0	44.0	
-	VXC 40/50						513							-	48.0	
VXCm 15/65	VXC 15/65	3"	65 mm	180	120	240	521	201	246	85	adjustable	800	800	44.0	42.5	
VXCm 20/65	VXC 20/65						547 521							45.1	44.0	
VXCm 30/65	VXC 30/65						547							49.8	46.0	
-	VXC 40/65						547							-	49.8	

PALLET CAPACITY

TYPE		NO. OF PUMPS
Single-phase	Three-phase	
VXCm 15/50	VXC 15/50	16
VXCm 20/50	VXC 20/50	16
VXCm 30/50	VXC 30/50	12 16
-	VXC 40/50	12
VXCm 15/65	VXC 15/65	12
VXCm 20/65	VXC 20/65	12
VXCm 30/65	VXC 30/65	12
-	VXC 40/65	12

MATERIALS AND COMPONENTS

1 Pump body	Cast iron with cataphoresis treatment		
2 Impeller	Cast iron VORTEX type with cataphoresis treatment		
3 Motor holder	Cast iron with cataphoresis treatment		
4 Motor bracket	Cast iron with cataphoresis treatment		
5 Motor shaft	Stainless steel AISI 431		
6 Double mechanical seal with interposed oil chamber			
Seal	Shaft	Location	Materials
STA-22	Ø 22 mm	Motor side	Ceramic / Graphite / NBR
STA-20	Ø 20 mm	Pump side	Silicon carbide/Silicon carbide/NBR

7 Electric Motor

VXCm: single-phase 230 V - 50 Hz with thermal motor protection

VXC: three-phase 400 V - 50 Hz

✘ with winding integrated thermal motor protection (to be connected to the switchboard supplied on request)

- Insulation: class F
- Protection rating: IP X8

8 Power cord

✘ 10 metres 'H07 RN-F' type

9 Switchboard

(exclusive to single-phase models)

With capacitor and manual reset motor protection switch

10 Float switch

(exclusive to single-phase models)

Power switchboard
(standard for single-phase versions)

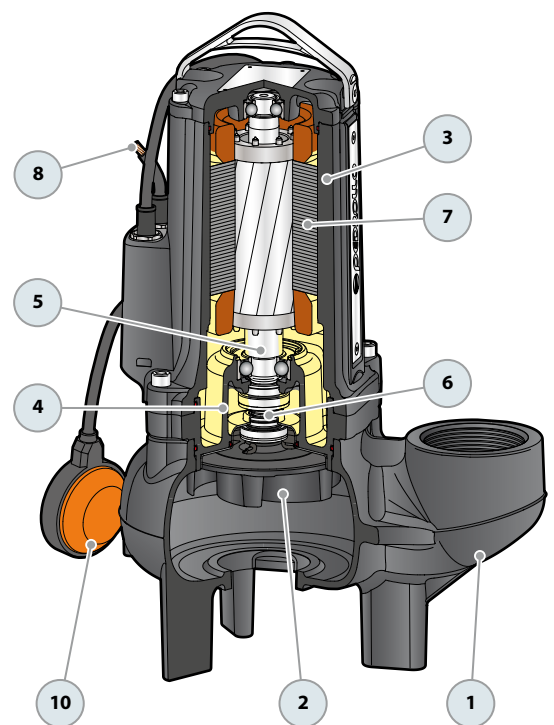
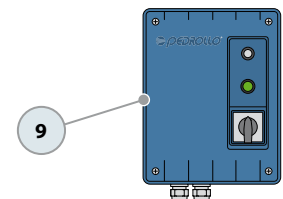

OPTIONAL - Support base
(Cod. ASSBAVM)





Sewage



Civil use



Industrial use

※ **High-quality materials and robust construction ensure superior performance and reliability**



PERFORMANCE RANGE

- Flow rate up to **1600 l/min** (96 m³/h)
- Head up to **25 m**

INSTALLATION AND USE

The **MC** series is constructed from thick cast iron, offering exceptional robustness, abrasion resistance, and longevity. Featuring **TWO-CHANNEL** impellers, these pumps are designed to drain liquids containing suspended solids and short fibers, as well as **sewage, wastewater, sludge-mixed water, activated and putrid sludge**.

They are suitable for a wide range of applications, including sewers, tunnels, excavations, canals, and underground parking facilities

APPLICATION LIMITS

- Depth below water level up to **10 m**
(with an appropriately sized power cable)
- Liquid temperature up to **+40 °C**
- Suspended solids transfer:
 - up to **Ø 50 mm** for MC /50
 - up to **Ø 65 mm** for MC /65
- **Minimum immersion for continuous service:**
 - **320 mm** for MC /50
 - **360 mm** for MC /65

INCLUDES

- ※ Power cable length **10 m**
- ※ Float switch (exclusive to single-phase models)
- ※ Switchbox compatible with single-phase versions

AVAILABLE UPON REQUEST

- ※ **QES** control panel for three-phase pumps
- ※ Different voltage requirements 60 Hz frequency

WARRANTY

- ※ **The warranty for three-phase models remains valid only if the motor's built-in thermal protector is properly connected to the control panel. This connection is essential for the warranty's applicability.**

PATENTS - TRADE MARKS - MODELS

- Patent No. IT0001428923
- Registered Community Model No. 008625685-0001, No. 008625685-0002

CURVES AND PERFORMANCE DATA

50 Hz

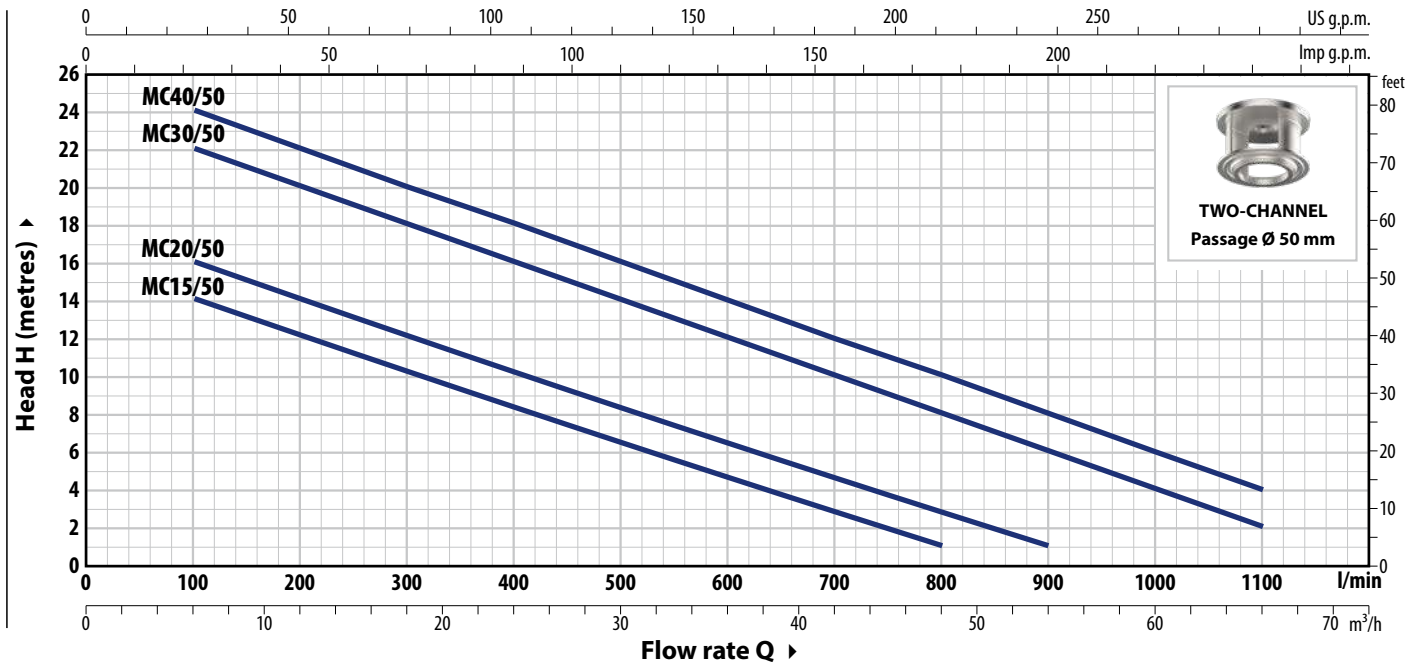

TYPE		POWER (P ₂)		Q	Flow rate															
Single-ph.	Three-ph.	kW	HP		m ³ /h	0	6	12	18	24	30	36	42	48	54	60	66			
MCm 15/50	MC 15/50	1.1	1.5	H metres	0	100	200	300	400	500	600	700	800	900	1000	1100				
MCm 20/50	MC 20/50	1.5	2		16	14	12.5	10.5	8.5	6.5	4.5	3	1							
MCm 30/50	MC 30/50	2.2	3		18	16	14	12.5	10.5	8.5	6.5	5	3	1						
-	MC 40/50	3	4		24	22	20	18	16	14	12	10	8	6	4	2				
					25	24	22	20	18	16	14	12	10	8	6	4				

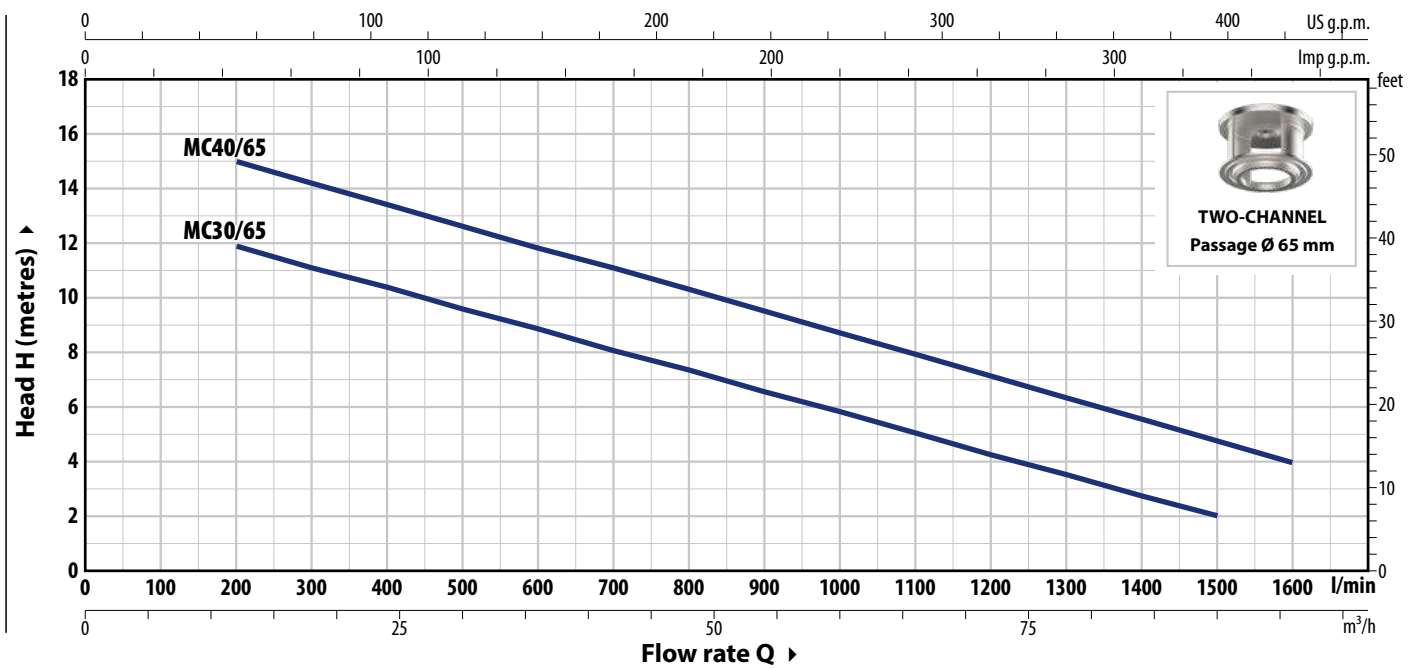

TYPE		POWER (P ₂)		Q	Flow rate															
Single-ph.	Three-ph.	kW	HP		m ³ /h	0	12	24	36	48	54	60	66	72	90	96				
MCm 30/65	MC 30/65	2.2	3	H metres	0	200	400	600	800	900	1000	1100	1200	1500	1600					
-	MC 40/65	3	4		13	12	10.5	9	7.5	6.5	6	5	4.5	2						
					17	15	13.5	12	10.5	9.5	8.5	8	7	4.8	4					

Q = Flow rate H = Total manometric head

Performance curves comply with EN ISO 9906 Grade 3B tolerance limits.

ABSORPTION

TYPE	VOLTAGE
Single-phase	230 V
MCm 15/50	10.5 A
MCm 20/50	14.0 A
MCm 30/50	18.0 A
MCm 30/65	14.0 A

TYPE	VOLTAGE
Three-phase	400 V
MC 15/50	4.5 A
MC 20/50	5.0 A
MC 30/50	6.5 A
MC 40/50	7.0 A
MC 30/65	6.5 A
MC 40/65	7.5 A

DIMENSIONS AND WEIGHT

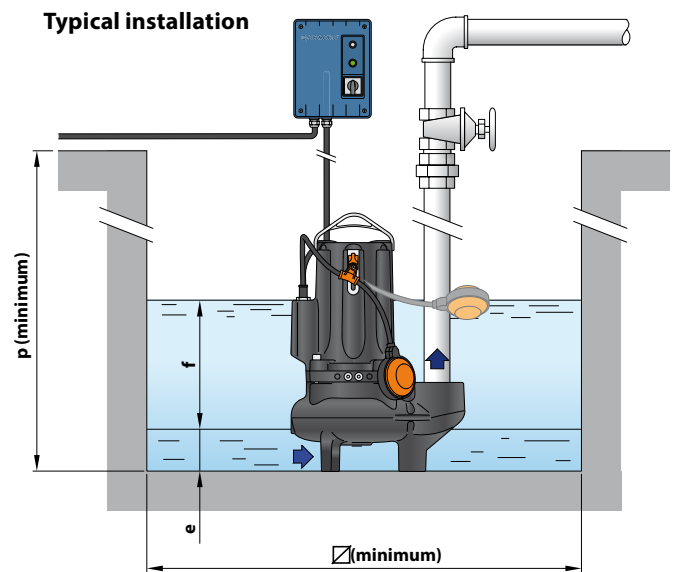
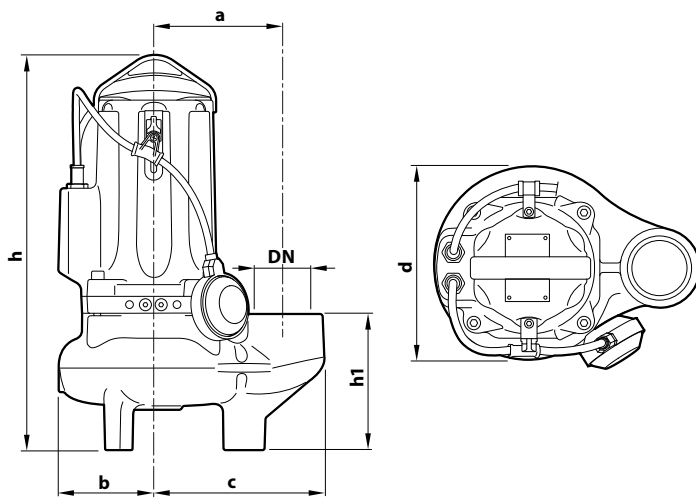

TYPE		PORT DN	Passage of solid bodies	DIMENSIONS mm										kg	
Single-phase	Three-phase			a	b	c	h	h1	d	e	f	p	Ø	1~	3~
MCm 15/50	MC 15/50	2½"	50 mm	162	119	212	487	167	242	75	adjustable	800	800	42.0	40.0
MCm 20/50	MC 20/50						513 487							43.0	41.9
MCm 30/50	MC 30/50						513							47.8	44.0
-	MC 40/50						513							-	47.8
MCm 30/65	MC 30/65	3"	65 mm	180	120	240	547 521	201	246	85	adjustable	800	800	50.0	46.0
-	MC 40/65						547							-	49.8
-	MC 40/65						547							-	49.8

PALLET CAPACITY

TYPE		NO. OF PUMPS
Single-phase	Three-phase	
MCm 15/50	MC 15/50	16
MCm 20/50	MC 20/50	16
MCm 30/50	MC 30/50	12 16
-	MC 40/50	12
MCm 30/65	MC 30/65	12
-	MC 40/65	12

MATERIALS AND COMPONENTS

1 Pump body	Cast iron with cataphoresis treatment		
2 Impeller	TWO-CHANNEL type in micro-cast AISI 304 stainless steel		
3 Motor holder	Cast iron with cataphoresis treatment		
4 Motor bracket	Cast iron with cataphoresis treatment		
5 Motor shaft	Stainless steel AISI 431		
6 Double mechanical seal with interposed oil chamber	Seal	Shaft	Location
	STA-22	Ø 22 mm	Motor side
	STA-20	Ø 20 mm	Pump side
			Materials
			Ceramic / Graphite / NBR
			Silicon carbide/Silicon carbide/NBR

7 Electric Motor

MCm: single-phase 230 V - 50 Hz with thermal motor protection

MC: three-phase 400 V - 50 Hz

✘ with winding integrated thermal motor protection (to be connected to the switchboard supplied on request)

- Insulation: class F
- Protection rating: IP X8

Power switchboard
(standard for single-phase versions)

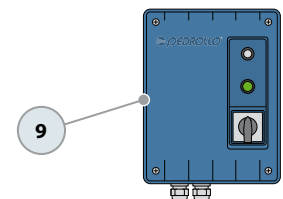

8 Power cord

✘ 10 metres 'H07 RN-F' type

9 Switchbox compatible with MCm 15-20-30 (exclusive to single-phase models)

With capacitor and manual reset motor protection switch

10 Float switch (exclusive to single-phase models)

(exclusive to single-phase models)

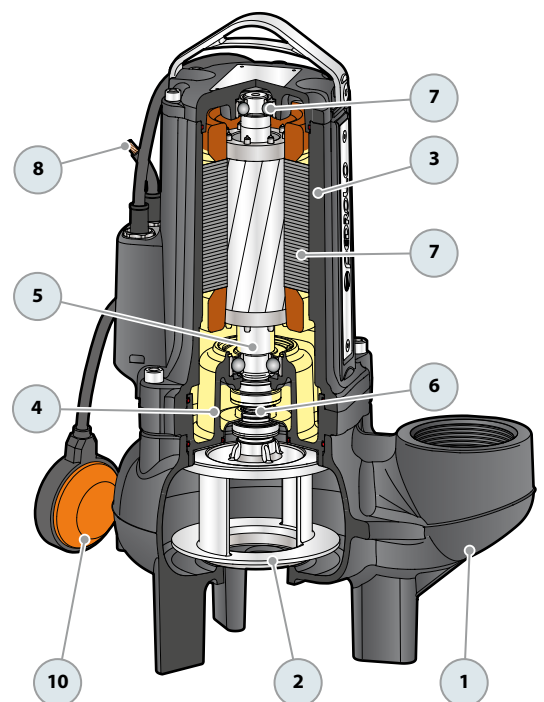

OPTIONAL - Support base
(Cod. ASSBAVM)





Sewage



Civil use



Industrial use

※ **High quality materials and robustness assure superior performance and reliability**



PERFORMANCE RANGE

- Flow rate up to **1250 l/min** (75 m³/h)
- Head up to **20 m**

INSTALLATION AND USE

The **VXC-F** series is constructed from thick cast iron, offering exceptional robustness, abrasion resistance, and longevity.

Featuring VORTEX-type impellers, these pumps are designed to drain **wastewater, sludge-mixed water, liquids with air or gas, as well as activated and putrid sludge.**

Recommended for stationary installation in sewers, tunnels, shafts, underground parking facilities, and specialized manholes.

APPLICATION LIMITS

- Depth below water level up to **10 m** (with an appropriately sized power cable)
- Liquid temperature up to **+40 °C**
- Suspended solids transfer:
 - up to **Ø 50 mm** for **VXC /50-F**
 - up to **Ø 65 mm** for **VXC /65-F**
- **Continuous operation of the pump even when completely uncovered.**

INCLUDES

- ※ Power cable length **10 m**
- ※ Float switch (exclusive to single-phase models)
- ※ Switchbox compatible with single-phase versions

AVAILABLE UPON REQUEST

- ※ Coupling foot kit
- ※ **QES** control panel for three-phase pumps
- ※ Different voltage requirements 60 Hz frequency

WARRANTY

- ※ **The warranty for three-phase models remains valid only if the motor's built-in thermal protector is properly connected to the control panel. This connection is essential for the warranty's applicability.**

PATENTS - TRADE MARKS - MODELS

- Patent No. IT0001428923

CURVES AND PERFORMANCE DATA

50 Hz

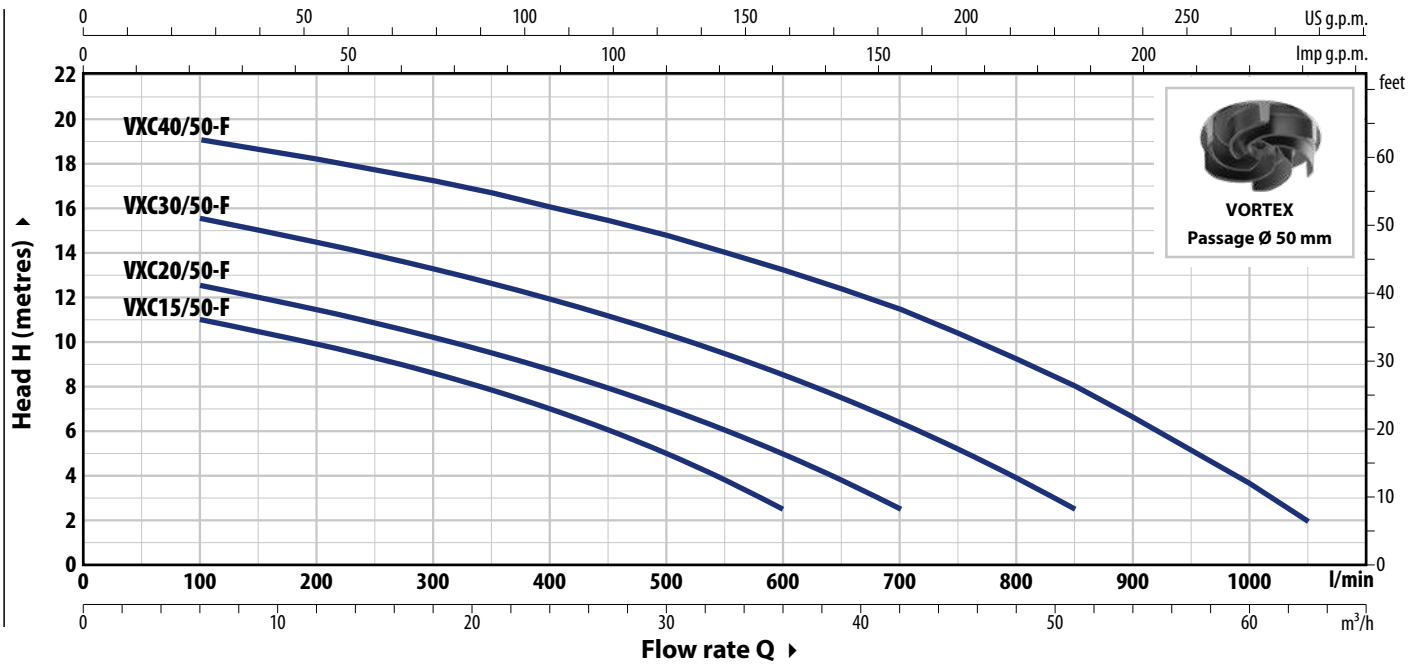

TYPE		POWER (P ₂)		Q	Flow rate												
Single-phase	Three-phase	kW	HP		m ³ /h	0	6	12	18	24	30	36	42	51	60	63	
VXCm 15/50-F	VXC 15/50-F	1.1	1.5	H metres	0	100	200	300	400	500	600	700	850	1000	1050		
VXCm 20/50-F	VXC 20/50-F	1.5	2		12	11	10	8.6	7	5	2.5						
VXCm 30/50-F	VXC 30/50-F	2.2	3		13.5	12.5	11.4	10.2	8.7	7	5	2.5					
-	VXC 40/50-F	3	4		16.5	15.5	14.4	13.2	12	10.3	8.5	6.4	2.5				
					20	19	18	17	16	14.7	13.2	11.4	8	3.6	2		

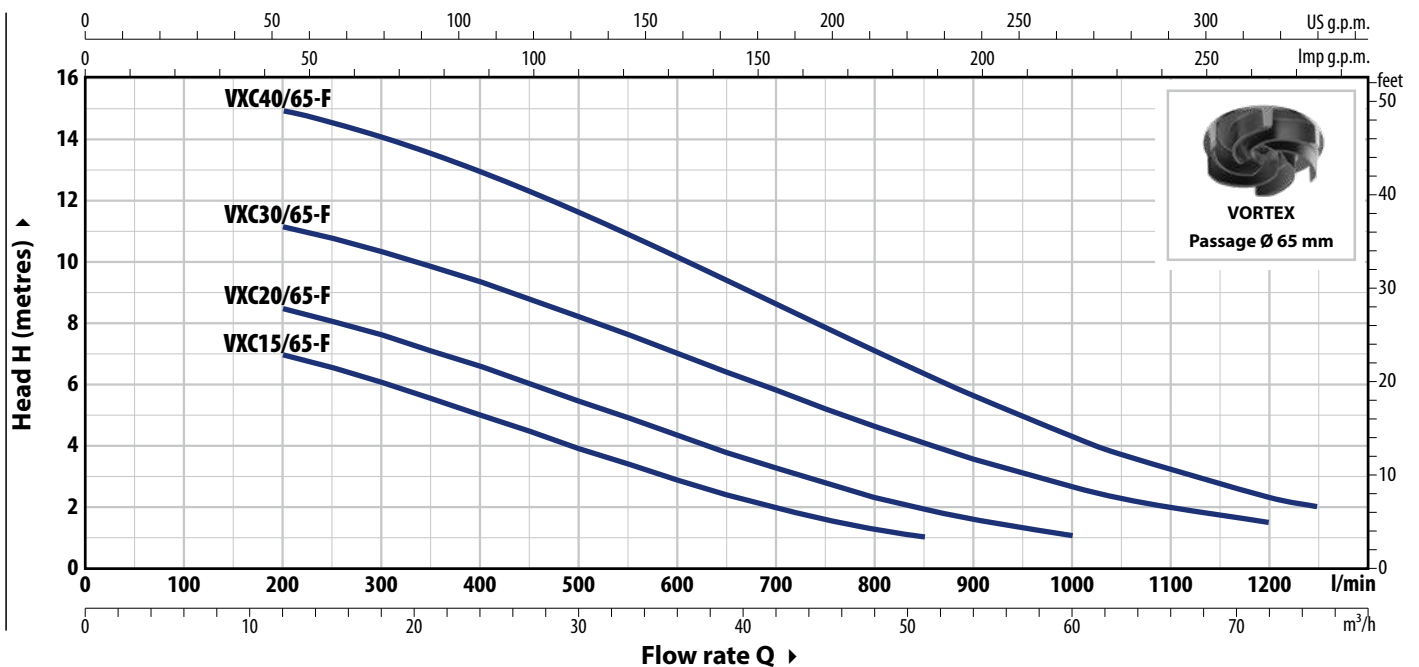

TYPE		POWER (P ₂)		Q	Flow rate												
Single-phase	Three-phase	kW	HP		m ³ /h	0	12	24	36	42	51	60	63	72	75		
VXCm 15/65-F	VXC 15/65-F	1.1	1.5	H metres	0	200	400	600	700	850	1000	1050	1200	1250			
VXCm 20/65-F	VXC 20/65-F	1.5	2		8	7	5	2.8	2	1							
VXCm 30/65-F	VXC 30/65-F	2.2	3		9.5	8.5	6.6	4.3	3.3	2	1						
-	VXC 40/65-F	3	4		12	11	9.3	7	5.8	4	2.6	2.3	1.5				
					15.5	15	13	10	8.6	6.3	4.3	3.7	2.3	2			

Q = Flow rate H = Total manometric head

Performance curves comply with EN ISO 9906 Grade 3B tolerance limits.

ABSORPTION

TYPE	VOLTAGE
Single-phase	230 V
VXCm 15/50-F	8.5 A
VXCm 20/50-F	9.0 A
VXCm 30/50-F	12.0 A
VXCm 15/65-F	8.5 A
VXCm 20/65-F	9.0 A
VXCm 30/65-F	12.0 A

TYPE	VOLTAGE
Three-phase	400 V
VXC 15/50-F	3.4 A
VXC 20/50-F	3.7 A
VXC 30/50-F	5.0 A
VXC 40/50-F	6.2 A
VXC 15/65-F	3.4 A
VXC 20/65-F	3.7 A
VXC 30/65-F	5.0 A
VXC 40/65-F	6.2 A

DIMENSIONS AND WEIGHT

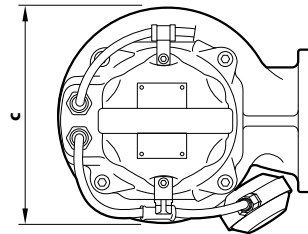
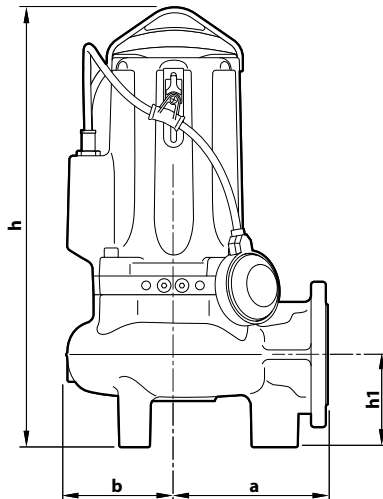

TYPE		Passage of solid bodies	DIMENSIONS mm					kg	
Single-phase	Three-phase		a	b	c	h	h1	1~	3~
VXCm 15/50-F	VXC 15/50-F	50 mm	170	119	242	487	102	43.6	42.0
VXCm 20/50-F	VXC 20/50-F					513 487		44.6	43.3
VXCm 30/50-F	VXC 30/50-F					513		49.5	45.5
-	VXC 40/50-F					-		-	50.0
VXCm 15/65-F	VXC 15/65-F	65 mm	210	120	246	521	123	46.0	44.7
VXCm 20/65-F	VXC 20/65-F					547 521		47.1	46.0
VXCm 30/65-F	VXC 30/65-F					547		51.8	48.0
-	VXC 40/65-F					-		-	51.8

PORT FLANGE

TYPE	FLANGE	F	K	D	L	HOLES	
						N°	Ø (mm)
VXC /50-F	DN65 (PN10)	2½"	145	185	160	4	18
VXC /65-F	DN80 (PN10)	3"	160	200	180	8	18

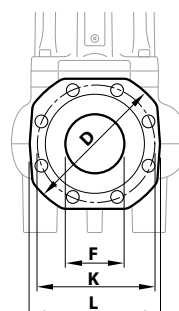

MATERIALS AND COMPONENTS

1 Pump body	Cast iron with cathoporesis treatment with flanged and threaded ISO 228/1 port		
2 Impeller	Cast iron VORTEX type with cathoporesis treatment		
3 Motor holder	Cast iron with cathoporesis treatment		
4 Motor bracket	Cast iron with cathoporesis treatment		
5 Motor shaft	Stainless steel AISI 431		
6 Double mechanical seal with interposed oil chamber			
Seal	Shaft	Location	Materials
STA-22	Ø 22 mm	Motor side	Ceramic / Graphite / NBR
STA-20	Ø 20 mm	Pump side	Silicon carbide/Silicon carbide/NBR

7 Electric Motor

VXCm-F: single-phase 230 V - 50 Hz
with thermal motor protection

VXC-F: three-phase 400 V - 50 Hz

✘ with winding integrated thermal motor protection (to be connected to the switchboard supplied on request)

- Insulation: class F
- Protection rating: IP X8

8 Power cord

✘ 10 metres 'H07 RN-F' type

9 Switchboard

(exclusive to single-phase models)

With capacitor and manual reset motor protection switch

10 Float switch

(exclusive to single-phase models)

Power switchboard
(standard for single-phase versions)

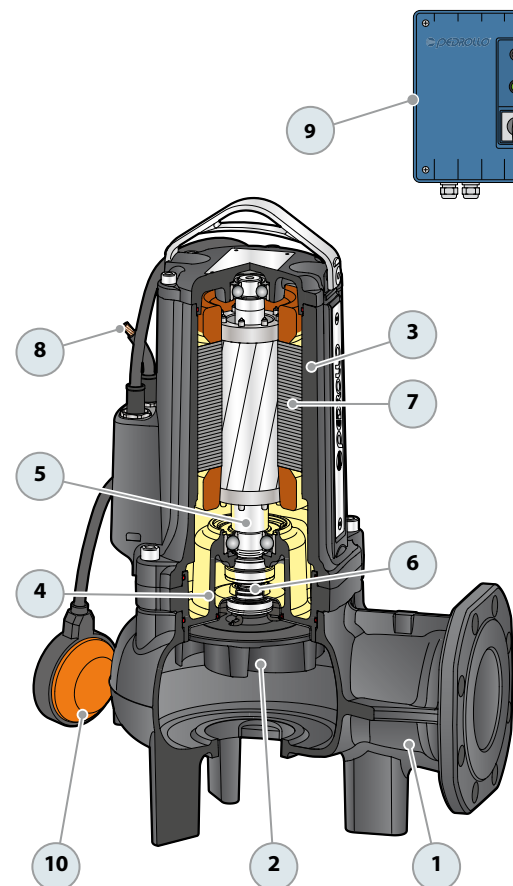
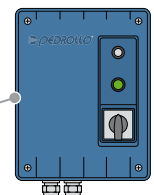

OPTIONAL - Support base

(Cod. ASSBAVM)





Sewage



Civil use



Industrial use

※ **High quality materials and robustness assure superior performance and reliability**



PERFORMANCE RANGE

- Flow rate up to **1600 l/min** (96 m³/h)
- Head up to **25 m**

INSTALLATION AND USE

The **MC-F** series is constructed from thick cast iron, offering exceptional robustness, abrasion resistance, and longevity. Featuring **TWO-CHANNEL** impellers, these pumps are designed to drain liquids containing suspended solids and short fibers, as well as wastewater, **sewage, sludge-mixed water, groundwater, and surface water** in various settings including apartment buildings, public facilities, industrial sites, parking facilities, and washing areas.

APPLICATION LIMITS

- Depth below water level up to **10 m** (with an appropriately sized power cable)
- Liquid temperature up to **+40 °C**
- Suspended solids transfer:
 - up to **Ø 50 mm** for **MC /50-F**
 - up to **Ø 65 mm** for **MC /65-F**
- **Minimum immersion for continuous service:**
 - **320 mm** for **MC /50**
 - **360 mm** for **MC /65**

INCLUDES

- ※ Power cable length **10 m**
- ※ Float switch (exclusive to single-phase models)
- ※ Switchbox compatible with single-phase versions

AVAILABLE UPON REQUEST

- ※ Coupling foot kit
- ※ **QES** control panel for three-phase pumps
- ※ Different voltage requirements 60 Hz frequency

WARRANTY

- ※ **The warranty for three-phase models remains valid only if the motor's built-in thermal protector is properly connected to the control panel. This connection is essential for the warranty's applicability.**

PATENTS - TRADE MARKS - MODELS

- Patent No. IT0001428923

CURVES AND PERFORMANCE DATA

50 Hz

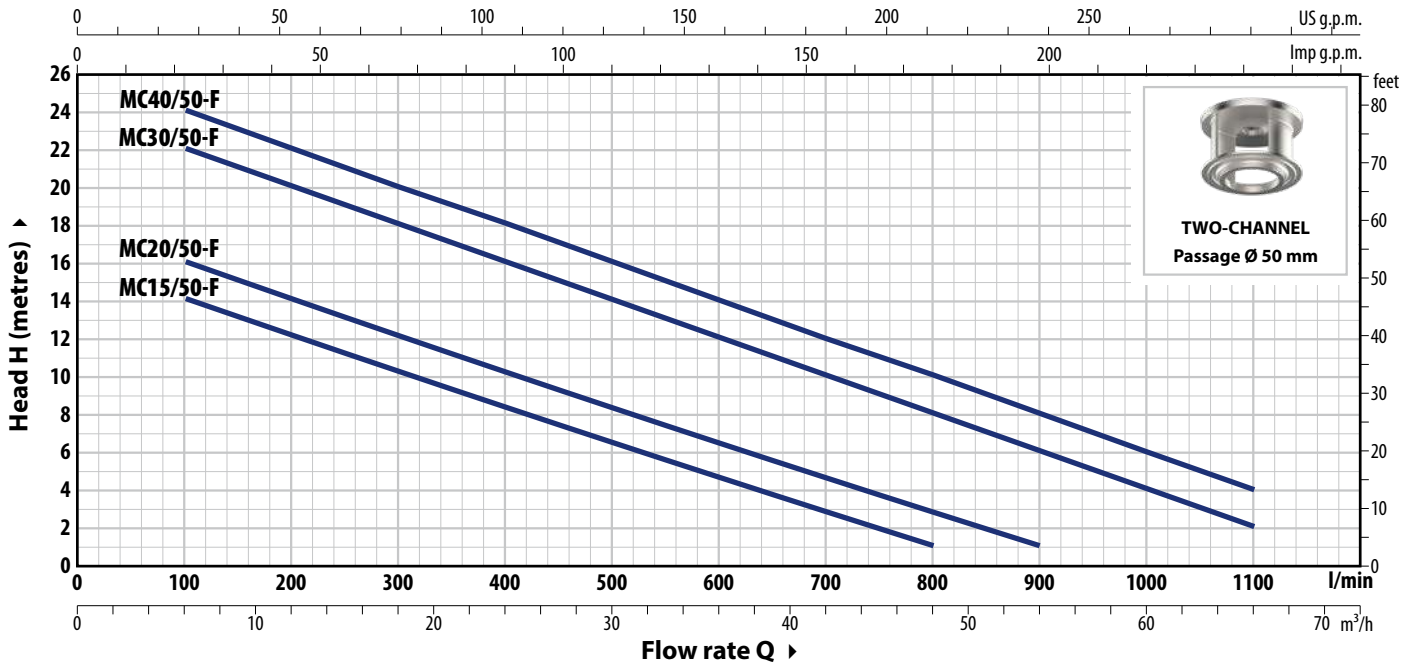

TYPE		POWER (P ₂)		Q	H metres												
Single-phase	Three-phase	kW	HP		m ³ /h	0	6	12	18	24	30	36	42	48	54	60	66
				l/min	0	100	200	300	400	500	600	700	800	900	1000	1100	
MCm 15/50-F	MC 15/50-F	1.1	1.5	H metres	16	14	12.5	10.5	8.5	6.5	4.5	3	1				
MCm 20/50-F	MC 20/50-F	1.5	2		18	16	14	12.5	10.5	8.5	6.5	5	3	1			
MCm 30/50-F	MC 30/50-F	2.2	3		24	22	20	18	16	14	12	10	8	6	4	2	
-	MC 40/50-F	3	4		25	24	22	20	18	16	14	12	10	8	6	4	

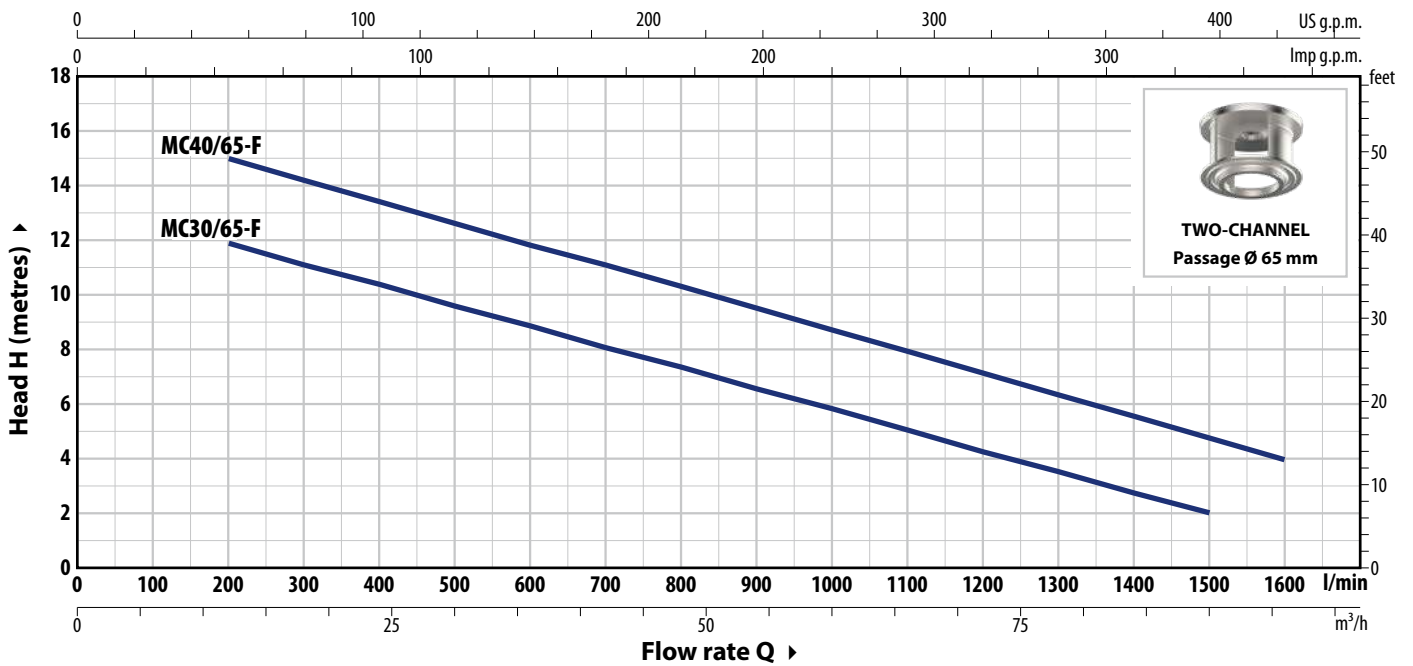

TYPE		POWER (P ₂)		Q	H metres										
Single-phase	Three-phase	kW	HP		m ³ /h	0	12	24	36	48	60	66	72	90	96
				l/min	0	200	400	600	800	1000	1100	1200	1500	1600	
MCm 30/65-F	MC 30/65-F	2.2	3	H metres	13	12	10.5	9	7.5	6	5	4.5	2		
-	MC 40/65-F	3	4		17	15	13.5	12	10.5	8.5	8	7	4.8	4	

Q = Flow rate H = Total manometric head

Performance curves comply with EN ISO 9906 Grade 3B tolerance limits.

ABSORPTION

TYPE	VOLTAGE
Single-phase	230 V
MCm 15/50-F	10.5 A
MCm 20/50-F	14.0 A
MCm 30/50-F	18.0 A
MCm 30/65-F	14.0 A

TYPE	VOLTAGE
Three-phase	400 V
MC 15/50-F	4.5 A
MC 20/50-F	5.0 A
MC 30/50-F	6.5 A
MC 40/50-F	7.0 A
MC 30/65-F	6.5 A
MC 40/65-F	7.5 A

DIMENSIONS AND WEIGHT

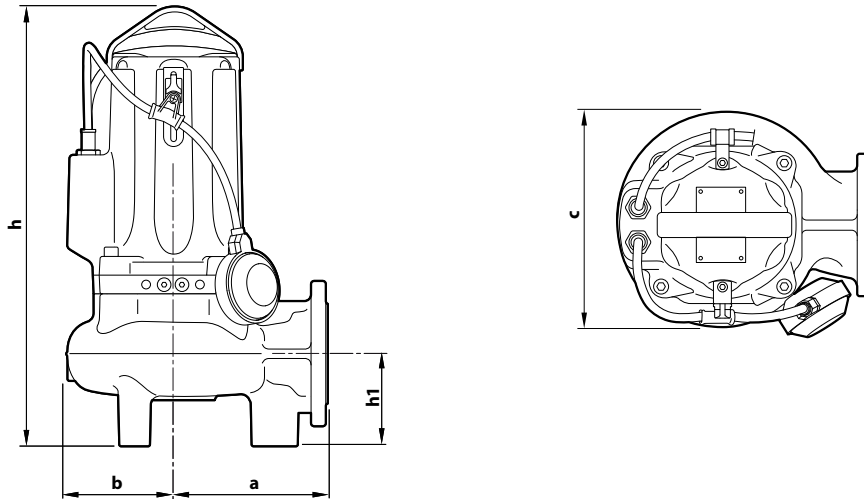

TYPE		Passage of solid bodies	DIMENSIONS mm					kg	
Single-phase	Three-phase		a	b	c	h	h1	1~	3~
MCm 15/50-F	MC 15/50-F	50 mm	170	119	242	487	102	43.6	42.0
MCm 20/50-F	MC 20/50-F					513 487		44.6	43.5
MCm 30/50-F	MC 30/50-F					513		50.0	45.5
-	MC 40/50-F					513		-	49.8
MCm 30/65-F	MC 30/65-F	65 mm	210	120	246	547 521	123	51.8	48.0
-	MC 40/65-F					547		-	52.8

PORT FLANGE

TYPE	FLANGE	F	K	D	L	HOLES	
						N°	Ø (mm)
MC /50-F	DN65 (PN10)	2½"	145	185	160	4	18
MC /65-F	DN80 (PN10)	3"	160	200	180	8	18

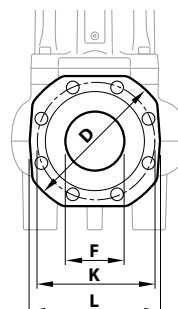

MATERIALS AND COMPONENTS

1 Pump body	Cast iron with cathoporesis treatment with flanged and threaded ISO 228/1 port		
2 Impeller	TWO-CHANNEL type in micro-cast AISI 304 stainless steel		
3 Motor holder	Cast iron with cathoporesis treatment		
4 Motor bracket	Cast iron with cathoporesis treatment		
5 Motor shaft	Stainless steel AISI 431		
6 Double mechanical seal with interposed oil chamber			
Seal	Shaft	Location	Materials
STA-22	Ø 22 mm	Motor side	Ceramic / Graphite / NBR
STA-20	Ø 20 mm	Pump side	Silicon carbide/Silicon carbide/NBR

7 Electric Motor

MCm-F: single-phase 230 V - 50 Hz
with thermal motor protection

MC-F: three-phase 400 V - 50 Hz
✘ with winding integrated thermal motor protection
(to be connected to the switchboard supplied on request)

- Insulation: class F
- Protection rating: IP X8

Power switchboard
(standard for single-phase versions)

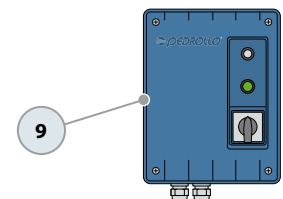

8 Power cord

✘ 10 metres 'H07 RN-F' type

9 Switchboard

(exclusive to single-phase models)

With capacitor and manual reset motor protection switch

10 Float switch

(exclusive to single-phase models)

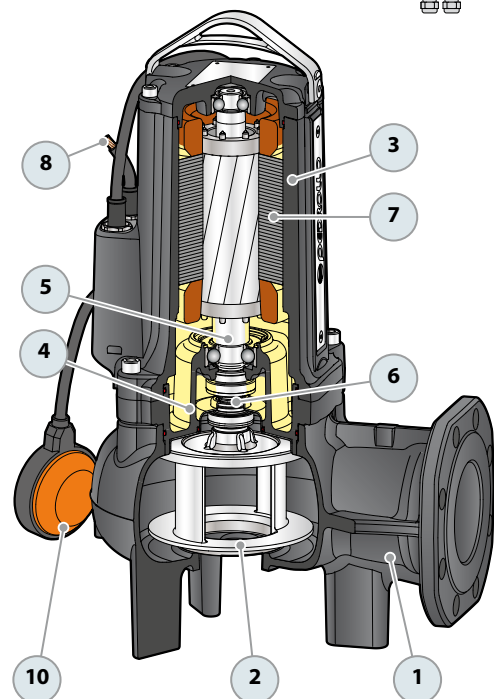

OPTIONAL - Support base

(Cod. ASSBAVM)



SEWAGE LIFTING SYSTEM VXC-F - MC-F

VERSION WITH HORIZONTAL DELIVERY AND 3/4" GUIDE PIPES

For VXC /50-F, MC /50-F	Code ASSVXCF051	DN 2"
--------------------------------	-----------------	--------------

※ Kit consisting of:



Coupling foot



Slide rail with screws and gasket



Support for guide tubes



VERSION WITH VERTICAL DELIVERY AND 3/4" GUIDE PIPES

For VXC /50-F, MC /50-F	Code ASSVXCF051V	DN 2 1/2"
For VXC /65-F, MC /65-F	Code ASSVXCF071V	DN 3"

VERSION WITH VERTICAL DELIVERY AND 2" GUIDE TUBES

For VXC /50-F, MC /50-F	Code ASSVXCF0704V	DN 3"
For VXC /65-F, MC /65-F	Code ASSVXCF0705V	

※ Kit consisting of:



Coupling foot complete with counterflange



Slide rail with screws and gasket



Support for guide tubes



● ACCESSORIES AVAILABLE FOR ORDER

RUNNING GUIDE

※ For VXC /50-F, MC /50-F with guide tubes Ø 3/4".	Code ASSFL0017
※ For VXC /65-F, MC /65-F with guide tubes Ø 3/4".	Code ASSFL0018
※ For VXC /50-F, MC /50-F with guide tubes Ø 2".	Code ASSFL071
※ For VXC /65-F, MC /65-F with guide tubes Ø 2".	Code ASSFL072

Complete with screws and seals



for Ø 3/4" guide tubes



for guide tubes Ø 2"

INTERMEDIATE GUIDE TUBE SUPPORT

※ For Ø 3/4" guide tubes	Code 859SV340INTFA
※ For guide tubes Ø 2"	Code 859SV349INTFA

For reasons of stability, interpose a support:

- every 2 metres with 3/4 " guide pipes (mandatory)
- every 3 metres with 2" guide tubes (recommended)



for Ø 3/4" guide tubes



for guide tubes Ø 2"

GUIDE TUBE (AISI 304 stainless steel)

※ 2 metres Ø 3/4" guide tube	Code 54SARTG0052F
※ 3 metres Ø 3/4" guide tube	Code 54SARTG0053F
※ 6 metres Ø 3/4" guide tube	Code 54SARTG0056F
※ 3 metres Ø 2" guide tube	Code 54SARTG0063F
※ 6 metres guide tube Ø 2"	Code 54SARTG0066F



DIMENSIONS (Version with horizontal outlet)

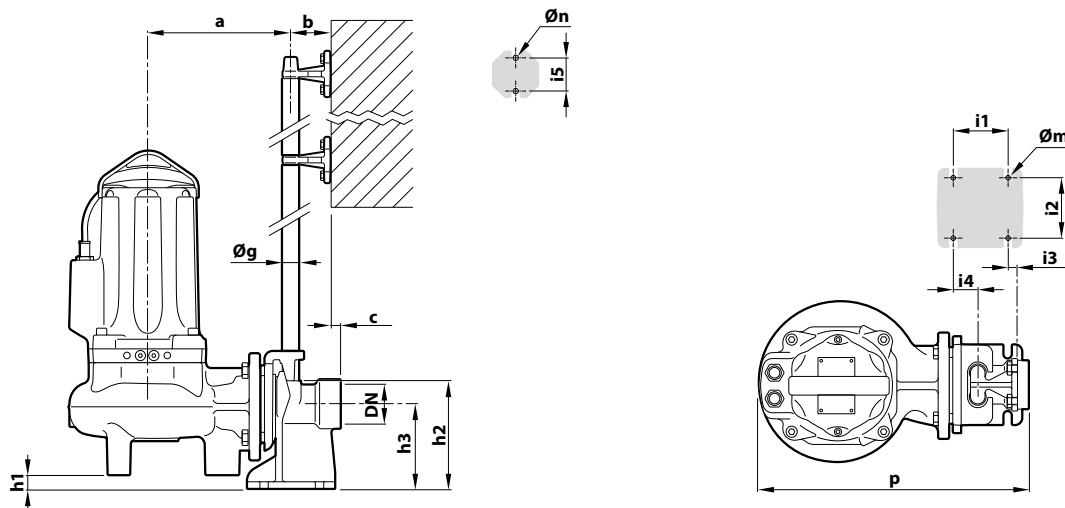

TYPE	Solid bodies mm	PORT DN	DIMENSIONS mm														
			a	b	c	p	h1	h2	h3	i1	i2	i3	i4	i5	Øg	Øm	Øn
VXC /50 -F	Ø 50	2"	216	61	17	412	28	165	130	85	94	16	40	50	¾"	12	11
MC /50 -F																	

DIMENSIONS (Version with vertical delivery)

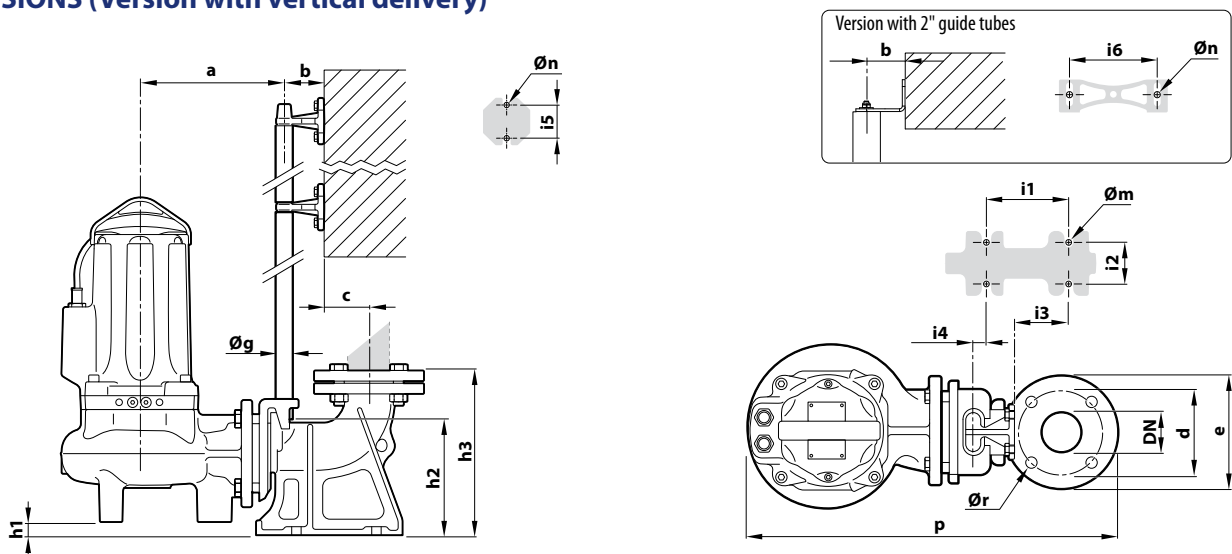

Version with ¾" guide tubes

TYPE	Solid bodies mm	PORT DN	DIMENSIONS mm																	
			a	b	c	d	e	p	h1	h2	h3	i1	i2	i3	i4	i5	Øg	Øm	Øn	Ør
VXC /50 -F	Ø 50 mm	2½"	213	61	52	125	165	526	25.5	164	215	120	72	62	3	50	¾"	14	11	18
MC /50 -F																				
VXC /65 -F	Ø 65 mm	3" (PN6)	253	61	69	150	190	598	46	216	279	130	112	84	15	50	¾"	14	11	18
MC /65 -F																				

Version with 2" guide tubes

TYPE	Solid bodies mm	PORT DN	DIMENSIONS mm																		
			a	b	c	d	e	p	h1	h2	h3	i1	i2	i3	i4	i5	i6	Øg	Øm	Øn	Ør
VXC /50 -F	Ø 50 mm	3" (PN10)	320	85	95	160	200	718	105	265	392	250	150	35	-130	-	187	2"	22	13.5	18
MC /50 -F																					
VXC /65 -F	Ø 65 mm	3" (PN10)	359	85	95	160	200	760	84	256	392	250	150	35	-130	-	187	2"	22	13.5	18
MC /65 -F																					

-  Sewage
-  Civil use
-  Industrial use

※ **Advanced design and high-quality materials assure long-term performance and reliability**



PERFORMANCE RANGE

- Flow rate up to **1800 l/min** (108 m³/h)
- Head up to **26 m**

INSTALLATION AND USE

The **VX** series is constructed from thick stainless steel and cast iron, offering exceptional robustness, abrasion resistance, and durability. The pumps feature **VORTEX**-type impellers, renowned for their reliable operation and minimal risk of clogging.

Recommended for various applications including sewage with suspended solids, wastewater, rainwater, city sewage, and industrial wastewater.

They are suitable for a wide range of applications, including sewers, tunnels, excavations, canals, and underground parking facilities.

ELECTRIC MOTOR

※ **The electric motor is safeguarded by a special three-phase thermal protector, situated within the motor, which activates in case of overheating or abnormal power consumption.**

INCLUDES

- ※ Power cable length **10 m**

APPLICATION LIMITS

- Depth below water level up to **10 m** (with an appropriately sized power cable)
- Liquid temperature up to **+40 °C**
- Suspended solids transfer:
 - up to **Ø 50 mm** for VX/50
 - up to **Ø 65 mm** for VX/65
 - up to **Ø 80 mm** for VX/80
- **Minimum immersion for continuous service: 500 mm**

AVAILABLE UPON REQUEST

- ※ Different voltage requirements 60 Hz frequency

PATENTS - TRADE MARKS - MODELS

- Registered Community Model No. 003863158-0002

CURVES AND PERFORMANCE DATA

50 Hz

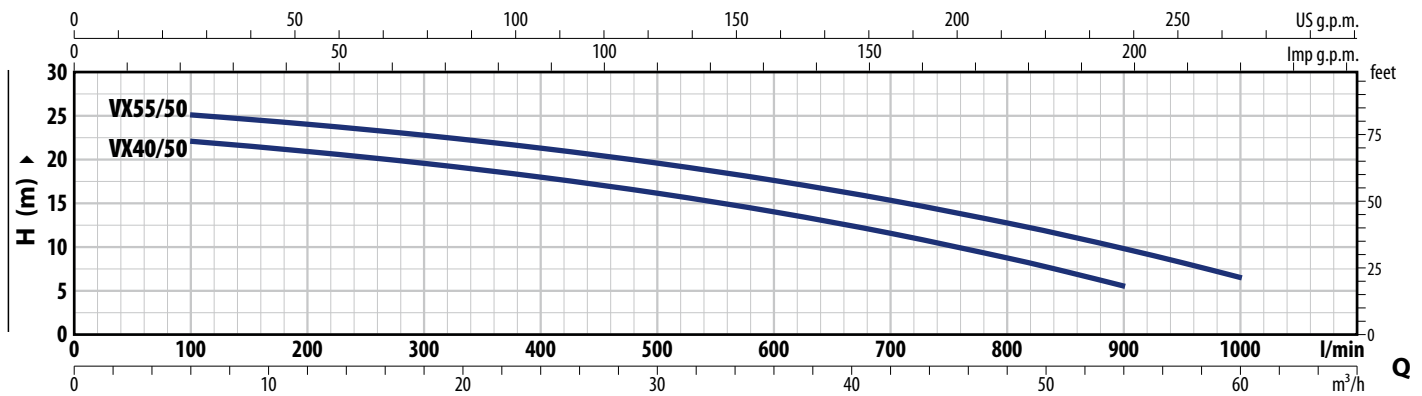

TYPE Three-phase	POWER (P ₂)		Q	m ³ /h												
	kW	HP		0	6	12	18	24	30	36	42	48	54	60		
VX 40/50	3	4	H metres	23	22	20.8	19.5	18	16	14	11.5	8.7	5.5			
VX 55/50	4	5.5	H metres	26	25	24	22.7	21.2	19.5	17.5	15.3	12.7	9.8	6.5		

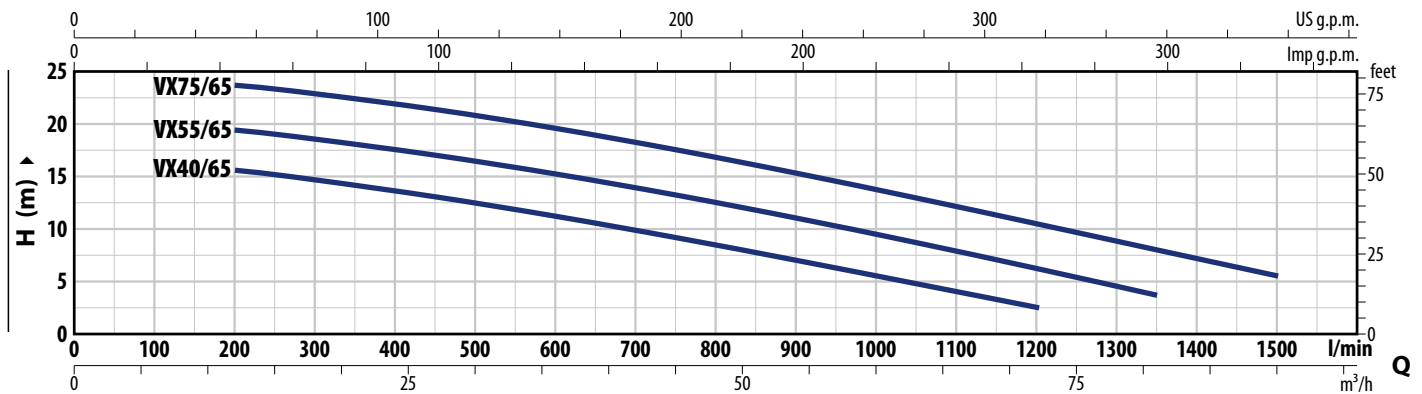

TYPE Three-phase	POWER (P ₂)		Q	m ³ /h												
	kW	HP		0	12	18	27	36	45	54	63	72	81	90		
VX 40/65	3	4	H metres	17	15.6	14.7	13	11.2	9.2	7	4.8	2.5				
VX 55/65	4	5.5	H metres	20.7	19.4	18.5	17	15.2	13.2	11	8.7	6.2	3.7			
VX 75/65	5.5	7.5	H metres	24.8	23.6	23	21.4	19.6	17.5	15.2	13	10.5	8	5.5		

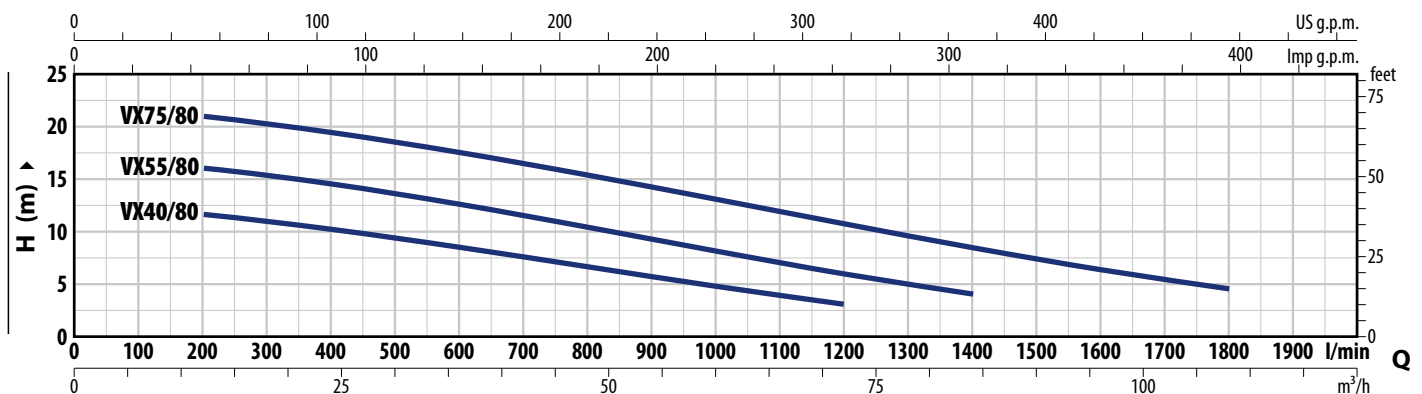

TYPE Three-phase	POWER (P ₂)		Q	m ³ /h												
	kW	HP		0	12	24	36	48	60	72	84	96	108			
VX 40/80	3	4	H metres	12.5	11.5	10.2	8.5	6.7	5	3						
VX 55/80	4	5.5	H metres	16.5	16	14.4	12.5	10.3	8	6	4					
VX 75/80	5.5	7.5	H metres	22	21	19.2	17.4	15.2	13	10.7	8.4	6.4	4.5			

Q = Flow rate H = Total manometric head

Performance curves comply with EN ISO 9906 Grade 3B tolerance limits.

ABSORPTION

TYPE	VOLTAGE
Three-phase	400 V
VX 40/50	5.8 A
VX 55/50	7.0 A
VX 40/65	6.2 A
VX 55/65	7.7 A
VX 75/65	12.7 A

TYPE	VOLTAGE
Three-phase	400 V
VX 40/80	6.0 A
VX 55/80	8.5 A
VX 75/80	13.5 A

DIMENSIONS AND WEIGHT

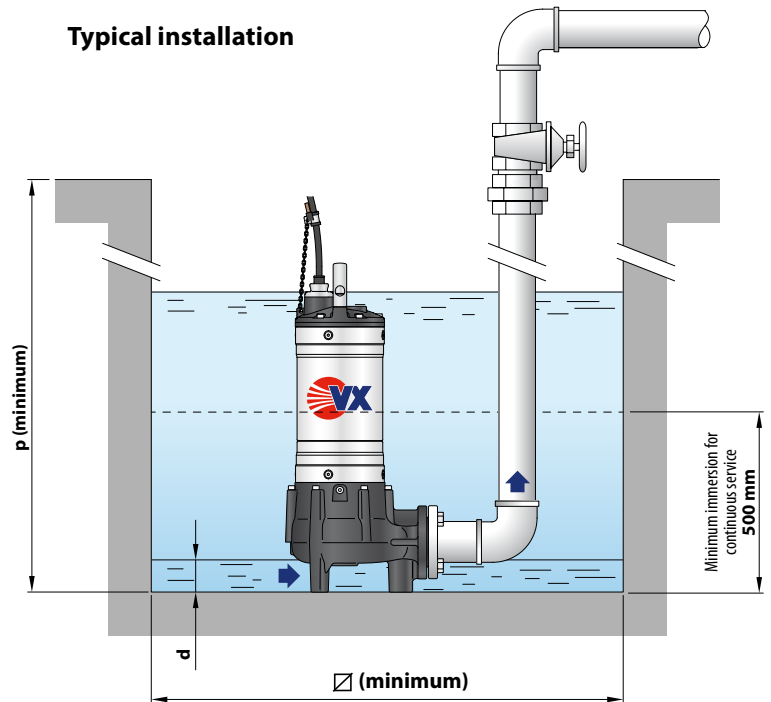
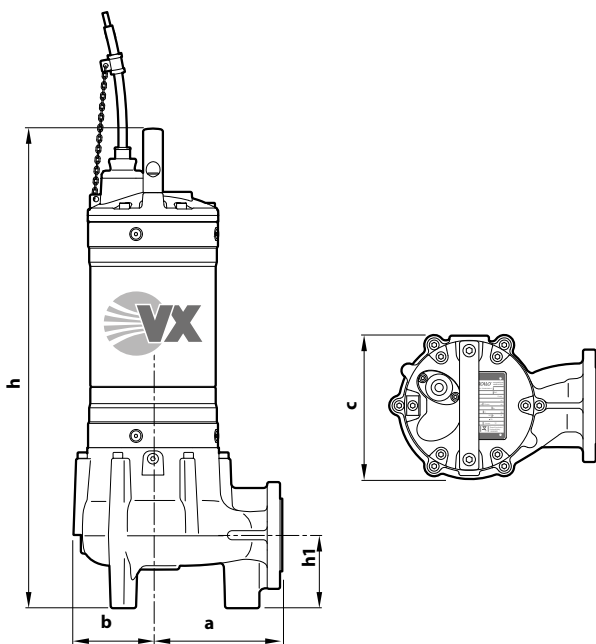

TYPE	Passage of solid bodies	DIMENSIONS mm								kg
		a	b	c	h	h1	d	p	∅	
Three-phase	∅ 50 mm	170	106	193	602	100	55	700	500	3~
VX 40/50					642	50.0				
VX 55/50					630	59.0				
VX 40/65	∅ 65 mm	170	107	196	670	121	70	800	500	54.0
VX 55/65					700	60.0				
VX 75/65					655	67.0				
VX 40/80	∅ 80 mm	178	107	210	695	150	85	800	500	54.8
VX 55/80					725	60.0				
VX 75/80					68.0					

PORT FLANGE

TYPE	FLANGE	F	K	D	HOLES	
					N°	∅ (mm)
Three-phase	DN		mm	mm		
VX 40/50	50	2"	125	150	4	18
VX 55/50	(PN10)					
VX 40/65	65	2½"	145	185	8	18
VX 55/65	(PN10)					
VX 75/65						
VX 40/80	80	3"	160	200	8	18
VX 55/80	(PN10)					
VX 75/80						

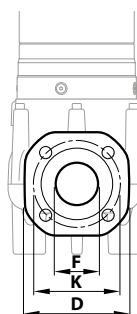

PALLET CAPACITY

TYPE	NO. OF PUMPS
Three-phase	
VX 40/50	10
VX 55/50	12
VX 40/65	12
VX 55/65	12
VX 75/65	12
VX 40/80	12
VX 55/80	12
VX 75/80	12

MATERIALS AND COMPONENTS

1 Pump body Cast iron with cataphoresis treatment

2 Impeller Cast iron VORTEX type with cataphoresis treatment

3 Motor sleeve Stainless steel **AISI 304**

4 Motor cover Cast iron with cataphoresis treatment

5 Motor shaft Stainless steel **AISI 431**

6 Double mechanical seal with interposed oil chamber

Water pump	Seal	Shaft	Location	Materials
VX 50	ED560-25	Ø 25 mm	Motor side	Silicon carbide / Graphite / NBR
			Pump side	Silicon carbide/Silicon carbide/NBR
VX 65-80	AR-27	Ø 27 mm	Motor side	Silicon carbide / Graphite / NBR
	AR-25	Ø 25 mm	Pump side	Silicon carbide/Silicon carbide/NBR

7 Electric Motor

Three-phase 400 V - 50Hz
with winding integrated thermal motor protection

- Insulation: class F
- Protection rating: IP X8

8 Power cord

※ 10 metres 'H07 RN-F' type

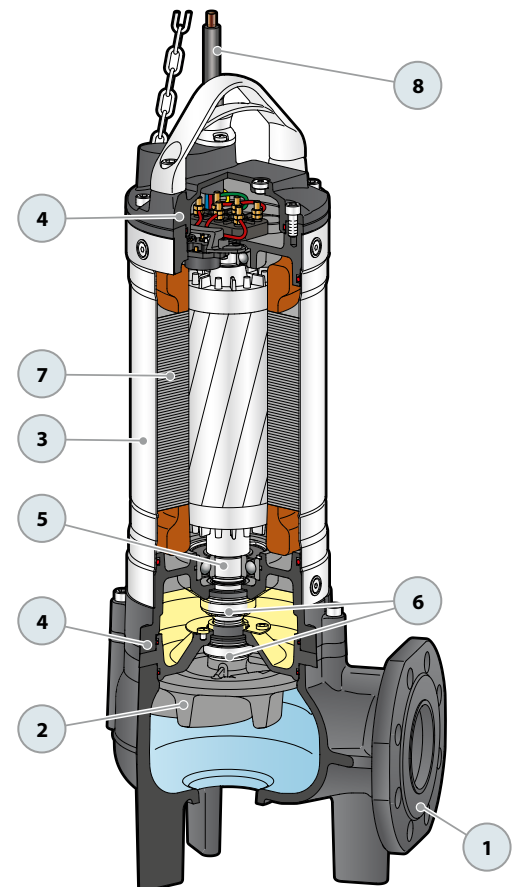

-  Sewage
-  Civil use
-  Industrial use

※ **Advanced design and high-quality materials assure long-term performance and reliability**



PERFORMANCE RANGE

- Flow rate up to **2300 l/min** (138 m³/h)
- Head up to **31 m**

INSTALLATION AND USE

The **BC** series is constructed from thick stainless steel and cast iron, offering exceptional robustness, abrasion resistance, and durability. Equipped with **TWO-CHANNEL** impellers, the pumps are designed to drain **sewage, sludge-mixed water, and activated and putrid sludge**.

They are suitable for a wide range of applications, including sewers, tunnels, excavations, canals, and underground parking facilities.

ELECTRIC MOTOR

※ **The electric motor is safeguarded by a special three-phase thermal protector, situated within the motor, which activates in case of overheating or abnormal power consumption.**

INCLUDES

- ※ Power cable length **10 m**

APPLICATION LIMITS

- Depth below water level up to **10 m** (with an appropriately sized power cable)
- Liquid temperature up to **+40 °C**
- Suspended solids transfer:
 - up to **Ø 35 mm** for BC/35
 - up to **Ø 50 mm** for BC/50
- **Minimum immersion for continuous service: 500 mm**

AVAILABLE UPON REQUEST

- ※ Different voltage requirements 60 Hz frequency

PATENTS - TRADE MARKS - MODELS

- Registered Community Model No. 003863158-0001

CURVES AND PERFORMANCE DATA

50 Hz

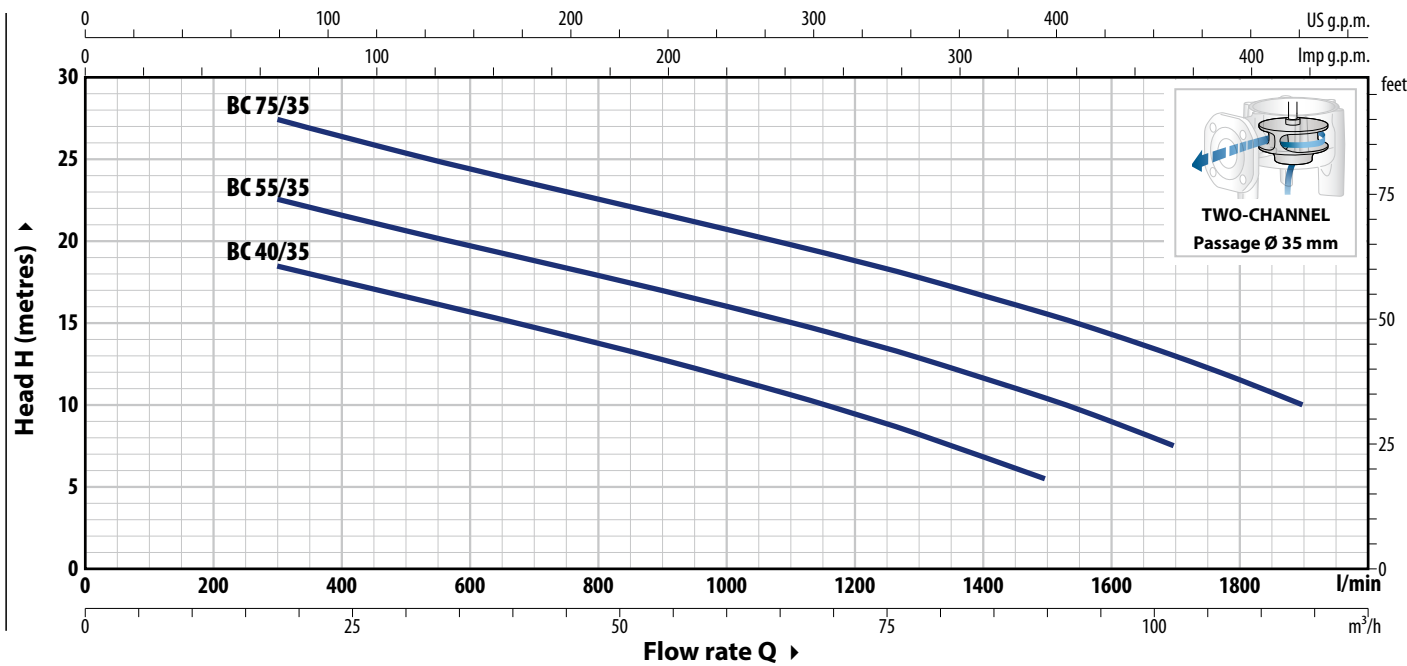

TYPE	POWER (P ₂)		Q	Flow rate											
	kW	HP		m ³ /h	0	18	30	42	54	66	78	90	102	114	
Three-phase				0	300	500	700	900	1100	1300	1500	1700	1900		
BC 40/35	3	4	H metres		21.4	18.5	16.6	14.7	12.8	10.6	8.2	5.5			
BC 55/35	4	5.5			25.8	22.5	20.6	18.8	17	15	13	10.4	7.5		
BC 75/35	5.5	7.5			31	27.5	25.4	23.5	21.6	19.8	17.8	15.6	13	10	

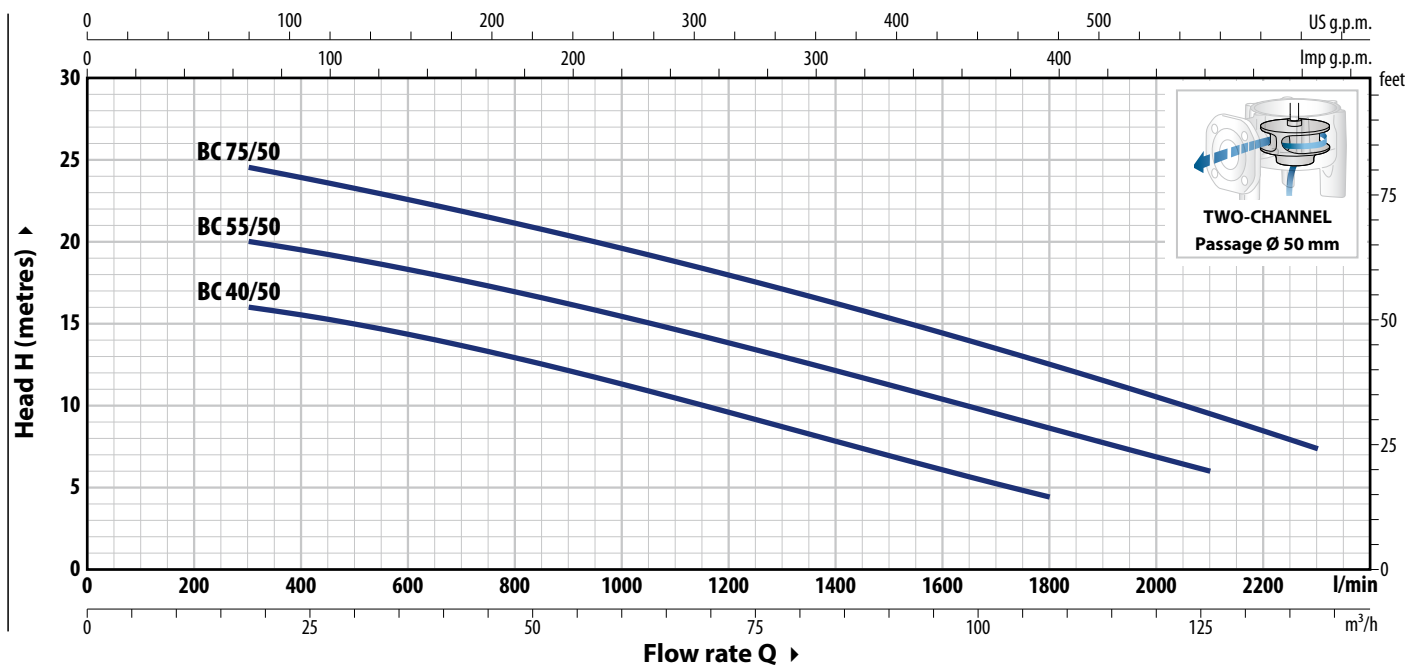

TYPE	POWER (P ₂)		Q	Flow rate											
	kW	HP		m ³ /h	0	18	30	45	60	75	90	108	126	138	
Three-phase				0	300	500	750	1000	1250	1500	1800	2100	2300		
BC 40/50	3	4	H metres		16.5	16	14.8	13	11	9	6.8	4.5			
BC 55/50	4	5.5			21.5	20	19	17.5	15.6	13.5	11.3	8.7	6		
BC 75/50	5.5	7.5			26.5	24.5	23.2	21.5	19.6	17.5	15.3	12.4	9.4	7.5	

Q = Flow rate H = Total manometric head

Performance curves comply with EN ISO 9906 Grade 3B tolerance limits.

ABSORPTION

TYPE	VOLTAGE
Three-phase	400 V
BC 40/35	6.2 A
BC 55/35	8.3 A
BC 75/35	13.5 A

TYPE	VOLTAGE
Three-phase	400 V
BC 40/50	7.0 A
BC 55/50	9.0 A
BC 75/50	13.5 A

DIMENSIONS AND WEIGHT

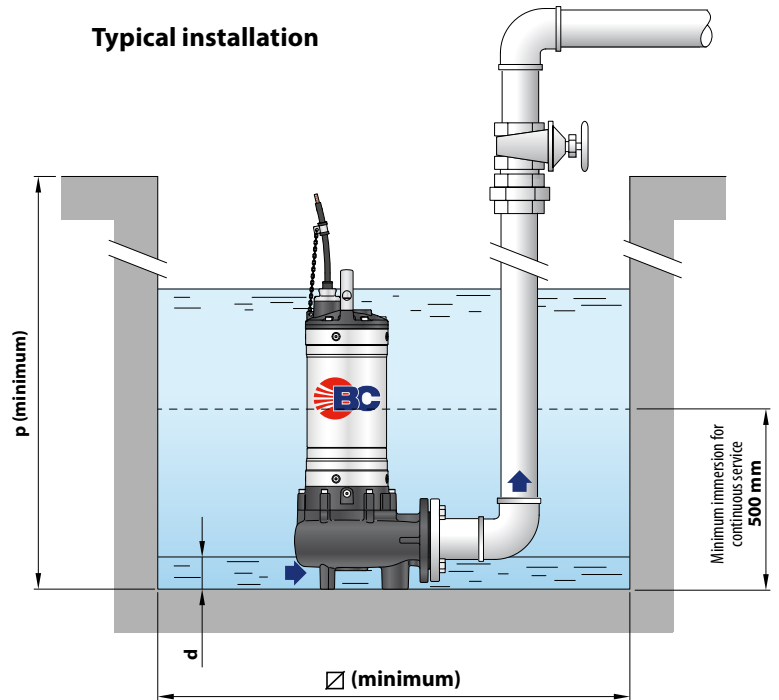
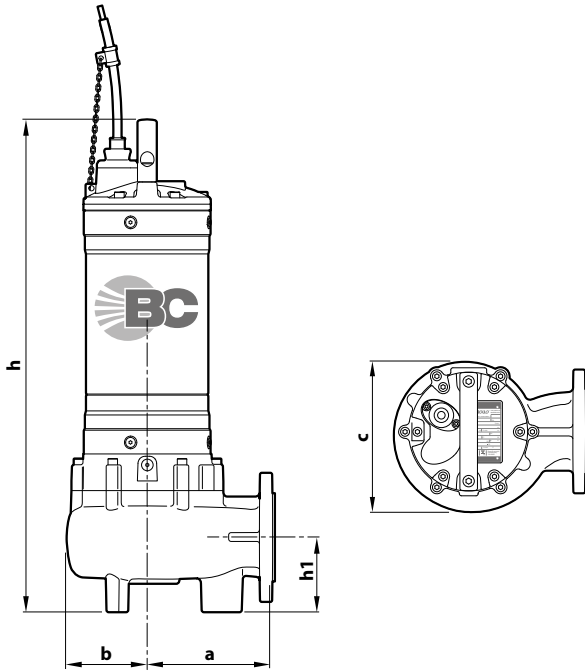

TYPE	Passage of solid bodies	DIMENSIONS mm								3~
		a	b	c	h	h1	d	p	∅	
BC 40/35	∅ 35 mm	170	113	225	595	100	40	800	500	56.0
BC 55/35					635					62.2
BC 75/35					665					67.0
BC 40/50	∅ 50 mm	178	107	210	655	150	85	800	500	58.1
BC 55/50					695					64.3
BC 75/50					725					69.1

PORT FLANGE

TYPE	FLANGE DN	F	K mm	D mm	HOLES	
					N°	∅ mm)
BC 40/35	65 (PN10)	2½"	145	185	4	18
BC 55/35						
BC 75/35						
BC 40/50	80 (PN10)	3"	160	200	8	18
BC 55/50						
BC 75/50						

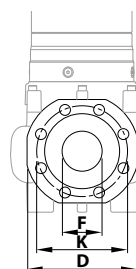

PALLET CAPACITY

TYPE	NO. OF PUMPS
Three-phase	
BC 40/35	12
BC 55/35	12
BC 75/35	12
BC 40/50	12
BC 55/50	12
BC 75/50	12

MATERIALS AND COMPONENTS

- | | |
|-----------------------|--|
| 1 Pump body | Cast iron with cathoresis treatment |
| 2 Impeller | TWO-CHANNEL cast iron type with cathoresis treatment |
| 3 Motor sleeve | Stainless steel AISI 304 |
| 4 Motor cover | Cast iron with cathoresis treatment |
| 5 Motor shaft | Stainless steel AISI 431 |

6 Double mechanical seal with interposed oil chamber

Seal	Shaft	Location	Materials
AR-27	Ø 27 mm	Motor side	Silicon carbide / Graphite / NBR
AR-25	Ø 25 mm	Pump side	Silicon carbide/Silicon carbide/NBR

7 Electric Motor

Three-phase 400 V - 50Hz
with winding integrated thermal motor protection

- Insulation: class F
- Protection rating: IP X8

8 Power cord

※ 10 metres 'H07 RN-F' type

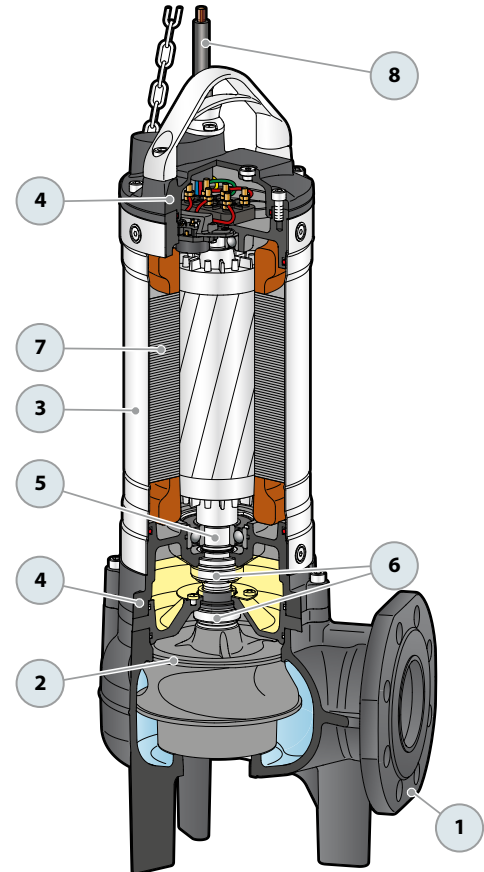

SEWAGE LIFTING SYSTEM VX - BC

VERSION WITH HORIZONTAL DELIVERY AND 3/4" GUIDE PIPES

For VX /50	Code ASSPVX50	DN 2
-------------------	---------------	-------------

※ Kit consisting of:



Coupling foot



Guide rail



Support for guide tubes



VERSION WITH VERTICAL DELIVERY AND 3/4" GUIDE PIPES

For VX /50	Code ASSPVX503V	DN 2 1/2"
For VX /65, BC /35	Code ASSPVX653V	DN 3"
For BC /50	Code ASSVXCF071V	

VERSION WITH VERTICAL DELIVERY AND 2" GUIDE TUBES

For VX /50	Code ASSPVX50V	DN 3"
For VX /65, BC /35	Code ASSPVX65V	
For VX /80, BC /50	Code ASSVXCF0705V	

※ Kit consisting of:



Coupling foot complete with counterflange



Guide rail



Support for guide tubes



● ACCESSORIES AVAILABLE FOR ORDER

RUNNING GUIDE

※ For VX /50 with Ø 3/4" guide tubes	Code ASSFL009
※ For VX /65, BC /35 with Ø 3/4" guide tubes	Code ASSFL010
※ For BC /50 with Ø 3/4" guide tubes	Code ASSFL0018
※ For VX /50 with Ø 2" guide tubes	Code ASSFL050
※ For VX /65, BC /35 with Ø 2" guide tubes	Code ASSFL065
※ For VX /80, BC /50 with Ø 2" guide tubes	Code ASSFL072

Complete with screws and seals



for Ø 3/4" guide tubes



for guide tubes Ø 2"

INTERMEDIATE GUIDE TUBE SUPPORT

※ For Ø 3/4" guide tubes	Code 859SV340INTFA
※ For guide tubes Ø 2"	Code 859SV349INTFA

For reasons of stability, an intermediate support should be interposed:

- every 2 metres with 3/4" guide pipes (mandatory)
- every 3 metres with 2" guide tubes (recommended)



for Ø 3/4" guide tubes



for guide tubes Ø 2"

GUIDE TUBE (AISI 304 stainless steel)

※ 2 metres Ø 3/4" guide tube	Code 54SARTG0052F
※ 3 metres Ø 3/4" guide tube	Code 54SARTG0053F
※ 6 metres Ø 3/4" guide tube	Code 54SARTG0056F
※ 3 metres Ø 2" guide tube	Code 54SARTG0063F
※ 6 metres guide tube Ø 2"	Code 54SARTG0066F



DIMENSIONS (HORIZONTAL delivery version)

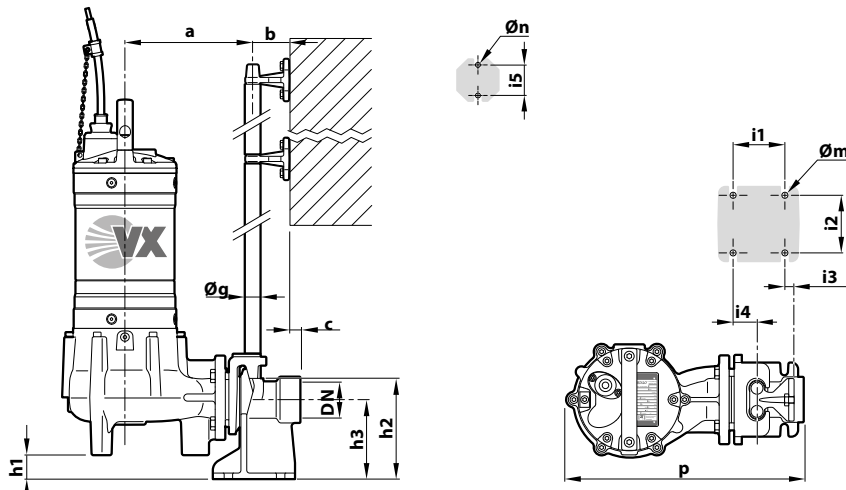

TYPE	Solid bodies mm	PORT DN	DIMENSIONS mm														
			a	b	c	p	h1	h2	h3	i1	i2	i3	i4	i5	Øg	Øm	Øn
VX /50	Ø 50	2"	214	61	17	400	30	165	130	85	94	16	40	50	¾"	12	11

DIMENSIONS (Version with VERTICAL delivery)

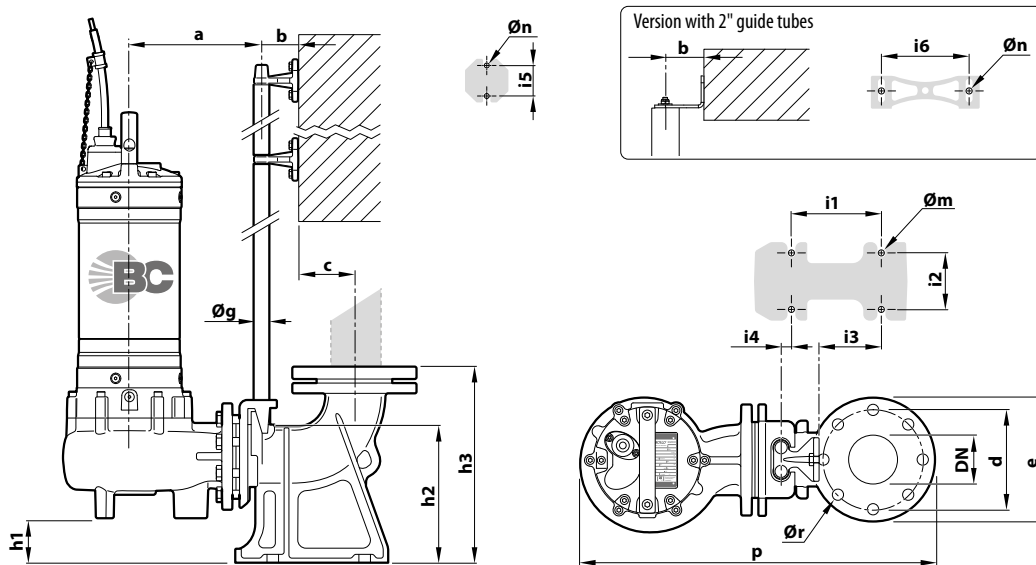

※ Version with ¾" guide tubes

TYPE	Solid bodies mm	PORT DN	DIMENSIONS mm																	
			a	b	c	d	e	p	h1	h2	h3	i1	i2	i3	i4	i5	Øg	Øm	Øn	Ør
VX /50	Ø 50 mm	2½"	211	61	52	125	165	506	28	164	216	120	72	62	3	50	¾"	14	11	18
VX /65	Ø 65 mm	3"	213		537	48														
BC /35	Ø 35 mm		231		69	150	190	550	69	216	280	130	112	84	15					
BC /50	Ø 50 mm		222		553	19														

※ Version with 2" guide tubes

TYPE	Solid bodies mm	PORT DN	DIMENSIONS mm																		
			a	b	c	d	e	p	h1	h2	h3	i1	i2	i3	i4	i5	i6	Øg	Øm	Øn	Ør
VX /50	Ø 50 mm	3"	319	86	95	160	200	706	107	264	392	250	150	34	-	80	186	2"	22	13.5	18
VX /65	Ø 65 mm							697	86												
VX /80	Ø 80 mm							714	57												
BC /35	Ø 35 mm							710	107												
BC /50	Ø 50 mm							714	57												



Sewage



Civil use



Industrial use

※ Submersible pumps 4 poles (1450 min⁻¹)



PERFORMANCE RANGE

- Flow rate up to **900 l/min** (54 m³/h)
- Head up to **7 m**

INSTALLATION AND USE

The **VX4** series is constructed from thick cast iron, offering exceptional robustness, abrasion resistance, and longevity. Equipped with **VORTEX**-type impellers, known for their reliability and minimal clogging risk, these pumps are versatile for handling sewage with suspended solids up to **80 mm** in diameter, as well as wastewater, rainwater, city sewage, and industrial wastewater. They are suitable for a wide range of applications, including sewers, tunnels, excavations, canals, and underground parking facilities.

ELECTRIC MOTOR

- ※ **The electric motor is safeguarded by a special three-phase thermal protector, situated within the motor, which activates in case of overheating or abnormal power consumption.**

INCLUDES

- ※ Power cable length **10 m**

APPLICATION LIMITS

- Depth below water level up to **10 m** (with an appropriately sized power cable)
- Liquid temperature up to **+40 °C**
- Suspended solids transfer:
 - up to **Ø 50 mm** for VX4-10/50
 - up to **Ø 65 mm** for VX4-10/65
 - up to **Ø 80 mm** for VX4-10/80
- **Minimum immersion for continuous service: 500 mm**

AVAILABLE UPON REQUEST

- ※ Different voltage requirements 60 Hz frequency

PATENTS - TRADE MARKS - MODELS

- Registered Community Model No. 003863158-0002

CURVES AND PERFORMANCE DATA – n= 1450 min⁻¹

50 Hz

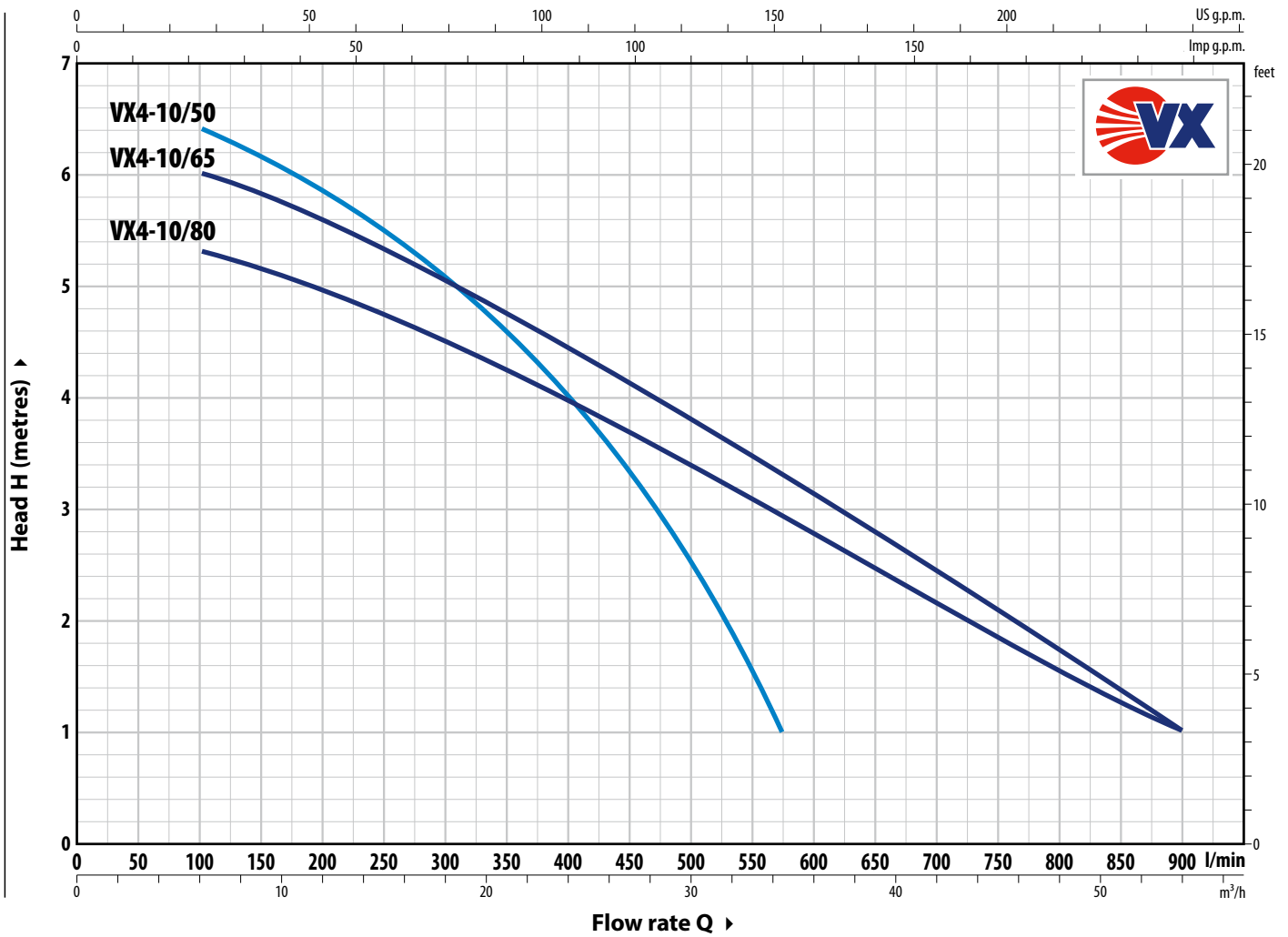

TYPE Three-phase	POWER (P ₂)		Q	Flow rate									
	kW	HP		m ³ /h	0	6	12	24	30	34.5	36	45	54
VX4-10/50	0.75	1	H metres	0	100	200	400	500	575	600	750	900	
VX4-10/65	0.75	1		7	6.4	5.8	5	4	2.5	1			
VX4-10/80	0.75	1		6	6	5.6	5	4.4	3.8	3.3	2	1	
				5.5	5.3	4.9	4.5	3.9	3.4	2.9	1.8	1	

Q = Flow rate H = Total manometric head

Performance curves comply with EN ISO 9906 Grade 3B tolerance limits.

ABSORPTION

TYPE	VOLTAGE
Three-phase	400 V
VX4-10/50	2.7 A
VX4-10/65	2.7 A
VX4-10/80	2.7 A

DIMENSIONS AND WEIGHT

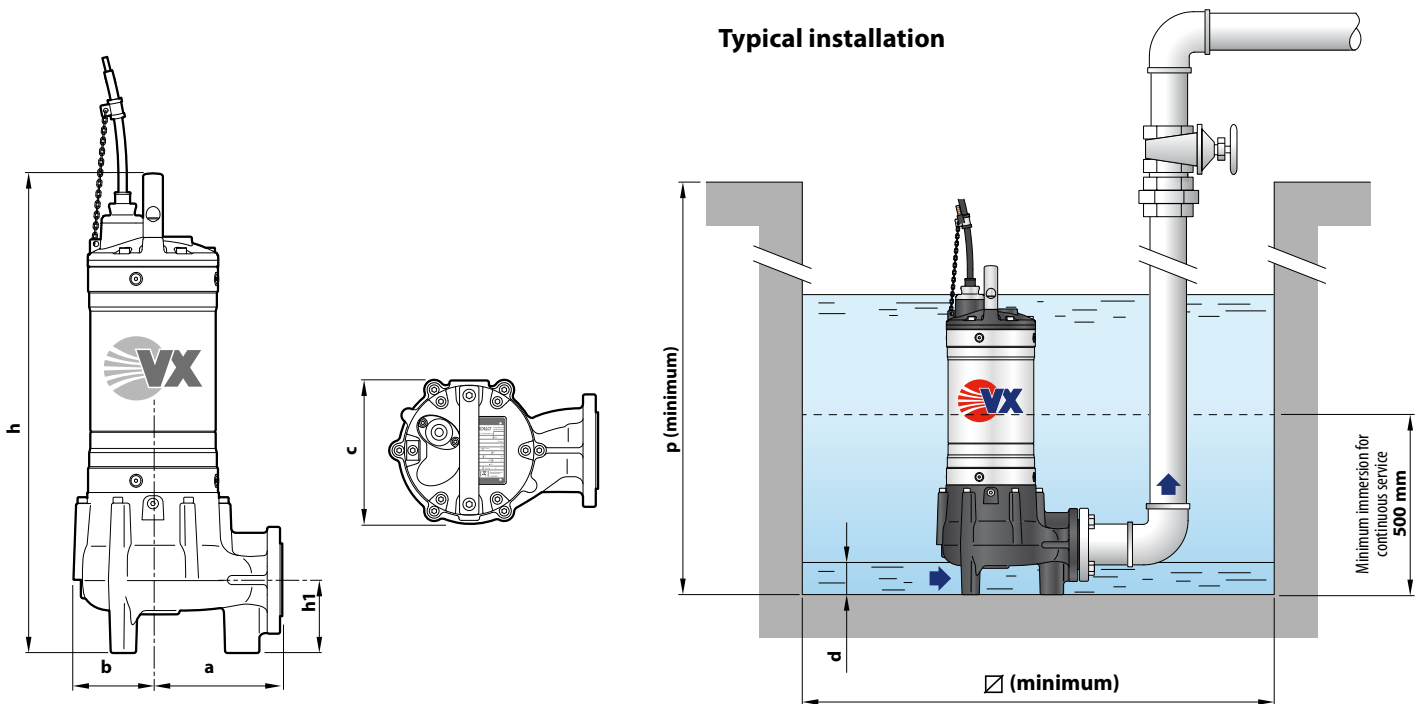

TYPE	Passage of solid bodies	DIMENSIONS mm								kg
		a	b	c	h	h1	d	p	Ø	
Three-phase										3~
VX4-10/50	Ø 50 mm	170	106	193	602	100	55	700	500	47.3
VX4-10/65	Ø 65 mm	170	107	196	630	121	70	800	500	50.6
VX4-10/80	Ø 80 mm	178	107	210	655	150	85	800	500	52.1

PORT FLANGE

TYPE	FLANGE	F	K	D	HOLES	
					N°	Ø (mm)
Three-phase	DN		mm	mm		
VX4-10/50	50 (PN10)	2"	125	150	4	18
VX4-10/65	65 (PN10)	2½"	145	185	8	18
VX4-10/80	80 (PN10)	3"	160	200	8	18

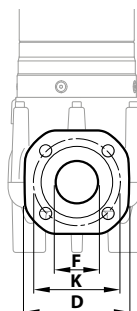

PALLET CAPACITY

TYPE	NO. OF PUMPS
Three-phase	
VX4-10/50	12
VX4-10/65	12
VX4-10/80	12

MATERIALS AND COMPONENTS

1 Pump body Cast iron with cataphoresis treatment

2 Impeller Cast iron VORTEX type with cataphoresis treatment

3 Motor sleeve Stainless steel **AISI 304**

4 Motor cover Cast iron with cataphoresis treatment

5 Motor shaft Stainless steel **AISI 431**

6 Double mechanical seal with interposed oil chamber

Seal	Shaft	Location	Materials
AR-27	Ø 27 mm	Motor side	Silicon carbide / Graphite / NBR
AR-25	Ø 25 mm	Pump side	Silicon carbide/Silicon carbide/NBR

7 Electric Motor

Three-phase 400 V - 50Hz
with winding integrated thermal three-phase motor
protection

- Insulation: class F
- Protection rating: IP X8

8 Power cord

※ 10 metres 'H07 RN-F' type

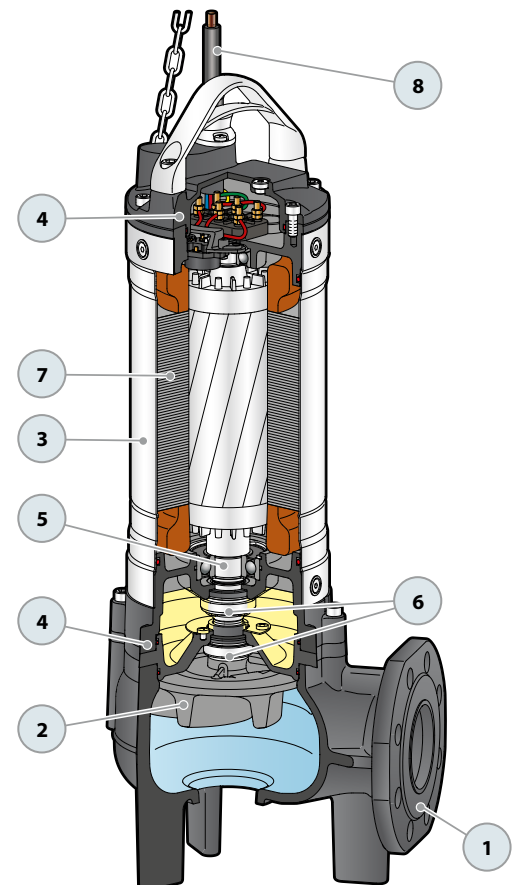



Sewage



Civil use



Industrial use

※ Submersible pumps 4 poles (1450 min⁻¹)



PERFORMANCE RANGE

- Flow rate up to **1200 l/min** (72 m³/h)
- Head up to **6 m**

INSTALLATION AND USE

The **BC4** series is constructed from thick stainless steel and cast iron, offering exceptional robustness, abrasion resistance, and durability. Equipped with a **TWO-CHANNEL** impeller, the pumps are designed to **drain sewage, sludge-mixed water, and activated and putrid sludge**. They are suitable for a wide range of applications, including sewers, tunnels, excavations, canals, and underground parking facilities.

ELECTRIC MOTOR

- ※ **The electric motor is safeguarded by a special three-phase thermal protector, situated within the motor, which activates in case of overheating or abnormal power consumption.**

INCLUDES

- ※ Power cable length **10 m**

APPLICATION LIMITS

- Depth below water level up to **10 m**
(with an appropriately sized power cable)
- Liquid temperature up to **+40 °C**
- Capable of processing suspended solids up to **Ø 50 mm**
- **Minimum immersion for continuous service: 500 mm**

AVAILABLE UPON REQUEST

- ※ Different voltage requirements 60 Hz frequency

PATENTS - TRADE MARKS - MODELS

- Registered Community Model No. 003863158-0001

CURVES AND PERFORMANCE DATA – n= 1450 min⁻¹

50 Hz

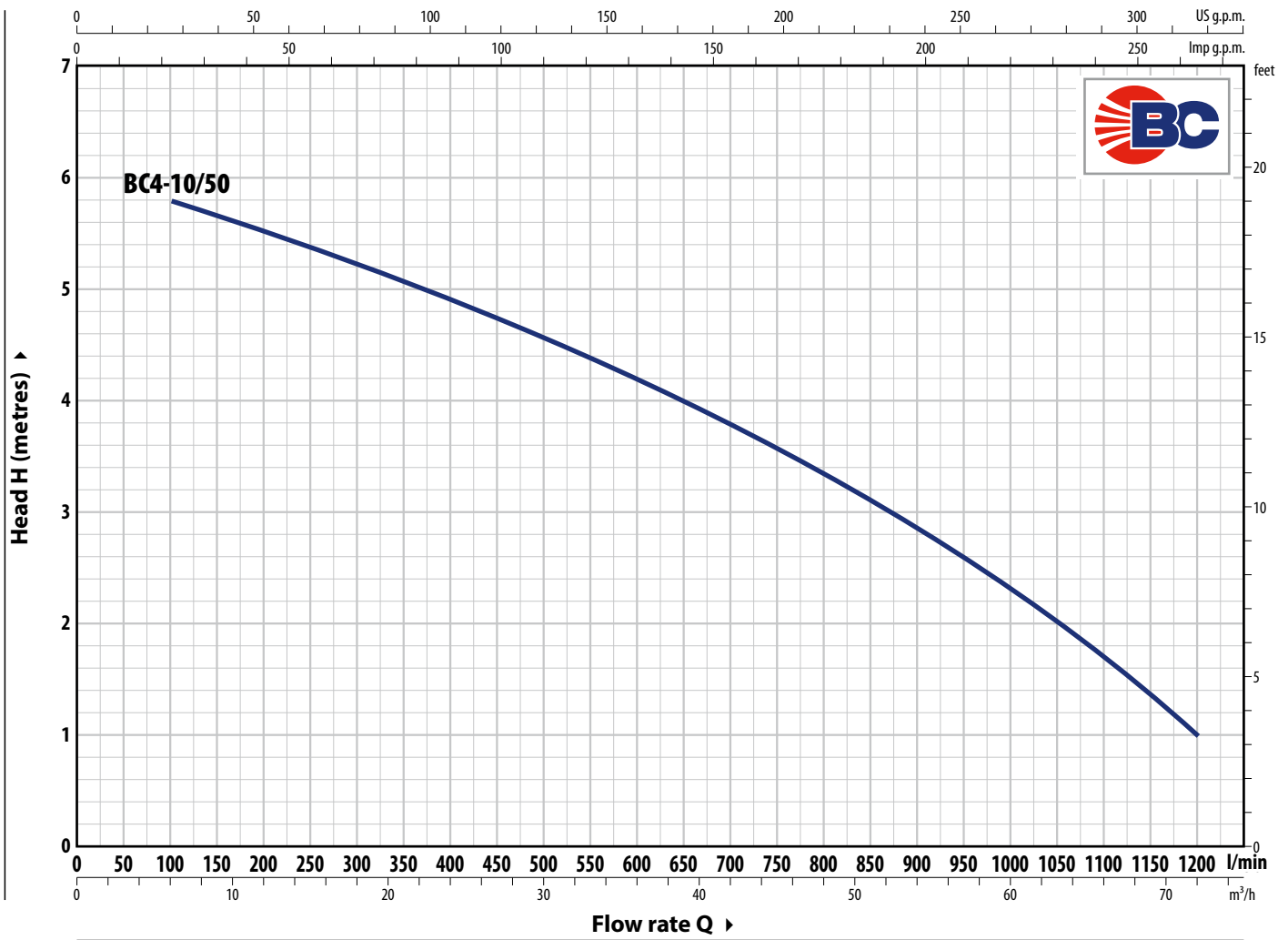

TYPE	POWER (P ₂)		Q	Flow rate												
	kW	HP		m ³ /h	0	6	12	24	30	36	45	54	60	72		
Three-phase			l/min	0	100	200	400	500	600	750	900	1000	1200			
BC4-10/50	0.75	1	H metres	6	6	5.9	5.3	5	4.4	3.6	2.7	2	1			

Q = Flow rate H = Total manometric head

Performance curves comply with EN ISO 9906 Grade 3B tolerance limits.

ABSORPTION

TYPE	VOLTAGE
Three-phase	400 V
BC4-10/50	2.7 A

DIMENSIONS AND WEIGHT

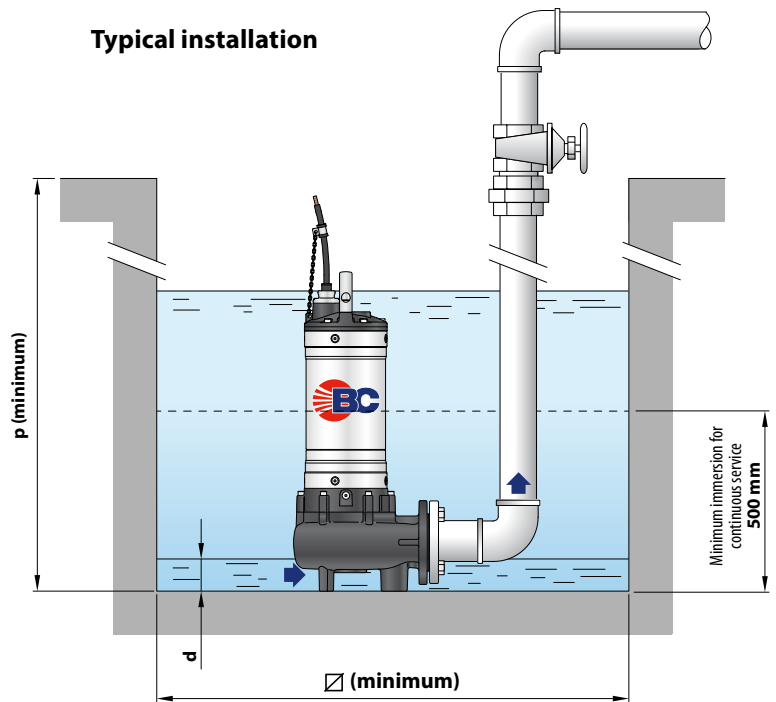
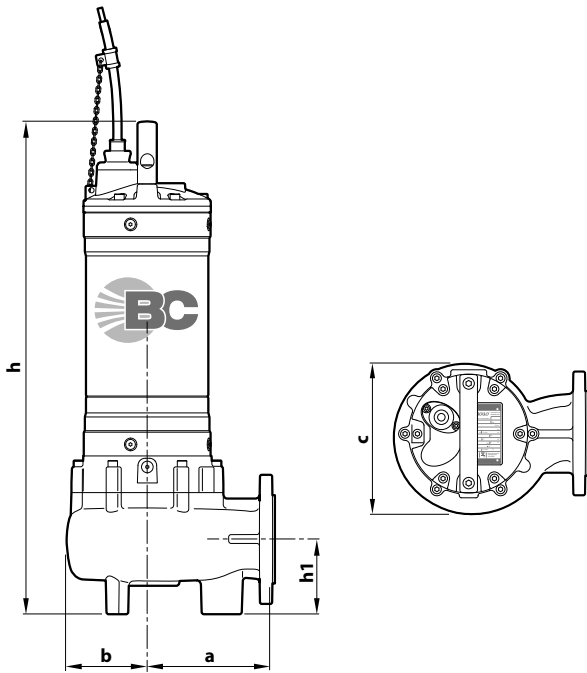

TYPE	Passage of solid bodies	DIMENSIONS mm								3~
		a	b	c	h	h1	d	p	∅	
BC4-10/50	∅ 50 mm	178	107	210	655	150	85	800	500	55.8

PORT FLANGE

TYPE	FLANGE	F	K	D	HOLES	
Three-phase	DN		mm	mm	N°	∅ mm)
BC4-10/50	80 (PN10)	3"	160	200	8	18

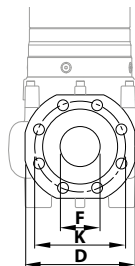

PALLET CAPACITY

TYPE	NO. OF PUMPS
Three-phase	
BC4-10/50	12

MATERIALS AND COMPONENTS

- | | |
|-----------------------|--|
| 1 Pump body | Cast iron with cathoresis treatment |
| 2 Impeller | TWO-CHANNEL cast iron type with cathoresis treatment |
| 3 Motor sleeve | Stainless steel AISI 304 |
| 4 Motor cover | Cast iron with cathoresis treatment |
| 5 Motor shaft | Stainless steel AISI 431 |

6 Double mechanical seal with interposed oil chamber

Seal	Shaft	Location	Materials
AR-27	Ø 27 mm	Motor side	Silicon carbide / Graphite / NBR
AR-25	Ø 25 mm	Pump side	Silicon carbide/Silicon carbide/NBR

7 Electric Motor

Three-phase 400 V - 50Hz
with winding integrated thermal three-phase motor protection

- Insulation: class F
- Protection rating: IP X8

8 Power cord

※ 10 metres 'H07 RN-F' type

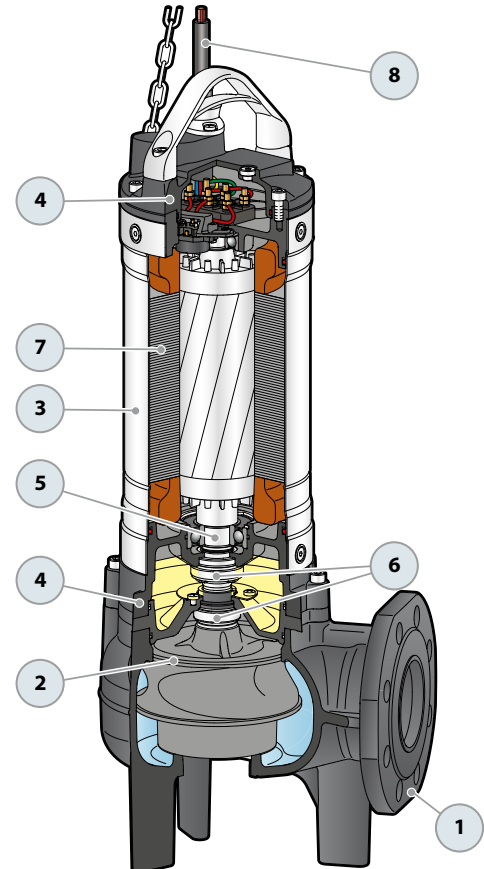

SEWAGE LIFTING SYSTEM VX4 - BC4

VERSION WITH HORIZONTAL DELIVERY AND 3/4" GUIDE PIPES

For VX4 /50	Code ASSPVX50	DN 2
--------------------	---------------	-------------

※ Kit consisting of:



Coupling foot



Guide rail



Support for guide tubes



VERSION WITH VERTICAL DELIVERY AND 3/4" GUIDE PIPES

For VX4 /50	Code ASSPVX503V	DN 2 1/2"
For VX4 /65	Code ASSPVX653V	DN 3"
For BC4 /50	Code ASSVXCF071V	

VERSION WITH VERTICAL DELIVERY AND 2" GUIDE TUBES

For VX4 /50	Code ASSPVX50V	DN 3"
For VX4 /65	Code ASSPVX65V	
For VX4 /80, BC4 /50	Code ASSVXCF0705V	

※ Kit consisting of:



Coupling foot complete with counterflange



Guide rail



Support for guide tubes



● ACCESSORIES AVAILABLE FOR ORDER

RUNNING GUIDE

※ For VX4 /50 with Ø 3/4" guide tubes	Code ASSFL009
※ For VX4 /65 with Ø 3/4" guide tubes	Code ASSFL010
※ For BC4 /50 with Ø 3/4" guide tubes	Code ASSFL0018
※ For VX4 /50 with Ø 2" guide tubes	Code ASSFL050
※ For VX4 /65 with Ø 2" guide tubes	Code ASSFL065
※ For VX4 /80, BC4 /50 with Ø 2" guide tubes	Code ASSFL072

Complete with screws and seals



for Ø 3/4" guide tubes



for guide tubes Ø 2"

INTERMEDIATE GUIDE TUBE SUPPORT

※ For Ø 3/4" guide tubes	Code 859SV340INTFA
※ For guide tubes Ø 2"	Code 859SV349INTFA

For reasons of stability, an intermediate support should be interposed:

- every 2 metres with 3/4" guide pipes (mandatory)
- every 3 metres with 2" guide tubes (recommended)



for Ø 3/4" guide tubes



for guide tubes Ø 2"

GUIDE TUBE (AISI 304 stainless steel)

※ 2 metres Ø 3/4" guide tube	Code 54SARTG0052F
※ 3 metres Ø 3/4" guide tube	Code 54SARTG0053F
※ 6 metres Ø 3/4" guide tube	Code 54SARTG0056F
※ 3 metres Ø 2" guide tube	Code 54SARTG0063F
※ 6 metres guide tube Ø 2"	Code 54SARTG0066F



DIMENSIONS (HORIZONTAL delivery version)

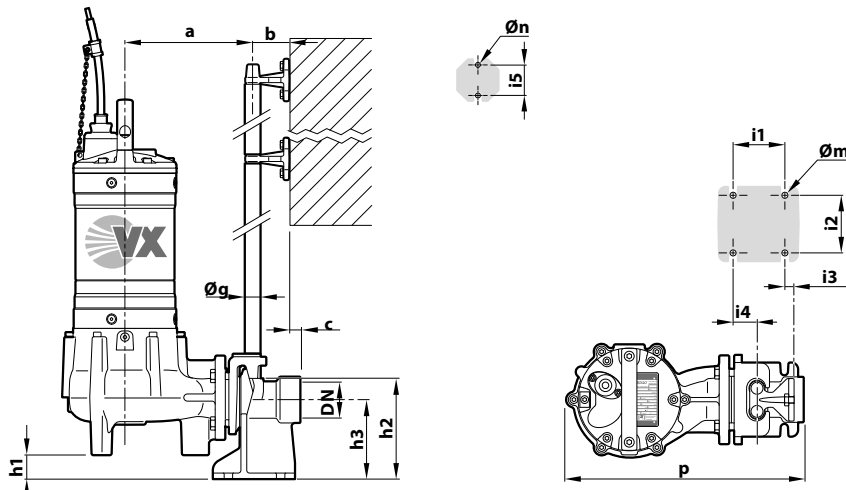

TYPE	Solid bodies mm	PORT DN	DIMENSIONS mm														
			a	b	c	p	h1	h2	h3	i1	i2	i3	i4	i5	Øg	Øm	Øn
VX4 /50	Ø 50	2"	214	61	17	400	30	165	130	85	94	16	40	50	¾"	12	11

DIMENSIONS (Version with VERTICAL delivery)

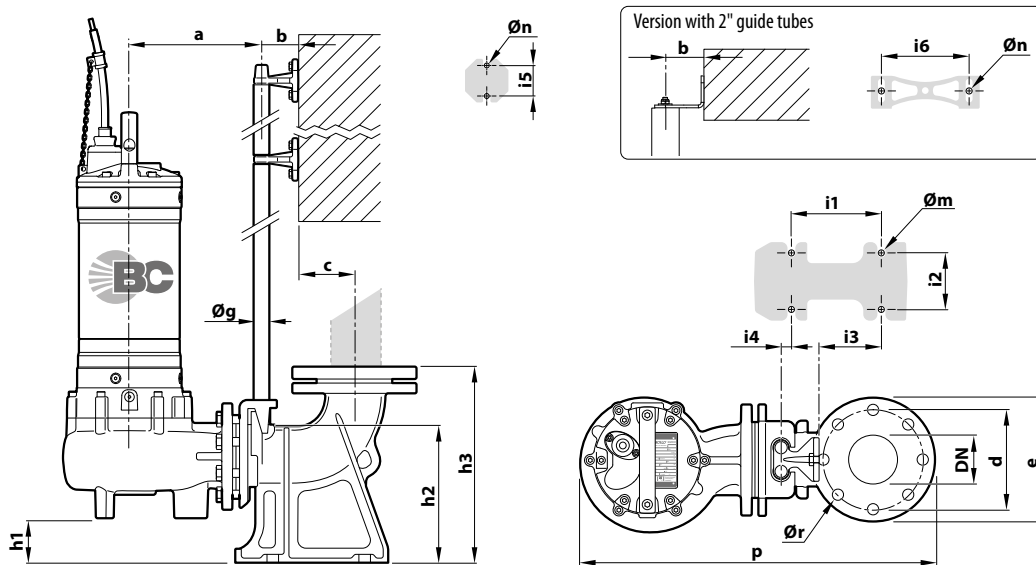

※ Version with ¾" guide tubes

TYPE	Solid bodies mm	PORT DN	DIMENSIONS mm																	
			a	b	c	d	e	p	h1	h2	h3	i1	i2	i3	i4	i5	Øg	Øm	Øn	Ør
VX4 /50	Ø 50 mm	2½"	211		52	125	165	506	28	164	216	120	72	62	3					
VX4 /65	Ø 65 mm	3"	213	61	69	150	190	537	48	216	280	130	112	84	15	50	¾"	14	11	18
BC4 /50	Ø 50 mm		222					553	19											

※ Version with 2" guide tubes

TYPE	Solid bodies mm	PORT DN	DIMENSIONS mm																			
			a	b	c	d	e	p	h1	h2	h3	i1	i2	i3	i4	i5	i6	Øg	Øm	Øn	Ør	
VX4 /50	Ø 50 mm	3"						706	107													
VX4 /65	Ø 65 mm		319					697	86													
VX4 /80	Ø 80 mm		328	86	95	160	200	714	57	264	392	250	150	34	-	80	186	2"	22	13.5	18	
BC4 /50	Ø 50 mm		328					714	57													



Sewage



Civil use



Industrial use

※ Submersible pumps 4 poles (1450 min⁻¹)



PERFORMANCE RANGE

- Flow rate up to **2200 l/min** (132 m³/h)
- Head up to **12.2 m**

INSTALLATION AND USE

The **VXC4** series is constructed from thick stainless steel and cast iron, offering exceptional robustness, abrasion resistance, and durability. Equipped with a **VORTEX**-type impeller, the pumps are designed to **drain sewage, sludge-mixed water, and activated and putrid sludge**.

They are suitable for a wide range of applications, including sewers, tunnels, excavations, canals, and underground parking facilities.

ELECTRIC MOTOR

- ※ **The electric motor is safeguarded by a special three-phase thermal protector, situated within the motor, which activates in case of overheating or abnormal power consumption.**

INCLUDES

- ※ Power cable length **10 m**

APPLICATION LIMITS

- Depth below water level up to **10 m** (with an appropriately sized power cable)
- Liquid temperature up to **+40 °C**
- Capable of processing suspended solids up to **Ø 100 mm**
- **Minimum immersion for continuous service: 550 mm**

AVAILABLE UPON REQUEST

- ※ Pumps equipped with internal probes that detect the presence of water in the oil chamber
- ※ Different voltage requirements 60 Hz frequency

PATENTS - TRADE MARKS - MODELS

- Registered Community Model No. 003863158-0003

CURVES AND PERFORMANCE DATA – n= 1450 min⁻¹

50 Hz

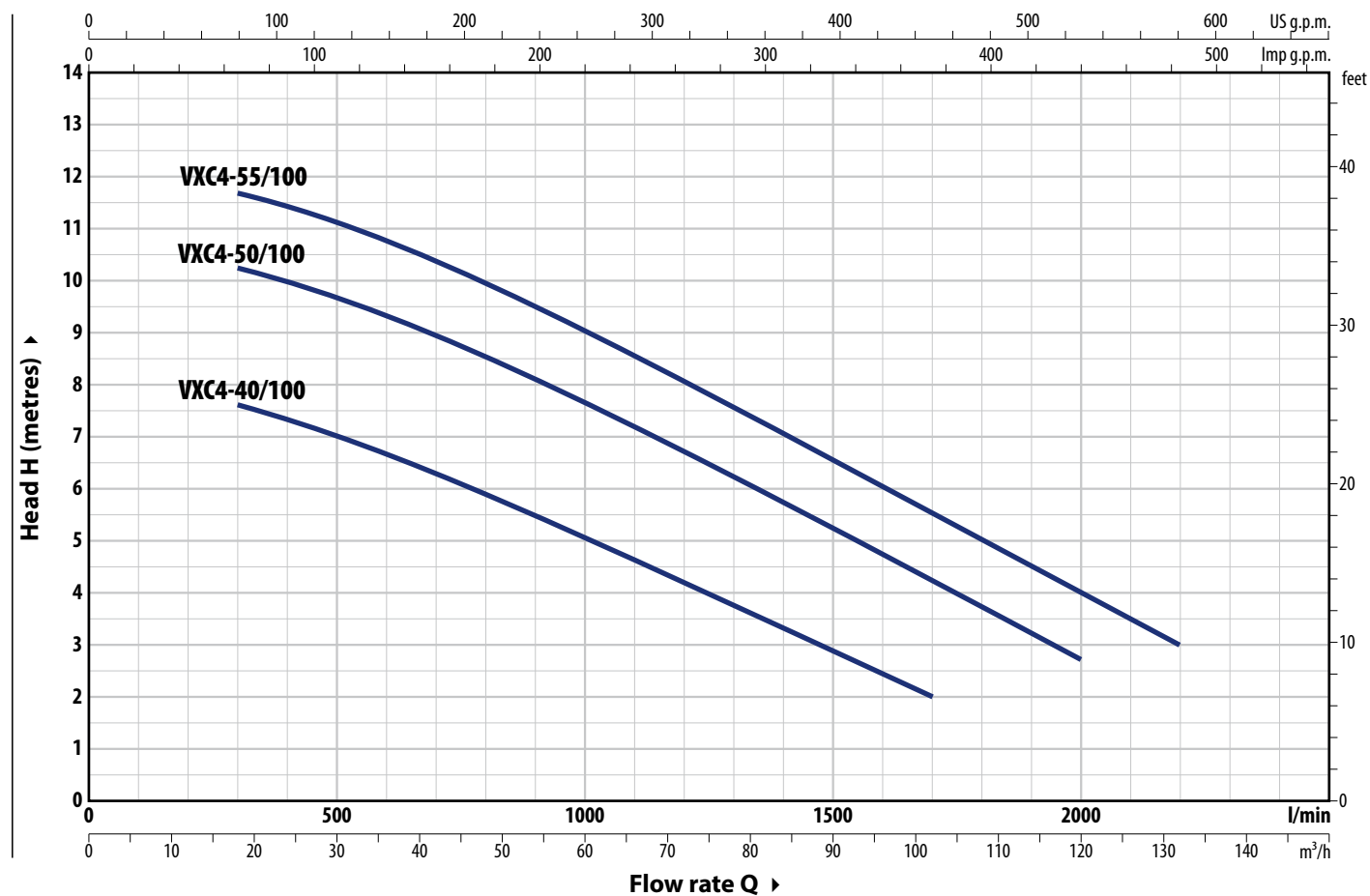

TYPE Three-phase	POWER (P ₂)		Q	0	18	30	45	60	75	90	102	120	132
	kW	HP		0	300	500	750	1000	1250	1500	1700	2000	2200
VXC4-40/100	3	4	H metres	8.3	7.6	7	6	5	4	3	2		
VXC4-50/100	3.7	5		10.8	10.2	9.6	8.7	7.6	6.4	5.2	4.2	2.7	
VXC4-55/100	4	5.5		12.2	11.7	11	10.2	9	7.8	6.5	5.5	4	3

Q = Flow rate H = Total manometric head

Performance curves comply with EN ISO 9906 Grade 3B tolerance limits.

ABSORPTION

TYPE Three-phase	VOLTAGE 400 V
VXC4-40/100	5.5 A
VXC4-50/100	7.7 A
VXC4-55/100	9.0 A

DIMENSIONS AND WEIGHT

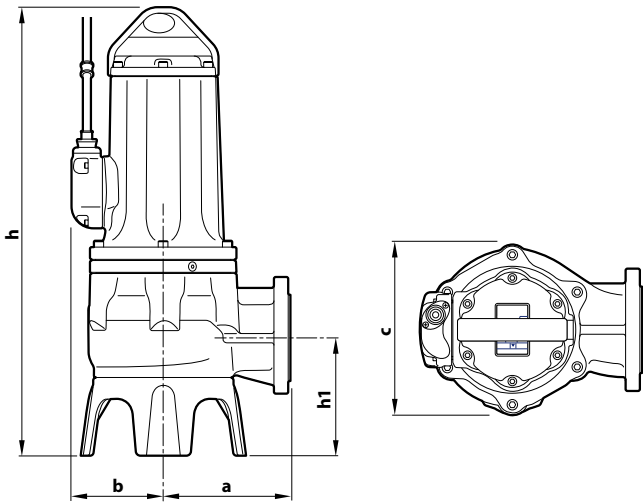

Typical installation

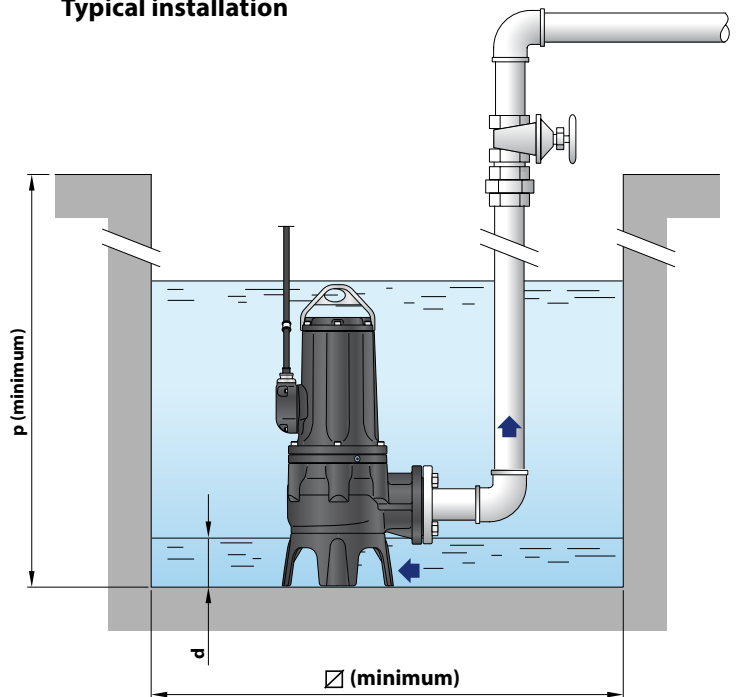

TYPE	Passage of solid bodies	DIMENSIONS mm								kg 3~
		a	b	c	h	h1	d	p	Ø	
Three-phase	Ø 100 mm	228	165	302	806	211	140	1000	1000	129.1
VXC4-40/100										129.0
VXC4-50/100										132.0
VXC4-55/100										

PORT FLANGE

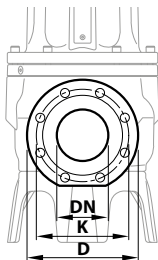

TYPE	FLANGE DN	K mm	D mm	HOLES	
				N°	Ø (mm)
Three-phase	100 (PN10)	180	220	8	18
VXC4-40/100					
VXC4-50/100					
VXC4-55/100					

COUNTERFLANGE

(CAN BE ORDERED SEPARATELY)

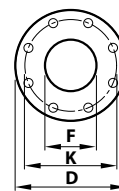

TYPE	FLANGE DN	F mm	K mm	D mm	HOLES	
					N°	Ø (mm)
Three-phase	100	4"	180	220	8	18
VXC4-40/100						
VXC4-50/100						
VXC4-55/100						

PALLET CAPACITY

TYPE	NO. OF PUMPS
Three-phase	
VXC4-40/100	4
VXC4-50/100	4
VXC4-55/100	4

MATERIALS AND COMPONENTS

1 Pump body Cast iron with cathoresis treatment

2 Base Cast iron with cathoresis treatment

3 Impeller Cast iron VORTEX type with cathoresis treatment

4 Motor holder Cast iron with cathoresis treatment

5 Motor cover Cast iron with cathoresis treatment

6 Motor shaft Stainless steel **AISI 431**

7 Double mechanical seal with interposed oil chamber

Seal	Shaft	Location	Materials
MG91-40D	Ø 40 mm	Motor side	Silicon carbide / Graphite / NBR
		Pump side	Silicon carbide/Silicon carbide/NBR

8 Electric motor

Three-phase 400 V - 50Hz
with winding integrated thermal motor protection

- Insulation: class F
- Protection rating: IP X8

9 Power cord

※ 10 metres 'H07 RN-F' type

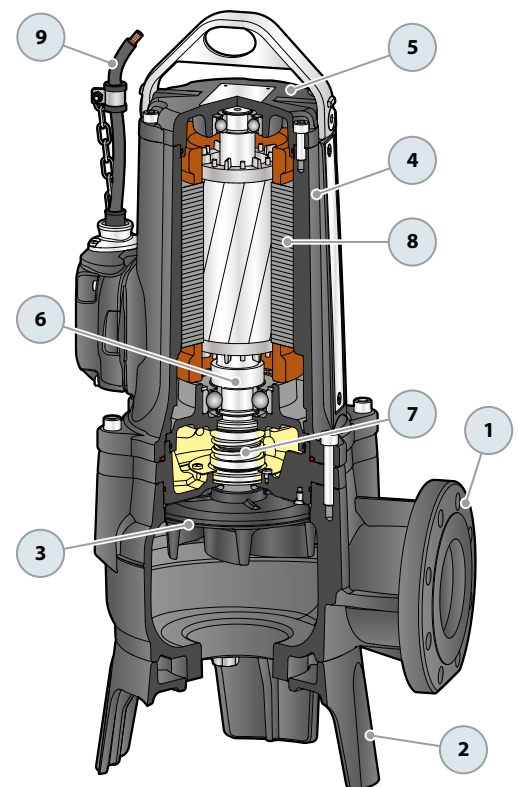

-  Sewage
-  Civil use
-  Industrial use

※ Submersible pumps 4 poles (1450 min⁻¹)



PERFORMANCE RANGE

- Flow rate up to **2900 l/min** (174 m³/h)
- Head up to **16 m**

INSTALLATION AND USE

The **MC4** series is constructed from thick stainless steel and cast iron, offering exceptional robustness, abrasion resistance, and durability. Equipped with a **TWO-CHANNEL** impeller, the pumps are designed to **drain liquids containing suspended solids and short fibers, as well as sewage**, sludge-mixed water, groundwater, and surface water.

They are suitable for a wide range of applications, including apartment buildings, public facilities, industries, parking facilities, washing areas.

ELECTRIC MOTOR

- ※ **The electric motor is safeguarded by a special three-phase thermal protector, situated within the motor, which activates in case of overheating or abnormal power consumption.**

INCLUDES

- ※ Power cable length **10 m**

APPLICATION LIMITS

- Depth below water level up to **10 m** (with an appropriately sized power cable)
- Liquid temperature up to **+40 °C**
- Capable of processing suspended solids up to **Ø 55 mm**
- **Minimum immersion for continuous service: 550 mm**

AVAILABLE UPON REQUEST

- ※ Pumps equipped with internal probes that detect the presence of water in the oil chamber

PATENTS - TRADE MARKS - MODELS

- Registered Community Model No. 003863158-0004

CURVES AND PERFORMANCE DATA – n= 1450 min⁻¹

50 Hz

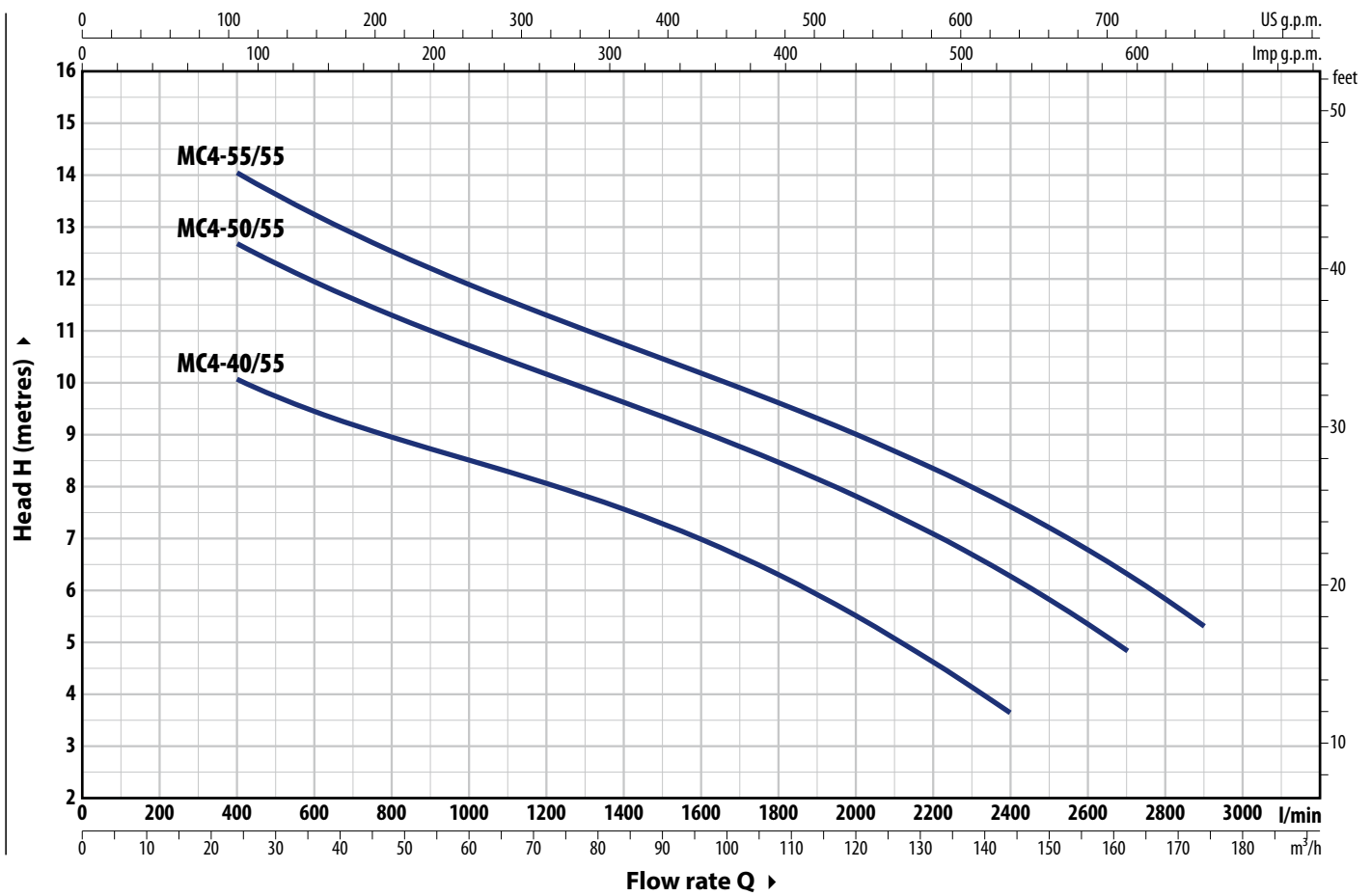

TYPE Three-phase	POWER (P ₂)		Q	Flow rate													
	kW	HP		m ³ /h	0	24	48	72	96	108	120	132	144	162	174		
MC4-40/55	3	4	H metres	0	400	800	1200	1600	1800	2000	2200	2400	2700	2900			
MC4-50/55	3.7	5		12	10	9	8	7	6.3	5.5	4.6	3.6					
MC4-55/55	4	5.5		14.5	12.6	11.3	10	9	8.4	7.8	7	6.2	4.8				
				16	14	12.5	11.3	10.2	9.6	9	8.3	7.6	6.3	5.3			

Q = Flow rate H = Total manometric head

Performance curves comply with EN ISO 9906 Grade 3B tolerance limits.

ABSORPTION

TYPE Three-phase	VOLTAGE 400 V
MC4-40/55	5.5 A
MC4-50/55	7.7 A
MC4-55/55	8.3 A

DIMENSIONS AND WEIGHT

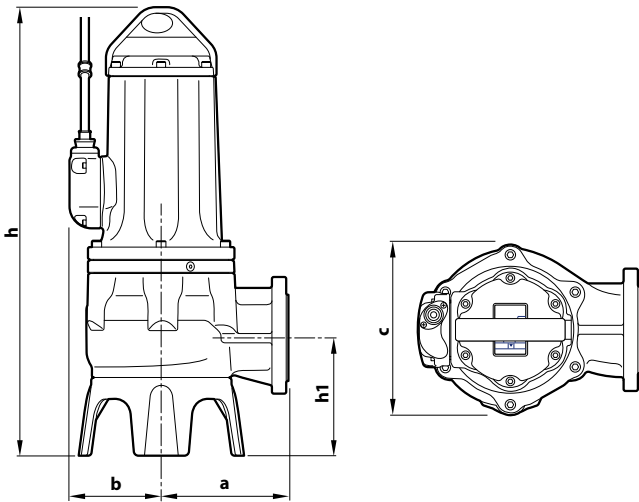

Typical installation

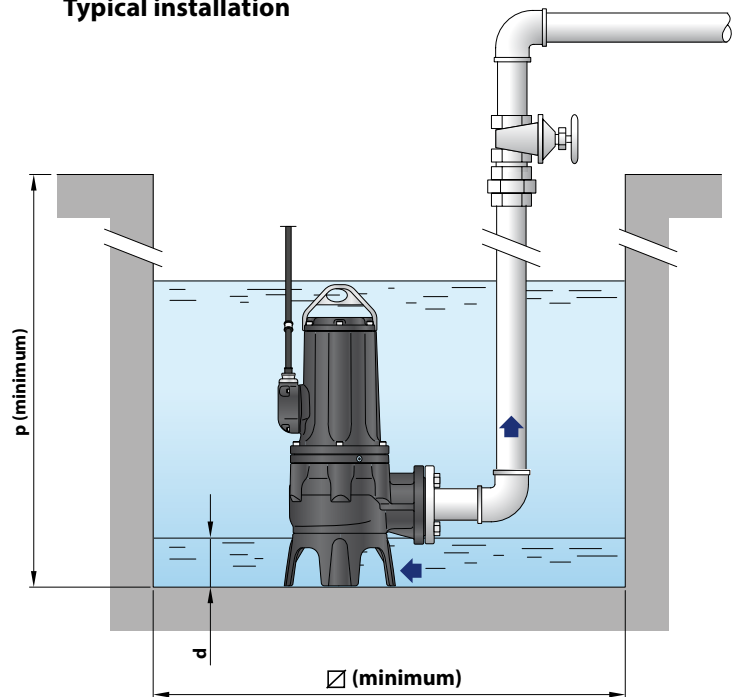

TYPE	Passage of solid bodies	DIMENSIONS mm								kg
		a	b	c	h	h1	d	p	Ø	
Three-phase	Ø 55 mm	248	165	320	792	228	140	1000	1000	3~
MC4-40/55										125.2
MC4-50/55										133.0
MC4-55/55										136.0

PORT FLANGE

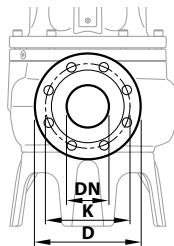

COUNTERFLANGE

(CAN BE ORDERED SEPARATELY)

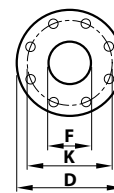

TYPE	FLANGE	K	D	HOLES	
Three-phase	DN	mm	mm	N°	Ø (mm)
MC4-40/55	80 (PN10)	160	200	8	18
MC4-50/55					
MC4-55/55					

TYPE	FLANGE	F	K	D	HOLES	
Three-phase	DN	mm	mm	mm	N°	Ø (mm)
MC4-40/55	80	3"	160	200	8	18
MC4-50/55						
MC4-55/55						

PALLET CAPACITY

TYPE	NO. OF PUMPS
Three-phase	
MC4-40/55	4
MC4-50/55	4
MC4-55/55	4

MATERIALS AND COMPONENTS

1 Pump body Cast iron with cathoresis treatment

2 Base Cast iron with cathoresis treatment

3 Impeller TWO-CHANNEL cast iron type with cathoresis treatment

4 Motor holder Cast iron with cathoresis treatment

5 Motor cover Cast iron with cathoresis treatment

6 Motor shaft Stainless steel **AISI 431**

7 Double mechanical seal with interposed oil chamber

Seal	Shaft	Location	Materials
MG91-40D	Ø 40 mm	Motor side Pump side	Silicon carbide / Graphite / NBR Silicon carbide/Silicon carbide/NBR

8 Electric motor

Three-phase 400 V - 50Hz
with winding integrated thermal motor protection

- Insulation: class F
- Protection rating: IP X8

9 Power cord

※ 10 metres 'H07 RN-F' type

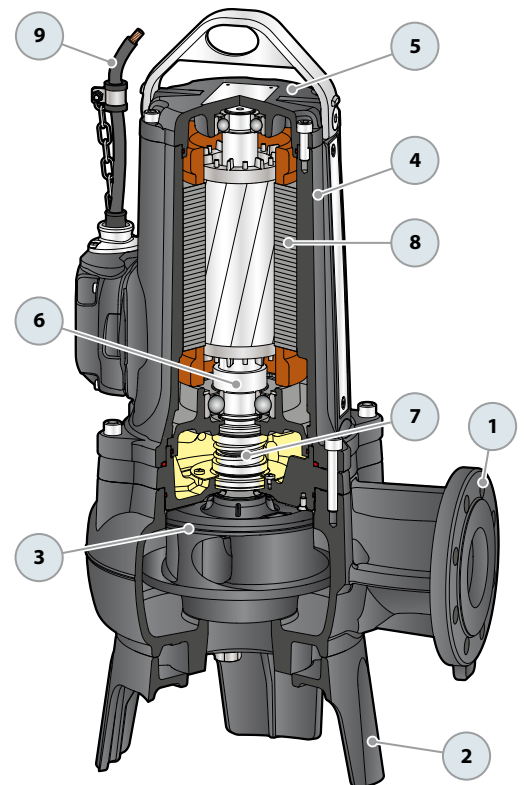

SEWAGE LIFTING SYSTEM VXC4 - MC4

VERSION WITH VERTICAL DELIVERY AND 2" GUIDE TUBES

For VXC4	Code ASSPVXC4V	DN 4"
For MC4	Code ASSPMC4V	DN 3"

※ **Kit consisting of:**



Coupling foot complete with counterflange



Slide rail with screws and gasket



Support for guide tubes



ACCESSORIES AVAILABLE FOR ORDER

RUNNING GUIDE

※ For VXC4	Code ASSFL100
※ For MC4	Code ASSFL080

Complete with screws and seals

INTERMEDIATE GUIDE TUBE SUPPORT

※ For guide tubes Ø 2"	Code 859SV349INTFA
------------------------	--------------------

For reasons of stability, interpose a support every 3 metres (recommended)

GUIDE TUBE (AISI 304 stainless steel)

※ 3 metres Ø 2" guide tube	Code 54SARTG0063F
※ 6 metres guide tube Ø 2"	Code 54SARTG0066F



Typical installation

1. Water pump
2. Pump Base
3. Guide Rails
4. Upper Guide Rail Support
5. Intermediate Guide Rail Support
6. Lifting chain
7. Control Panel
8. Stop Float Switch
9. Start Float Switch
10. Supplementary pump start float switch
11. Alarm float
12. Check val

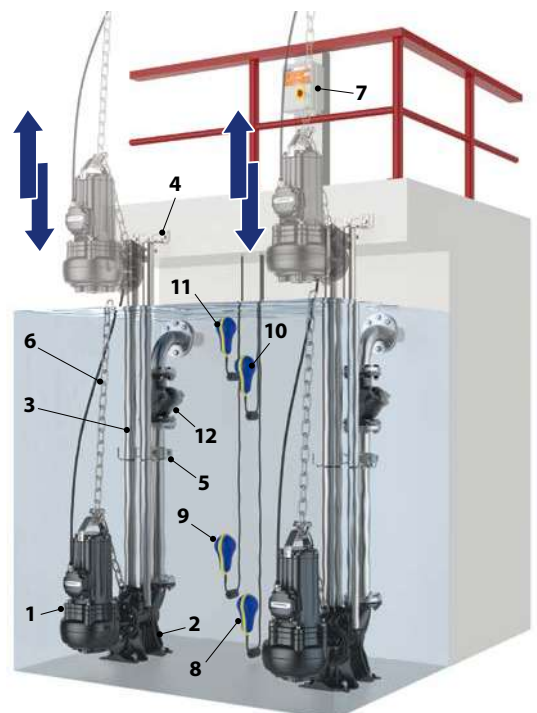

DIMENSIONS

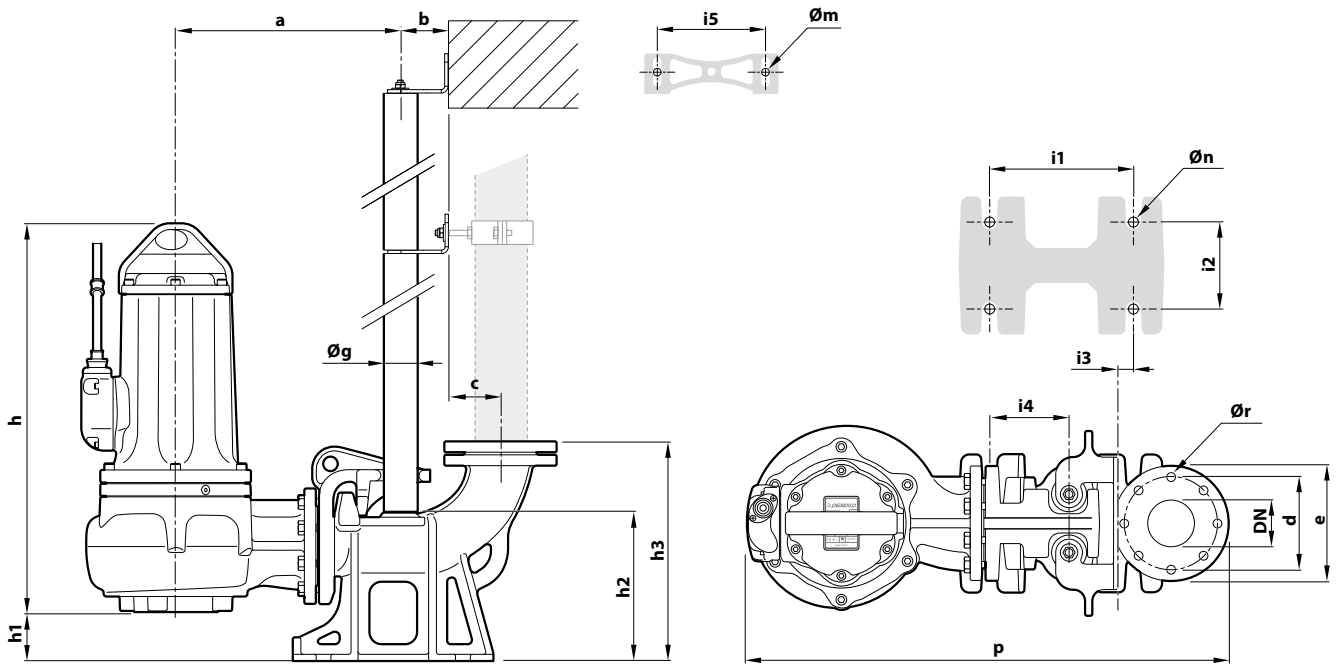

TYPE	Passage of solid bodies mm	PORT DN	DIMENSIONS mm																			
			a	b	c	d	e	p	h	h1	h2	h3	i1	i2	i3	i4	i5	Øg	Øm	Øn	Ør	
Three-phase																						
VXC4-40/100	Ø 100 mm	4"	376	85	105	180	220	841	695	107	266	426	250	150	34	130	186	2"	13	16	18	
VXC4-50/100																						
VXC4-55/100																						

TYPE	Passage of solid bodies mm	PORT DN	DIMENSIONS mm																				
			a	b	c	d	e	p	h	h1	h2	h3	i1	i2	i3	i4	i5	Øg	Øm	Øn	Ør		
Three-phase																							
MC4-40/55	Ø 55 mm	3"	396	85	95	160	200	841	680	92	256	592	250	150	34	130	186	2"	13	16	18		
MC4-50/55																							
MC4-55/55																							



Sewage



Civil use



Industrial use

※ Submersible pumps 4 poles (1450 min⁻¹)



PERFORMANCE RANGE

- Flow rate up to **5000 l/min** (300 m³/h)
- Head up to **22.5 m**

INSTALLATION AND USE

The **VXC4** series is constructed from thick stainless steel and cast iron, offering exceptional robustness, abrasion resistance, and durability. Equipped with a **VORTEX**-type impeller, the pumps are designed to **drain sewage, sludge-mixed water, and activated and putrid sludge**.

They are suitable for a wide range of applications, including sewers, tunnels, excavations, canals, and underground parking facilities.

ELECTRIC MOTOR

※ **Electric motor with built-in three-phase thermal protection in the winding must be connected to the electrical panel.**

N.B. The warranty is valid if the thermal protection is connected to the electrical panel.

INCLUDES

- ※ Power cable length **10 m**

APPLICATION LIMITS

- Depth below water level up to **10 m** (with an appropriately sized power cable)
- Liquid temperature up to **+40 °C**
- Capable of processing suspended solids up to **Ø 80 mm**
- **For continuous service, the pump must not rise more than 290 mm**

AVAILABLE UPON REQUEST

- ※ Pumps equipped with internal probes that detect the presence of water in the oil chamber
- ※ Pumps with double cable for star/delta starting
- ※ Different voltage requirements 60 Hz frequency

CURVES AND PERFORMANCE DATA – n= 1450 min⁻¹

50 Hz

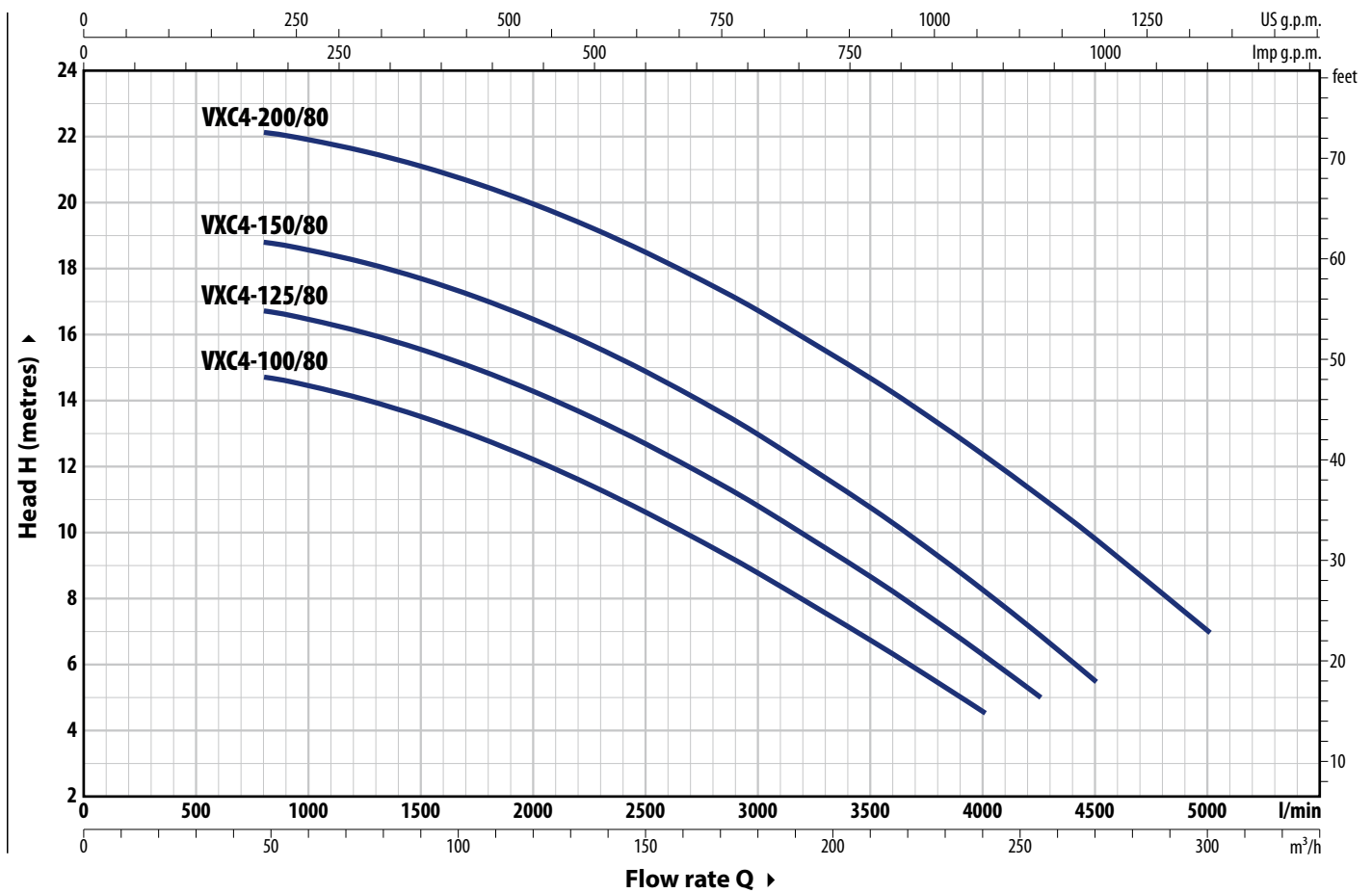

TYPE	POWER (P ₂)		Q	Flow rate														
	kW	HP		m ³ /h	0	48	60	90	120	150	180	210	240	255	270	300		
Three-phase			l/min	0	800	1000	1500	2000	2500	3000	3500	4000	4250	4500	5000			
VXC4-100/80	7.5	10	H metres	15	14.7	14.5	13.5	12.2	10.6	8.7	6.7	4.5						
VXC4-125/80	9.2	12.5		17	16.7	16.5	15.5	14.3	12.7	10.8	8.6	6.3	5					
VXC4-150/80	11	15		19	18.8	18.6	17.7	16.4	15	13	10.7	8.2	7	5.5				
VXC4-200/80	15	20		22.5	22.1	22	21	20	18.5	16.7	14.7	12.3	11	9.8	7			

Q = Flow rate H = Total manometric head

Performance curves comply with EN ISO 9906 Grade 3B tolerance limits.

ABSORPTION

TYPE	TENSIONE			
	230 V - Δ	400 V - 人	400 V - Δ	690 V - 人
VXC4-100/80	32.9 A	19.0 A	19.0 A	11.0 A
VXC4-125/80	36.3 A	21.0 A	21.0 A	12.1 A
VXC4-150/80	40.7 A	23.5 A	23.5 A	13.6 A
VXC4-200/80	49.3 A	28.5 A	28.5 A	16.5 A

DIMENSIONS AND WEIGHT

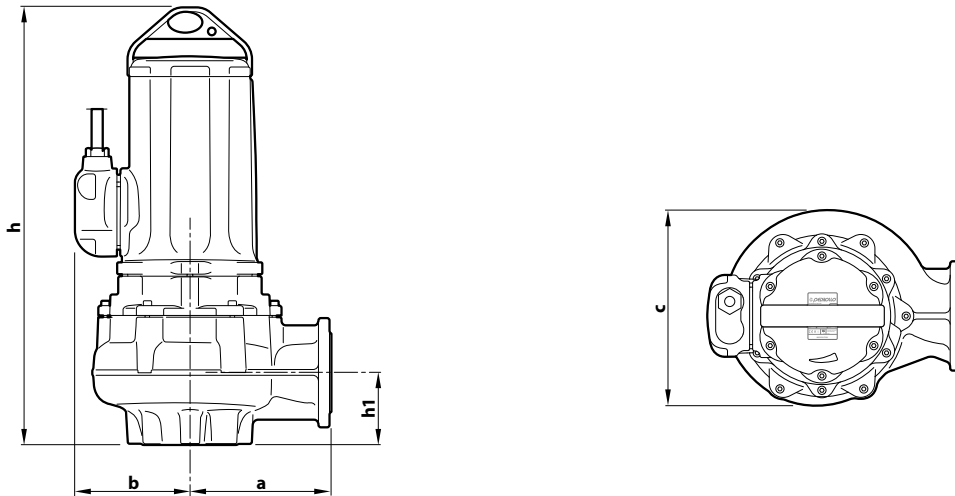

TYPE	Passage of solid bodies	DIMENSIONS mm					kg
		a	b	c	h	h1	
Three-phase	Ø 80 mm	285	228	395	858	130	3~
VXC4-100/80							215
VXC4-125/80							217
VXC4-150/80							227
VXC4-200/80							237

PORT FLANGE

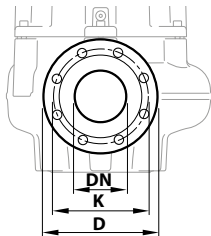

TYPE	FLANGE DN	K mm	D mm	HOLES	
				N°	Ø (mm)
Three-phase	100 (PN10)	180	220	8	18
VXC4-100/80					
VXC4-125/80					
VXC4-150/80					
VXC4-200/80					

COUNTERFLANGE

(CAN BE ORDERED SEPARATELY)

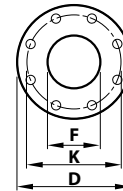

TYPE	FLANGE DN	F mm	K mm	D mm	HOLES	
					N°	Ø (mm)
Three-phase	100	4"	180	220	8	18
VXC4-100/80						
VXC4-125/80						
VXC4-150/80						
VXC4-200/80						

BASE

(CAN BE ORDERED SEPARATELY)

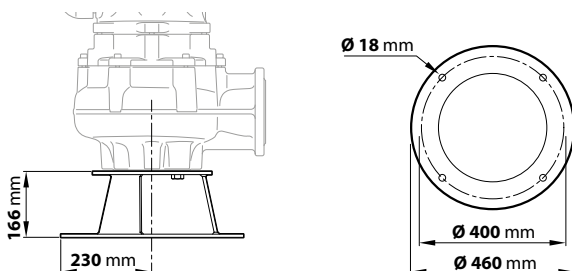

MATERIALS AND COMPONENTS

1 Pump body	Cast iron with cataphoresis treatment
2 Impeller	Cast iron VORTEX type with cataphoresis treatment
3 Motor holder	Cast iron
4 Motor cover	Cast iron
5 Motor shaft	Stainless steel AISI 431

6 Double mechanical seal with interposed oil chamber

Seal	Shaft	Location	Materials
MG1-43	Ø 43 mm	Motor side	Ceramic / Graphite / NBR
ARP-40	Ø 40 mm	Pump side	Silicon carbide/Silicon carbide/NBR

7 Electric Motor

Three-phase 230/400 V - 50 Hz or 400/690 V - 50 Hz
with winding integrated thermal three-phase motor protection to be connected to the switchboard

- Insulation: class F
- Protection rating: IP X8

8 ✖ Probe for detecting water in the oil chamber

9 Power cord

✖ 10 metres 'EM2 quality' type

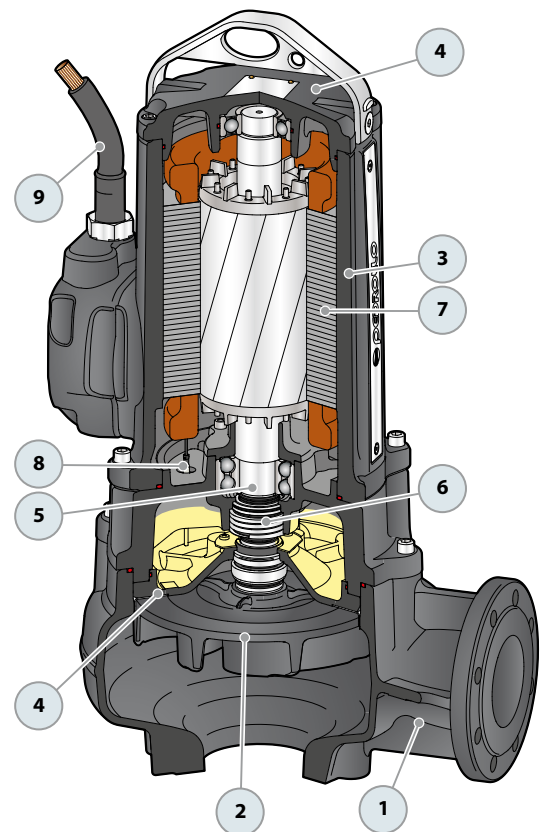



Sewage



Civil use



Industrial use

※ Submersible pumps 4 poles (1450 min⁻¹)



PERFORMANCE RANGE

- Flow rate up to **5000 l/min** (300 m³/h)
- Head up to **28 m**

INSTALLATION AND USE

The **MC4** series is constructed from thick stainless steel and cast iron, offering exceptional robustness, abrasion resistance, and durability.

Equipped with a **TWO-CHANNEL** impeller, the pumps are designed to drain liquids containing suspended solids and short fibers, as well as **sewage, sludge-mixed water, groundwater, and surface water**. They are suitable for a wide range of applications, including apartment buildings, public facilities, industries, parking facilities, washing areas.

ELECTRIC MOTOR

- ※ **Electric motor with built-in three-phase thermal protection in the winding must be connected to the electrical panel.**

N.B. The warranty is valid if the thermal protection is connected to the electrical panel.

INCLUDES

- ※ Power cable length **10 m**

APPLICATION LIMITS

- Depth below water level up to **10 m** (with an appropriately sized power cable)
- Liquid temperature up to **+40 °C**
- Capable of processing suspended solids up to **Ø 80 mm**
- **For continuous service, the pump must not rise more than 290 mm**

AVAILABLE UPON REQUEST

- ※ Pumps equipped with internal probes that detect the presence of water in the oil chamber
- ※ Pumps with double cable for star/delta starting
- ※ Different voltage requirements 60 Hz frequency

CURVES AND PERFORMANCE DATA - n= 1450 min⁻¹

50 Hz

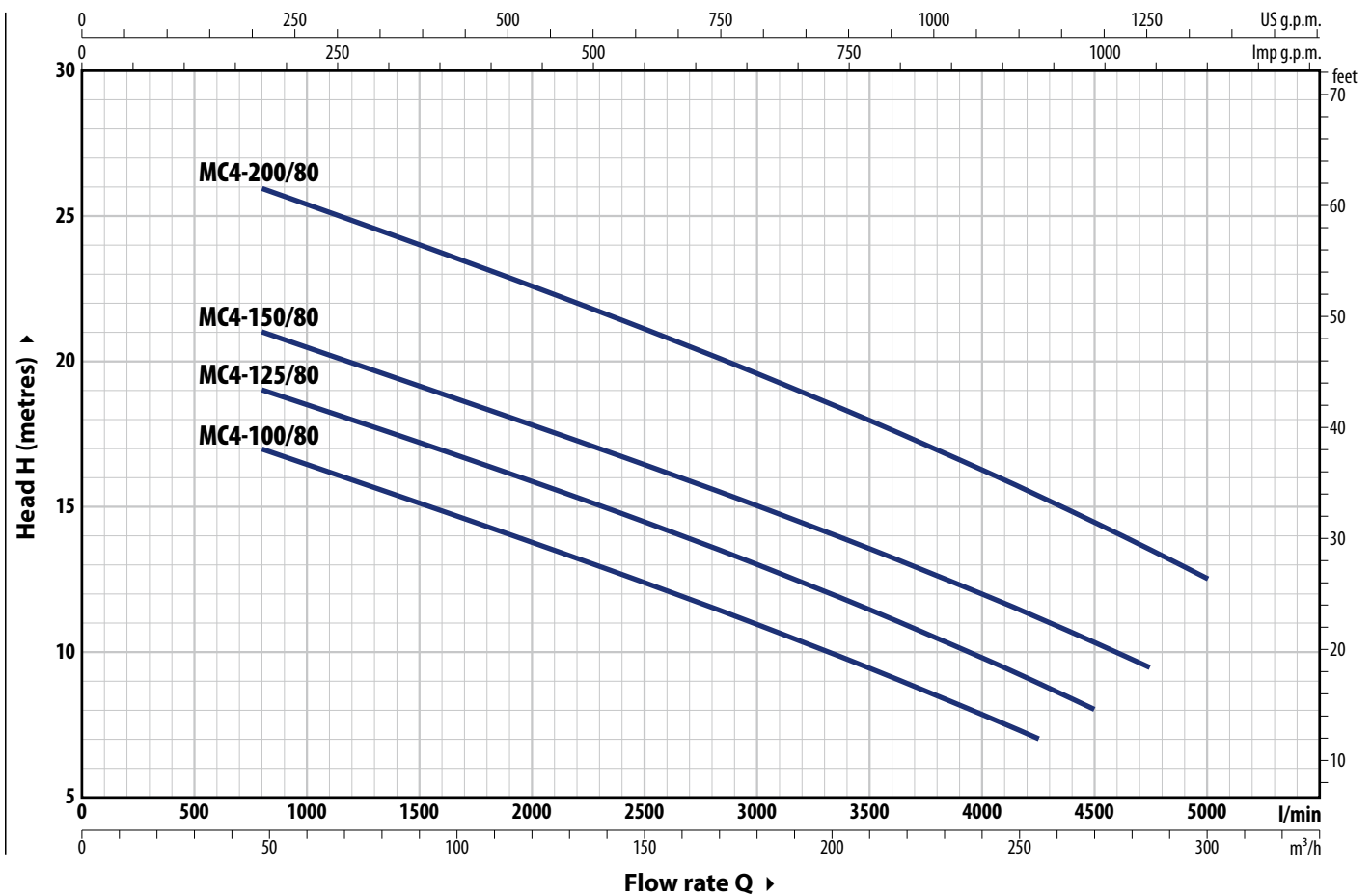

TYPE	POWER (P ₂)		Q	Flow rate											
	kW	HP		m ³ /h	0	48	60	120	180	240	255	270	285	300	
Three-phase			l/min	0	800	1000	2000	3000	4000	4250	4500	4750	5000		
MC4-100/80	7.5	10	H metres	19	17	16.4	13.7	11	7.8	7					
MC4-125/80	9.2	12.5		21	19	18.5	15.8	13	9.8	9	8				
MC4-150/80	11	15		23.5	21	20.7	18	15.2	12.1	11.3	10.4	9.5			
MC4-200/80	15	20		28	26	25.3	22.5	19.5	16.2	15.3	14.4	13.5	12.5		

Q = Flow rate H = Total manometric head

Performance curves comply with EN ISO 9906 Grade 3B tolerance limits.

ABSORPTION

TYPE	VOLTAGE			
	230 V - Δ	400 V - 人	400 V - Δ	690 V - 人
MC4-100/80	29.4 A	17.0 A	17.0 A	9.8 A
MC4-125/80	34.6 A	20.0 A	20.0 A	11.6 A
MC4-150/80	38.1 A	22.0 A	22.0 A	12.7 A
MC4-200/80	49.3 A	28.5 A	28.5 A	16.5 A

DIMENSIONS AND WEIGHT

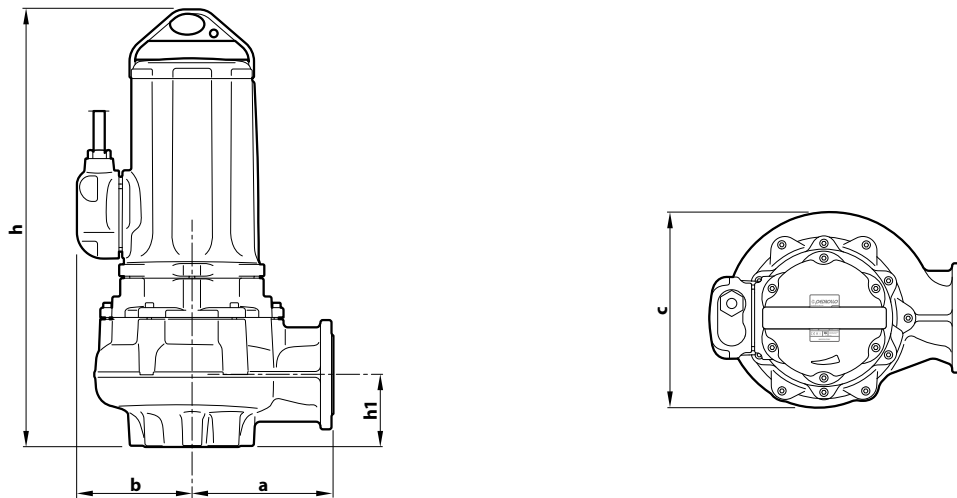

TYPE	Passage of solid bodies	DIMENSIONS mm					kg
		a	b	c	h	h1	
Three-phase	Ø 80 mm	285	228	395	858	130	3~
MC4-100/80							224
MC4-125/80							226
MC4-150/80							236
MC4-200/80							246

PORT FLANGE

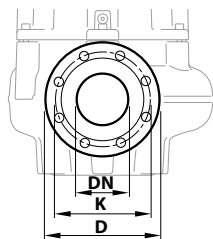

TYPE	FLANGE DN	K mm	D mm	HOLES	
				N°	Ø (mm)
Three-phase	100 (PN10)	180	220	8	18
MC4-100/80					
MC4-125/80					
MC4-150/80					
MC4-200/80					

COUNTERFLANGE

(CAN BE ORDERED SEPARATELY)

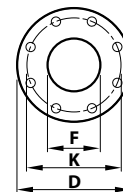

TYPE	FLANGE DN	F mm	K mm	D mm	HOLES	
					N°	Ø (mm)
Three-phase	100	4"	180	220	8	18
MC4-100/80						
MC4-125/80						
MC4-150/80						
MC4-200/80						

BASE

(CAN BE ORDERED SEPARATELY)

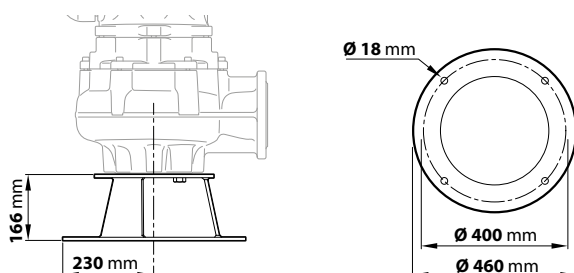

MATERIALS AND COMPONENTS

1 Pump body	Cast iron with cataphoresis treatment
2 Impeller	TWO-CHANNEL cast iron type with cataphoresis treatment
3 Motor holder	Cast iron
4 Motor cover	Cast iron
5 Motor shaft	Stainless steel AISI 431

6 Double mechanical seal with interposed oil chamber

Seal	Shaft	Location	Materials
MG1-43	Ø 43 mm	Motor side	Ceramic / Graphite / NBR
ARP-40	Ø 40 mm	Pump side	Silicon carbide/Silicon carbide/NBR

7 Electric Motor

Three-phase 230/400 V - 50 Hz or 400/690 V - 50 Hz
with winding integrated thermal three-phase motor protection to be connected to the switchboard

- Insulation: class F
- Protection rating: IP X8

8 ✖ Probe for detecting water in the oil chamber

9 Power cord

✖ 10 metres 'EM2 quality' type

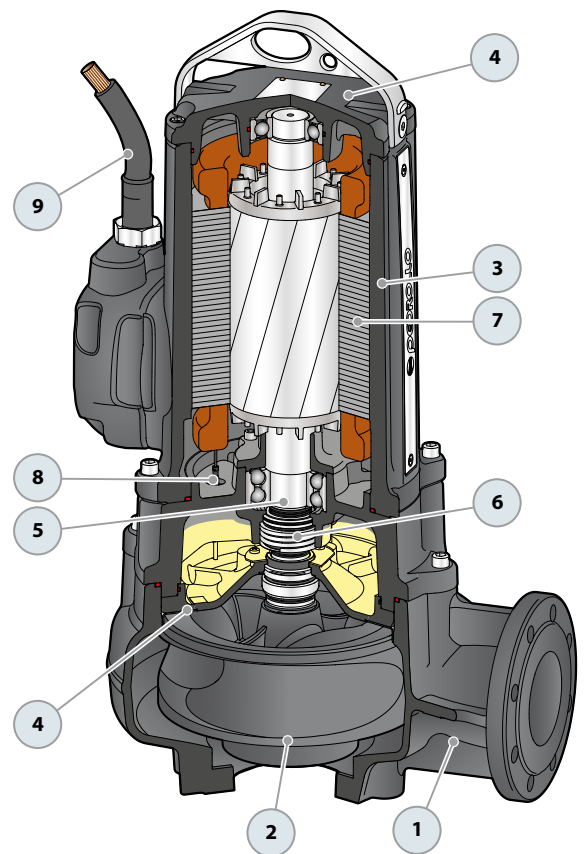

SEWAGE LIFTING SYSTEM VXC4 - MC4

VERSION WITH VERTICAL DELIVERY AND 2" GUIDE TUBES

For VXC4, MC4	Code ASSPVXC4V	DN 4"
----------------------	----------------	--------------

※ **Kit consisting of:**



Coupling foot complete with counterflange



Slide rail with screws and gasket



Support for guide tubes



ACCESSORIES AVAILABLE FOR ORDER

RUNNING GUIDE

※ For VXC4, MC4	Code ASSFL100
-----------------	---------------

Complete with screws and seals



INTERMEDIATE GUIDE TUBE SUPPORT

※ For guide tubes Ø 2"	Code 859SV349INTFA
------------------------	--------------------

For reasons of stability interpose a support every 3 metres



GUIDE TUBE (AISI 304 stainless steel)

※ 3 metres Ø 2" guide tube	Code 54SARTG0063F
※ 6 metres guide tube Ø 2"	Code 54SARTG0066F



Typical installation

1. Water pump
2. Pump Base
3. Guide Rails
4. Upper Guide Rail Support
5. Intermediate Guide Rail Support
6. Lifting chain
7. Control Panel
8. Stop Float Switch
9. Start Float Switch
10. Supplementary pump start float switch
11. Alarm float
12. Check valve
13. Pump Pedestal

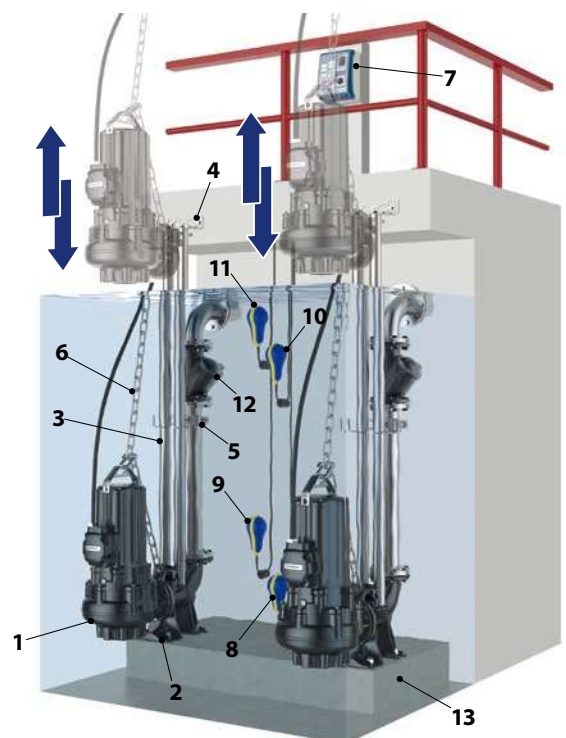

DIMENSIONS

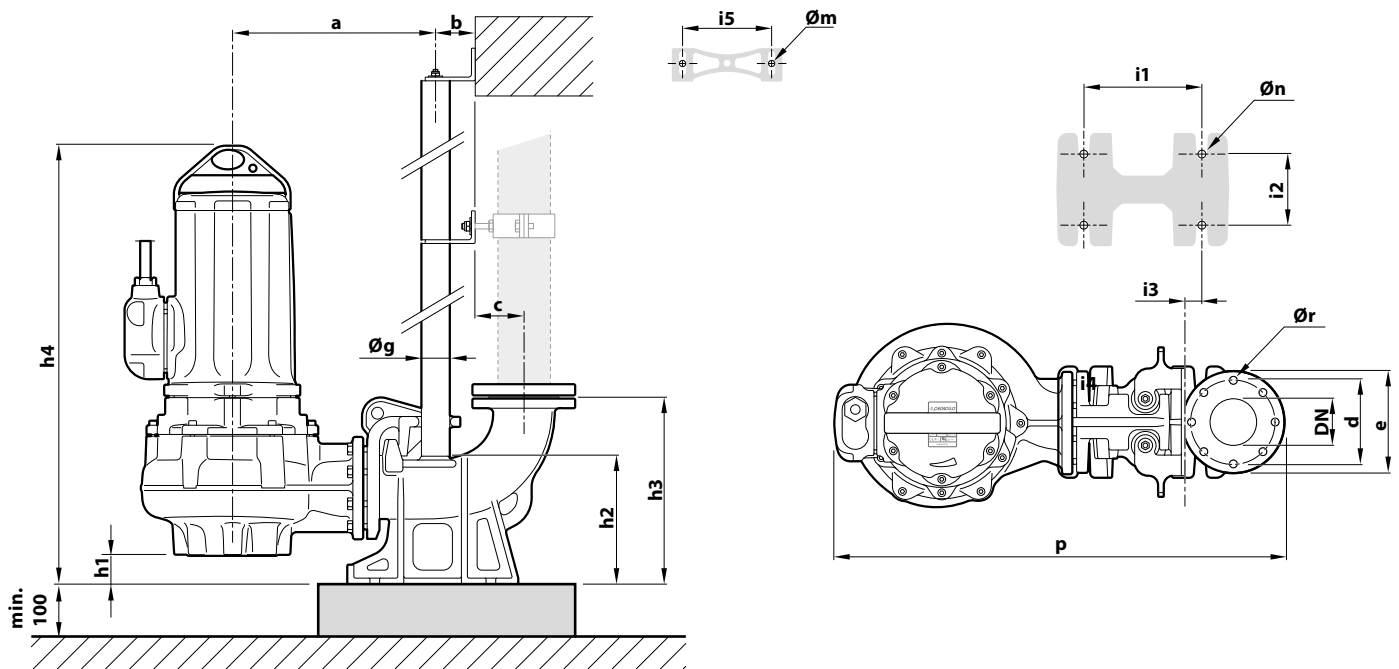

TYPE	Passage of solid bodies mm	PORT DN	DIMENSIONS mm																		
			a	b	c	d	e	p	h1	h2	h3	h4	i1	i2	i3	i5	Øg	Øm	Øn	Ør	
Three-phase																					
VXC4 /80	Ø 80 mm	100	435	85.5	104.5	180	220	965	77	275	400	935	250	150	34	187	2"	13.5	22	18	
MC4 /80																					



INSTALLATION AND USE

The **SAR 40** lift and collection stations are designed to handle clear water, rainwater, and wastewater from household drains like washing machines, dishwashers, and sinks, especially in situations where connection to the main sewer system is impractical or impossible due to distance or gravity constraints.

The **SAR 40** stations are compact and easy to install in basements, single-residence garages, or even underground.

COMPONENTS INCLUDED

- ✘ **40 litres** polyethylene tank with a non-walkable and non-driveable cover.
- ✘ Single-phase submersible pump.
- ✘ Standard **5-metres** power cable .
- ✘ Swing check valve for models with drainage pumps only (for clear wastewater).

AVAILABLE UPON REQUEST

- ✘ **SAR 40 lift station, equipped with a single-phase submersible pump with a float switch, based on your specific requirements.**
- ✘ **10-metres** power cable.
- ✘ Full-flow check valve (for external installation) designed for vortex and grinder pumps.



✘ SAR 40 with grinder pump

TYPE	POWER (P ₂)		MAXIMUM FLOW RATE litres/min	PREVALENCE MAX metres	
	kW	HP			
TRITUS-TX	0.55	0.75	90	11.5	

✘ Suitable for sewage



✘ Start of production 06.2024

✘ SAR 40 with drainage pumps

TYPE	POWER (P ₂)		MAXIMUM FLOW RATE litres/min	PREVALENCE MAX metres	
	kW	HP			
TOP 1 -GM	0.25	0.33	160	6.0	
RXm 1 -GM	0.25	0.33	160	7.0	

✘ Suitable for clear wastewater

✘ SAR 40 with vortex pumps

TYPE	POWER (P ₂)		MAXIMUM FLOW RATE litres/min	PREVALENCE MAX metres	
	kW	HP			
TOP 2 VORTEX-GM	0.37	0.50	155	7.0	
TEX 2	0.37	0.50	220	8.3	

✘ Suitable for dirty waste water

DIMENSIONS AND WEIGHT

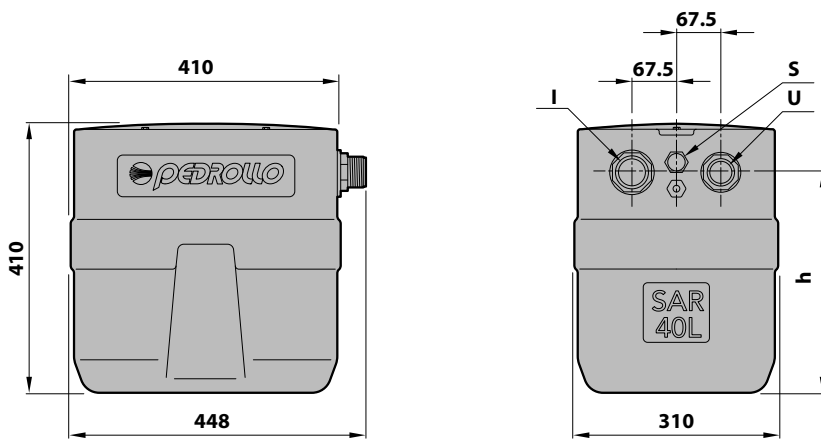

KEY:

- I** collection pipe connection
- U** discharge pipe connection
- S** ventilation pipe connection

TYPE	PORTS			h	kg
	I ⁽¹⁾	U ⁽¹⁾	S ⁽¹⁾		
SAR 40 - TRITUS-TX	1½"	1¼"	½"	335	15.9
SAR 40 - TOP 1-GM				305	14.3
SAR 40 - RXm 1-GM				305	15.2
SAR 40 - TOP 2 VORTEX-GM				335	14.4
SAR 40 - TEX 2				335	15.0

⁽¹⁾ Male threaded connection

EXAMPLES OF INSTALLATION

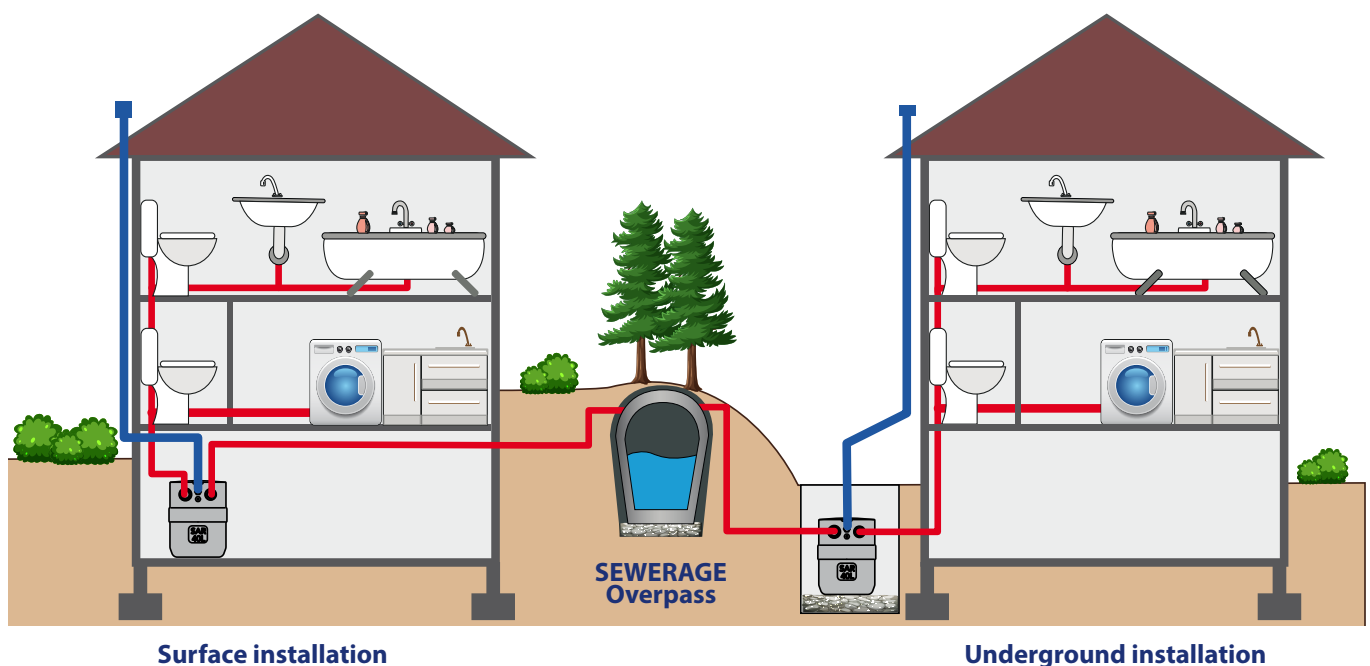

Surface installation

Underground installation



INSTALLATION AND USE

SAR 100 lift and collection stations are designed to handle clear water, rainwater, and wastewater from household drains like washing machines, dishwashers, sinks, and toilets, especially in situations where connection to the main sewer system is impractical or impossible due to distance or gravity constraints.

The **SAR 100** stations are compact and easy to install either on the floor or underground, both inside and outside of single or two-family homes.



COMPONENTS INCLUDED

- ※ **100 litres** polyethylene tank with a non-walkable and non-driveable cover.
- ※ Single-phase submersible pump.
- ※ Standard **10-metres** power cable.
- ※ Electrical panel (only for **SAR 100-TIGm 1.1** and **1.3**)

AVAILABLE UPON REQUEST

- ※ **SAR 100 lift station, equipped with a single-phase submersible pump with a float switch, based on your specific requirements**

※ SAR 100 with drainage pumps

TYPE	POWER (P ₂)		MAXIMUM FLOW RATE litres/min	PREVALENCE MAX metres	
	kW	HP			
TOP 3	0.55	0.75	260	10.0	
RXm 3	0.55	0.75	220	11.5	
Dm 10	0.75	1.0	300	15.5	
Dm 20	0.75	1.0	250	19.0	

※ suitable for clear wastewater

※ SAR 100 with vortex pumps

TYPE	POWER (P ₂)		MAXIMUM FLOW RATE litres/min	PREVALENCE MAX metres	
	kW	HP			
TOP 3-VORTEX	0.55	0.75	170	8.2	
RXm 3/20	0.55	0.75	240	9.5	
ZXm 2/30	0.55	0.75	320	12.5	
VXm 10/35	0.75	1.0	400	10.0	

※ suitable for dirty waste water

※ SAR 100 with grinder pumps (TRITUS)

TYPE	POWER (P ₂)		MAXIMUM FLOW RATE litres/min	PREVALENCE MAX metres	
	kW	HP			
TIGm 0.55	0.55	0.75	130	14.5	
TIGm 0.75	0.75	1.0	140	17.5	
TIGm 1.1	1.1	1.5	150	22.5	
TIGm 1.3	1.3	1.75	250	20.5	

※ suitable for sewage water

DIMENSIONS AND WEIGHT

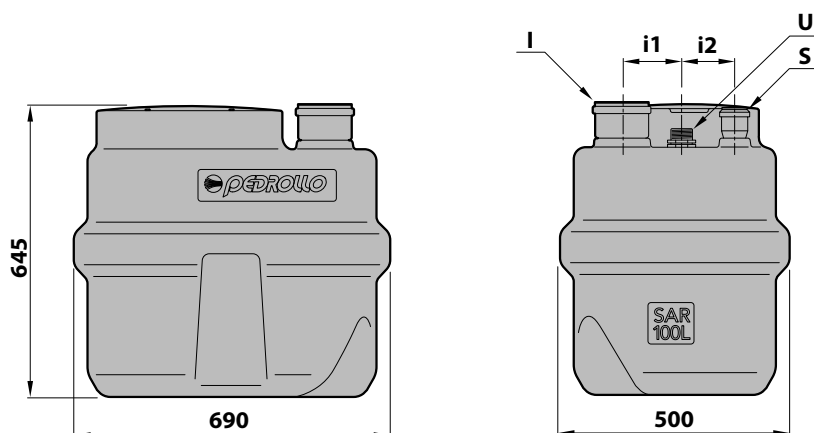

KEY:

- I collection pipe port
- U discharge pipe connection
- S ventilation pipe port

TYPE	PORTS			i1	i2	kg
	I	U ⁽¹⁾	S			
SAR 100 - TOP 3	DN 110	1¼"	DN 50	145	100	29.0
SAR 100 - RXm 3		1¼"				29.9
SAR 100 - Dm 10		1½"				36.3
SAR 100 - Dm 20		1½"				36.3
SAR 100 - TOP 3-VORTEX		1¼"				29.1
SAR 100 - RXm 3/20		1¼"				30.0
SAR 100 - ZXm 2/30		1½"				33.1
SAR 100 - VXm 10/35		1½"				37.5
SAR 100 - TIGm 0.55		1½"				38.2
SAR 100 - TIGm 0.75		1½"				38.3
SAR 100 - TIGm 1.1		1½"				40.6
SAR 100 - TIGm 1.3		1½"				40.6

⁽¹⁾ Male threaded connection

SAR 250

Lift and collection stations



INSTALLATION AND USE

SAR 250 lift and collection stations are designed to handle clear water, rainwater, and wastewater from household and civil drains like washing machines, dishwashers, sinks, and toilets, especially in situations where connection to the main sewer system is impractical or impossible due to distance or gravity constraints.

SAR 250 stations are compact and easy to install, suitable for floor or underground placement, both indoors and outdoors of multi-unit buildings.

COMPONENTS INCLUDED

- ✳ **SAR 250** polyethylene tank with a non-driveable cover that can support pedestrian traffic up to a maximum of 100 kg.
- ✳ Single-phase submersible pump.
- ✳ Electrical panel (only for **SAR 250-TIGm 1.1** and **1.3**).
- ✳ Standard **10-metres** power cable.

AVAILABLE UPON REQUEST

- ✳ **SAR 250 lift station, equipped with a single-phase submersible pump with a float switch, based on your specific requirements.**
- ✳ Three-phase submersible pump
- ✳ **Alarm kit** (Code: KSKIT-ALLARME) equipped with electrical panel, self-powered siren, and float
- ✳ **300 mm extension kit** (Code No. KSKIT-308MA) for installing the "SAR" tank at greater depths
- ✳ "SAR" Stations with check valve and ball valve in the discharge pipe.

✳ SAR 250 with drainage pumps

TYPE	POWER (P ₂)		MAXIMUM FLOW RATE litres/min	PREVALENCE MAX metres	
	kW	HP			
TOP 3	0.55	0.75	260	10.0	
TOP 4	0.75	1.0	320	12.5	
TOP 5	0.92	1.25	360	15.0	
RXm 3	0.55	0.75	220	11.5	
Dm 10	0.75	1.0	300	15.5	
Dm 20	0.75	1.0	250	19.0	
Dm 30	1.1	1.5	275	26.0	

✳ suitable for clear wastewater

✳ SAR 250 with VORTEX pumps

TYPE	POWER (P ₂)		MAXIMUM FLOW RATE litres/min	PREVALENCE MAX metres	
	kW	HP			
RXm 3/20	0.55	0.75	240	9.5	
ZXm 2/40	0.55	0.75	400	11	
VXm 10/35	0.75	1	400	10	
VXm 15/35	1.1	1.5	500	13.5	
VXm 15/50	1.1	1.5	650	11	

✳ suitable for dirty waste water

※ SAR 250 with grinder pumps (TRITUS)

TYPE	POWER (P ₂)		MAXIMUM FLOW RATE litres/min	PREVALENCE MAX metres	
	kW	HP			
TIGm 0.75	0.75	1.0	140	17.5	
TIGm 1.1	1.1	1.5	150	22.5	
TIGm 1.3	1.3	1.75	250	20.5	

※ suitable for sewage water

DIMENSIONS AND WEIGHT

TYPE	PORTS			kg
	I	U ⁽¹⁾	S	
SAR 250 - TOP 3	DN 110	1¼"	DN 50	49.7
SAR 250 - TOP 4		1½"		53.3
SAR 250 - TOP 5		1½"		54.3
SAR 250 - RXm 3		1¼"		50.6
SAR 250 - Dm 10		1½"		57.0
SAR 250 - Dm 20		1½"		57.0
SAR 250 - Dm 30		1½"		60.4
SAR 250 - RXm 3/20		1¼"		50.7
SAR 250 - ZXm 2/40		1½"		53.8
SAR 250 - VXm 10/35		1½"		58.2
SAR 250 - VXm 15/35		1½"		61.0
SAR 250 - VXm 15/50		2"		61.5
SAR 250 - TIGm 0.75		1½"		59.0
SAR 250 - TIGm 1.1		1½"		61.3
SAR 250 - TIGm 1.3		1½"		61.3

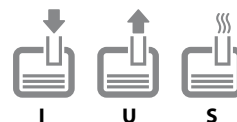
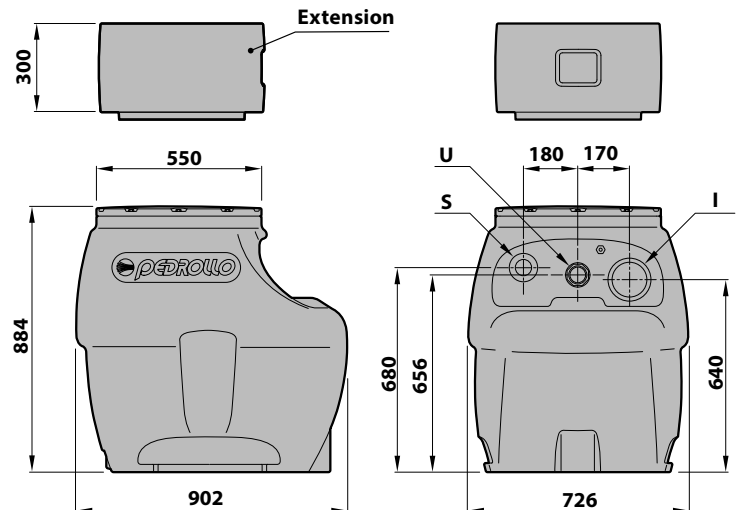

KEY:

- I** collection pipe port
- U** discharge pipe connection
- S** ventilation pipe port

⁽¹⁾ Male threaded connection



INSTALLATION AND USE

The **SAR 550** lift and collection stations are designed to handle clear water, rainwater, or dirty water from civil and industrial drains, where the sewer network is too far away or not accessible by gravity.

The **SAR 550** stations are compact and easy to install on the floor or underground, both indoors and outdoors of residential buildings, offices, public establishments, courtyards, and parking facilities, for sewage or rainwater disposal.

COMPONENTS INCLUDED

- ✳ **550 litres** polyethylene tank with a non-driveable cover that can support pedestrian traffic up to a maximum of 100 kg.
- ✳ **Two single-phase pumps (without float switches) pre-installed and already connected to a control panel.**
- ✳ Standard **10-metres** power cable .
- ✳ Electrical panel (**E2** model).
- ✳ Three float switches with the following functions:
 - 1) Alternating activation of one of the two pumps
 - 2) Activation of the second pump at maximum level
 - 3) Shutdown of the pump at minimum level



AVAILABLE UPON REQUEST

- ✳ **SAR 550 lift station, equipped with two single-phase pumps, based on your specific requirements.**
- ✳ **Three-phase submersible pump.**

OPTIONAL



- ✳ **Alarm kit** (Code: KSKIT-ALLARME) equipped with electrical panel, self-powered siren, and float
- ✳ **300 mm extension kit** (Code No. KSKIT-308MA) for installing the "SAR" tank at greater depths
- ✳ "SAR" Stations with check valve and ball valve in the discharge pipe

✳ SAR 550 with drainage pumps

TYPE	POWER (P ₂)		MAXIMUM FLOW RATE [1] pump litres/min	PREVALENCE MAX metres	
	kW	HP			
TOP 4	0.75	1	320	12.5	
TOP 5	0.92	1.25	360	15	
Dm 10	0.75	1	300	15.5	
Dm 20	0.75	1	250	19	
Dm 30	1.1	1.5	275	26	

✳ **suitable for clear wastewater**

✳ SAR 550 with VORTEX pumps

TYPE	POWER (P ₂)		MAXIMUM FLOW RATE [1] pump litres/min	PREVALENCE MAX metres	
	kW	HP			
VXm 10/35	0.75	1	400	10	
VXm 15/35	1.1	1.5	500	13.5	
VXm 10/50	0.75	1	550	8.5	
VXm 15/50	1.1	1.5	650	11	
BCm 10/50	0.75	1	600	11	
BCm 15/50	1.1	1.5	750	14	

✳ **suitable for dirty waste water**

※ SAR 550 with grinder pumps (TRITUS)

TYPE	POWER (P ₂)		MAXIMUM FLOW RATE [1] pump litres/min	PREVALENCE MAX metres	
	kW	HP			
TIGm 0.75	0.75	1	140	17.5	
TRm 0.9	0.9	1.25	170	15	
TRm 1.1	1.1	1.5	140	21.5	
TRm 1.3	1.3	1.75	220	22.5	
TRm 1.5	1.5	2	270	25	
TRm 2.2 AP	2.2	3	275	35	

※ suitable for sewage water

(*) On request "SAR" stations with coupling feet and guide pipes for pump descent

DIMENSIONS AND WEIGHT

TYPE	I	PORTS		kg
		U ⁽¹⁾	S	
SAR 550 - TOP 4	DN 110	1½"	DN 50	109.0
SAR 550 - TOP 5		1½"		110.9
SAR 550 - Dm 10		1½"		116.4
SAR 550 - Dm 20		1½"		116.4
SAR 550 - Dm 30		1½"		123.2
SAR 550 - VXm 10/35		1½"		118.8
SAR 550 - VXm 15/35		1½"	124.4	
SAR 550 - VXm 10/50		2	DN 75	119.8
SAR 550 - VXm 15/50		2		125.4
SAR 550 - BCm 10/50		2		120.8
SAR 550 - BCm 15/50		2		126.0
SAR 550 - TIGm 0.75		1½"		120.4
SAR 550 - TRm 0.9		1¼"		136.4
SAR 550 - TRm 1.1		1¼"	DN 50	139.7
SAR 550 - TRm 1.3		1¼"		139.4
SAR 550 - TRm 1.5		1½"		178.4
SAR 550 - TRm 2.2 AP	1½"	195.4		

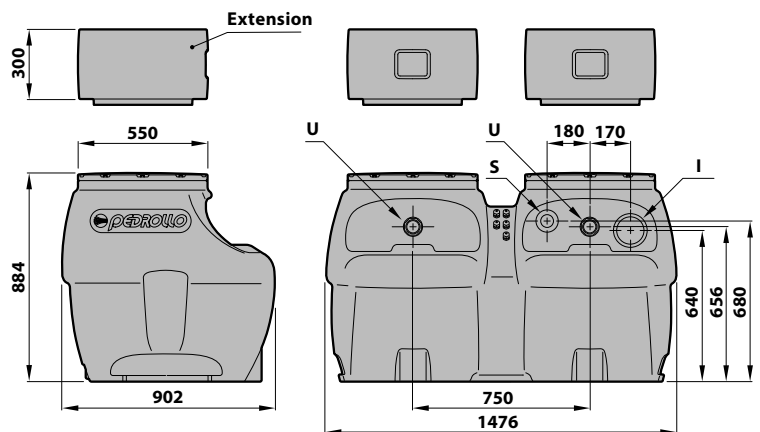

Only for TR versions with coupling feet

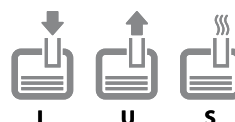
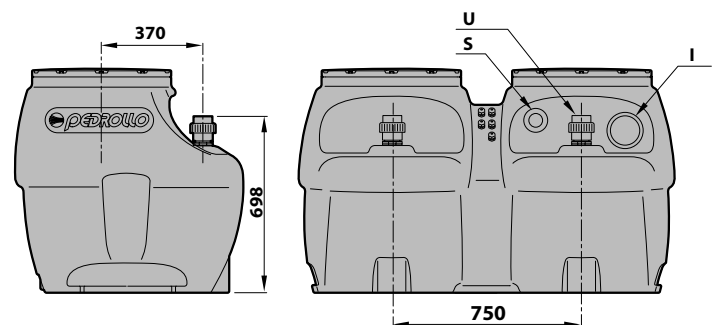

KEY:

- I collection pipe port
- U discharge pipe connection
- S ventilation pipe port

⁽¹⁾ Male threaded connection



COMPONENTS INCLUDED

- ※ Single-phase pump
- ※ EASYPRESS electronic control device with 1.5 bar restart pressure
- ※ GSR quick-connect coupling
- ※ 1.5 metres cable with Schuko plug

EXAMPLES OF INSTALLATION

- ※ To minimize frequent restarts resulting from brief usage or system leaks, it is advisable to install an expansion tank pre-filled to **1.2 bar** (e.g., tank 1SF).

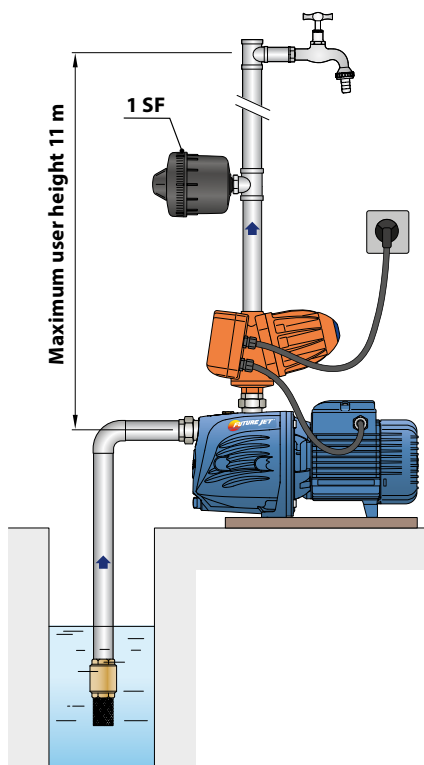

INSTALLATION AND USE

EASYPUMP is a ready-to-use and easy-to-install pressurization system, designed to increase water pressure for residential use or irrigation purposes.

EASYPUMP features a single-phase pump paired with an electronic control unit, known as EASYPRESS. EASYPRESS ensures automatic activation or deactivation of the pump based on water consumption, offering protection against dry running and system leaks. It also has an integrated non-return valve and a micro-accumulator that allows operation without the need for an expansion tank.

EASYPUMP activates automatically when the system's pressure drops below the preset threshold (**1.5 bar**) and continues to run as long as water is flowing.

TYPE	POWER (P ₂)		Q l/min	H metres
	kW	HP		
Single-phase				
3CPm 80-EP	0.45	0.60	5 – 80	38 – 5
4CPm 80-EP	0.55	0.75	5 – 80	50 – 10
4CPm 100-EP	0.75	1	5 – 130	50 – 5
3CRm 80-EP	0.45	0.60	5 – 80	38 – 5
4CRm 80-EP	0.55	0.75	5 – 80	50 – 10
4CRm 100-EP	0.75	1	5 – 130	50 – 5
CPm 158-EP	0.75	1	10 – 90	34 – 25
FUTURE JETm 2C - EP	0.75	1	5 – 120	52 – 10
FUTURE JETm 2A - EP	0.90	1.25	5 – 120	56 – 13.7
JCRm 2C - EP	0.75	1	5 – 70	51 – 24
JCRm 2A - EP	0.90	1.25	5 – 70	55 – 28
PLURIJETm 3/80-EP	0.48	0.65	5 – 80	38 – 5
PLURIJETm 4/80-EP	0.55	0.75	5 – 80	50 – 10
PLURIJETm 4/100-EP	0.75	1	5 – 130	50 – 5



HYDROFRESH 24 CL

COMPONENTS INCLUDED

- ※ Single-phase pump
- ※ Expansion tank
- ※ PSG-1 pressure switch
- ※ Pressure Gauge
- ※ Flexible hose
- ※ Brass fitting
- ※ 1.5 metres cable with Schuko plug

INSTALLATION AND USE

The **HYDROFRESH** group is designed for residential water supply or irrigation purposes and is available with a **24 litres** or a **60 litres** horizontal expansion tank. This cost-effective, ready-to-use system improves pressurization through two key features:

- an **expansion tank** designed to reduce the number of times the pump needs to turn on and counteract any loss of water pressure that occurs when you open a faucet
- a **pressure switch** that automatically controls the pump operation

TYPE	POWER (P ₂)		CAPACITY litres	FLOW RATE (1) litres/min	CALIBRATION (2) bar
	kW	HP			
HYDROFRESH 24 CL					
FUTURE JETm 1A - 24 CL	0.55	0.75	24	90	1.2 – 3.2
FUTURE JETm 2C - 24 CL	0.75	1	24	110	1.2 – 3.2
FUTURE JETm 1A-ST - 24 CL	0.55	0.75	24	90	1.2 – 3.2
FUTURE JETm 2C-ST - 24 CL	0.75	1	24	110	1.2 – 3.2

HYDROFRESH 60 CL

FUTURE JETm 1A - 60 CL	0.55	0.75	60	90	1.2 – 3.2
FUTURE JETm 2C - 60 CL	0.75	1	60	110	1.2 – 3.2
FUTURE JETm 1A-ST - 60 CL	0.55	0.75	60	90	1.2 – 3.2
FUTURE JETm 2C-ST - 60 CL	0.75	1	60	110	1.2 – 3.2

(1) Maximum flow rate corresponding to the minimum set pressure of the pressure switch

(2) Pressure switch calibration (recommended)

DIMENSIONS AND WEIGHT

HYDROFRESH 24 CL	DIMENSIONS mm			WEIGHT kg
	l	a	h	
FUTURE JETm 1A - 24 CL	535	255	520	18.7
FUTURE JETm 2C - 24 CL			530	22.0
FUTURE JETm 1A-ST - 24 CL			560	15.8
FUTURE JETm 2C-ST - 24 CL			570	19.2

HYDROFRESH 60 CL

FUTURE JETm 1A - 60 CL	730	340	657	23.7
FUTURE JETm 2C - 60 CL			675	27.0
FUTURE JETm 1A-ST - 60 CL	730	340	678	20.8
FUTURE JETm 2C-ST - 60 CL			703	24.2

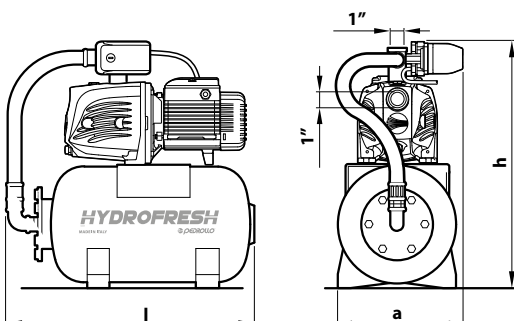

DG-BLU

Automatic pressurization system with inverter

-  Clean water
-  Domestic use
-  Civil use



PRODUCT DESCRIPTION

DG-BLU is a cutting-edge, automatic pressurization system featuring a high-efficiency, self-priming pump with multiple impellers. It comes complete with a storage tank, pressure and flow sensors, and a check valve, all designed to work quietly and efficiently.

This compact powerhouse stands out for its advanced electronic inverter control, which intelligently manages the system performance by:

- keeping the pressure constant according to water usage;
- monitoring hydraulic and electrical conditions to safeguard against malfunctions;
- allowing for integration with another DG-BLU unit through an optional expansion card;
- adapting seamlessly to any type of pressurization system, even existing ones;
- reducing electrical consumption with lower startup and running currents, achieving greater energy efficiency.

INSTALLATION AND USE

- ※ **DG-BLU** is designed to cater to the needs of single and two-family homes.
- ※ **DUAL-DG-BLU** units are pre-assembled pump systems, perfectly suited for multi-unit residences.

TECHNICAL DATA

- ※ Power supply: **1~ 230 V** ± 10%
- ※ Frequency: **50/60 Hz**
- ※ Insulation: **class F**
- ※ Maximum current absorbed:
 - **7.5 A** DG-BLU 3
 - **10 A** DG-BLU 5
- ※ Maximum power input P1:
 - **1.0 kW** DG-BLU 3
 - **1.5 kW** DG-BLU 5
- ※ Protection rating: **IP X4**
- ※ Set point from the factory: **3 bar**
- ※ 1.5 metres cable with Schuko plug

APPLICATION LIMITS

- Manometric suction head up to **8 m**
- Liquid temperature between **0 °C** and **+40 °C**
- Ambient temperature between **0 °C** and **+40 °C**
- Max. port pressure **4 bar**
- Max pressure **10 bar**
- Continuous running duty **S1**

PATENTS - TRADE MARKS - MODELS

- Registered community model No. 015048622-0001

CERTIFICATIONS IN PROGRESS



PERFORMANCE CURVES

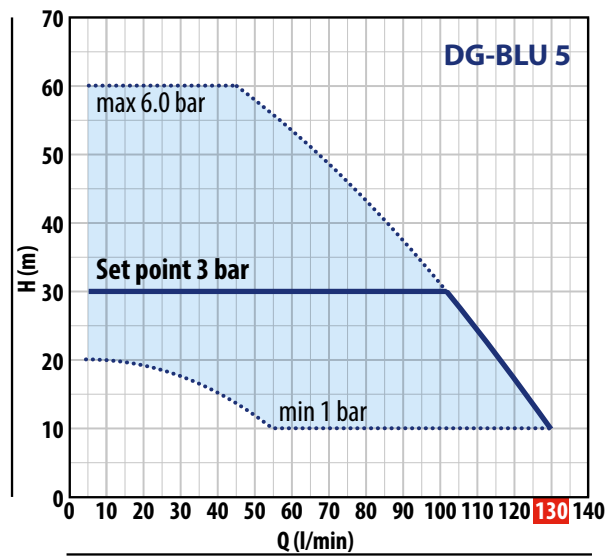
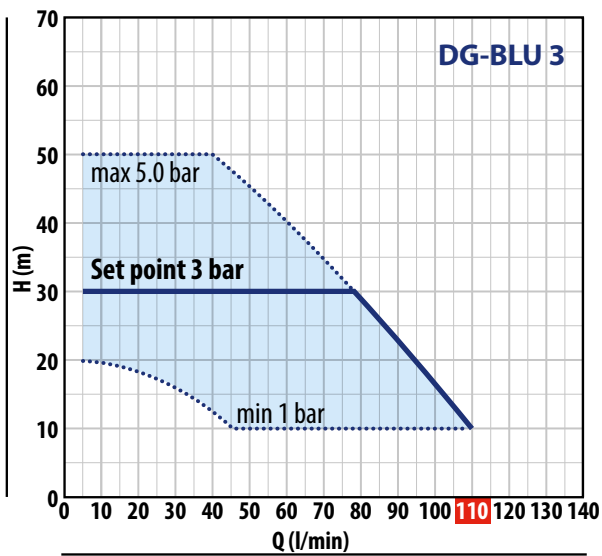

TYPE	POWER			PERFORMANCE		PERFORMANCE (ADJUSTABLE SET POINT)					
	P ₂		▲	Q	H	Set Point Min		Set Point Calibration Std		Set Point Max	
Single-phase	kW	HP		l/min	metres	bar	l/min	bar	l/min	bar	l/min
DG-BLU 3	0.75	1	IE3	5 – 110	50 – 10	1.0	45 – 110	3.0	5 – 79	5.0	5 – 40
DG-BLU 5	1.1	1.5		5 – 130	60 – 10	1.0	55 – 130	3.0	5 – 102	6.0	5 – 45

Q = Flow rate H = Total manometric head

▲ Efficiency three-phase motor (IEC 60034-30-1)

PERFORMANCE CURVES FOR A GROUP OF TWO DG-BLU UNITS

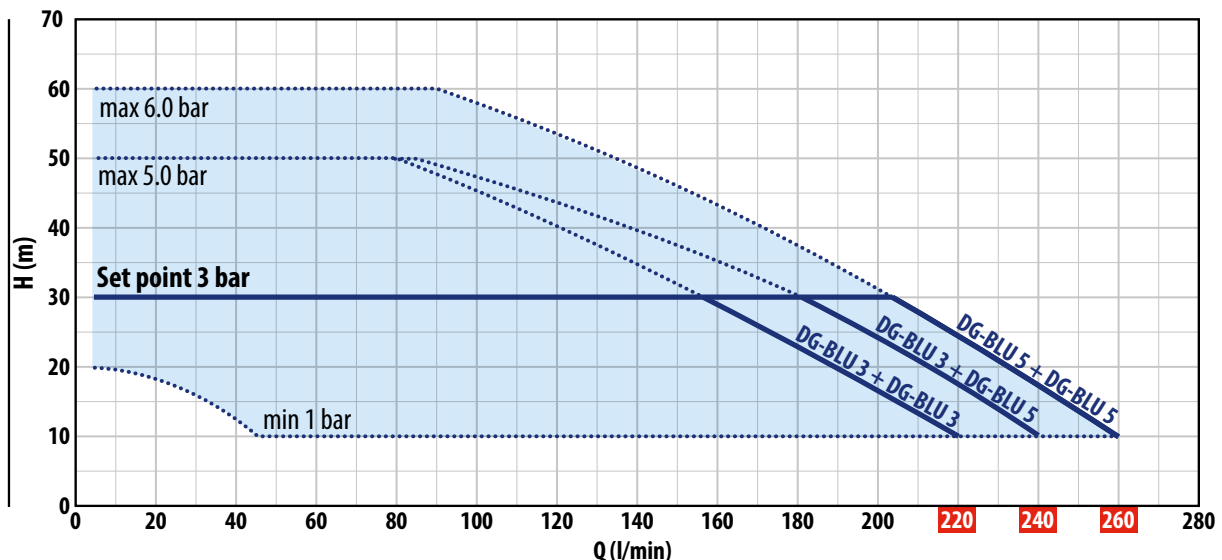

TYPE	POWER			PERFORMANCE		PERFORMANCE (ADJUSTABLE SET POINT)					
	P ₂		▲	Q	H	Set Point Min		Set Point Calibration Std		Set Point Max	
Single-phase	kW	HP		l/min	metres	bar	l/min	bar	l/min	bar	l/min
DUAL DG-BLU 3+3	0.75+0.75	1+1	IE3	5 – 220	50 – 10	1.0	45 – 220	3.0	5 – 158	5.0	5 – 80
DUAL DG-BLU 3+5	0.75+1.1	1+1.5		5 – 240	50 – 10	1.0	45 – 240	3.0	5 – 181	5.0	5 – 85
DUAL DG-BLU 5+5	1.1+1.1	1.5+1.5		5 – 260	60 – 10	1.0	55 – 260	3.0	5 – 204	6.0	5 – 90

Q = Flow rate H = Total manometric head

Performance curves comply with EN ISO 9906 Grade 3B tolerance limits.

▲ Three-phase motor efficiency (IEC 60034-30-1)

DG-BLU

KEY FEATURES



ALL IN ONE

- Self-priming multistage pump
- Frequency inverter
- Expansion tank
- Check valve
- Pressure and flow sensor



QUIET



COMPACT



CONSTANT PRESSURE



EASY TO USE



INSTALLABLE ANYWHERE

Thanks to its compactness, quiet operation, and 360° adjustable connections, DG-BLU can be installed anywhere

TYPICAL INSTALLATION

ABOVE GROUND

(drawing from a shallow tank or well)

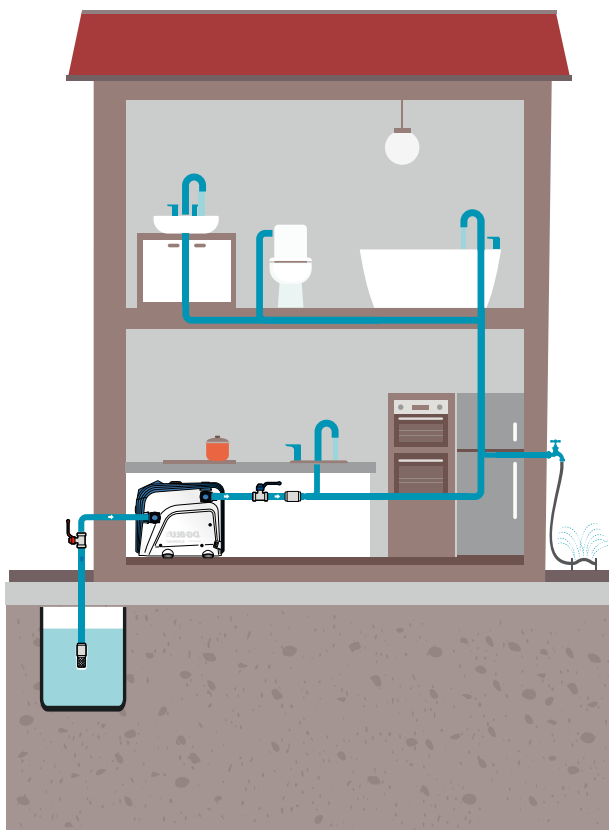

BELOW GROUND

(tank or aqueduct)

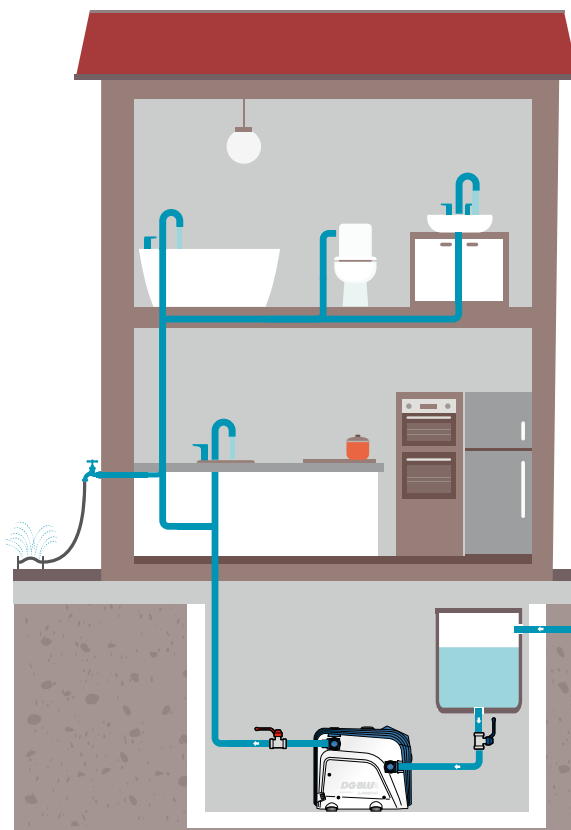

DIMENSIONS AND WEIGHTS (mm)

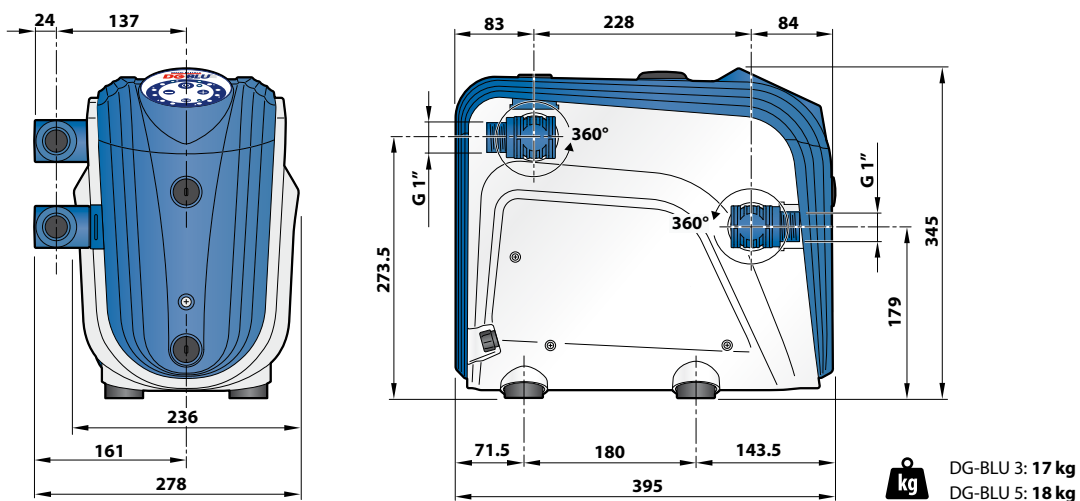

DUAL DG-BLU DIMENSIONS AND WEIGHTS (mm)

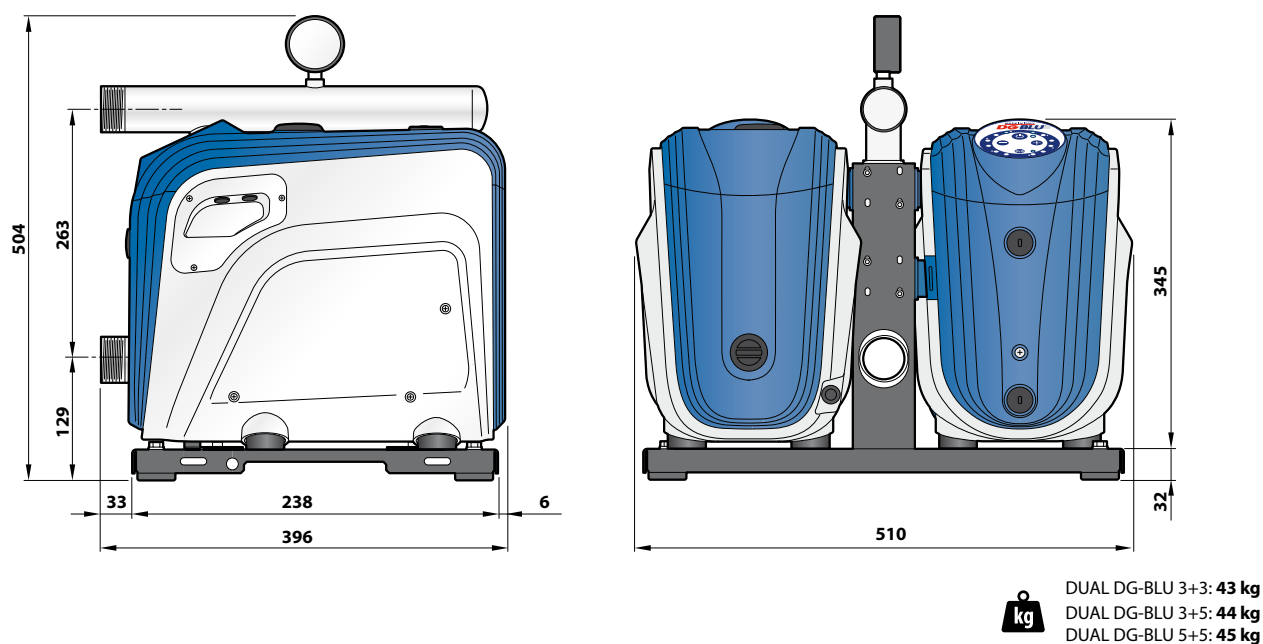

OPTIONAL ACCESSORIES



Connection kit for two DG-BLU units



Electronic expansion board



Kit for wall installation of a single DG-BLU



Wall installation kit of a two-unit group

EASYSMALL Automatic control device



TECHNICAL DATA

TYPE	P ₂		Power supply		Continuous duty current
	kW	HP	Volt	Hz	
Single-phase	1.1	1.5	230	50/60	10 A

PERFORMANCE RANGE

- ※ Restart pressure: **1.5 bar**
- ※ Max load capacity: **120 l/min** (7.2 m³/h)

APPLICATION LIMITS

- ※ Liquid temperature up to **+50 °C**
- ※ Ambient temperature up to **+40 °C**
- ※ Maximum operating pressure **10 bar**
- ※ Protection rating: **IP 65**

INSTALLATION AND USE

EASYSMALL is a compact and **cost-effective** electronic control and protection device for single-phase domestic pumps with power up to **1.5 HP**.

PRODUCT DESCRIPTION

- ※ **EASYSMALL** features a pressure sensor and a flow sensor linked to an electronic system that automatically activates the pump when a faucet's opening lowers the pressure below a specified level and deactivates it when the flow stops or dips under **2 l/min**.
- ※ **EASYSMALL** is also equipped with:
 - a pressure gauge for immediate pressure readings;
 - an integrated and inspectable check valve;
 - Two outlets to fit existing systems and to allow for the installation of a small expansion tank, ensuring better operation (**1SF**).

EASYSMALL's integrated electronics protect the pump from:

- ※ Dry running
- ※ frequent starts due to leaks in the system;
- ※ lockout due to system inactivity.

ACCESSORIES

- ※ **1SF 1 litre(1" M) technopolymer tank**



- ※ **GSR Special three-piece coupling with o-ring seal (1")**



PATENTS - TRADE MARKS - MODELS

- ※ Registered Community Model No. 001774928
- ※ **EASYSMALL**® registered trademark No. 0001511131

ADJUSTMENT

To avoid frequent restarts due to possible microleaks in the system and for greater energy savings, the **1SF** tank should be installed with a precharge of **1.2 bar**.

DIMENSIONS AND WEIGHT

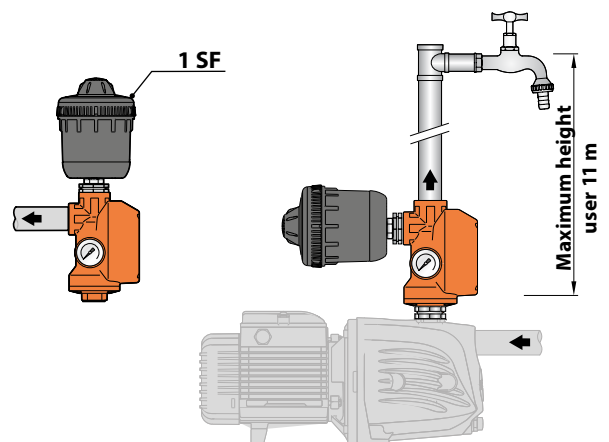
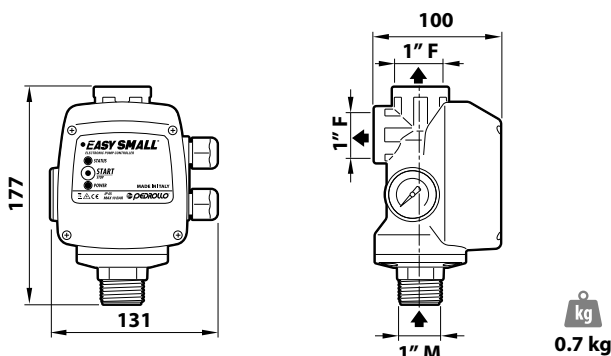



TECHNICAL DATA

TYPE	P ₂		Power supply		Continuous duty current
	kW	HP	Volt	Hz	
Single-phase					
EASYPRESS	1.5	2	230	50/60	13 A



OUT OF SERVICE



DRY RUNNING



FREQUENT START-UP

The **EASYPRESS** features 2 LED indicators to show the system's operating status and alerting to any issues through blinking patterns. A guide on the electrical panel helps to identify specific problems indicated by the LEDs..

PERFORMANCE RANGE

- ※ Restart pressure: **1.5 bar**
- ※ Maximum volume capacity: **170 l/min** (10 m³/h)

INSTALLATION AND USE

EASYPRESS is a durable and reliable electronic device designed to control and safeguard single-phase domestic pumps with a power capacity up to **2 HP**.

PRODUCT DESCRIPTION

※ **EASYPRESS** features a pressure sensor and a flow sensor linked to an electronic system that automatically activates the pump when a faucet's opening lowers the pressure below a specified level and deactivates it when the flow stops or dips under **2 l/min**.

- ※ **The EASYPRESS** is equipped with:
 - Circuit board
 - Pressure Gauge
 - Integrated micro-accumulation enables operation even without an expansion tank, though the use of a **1SF tank is recommended**.

The integrated electronics protect the pump from:

- ※ dry running
- ※ frequent start-ups due to leaks in the system;
- ※ lockout due to plant inactivity.

APPLICATION LIMITS

- ※ Liquid temperature up to **+55 °C**
- ※ Ambient temperature up to **+40 °C**
- ※ Maximum operating pressure **10 bar**
- ※ Protection rating: **IP 65**

PATENTS - TRADE MARKS - MODELS

- ※ Registered Community Model No. 868062
- ※ Patent No. IT 1388969, IT 1388970
- ※ **EASYPRESS®** registered trademark No. 0001334481

ACCESSORIES

- ※ **GSR** Special three-piece coupling with o-ring seal (1")



AVAILABLE UPON REQUEST

- ※ **EASYPRESS** version with **0.8 bar** restart pressure
- ※ **EASYPRESS** version with restart pressure **2.2 bar**
- ※ Version with power cable with Schuko plug and motor pump connection cable

Maximum user height



Typical installation

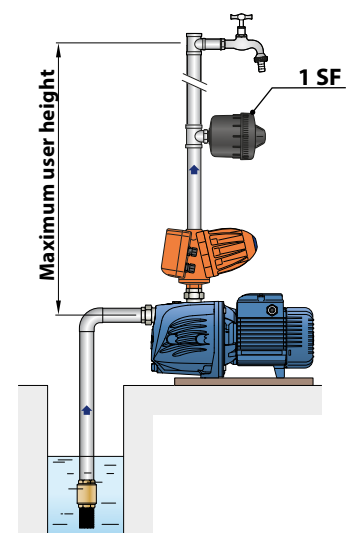

DIMENSIONS AND WEIGHT

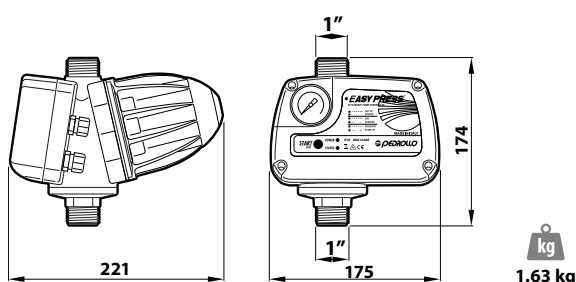

PRESFLO VARIO Automatic control device

 Clean water

 Domestic use



TECHNICAL DATA

TYPE	P ₂		Power supply		Continuous duty current
	kW	HP	Volt	Hz	
Single-phase	1.5	2	230	50/60	13 A

 **STANDBY**

 **DRY-RUN PROTECTION**

 **EXCESSIVE STARTS**

PRESFLO VARIO features 2 LED indicators to show the system's operating status and alerting to any issues through blinking patterns. A guide on the electrical panel helps to identify specific problems indicated by the LEDs.

INSTALLATION AND USE

PRESFLO VARIO is an electronic device designed to control and protect single-phase domestic pumps with a power capacity of up to 2 HP. It is ideal for water supply and pressure boosting in residential settings, as well as for small-scale irrigation applications.

PRODUCT DESCRIPTION

- ✳ **PRESFLO VARIO** features a pressure sensor and a flow sensor linked to an electronic system that automatically activates the pump when a faucet's opening lowers the pressure below a specified level and deactivates it when the flow stops or dips under **2 l/min**.
- ✳ **Adjustable restart pressure ranging from 0.8 bar to 2.4 bar.**
- ✳ **PRESFLO VARIO** is also equipped with:
 - Pressure Gauge
 - Integrated micro-accumulation enables operation even without an expansion tank, though the use of a **15F tank is recommended**;

The integrated electronics protect the pump from:

- ✳ dry running
- ✳ frequent start-ups due to leaks in the system.

DIMENSIONS AND WEIGHT

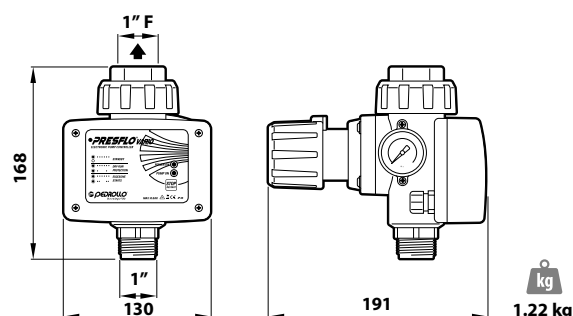

PERFORMANCE RANGE

- ✳ Maximum volume capacity: **170 l/min** (10 m³/h)
- ✳ Restart pressure: **adjustable** (factory setting **1.5 bar**)

APPLICATION LIMITS

- ✳ Liquid temperature up to **+40 °C**
- ✳ Ambient temperature up to **+40 °C**
- ✳ Maximum operating pressure **10 bar**
- ✳ Protection rating: **IP 65**

PERFORMANCE AND SAFETY STANDARDS

The electronic circuit board inside the **PRESFLO VARIO** has passed the most rigorous **EMC tests** for electromagnetic compatibility.

AVAILABLE UPON REQUEST

- ✳ Version with power cable with Schuko plug and pump connection cable

ADJUSTMENT

PRESFLO VARIO has a knob for quick and intuitive adjustment of the restart pressure from a minimum of **0.8 bar** to a maximum of **2.4 bar**

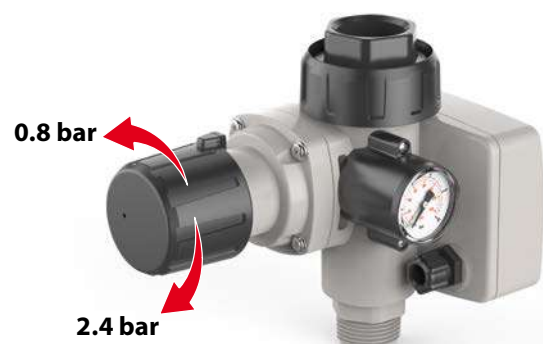



TECHNICAL DATA

TYPE	P ₂		Power supply		Continuous duty current
	kW	HP	Volt	Hz	
Single-phase	1.5	2	230	50/60	13 A

	STANDBY
	DRY-RUN PROTECTION
	EXCESSIVE STARTS
	OVERLOAD

PRESFLO MULTI features 2 LED indicators to show the system's operating status and alerting to any issues through blinking patterns. A guide on the electrical panel helps to identify specific problems indicated by the LEDs.

PERFORMANCE RANGE

- ✘ Maximum volume capacity: **170 l/min** (10 m³/h)
- ✘ Adjustable restart pressure (factory setting **2 bar**)
- ✘ maximum current: **adjustable** up to **16 A**.

APPLICATION LIMITS

- ✘ Liquid temperature up to **+40 °C**
- ✘ Ambient temperature up to **+40 °C**
- ✘ Maximum operating pressure **8 bar**
- ✘ Protection rating: **IP 65**

PERFORMANCE AND SAFETY STANDARDS

The electronic circuit board inside the **PRESFLO MULTI** has passed the most rigorous **EMC tests** for electromagnetic compatibility.

AVAILABLE UPON REQUEST

- ✘ Version with power cable with Schuko plug and pump connection cable

ADJUSTMENT

PRESFLO MULTI is equipped with two trimmers and a screwdriver for simple and intuitive adjustment of:

- restart pressure from **1 bar** to **5 bar**
- amperometric protection from **4** to **16 A**

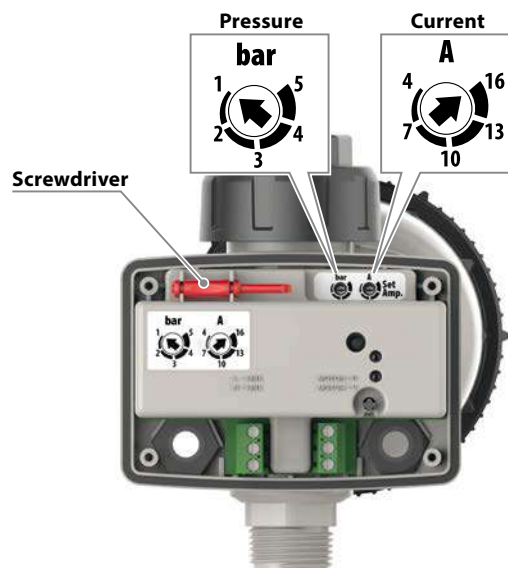

INSTALLATION AND USE

PRESFLO MULTI is an electronic device designed to control and protect single-phase domestic pumps with a power capacity of up to 2 HP. It is ideal for water supply and pressure boosting in residential settings, as well as for small-scale irrigation applications.

PRODUCT DESCRIPTION

- ✘ **PRESFLO MULTI** features a pressure sensor and a flow sensor linked to an electronic system that automatically activates the pump when a faucet's opening lowers the pressure below a specified level and deactivates it when the flow stops or dips under **2 l/min**.
- ✘ **PRESFLO MULTI** is also equipped with:
 - Pressure Gauge
 - integrated **1-litre** expansion tank useful in case of leaks and to protect against water hammer;
 - option to adjust the restart pressure from **1 bar** to **5 bar**;
 - capability to set the maximum current up to **16 A**

The integrated electronics protect the pump from:

- ✘ dry running
- ✘ frequent start-ups due to leaks in the system;
- ✘ Overcurrent

DIMENSIONS AND WEIGHT

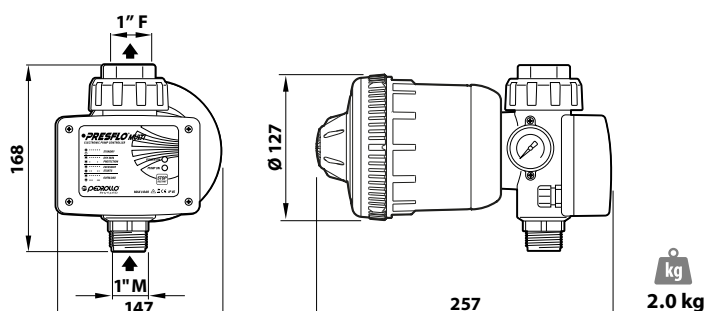

PRESET Electronic pressure switch:



Clean water



Domestic use



TECHNICAL DATA

TYPE	P ₂		Power supply		Continuous duty current
	kW	HP	Volt	Hz	
Single-phase					
PRESET	1.5	2	230	50/60	13 A

PERFORMANCE RANGE

- ※ Running pressure: adjustable from **0.8 to 9 bar** (factory setting at **2 bar**)
- ※ Cut-off pressure: adjustable from **1 to 9.2 bar** (factory setting **3 bar**)
- ※ Maximum current: adjustable (factory setting **16 A**)

APPLICATION LIMITS

- ※ Liquid temperature up to **+40 °C**
- ※ Ambient temperature up to **+40 °C**
- ※ Maximum working pressure: **10 bar**
- ※ Protection rating: **IP 65**

PERFORMANCE AND SAFETY STANDARDS

The circuit board inside the **PRESET** has passed the most stringent **EMC tests** for electromagnetic compatibility.

ADJUSTMENT

INSTALLATION AND USE

PRESET is an electronic device ideal for the control and protection of single-phase domestic pumps with power up to 2 HP, in connection with autoclaves for water supply and pressure boosting in domestic applications and for residential irrigation systems.

PRODUCT DESCRIPTION

- ※ **PRESET** activates the pump when opening a faucet reduces system pressure below the operational threshold and turns it off once pressure surpasses the shut-off limit, serving as a modern alternative to conventional mechanical pressure switches.
- ※ **PRESET** is equipped with:
 - **pressure sensor enabling accurate digital control of start and stop pressures from 0.8 to 9 bar;**
 - display for reading the operating parameters;
 - integrated and inspectable non-return valve.

The integrated electronics protect the pump from:

- ※ dry running
- ※ frequent start-ups due to leaks in the system;
- ※ Overcurrent

DIMENSIONS AND WEIGHT

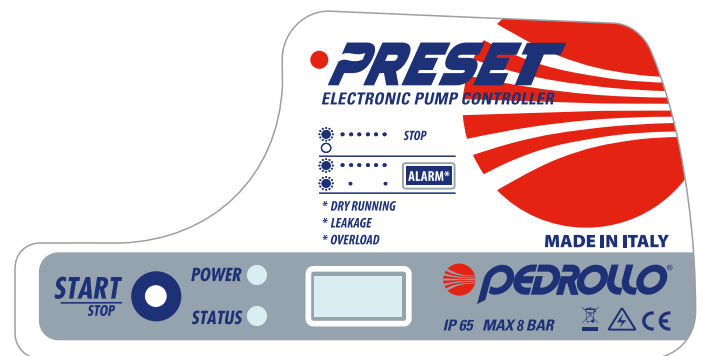
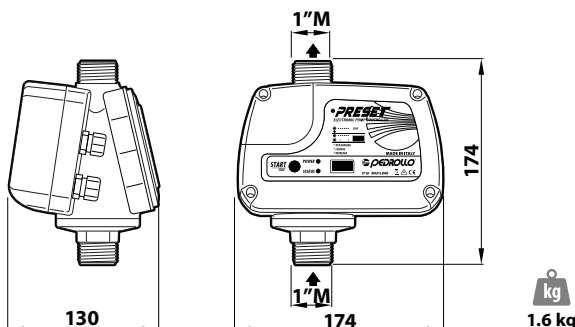

Pressing the **START** button begins a **step-by-step guide to configure PRESET**, which involves setting specific parameters:

- ※ operating pressure (M)
- ※ shut-off pressure (A)
- ※ maximum allowed current (C)
- ※ operating time at no flow (TD)
- ※ restart time after shutdown (TP)



ELECTRICAL PANEL

- Key with **START/STOP** function, self-learning and alarm reset.
- Multicoloured LED indicator. It flashes and changes colour depending on the status of the EP device.

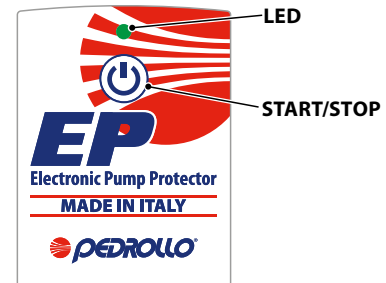

PRODUCT DESCRIPTION

EP is an electronic device designed to safeguard the pump by automatically shutting it off in case of:

- ✘ Dry running
- ✘ Overcurrent
- ✘ Overvoltage
- ✘ Undervoltage

TECHNICAL DATA

Single-phase supply voltage	110/230 V ±10
Frequency	50-60 Hz
Maximum pump current	16 A
Maximum pump power	2 HP
Operating temperature	From -5 to 45 °C
Maximum ambient temperature	55 °C
Protection rating	IP 55

INSTALLATION

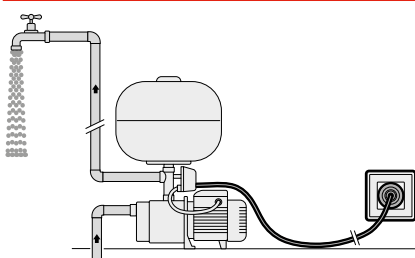

Fig. 1

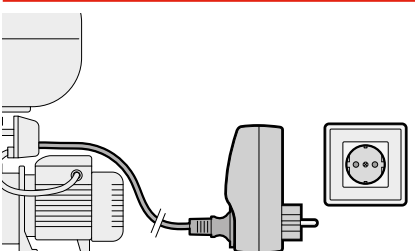

Fig. 2

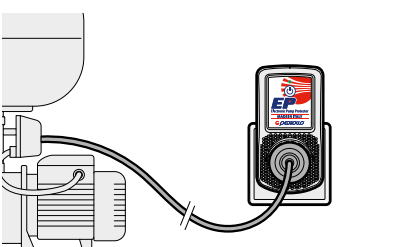

Fig. 3

LED light description	Meaning of the LED light
Indicator light OFF:	Device off
Steady GREEN light	Powered Device
Steady BLUE light	Device in regular operation
Flashing RED light	Dry running
Red light fixed	Overcurrent
Steady YELLOW light	Overvoltage/undervoltage
Continuously variable colour indicator	Self-learning phase (WIZARD)

INSTALLATION AND OPERATION

After verifying the water system is functioning correctly, proceed with the following steps:

- ✘ Operate the pump with the delivery point open (**Fig. 1**).
- ✘ Disconnect the plug of the pump's power cable from the power socket, leaving the supply point open, and drain the system completely (**Fig. 2**).
- ✘ Insert the pump's power cable plug into the EP device (**Fig. 2**).
- ✘ Plug the EP device into the outlet (**Fig. 3**) and start the self-learning procedure (see instruction manual).

After completing the self-learning procedure, the system is ready for use.



VIDEO TUTORIAL



INSTALLATION AND USE

STEADYPRES is an inverter-based electronic control device compatible with both surface and submersible pumps, SINGLE-PHASE or THREE-PHASE, up to **1.5 HP (1.1 kW)**. Designed for domestic water supply and irrigation, it seamlessly integrates with any pressurization system, including existing setups, to enhance comfort, extend system lifespan, and achieve significant energy savings.

PRODUCT DESCRIPTION

STEADYPRES is connected to the pump's delivery system and adjusts the motor's rotation speed by modulating the output voltage's value and frequency. This adaptation is based on the required water flow, ensuring constant pressure within the system.

STEADYPRES components:

- electronic frequency converter (inverter);
- integrated pressure and flow sensors;
- electrical panel with keypad and LED indicators for intuitive parameter reading;
- integrated and inspectable non-return valve;
- rear threaded connection to equip the system with a small expansion tank.

STEADYPRES protects the pump from:

- ✘ Dry running
- ✘ Overcurrent
- ✘ Undervoltage
- ✘ Overheating
- ✘ Short circuit or current leakage

VERSATILE PRODUCT

STEADYPRES can be paired with both single-phase and three-phase pumps, featuring internal switches for configuration settings of

- ✘ **the output frequency at 50 Hz or 60 Hz**
- ✘ **the output supply voltage**
(single-phase or three-phase 230V)



N	Position	Selector switch position	Value
1	Operating FREQUENCY	ON	60 Hz
		OFF	50 Hz
2	SINGLE-PHASE or THREE-PHASE output	ON	MT (three-phase)
		OFF	MM (single-phase)

KEY FEATURES

- ✘ Quick and intuitive pressure adjustment via +/- buttons (**1-9 bar**)
- ✘ Energy-saving with reduced pump absorption
- ✘ Reduced noise operation
- ✘ Minimal pressure drops
- ✘ Extended pump lifespan

OPTIONAL

- ✘ **Expansion board** enables parallel connection of up to two devices, forming pumping groups.

TECHNICAL DATA

	M/M USE (Single-phase / Single-phase)	M/T USE (Single-phase / Three-phase)
Power supply voltage	1 ~ 230 V	1 ~ 230 V
Pump motor voltage	1 ~ 230 V	3 ~ 230 V
Permissible voltage variation	± 10%	± 10%
Supply frequency	50/60 Hz	50/60 Hz
Maximum electric pump motor current	8.5 A	7.0 A
Maximum electric pump motor power	1.5 HP	1.5 HP
Setting pressure	1÷9 bar	1÷9 bar
Maximum liquid temperature	+40 °C	+40 °C
Room temperature	0 °C ÷ 40 °C	0 °C ÷ 40 °C
Maximum pressure	10 bar	10 bar
Protection rating	IP 65	IP 65

ELECTRICAL PANEL



KEY

- 1) ON/OFF button
- 2) Operation and alarm LED indicators
- 3) Increase pressure button
- 4) Decrease pressure button
- 5) Operating status LED

DIMENSIONS AND WEIGHT (mm)

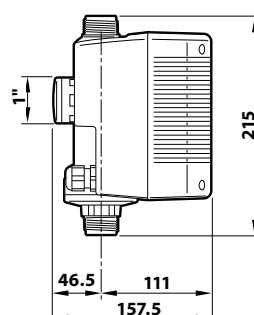
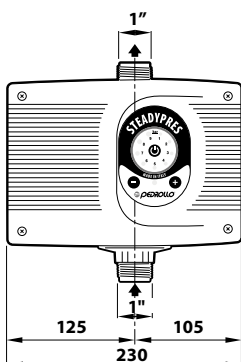

 2.4 kg

TYPICAL INSTALLATION

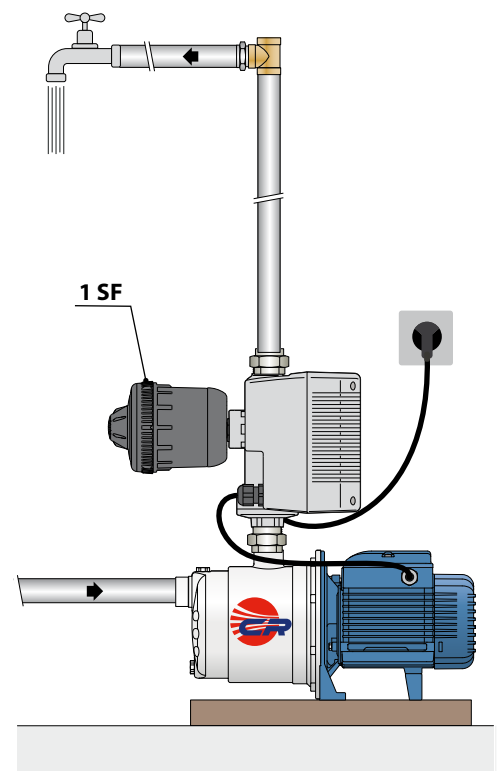

N.B.: It's advisable to install a membrane EXPANSION TANK (1SF) downstream of the inverter to:

- ※ decrease pump start frequency
- ※ absorb excess pressure from the system, like water hammer

-  Clean water
-  Domestic use
-  Civil use



INSTALLATION AND USE

STEADYPRES is an electronic device that manages and controls both surface and submersible pumps using inverter technology.

STEADYPRESit is designed for water supply in homes, businesses, and for irrigation purposes. Suitable for all kinds of pressurization systems, including existing ones, STEADYPRES enhances comfort, extends the system's lifespan, and significantly reduces energy consumption.

PRODUCT DESCRIPTION

STEADYPRES is connected to the pump's delivery system and regulates the motor's rotation speed by adjusting the voltage and frequency of the output, in response to water flow demand, ensuring constant pressure within the system.

STEADYPRES components:

- electronic frequency converter (inverter);
- pressure and flow sensor;
- electrical panel with keypad and display to facilitate setting and reading operations;
- integrated and inspectable non-return valve.

STEADYPRES features include:

- ※ A display and keypad for easy, step-by-step setup of operating parameters with two levels of adjustment:
 - BASIC, for setting pressure and current;
 - ADVANCED, for customizing the inverter for specific system needs.
- ※ Internal electronic components are cooled as water flows through the device, helping to dissipate heat.

STEADYPRES protects the pump from:

- ※ Dry running
- ※ Overcurrents
- ※ Overvoltage
- ※ Undervoltage
- ※ Overheating
- ※ Short circuit
- ※ Phase failure in connections (for TT version)

KEY FEATURES

- ※ Easy installation, adjustment and setting.
- ※ Energy saving due to lower absorption of the pump.
- ※ Control of hydraulic and electrical operating parameters and protection against faults.
- ※ Reduced noise operation.
- ※ Longer pump life.

OPTIONAL A RICHIESTA

- ※ **Expansion board**, which allows:
 - RS485 communication to link up to three STEADYPRES inverters and create pumping groups;
 - alternating pump operation;
 - configuration of a dry input contact (e.g. float, double set point);
 - configuration of a dry output contact (e.g. alarm)

TECHNICAL DATA	STEADYPRES MM 11	STEADYPRES MM 16	STEADYPRES MT 10	STEADYPRES TT 6	STEADYPRES TT 8
Power supply voltage	1 ~ 230 V	1 ~ 230 V	1 ~ 230 V	3 ~ 400 V	3 ~ 400 V
Pump motor voltage	1 ~ 230 V	1 ~ 230 V	3 ~ 230 V	3 ~ 400 V	3 ~ 400 V
Permissible voltage variation	± 10%	± 10%	± 10%	± 10%	± 10%
Supply frequency	50/60Hz	50/60Hz	50/60Hz	50/60Hz	50/60Hz
Maximum pump motor current	11 A	16 A	10 A	6 A	8 A
Maximum pump motor power	2 HP (1.5 kW)	3 HP (2.2 kW)	3 HP (2.2 kW)	3 HP (2.2 kW)	4 HP (3 kW)
Setting pressure	1÷10 bar	1÷10 bar	1÷10 bar	1÷10 bar	1÷10 bar
Maximum liquid temperature	+40 °C	+40 °C	+40 °C	+40 °C	+40 °C
Room temperature	0 °C ÷ 40 °C	0 °C ÷ 40 °C	0 °C ÷ 40 °C	0 °C ÷ 40 °C	0 °C ÷ 40 °C
Maximum pressure	10 bar	10 bar	10 bar	10 bar	10 bar
Protection rating	IP 65	IP 65	IP 65	IP 65	IP 65
Weight	3 kg	4 kg	3 kg	4 kg	4 kg

ELECTRICAL PANEL

- ※ The keypad makes it easy to access and navigate through configuration menus, allowing you to adjust and view various operating parameters such as system pressure, operating frequency, absorbed current, and alarm messages.
- ※ LED light signals indicate the pump's operating status for quick checking.

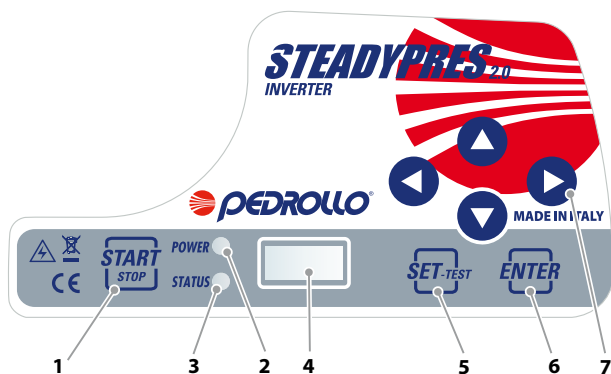

KEY

- | | |
|-----------------------|------------------------------|
| 1) ON/OFF button | 5) SET button |
| 2) Red networking LED | 6) ENTER confirmation button |
| 3) Green run LED | 7) Scroll Arrows |
| 4) Display | |

DIMENSIONS (mm)

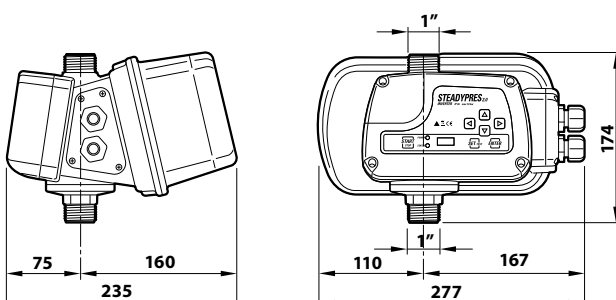

TYPICAL INSTALLATION

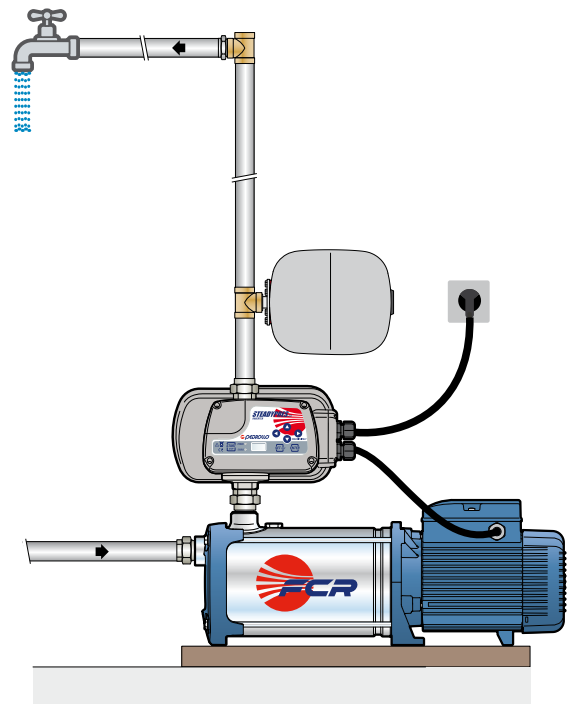

N.B.: it's advisable to install a membrane EXPANSION TANK downstream of the inverter to:

- ※ decrease pump start frequency
- ※ absorb excess pressure from the system, like water hammer

 Domestic use

 Civil use



INSTALLATION AND USE

DG FIT is an inverter-based electronic control device designed for single-phase surface or submersible pumps.

It is utilized for water supply in residential, commercial, and irrigation applications, and is compatible with all types of pressurization systems, including existing ones.

DG FIT ensures maximum comfort, extends the system's service life, and facilitates significant energy savings.

DG FIT protects the pump from:

- ✘ Dry running
- ✘ Overcurrent
- ✘ Overvoltage
- ✘ Undervoltage
- ✘ Overheating
- ✘ Short circuit

PRODUCT DESCRIPTION

DG FIT is a wall-mounted frequency converter which, equipped with a pressure sensor, allows the rotation speed of the motor to adjust dynamically according to the amount of water required, thus ensuring constant pressure in the system.

DG FIT is characterised by:

- ✘ A display and keypad for easy, step-by-step setup of operating parameters with two levels of adjustment:
 - **BASIC**, for setting pressure and current;
 - **ADVANCED**, for customizing the inverter for specific system needs.
- ✘ Electronic components are cooled by an integrated fan to ensure heat dissipation.
- ✘ Integrated expansion board, which allows:
 - RS 485 communication for up to three **DG FIT** to talk to each other
 - configuration of a dry input contact (e.g. float, double set point)
 - configuration of a dry output contact (e.g. alarm)
- ✘ Input signal: pressure sensor
- ✘ Arrangement for wall connection

ADVANTAGES IN USE

- ✘ Easy installation, adjustment and setting.
- ✘ Energy saving due to lower absorption of the pump.
- ✘ Control of hydraulic and electrical operating parameters and protection against faults.
- ✘ Reduced noise operation.
- ✘ Longer pump life.
- ✘ Possibility to connect up to three devices to create pressurization units

TECHNICAL DATA	DG FIT MM 8	DG FIT MM 11	DG FIT MM 16
Power supply voltage	1 ~ 230 V	1 ~ 230 V	1 ~ 230 V
Pump motor voltage	1 ~ 230 V	1 ~ 230 V	1 ~ 230 V
Permissible voltage variation	± 10%	± 10%	± 10%
Supply frequency	50/60Hz	50/60Hz	50/60Hz
Maximum pump motor current	8.5 A	11 A	16 A
Maximum pump motor power	1.5 HP (1.1 kW)	2 HP (1.5 kW)	3 HP (2.2 kW)
Room temperature	0 °C ÷ 40 °C	0 °C ÷ 40 °C	0 °C ÷ 40 °C
Protection rating	IP 54	IP 54	IP 54
RS-485 communication	standard	standard	standard
Dry input contact	standard	standard	standard
Dry contact output	standard	standard	standard

ELECTRICAL PANEL

The keypad simplifies the process of accessing and navigating configuration menus, enabling the adjustment, and monitoring of various operational parameters, including system pressure, operating frequency, absorbed current, and alarm messages. LED indicators provide quick insights into the pump's operational status at a glance.

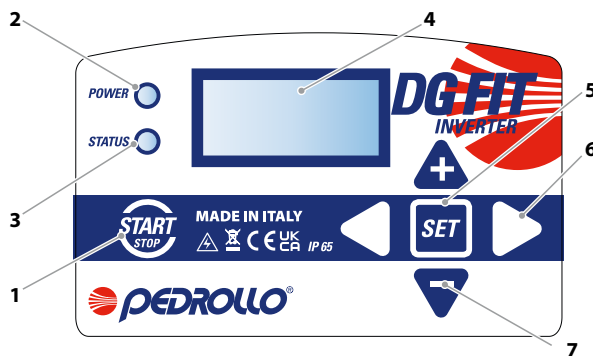

KEY

- | | |
|-----------------------|---------------------------------------|
| 1) Power on/off key | 5) SET button |
| 2) Red networking LED | 6) Menu/parameter input/output arrows |
| 3) Green run LED | 7) Menu/parameter scrolling arrows |
| 4) Display | |

DIMENSIONS (mm)

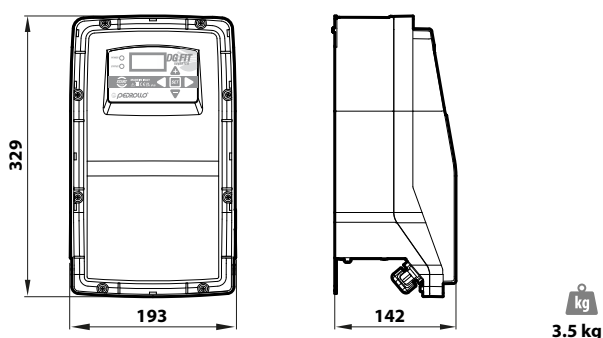

TYPICAL INSTALLATION

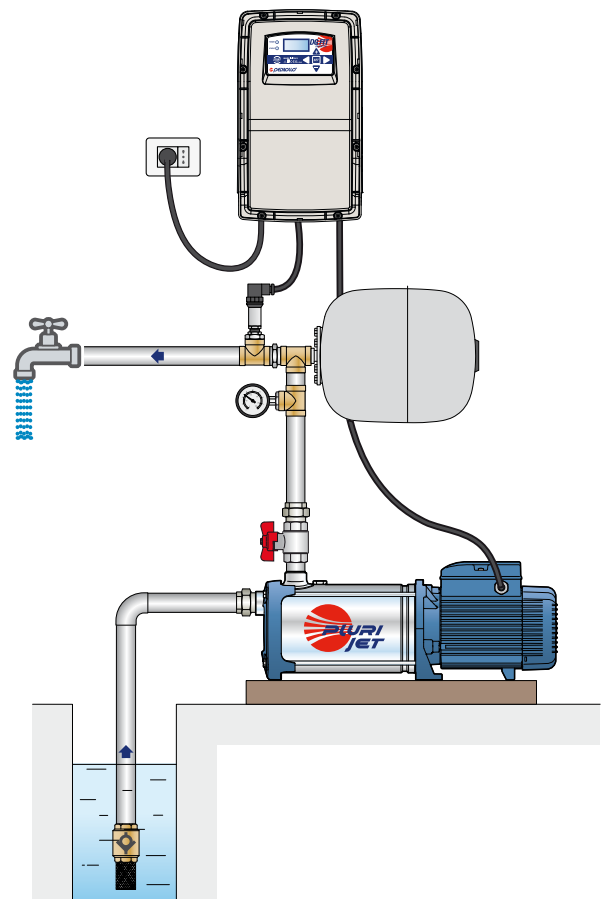

N.B.: it's neceadvisable to install a membrane EXPANSION TANK downstream of the inverter to:

- ✘ decrease pump start frequency
- ✘ absorb excess pressure from the system, like water hammer



INSTALLATION AND USE

PRO-DG is an inverter-based electronic control device compatible with both surface and submersible pumps, with motor powers of up to 15 HP. It is specifically engineered for professional applications in water supply, distribution, and transportation across commercial, industrial, and agricultural sectors.

Additionally, **PRO-DG** seamlessly integrates with all types of pressurization systems, including existing setups, ensuring enhanced comfort, prolonged system lifespan, and significant energy savings.

PRO-DG protects the pump from:

- ✘ Dry running
- ✘ Overcurrent
- ✘ Overheating
- ✘ Lack of phases in connections (for TT versions)
- ✘ Motor faults

PRODUCT DESCRIPTION

PRO-DG is a frequency inverter to be installed on the wall using the **WALL MOUNT SUPPORT** installation kit, which includes a ventilation system to induce forced cooling of the electronic components.

Connected to an appropriate pressure sensor, **PRO-DG** adjusts the motor rotation speed to be varied according to water demand and maintains a constant pressure in the system for greater comfort and energy savings.

PRO-DG features include:

- RS485 communication facilitates the connection of up to 8 devices and the creation of pumping groups comprising multiple pumps of the same type.
- a display and keypad enable straightforward and intuitive configuration of basic operating parameters through a start-up wizard consisting of a few simple steps.

KEY FEATURES

- ✘ Easy programming and adjustment
- ✘ Constant pressure in the system
- ✘ Energy Conservation
- ✘ Reduced noise operation
- ✘ Compatible with all pumps on the market
- ✘ Communication of up to eight devices
- ✘ Intelligent intervention management in case of anomalies

OPTIONAL A RICHIESTA

- ✘ An expansion board can be connected to the MT2-11 and TT3-11 models (standard in the TT3-30 model), providing the following capabilities:
 - connect to monitoring systems with ModBus connection;
 - take a differential pressure reading by connecting a second pressure transducer.

TECHNICAL DATA	PRO-DG MT2-11A	PRO-DG TT3-11A	PRO-DG TT3-30A
Power supply voltage	1 ~ 230 V	3 ~ 400 V	3 ~ 400 V
Pump motor voltage	3 ~ 230 V	3 ~ 400 V	3 ~ 400 V
Permissible voltage variation	± 10%	± 10%	± 10%
Supply frequency	50/60Hz	50/60Hz	50/60Hz
Maximum inverter input current	20 A	12 A	31 A
Maximum electric pump motor current	11 A	11 A	30 A
Maximum electric pump motor power	3 HP	5.5 HP	15 HP
Room temperature	-10 °C ÷ 40 °C	-10 °C ÷ 40 °C	-10 °C ÷ 40 °C
Protection rating	IP 55*	IP 55*	IP 55*
No. of 4-20 mA inputs	1	1	2
No. of configurable digital inputs	2	2	4
RS485 Communication	standard	standard	standard
Motor temperature probe input	optional	optional	standard
0-10 V input	optional	optional	standard
Modbus communication	optional	optional	standard

* IP 54 degree of protection when using the "WALL MOUNT SUPPORT" accessory for wall installation

ELECTRICAL PANEL

The keypad simplifies the process of accessing and navigating configuration menus, enabling the adjustment, and monitoring of various operational parameters, including system pressure, operating frequency, absorbed current, and alarm messages. LED indicators provide quick insights into the pump's operational status at a glance

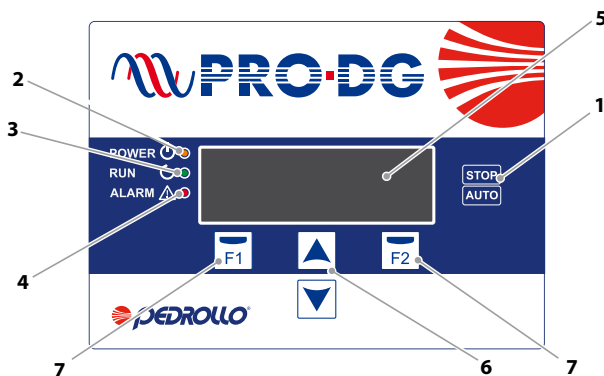

KEY

- | | |
|-----------------------------|-------------------|
| 1) Manual switch-off button | 5) Display |
| 2) Networking LED | 6) Scroll Arrows |
| 3) Running LEDs | 7) FUNCTION KEYS. |
| 4) Alarm LED | |

DIMENSIONS (mm)

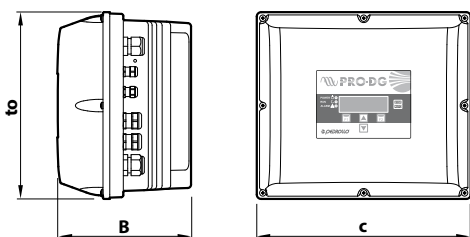

TYPE	DIMENSIONS mm			kg
	a	b	c	
PRO-DG MT 2-11A	183	149	230	2.8
PRO-DG TT 3-11A	183	149	230	2.8
PRO-DG TT 3-30A	276	198	316	6.4

TYPICAL INSTALLATION

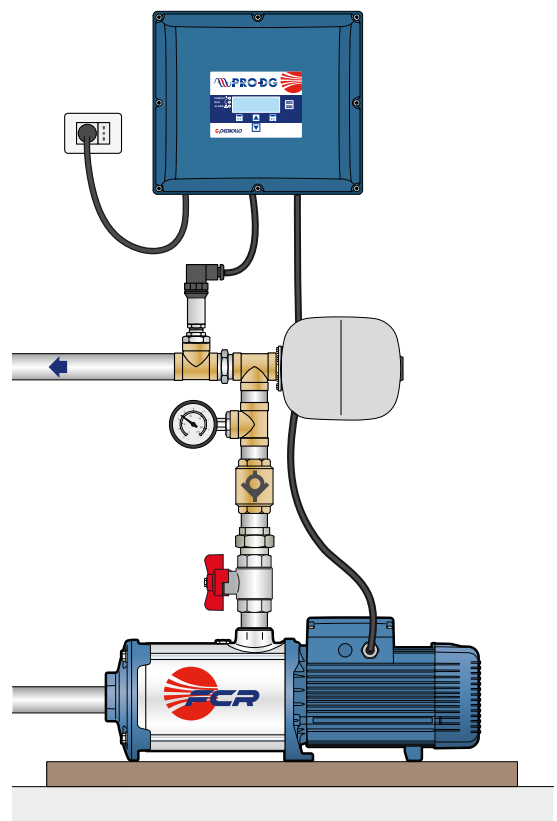

PRO-DG is designed for wall-mounting exclusively when fitted with the WALL MOUNT SUPPORT, available for separate purchase

-  Domestic use
-  Civil use
-  Industrial use
-  Agricultural use

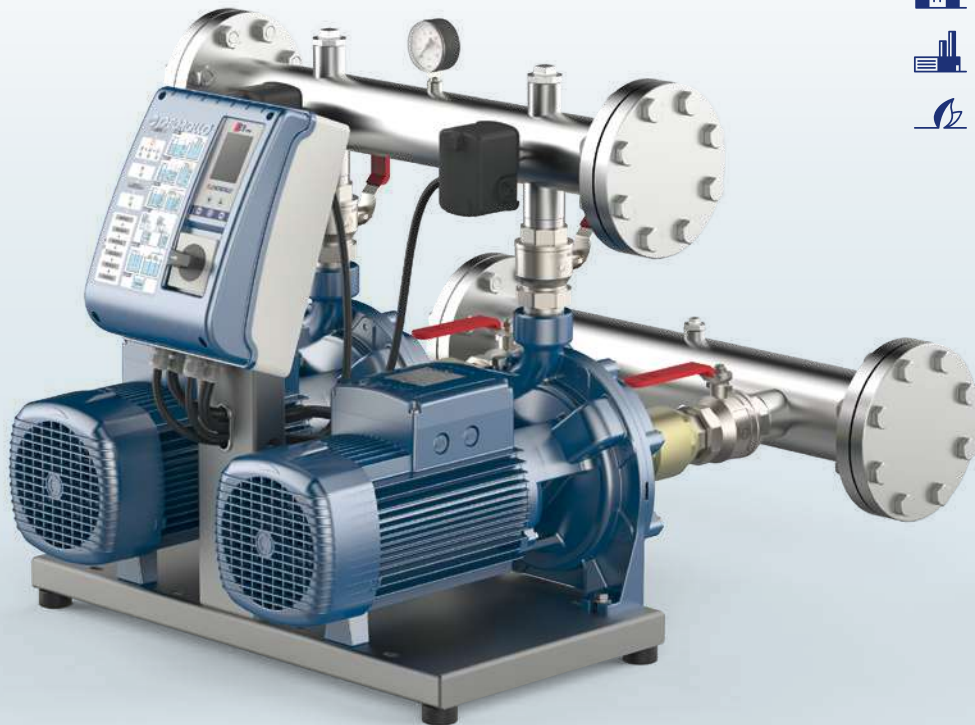

INSTALLATION AND USE

CB2 is a pre-assembled pumping system comprising two pumps, designed for water supply and pressurization in residential, commercial, public buildings, hotels, hospitals, as well as for garden and agricultural irrigation.

CB2 is suitable for pumping clean water or aqueous solutions that do not chemically or mechanically damage the materials used and do not contain abrasive or fibrous substances.

PRODUCT DESCRIPTION

CB2 is a pressurization system featuring two pumps assembled in a unit, ready for connection to the water mains or a primary collection tank.

Controlled by mechanical pressure switches, **CB2** ensures automatic activation of one or both pumps in response to increased user demand, optimizing water supply and minimizing electricity consumption. The system's electronic circuitry facilitates automatic pump switching during start/stop cycles and provides protection against potential faults.

COMPONENTS

- ※ **Pumps** connected in parallel via suction and discharge manifolds. Each unit is equipped with ball valves on the discharge and suction side, non-return valves on the suction side (with 2CP, 3-5CR, FCR, MK pumps) or on the discharge side (with HT pumps).
- ※ **BASE** made of metal profile and fitted with adjustable vibration-damping feet.
- ※ **PRESSURE SWITCHES** mounted on the delivery manifold and connected to the electrical panel for switching the pumps on and off according to regulation.
- ※ **ELECTRONIC ELECTRICAL PANEL** (model **E2**) provides protection against dry running by monitoring electrical parameters and allows advanced users to adjust settings to tailor the operation of the pressure unit to specific system requirements.
- ※ Power supply:
 - **CB2m**: single-phase 230 V - 50 Hz
 - **CB2**: three-phase 400 V - 50 Hz



CB2 – 2CP

Pressurization units comprising two twin impeller centrifugal pumps, designed to enhance water pressure. Ideal for both residential and commercial water supply applications, they are well-suited for large-scale garden and agricultural irrigation. They also excel at handling clean water in various industrial settings.

TECHNICAL DATA

- Liquid temperature between **+5 °C** and **+55 °C**
- Ambient temperature between **+5 °C** and **+40 °C**
- Max. pressure in the pump body **10 bar** (6 bar for 2CP25/130)
- Continuous running duty **S1**



CB2 – 3-5CR

Pressurization units comprising two multistage centrifugal pumps. They are well-suited for domestic water supply, garden irrigation, and general clean water handling.

TECHNICAL DATA

- Liquid temperature between **+5 °C** and **+55 °C**
- Ambient temperature between **+5 °C** and **+40 °C**
- Max. pressure in the pump body **7 bar**
- Continuous running duty **S1**



CB2 – FCR

Pressurization units comprising two horizontal multistage centrifugal pumps.

Especially well-suited for residential and commercial water supply, industrial pressure boosting, and garden and field irrigation.

TECHNICAL DATA

- Liquid temperature between **+5 °C** and **+55 °C**
- Ambient temperature between **+5 °C** and **+40 °C**
- Max. pressure in pump body **11 bar** (for FCR 80-100 7 bar)
- Continuous running duty **S1**



CB2 – MK

Pressurization units comprising two vertical multistage centrifugal pumps.

They are suitable for residential and commercial water supply, garden irrigation and general clean water handling.

TECHNICAL DATA

- Liquid temperature between **+5 °C** and **+55 °C**
- Ambient temperature between **+5 °C** and **+40 °C**
- Max. pressure in pump body **11 bar**
- Continuous running duty **S1**



CB2 – HT

Pressurization units comprising two vertical multistage centrifugal pumps.

They are well-suited for residential and commercial water supply, irrigation, and general clean water handling, including industrial applications

TECHNICAL DATA

- Liquid temperature between **+5 °C** and **+55 °C**
- Ambient temperature between **+5 °C** and **+40 °C**
- Max. pressure in the pump body **16 bar**
- Continuous running duty **S1**

CB2 – 2CP

FIELD AND PERFORMANCE DATA

50 Hz

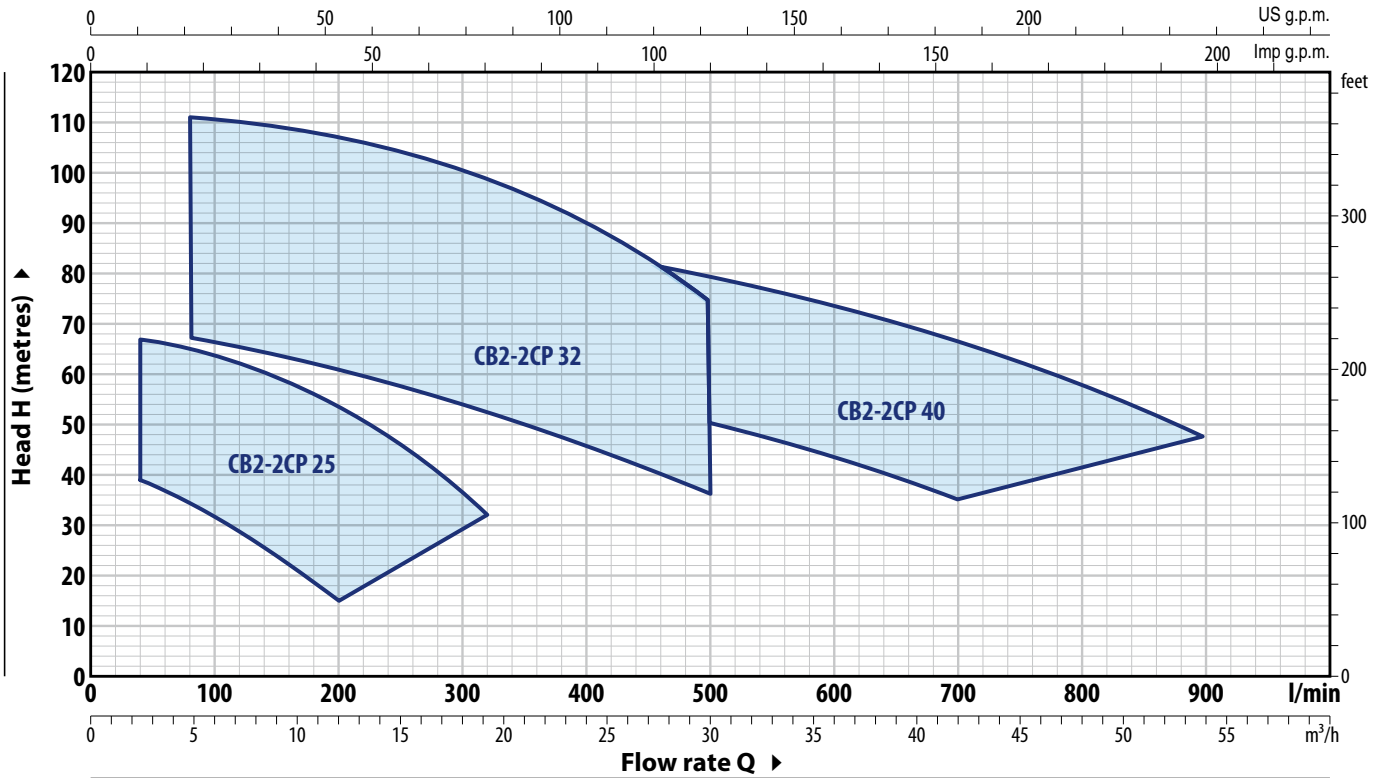

TYPE		POWER P ₂		Q	m ³ /h											
Single-phase	Three-phase	kW	HP		0	2.4	4.8	7.2	9.6	10.8	12.0	13.2	14.4	16.8	19.2	
CB2 - 2CPm 25/130	–	2x0.75	2x1	H metres	0	40	80	120	160	180	200	220	240	280	320	
CB2 - 2CPm 25/14B	CB2 - 2CP 25/14B	2x1.1	2x1.5		42	39	34.5	28.5	22	18	15					
CB2 - 2CPm 25/16C	CB2 - 2CP 25/16C	2x1.1	2x1.5		54	52	47.5	41	32.5	27.5	22					
CB2 - 2CPm 25/16B	CB2 - 2CP 25/16B	2x1.5	2x2		47	46	44	40.5	36	33.5	30.5	27.5	24			
–	CB2 - 2CP 25/16A	2x2.2	2x3		58	56	54	51	47.5	45.5	43	40	37	30		
					68	67	65	62	58.5	56	54	51	48	40.5	32	

TYPE		POWER P ₂		Q	m ³ /h										
Single-phase	Three-phase	kW	HP		0	4.8	7.2	9.6	12.0	14.4	16.8	19.2	21.6	24.0	30.0
–	CB2 - 2CP 32/200C	2x3	2x4	H metres	0	80	120	160	200	240	280	320	360	400	500
–	CB2 - 2CP 32/200B	2x4	2x5.5		70	67	65	63	60.5	58	55	52	48.5	45.5	36
–	CB2 - 2CP 32/210B	2x5.5	2x7.5		85	81	79	77	74.5	71.5	69	66	62.5	59	49
–	CB2 - 2CP 32/210A	2x7.5	2x10		94	94	93	91	89	86	83	79	75	70	56
					112	111	110	109	107	105	102	99	95	90	74

TYPE		POWER P ₂		Q	m ³ /h									
Single-phase	Three-phase	kW	HP		0	12	18	24	30	36	42	48	54	
–	CB2 - 2CP 40/180C	2x4	2x5.5	H metres	0	200	300	400	500	600	700	800	900	
–	CB2 - 2CP 40/180B	2x5.5	2x7.5		65	63	60	55.5	50	43	35			
–	CB2 - 2CP 40/180A	2x7.5	2x10		80	78	75	71	65.5	59	51	42		
					92	90	87.5	84	79	73.5	66	58	48	

Q = Flow rate H = Total manometric head

Performance curves comply with EN ISO 9906 Grade 3B tolerance limits.

✘ The data shown in the diagram and tables indicate performance with 2 pumps in operation

PERFORMANCE CURVES

50 Hz

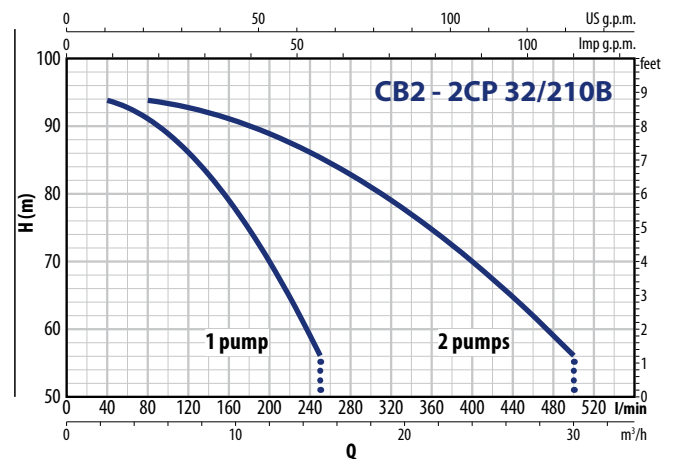
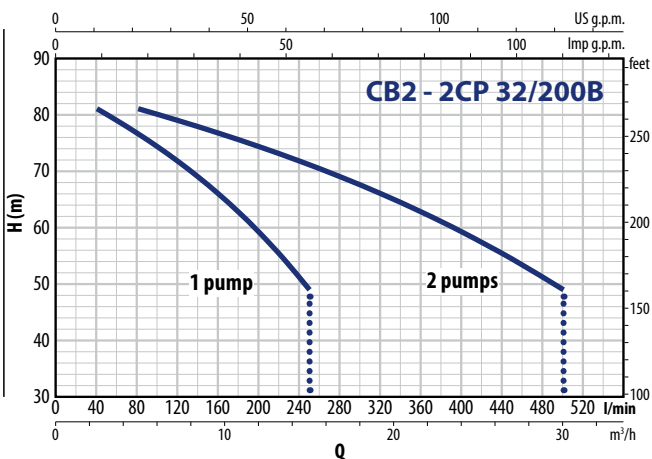
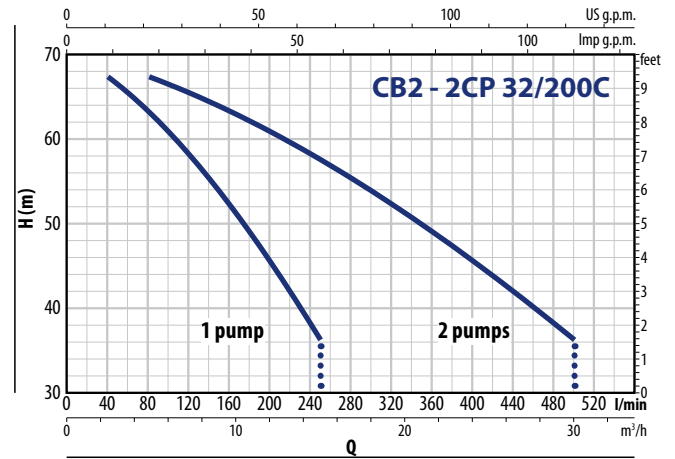
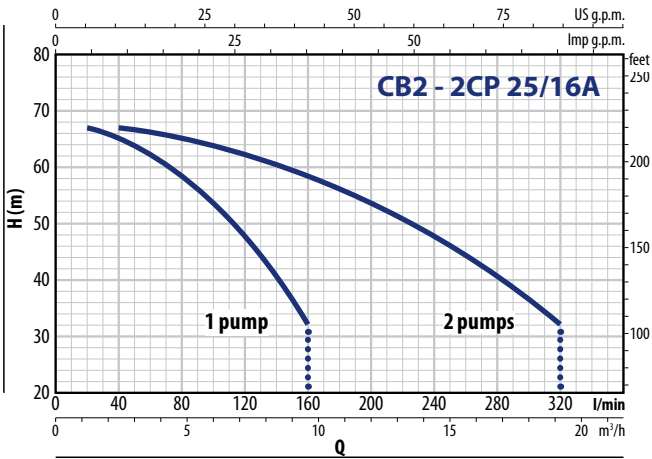
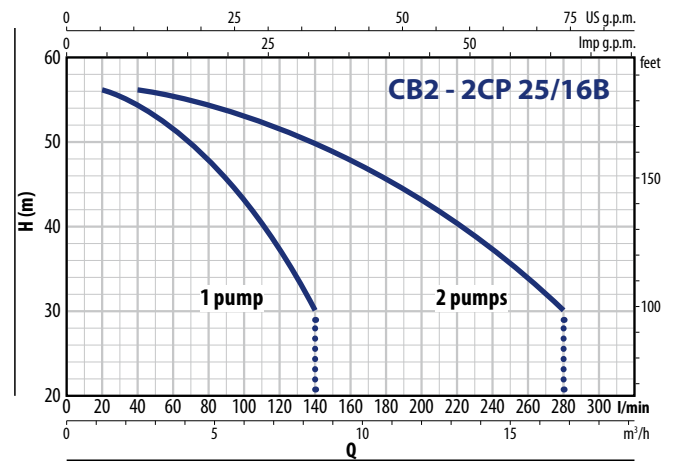
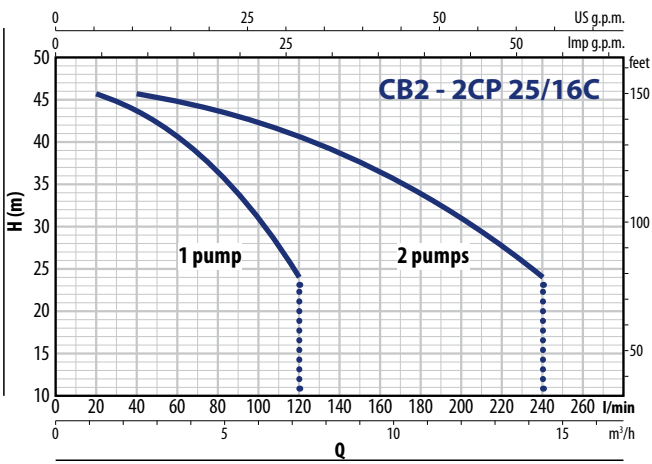
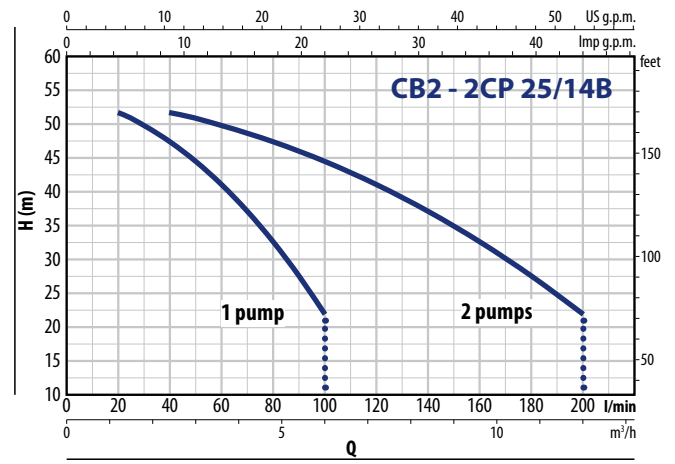
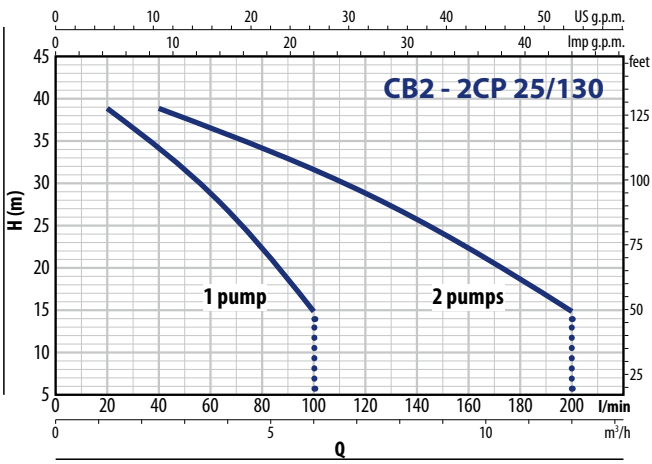

CB2 - 2CP

PERFORMANCE CURVES

50 Hz

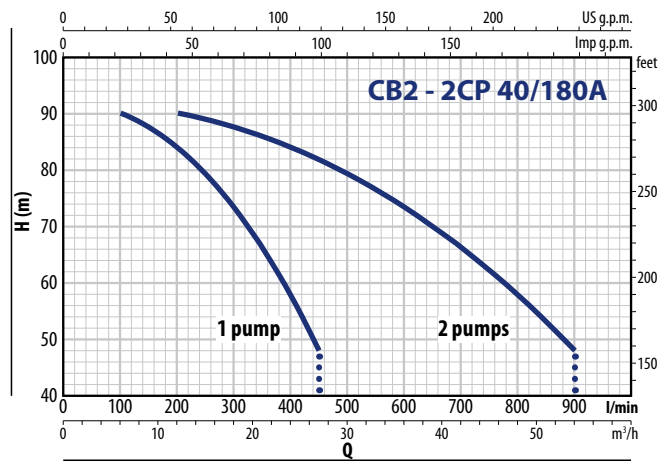
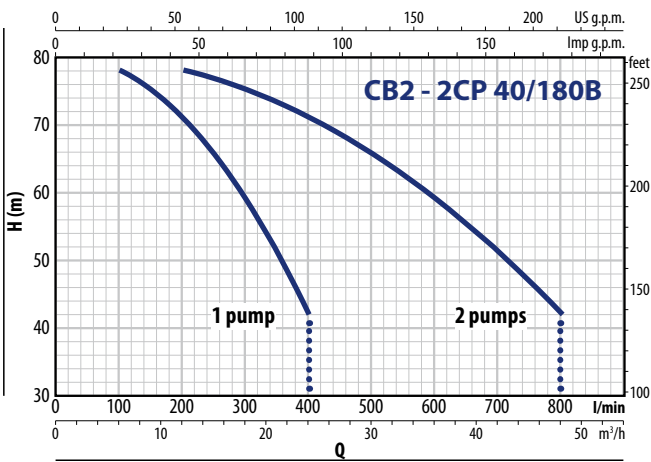
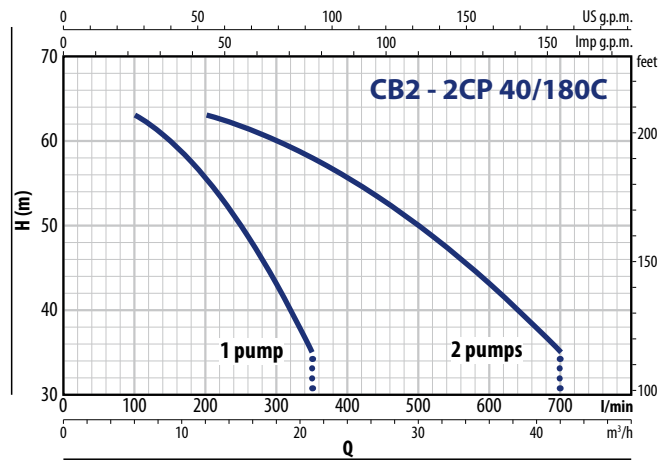
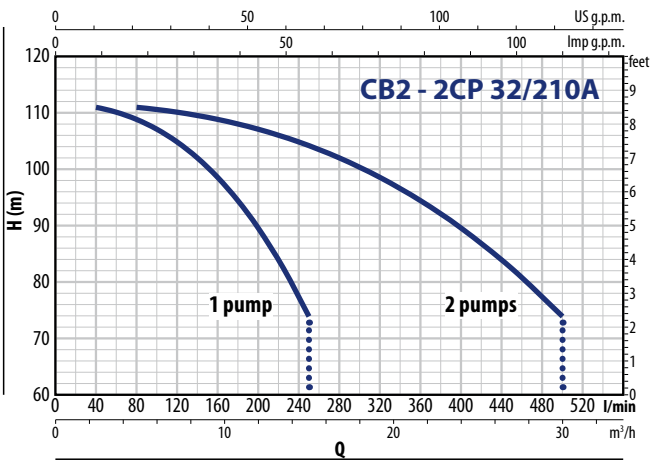

ABSORPTION

TYPE	VOLTAGE
Single-phase	230 V
CB2 - 2CPm 25/130	2 x 6.3 A
CB2 - 2CPm 25/14B	2 x 7.7 A
CB2 - 2CPm 25/16C	2 x 7.7 A
CB2 - 2CPm 25/16B	2 x 10.0 A

TYPE	VOLTAGE
Three-phase	400 V
CB2 - 2CP 25/14B	2 x 3.1 A
CB2 - 2CP 25/16C	2 x 3.1 A
CB2 - 2CP 25/16B	2 x 4.0 A
CB2 - 2CP 25/16A	2 x 5.3 A
CB2 - 2CP 32/200C	2 x 7.4 A
CB2 - 2CP 32/200B	2 x 10.5 A
CB2 - 2CP 32/210B	2 x 12.5 A
CB2 - 2CP 32/210A	2 x 16.0 A
CB2 - 2CP 40/180C	2 x 9.8 A
CB2 - 2CP 40/180B	2 x 12.3 A
CB2 - 2CP 40/180A	2 x 15.4 A

DIMENSIONS AND WEIGHT

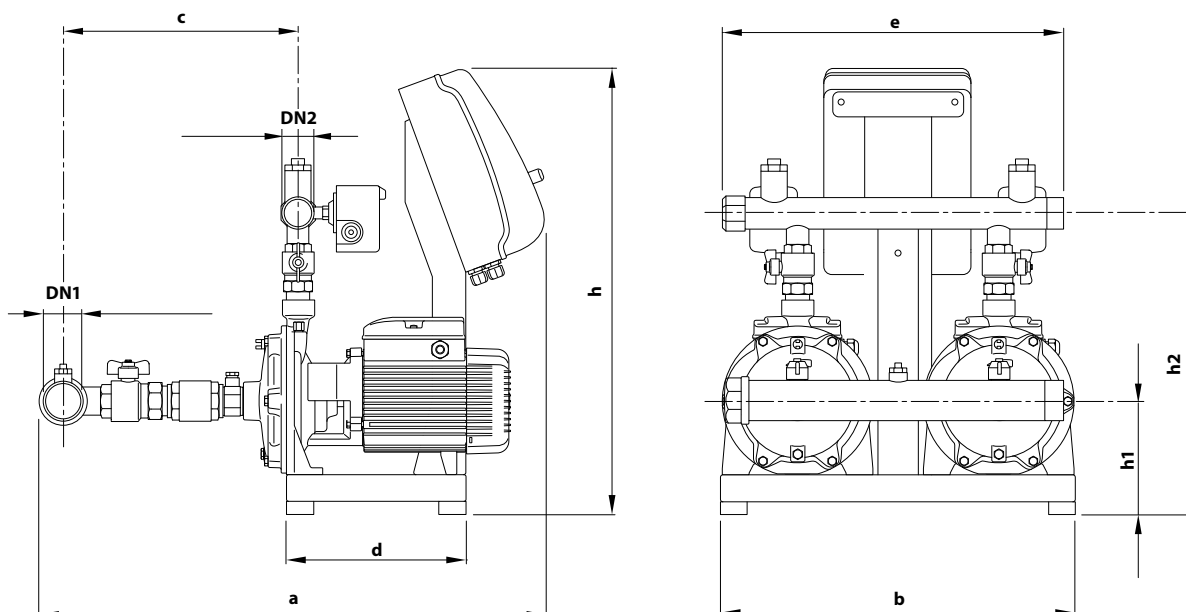

TYPE		PORTS		DIMENSIONS mm								kg			
Single-phase	Three-phase	DN1	DN2	a	b	c	d	e	h	h1	h2	1~	3~		
CB2 - 2CPm 25/130	–	2"	1½"	727	530	337	270	510	674	152	390	60.0	–		
CB2 - 2CPm 25/14B	CB2 - 2CP 25/14B			752		453				153	413	72.0	73.0		
CB2 - 2CPm 25/16C	CB2 - 2CP 25/16C			761		456				170	451	73.0	73.0		
CB2 - 2CPm 25/16B	CB2 - 2CP 25/16B			761		456				170	451	80.0	80.0		
–	CB2 - 2CP 25/16A	3"	2"	972	700	456	370	712	674	192	516	–	129.0		
–	CB2 - 2CP 32/200C			977						456	546	–	161.0		
–	CB2 - 2CP 32/200B			977						456	546	–	171.0		
–	CB2 - 2CP 32/210B			977						456	546	–	171.0		
–	CB2 - 2CP 32/210A	DN 100 4"	DN 80 3"	1048	700	468	370	712	674	199	590	–	190.0		
–	CB2 - 2CP 40/180C			1048						468	774	716	590	–	199.0
–	CB2 - 2CP 40/180B			1048						468	774	716	590	–	199.0
–	CB2 - 2CP 40/180A	1048	468	774	716	590	–	211.0							

CB2 – 4-5CR

FIELD AND PERFORMANCE DATA

50 Hz

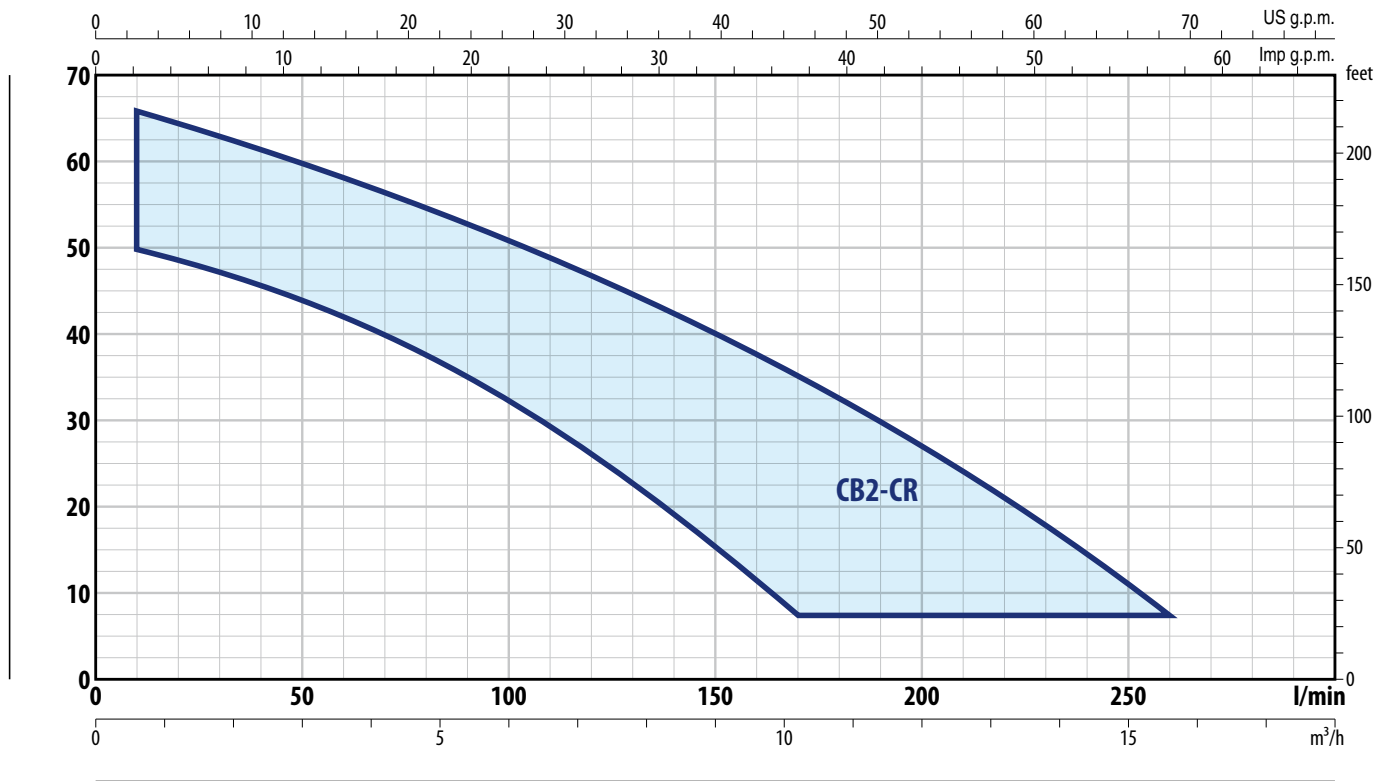

TYPE		POWER (P ₂)		Q	m ³ /h															
Single-phase	Three-phase	kW	HP		0	0.6	1.2	2.4	3.6	4.8	6	7.2	8.4	9.6	10.8	12	13.2	14.4	15.6	
				l/min	0	10	20	40	60	80	100	120	140	160	180	200	220	240	260	
CB2 - 5CRm 80	CB2 - 5CR 80	2x0.75	2x1	H metres	67	66	64	59	53	45.5	37.5	29.5	20.5	12						
CB2 - 4CRm 100	CB2 - 4CR 100	2x0.75	2x1		50	50	49	47	45	42	39.5	37	34	30.5	26.5	22	17	11	5	
CB2 - 5CRm 100	CB2 - 5CR 100	2x0.90	2x1.25		63	62	61.5	59.5	57	53.5	50.5	46.5	42.5	38	33	28	22	15	8	

Q = Flow rate H = Total manometric head

Performance curves comply with EN ISO 9906 Grade 3B tolerance limits.

✳ The data shown in the diagram and tables indicate performance with 2 pumps in operation

ABSORPTION

TYPE	VOLTAGE
Single-phase	230 V
CB2 - 5CRm 80	2 x 5.5 A
CB2 - 4CRm 100	2 x 5.8 A
CB2 - 5CRm 100	2 x 6.8 A

TYPE	VOLTAGE
Three-phase	400 V
CB2 - 5CR 80	2 x 2.5 A
CB2 - 4CR 100	2 x 2.3 A
CB2 - 5CR 100	2 x 2.5 A

PERFORMANCE CURVES

50 Hz

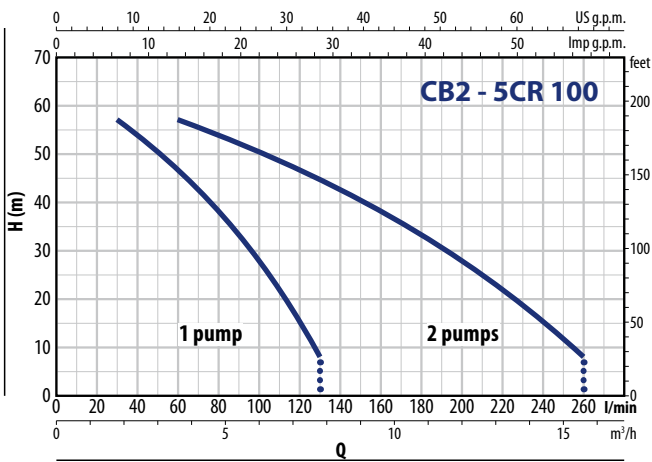
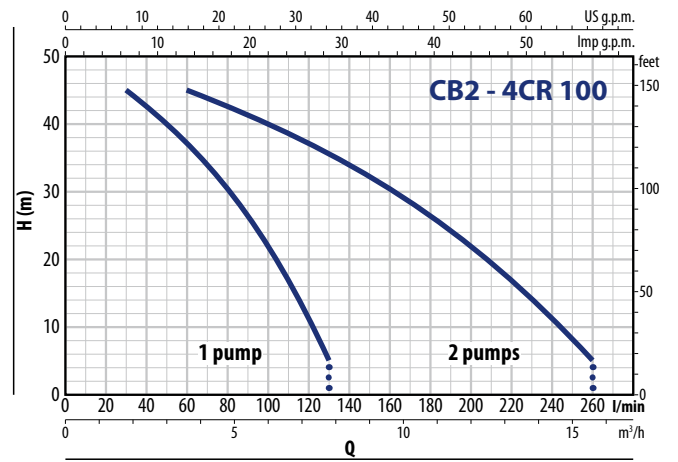
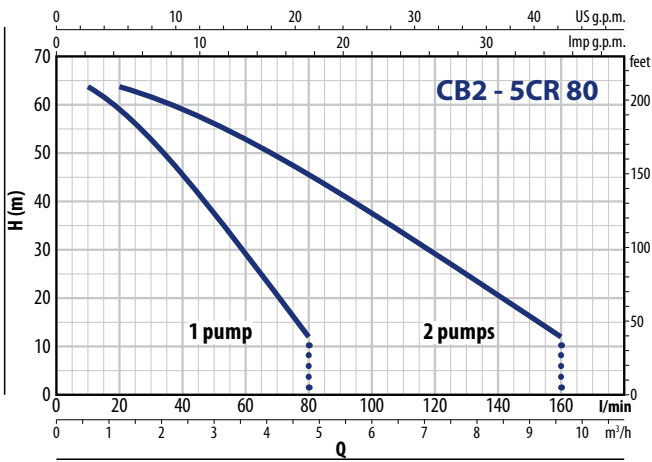

DIMENSIONS AND WEIGHT

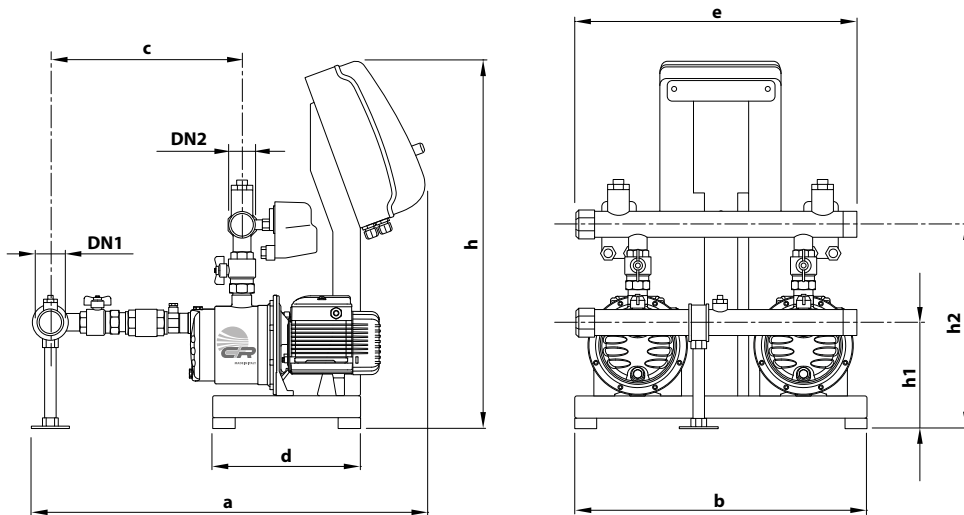

TYPE		PORTS		DIMENSIONS mm								kg	
Single-phase	Three-phase	DN1	DN2	a	b	c	d	e	h	h1	h2	1~	3~
CB2 - 5CRm 80	CB2 - 5CR 80	1½"	1½"	760	530	370	270	510	674	192	373	53	54
CB2 - 4CRm 100	CB2 - 4CR 100	2"	1½"	803	530	408	270	510	674	192	373	54	55
CB2 - 5CRm 100	CB2 - 5CR 100											56	55

CB2 – FCR

FIELD AND PERFORMANCE DATA

50 Hz

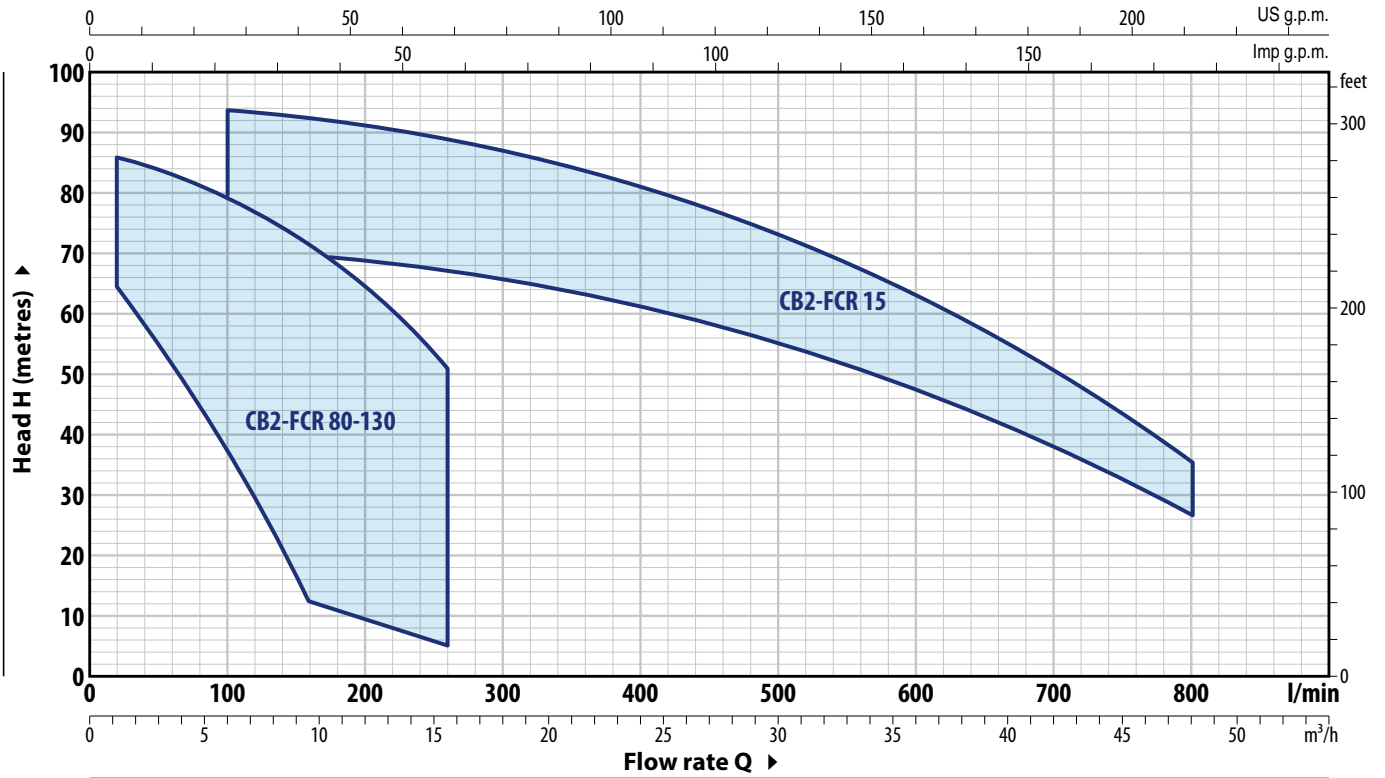

TYPE		POWER P ₂		Q	H metres														
Single-phase	Three-phase	kW	HP		m³/h	0	0.6	1.2	2.4	4.8	7.2	9.6	10.8	12	13.2	14.4	15.6		
				l/min	0	10	20	40	80	120	160	180	200	220	240	260			
CB2 - FCRm 80/5	–	2x0.75	2x1	H metres	67	66	64	59	45.5	29.5	12								
CB2 - FCRm 100/4	–	2x0.75	2x1		50	50	49	47	42	37	30.5	26.5	22	17	11	5			
CB2 - FCRm 100/5	CB2 - FCR 100/5	2x1.1	2x1.5		63	62	61.5	59.5	53.5	46.5	38	33	28	22	15	8			
CB2 - FCRm 90/5	CB2 - FCR 90/5	2x1.1	2x1.5		81	80	79	77	71	62.5	51	44							
CB2 - FCRm 130/4	CB2 - FCR 130/4	2x1.5	2x2		68.5	68.5	68	67	65	62	57.5	55	52	48	45	41			
–	CB2 - FCR 130/5	2x1.8	2x2.5		86	85	85	84	81	77	72	68.5	65	73	67	51.5			

TYPE		POWER P ₂		Q	H metres						
Single-phase	Three-phase	kW	HP		m³/h	0	6	12	24	36	42
				l/min	0	100	200	400	600	700	800
–	CB2 - FCR 15/3	2x4	2x5.5	H metres	72	70	68.5	61	48	38.5	27
–	CB2 - FCR 15/4	2x5.5	2x7.5		96	94	91	81	64	51.5	36

Q = Flow rate H = Total manometric head

Performance curves comply with EN ISO 9906 Grade 3B tolerance limits.

✘ The data shown in the diagram and tables indicate performance with 2 pumps in operation

PERFORMANCE CURVES

50 Hz

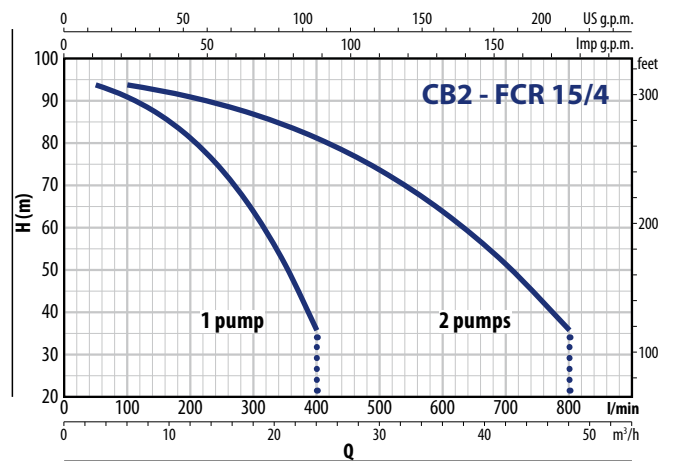
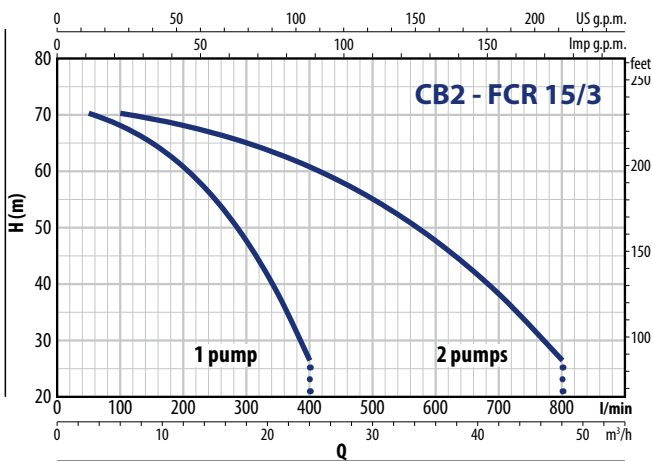
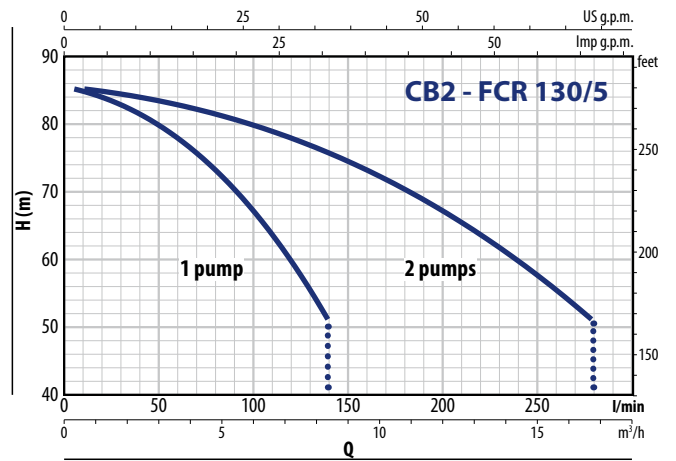
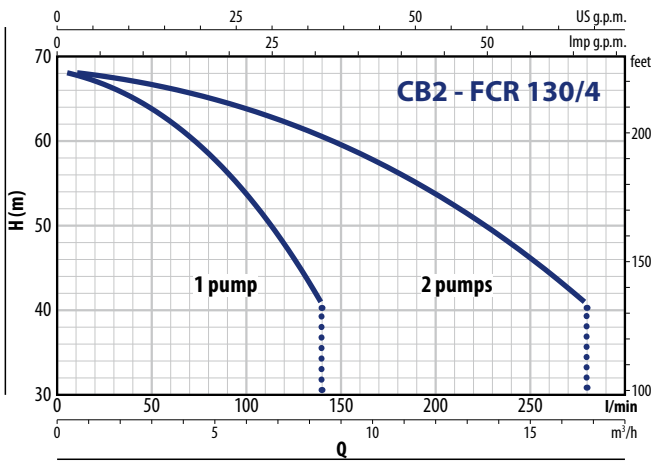
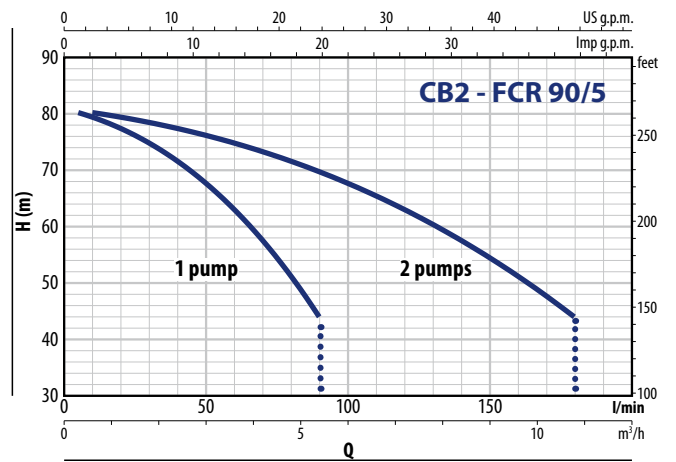
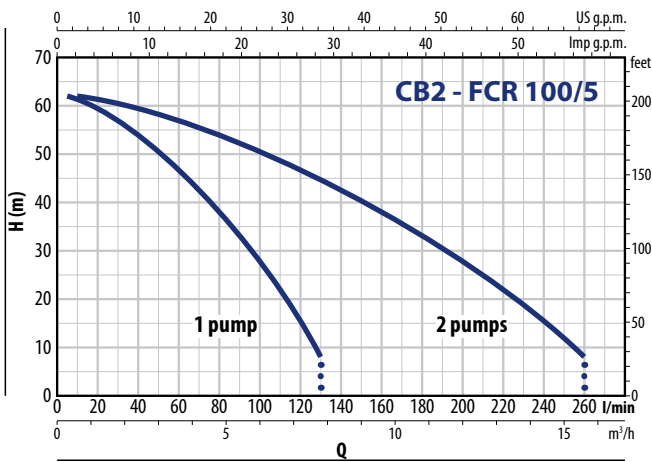
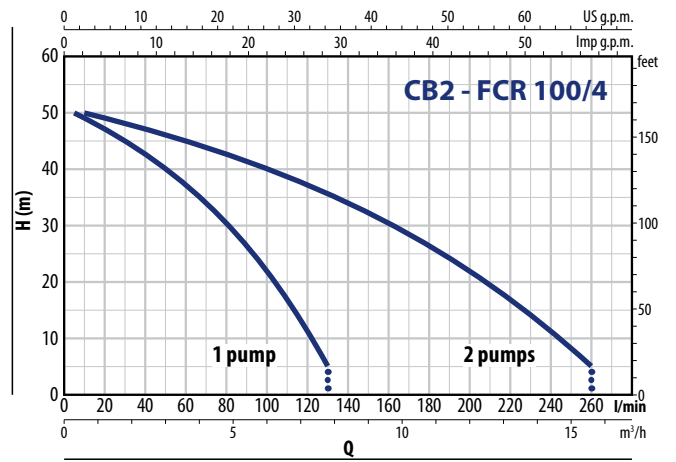
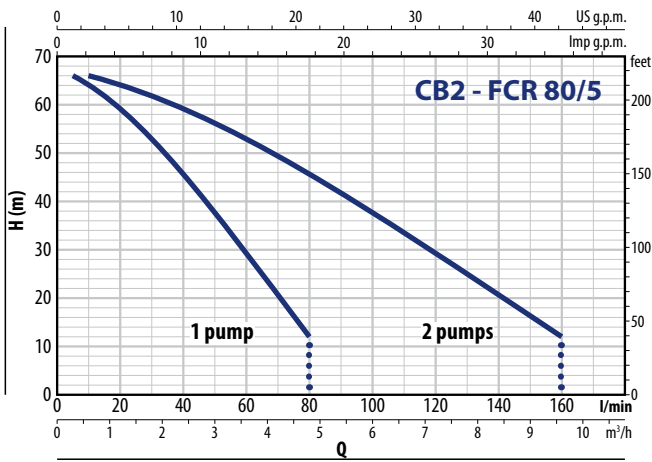

CB2 – FCR

ABSORPTION

TYPE	VOLTAGE
Single-phase	230 V
CB2 - FCRm 80/5	2 x 5.5 A
CB2 - FCRm 100/4	2 x 5.8 A
CB2 - FCRm 100/5	2 x 6.8 A
CB2 - FCRm 90/5	2 x 9.0 A
CB2 - FCRm 130/4	2 x 10.3 A

TYPE	VOLTAGE
Three-phase	400 V
CB2 - FCR 100/5	2 x 2.5 A
CB2 - FCR 90/5	2 x 3.5 A
CB2 - FCR 130/4	2 x 4.0 A
CB2 - FCR 130/5	2 x 5.0 A
CB2 - FCR 15/3	2 x 8.8 A
CB2 - FCR 15/4	2 x 11.2 A

DIMENSIONS AND WEIGHT

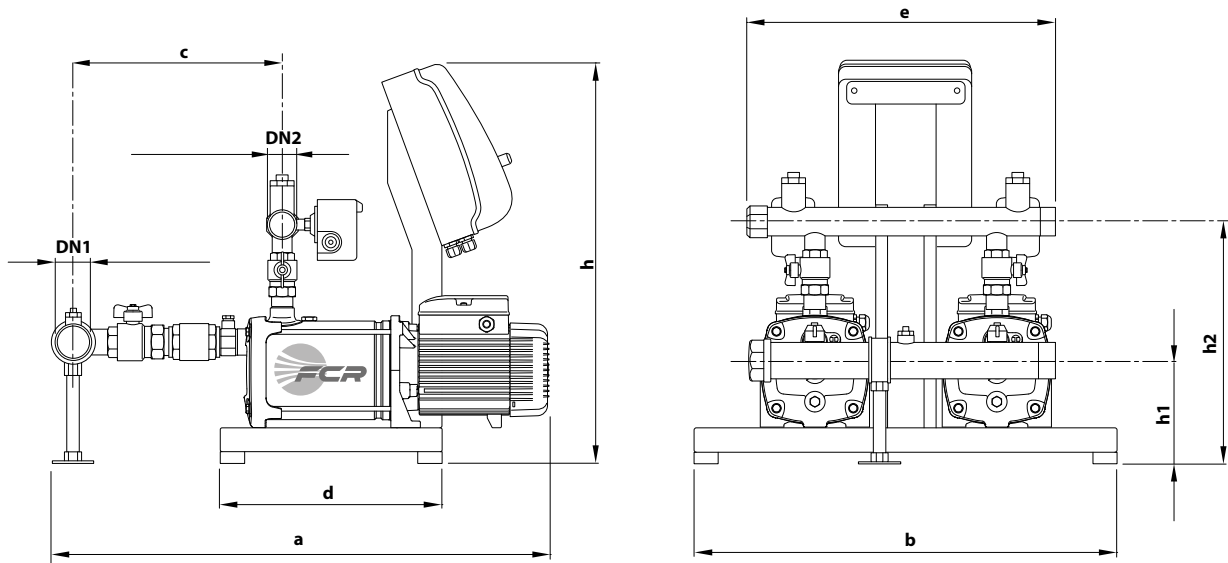

TYPE		PORTS		DIMENSIONS mm								kg	
Single-phase	Three-phase	DN1	DN2	a	b	c	d	e	h	h1	h2	1~	3~
CB2 - FCRm 80/5	–	1½"	1½"	672		364						53	–
CB2 - FCRm 100/4	–			715	530	401	270			182	368	56	–
CB2 - FCRm 100/5	CB2 - FCR 100/5							510	674			56	56
CB2 - FCRm 90/5	CB2 - FCR 90/5	2"	1½"	805								82	83
CB2 - FCRm 130/4	CB2 - FCR 130/4			779	700	339	370			205	394	82	83
–	CB2 - FCR 130/5			805								–	90
–	CB2 - FCR 15/3	DN 100	DN 80	1058		569	490	774	704	211	565	–	179
–	CB2 - FCR 15/4	4"	3"	1102	700	613						–	191

FIELD AND PERFORMANCE DATA

50 Hz

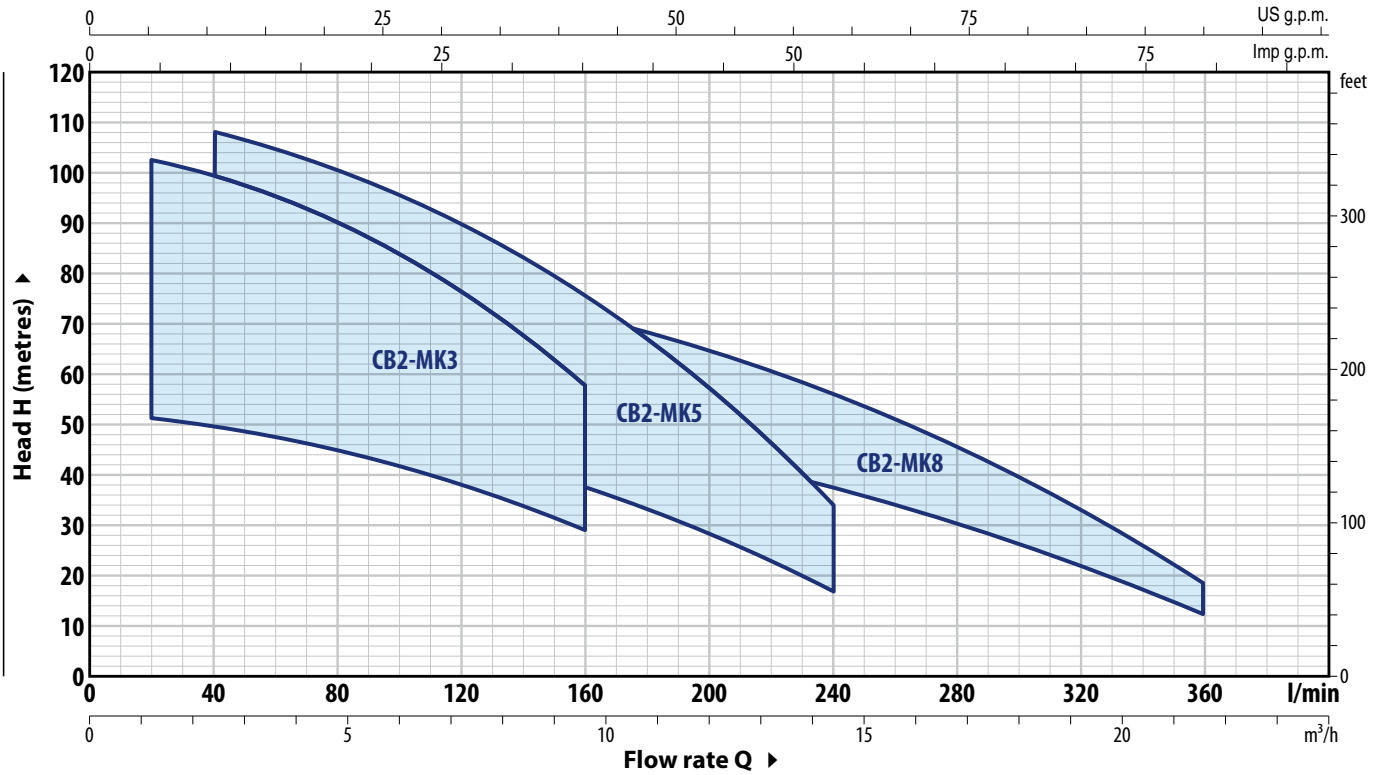

TYPE		POWER P ₂		Q	H metres												
Single-phase	Three-phase	kW	HP		m ³ /h	0	1.2	2.4	4.8	7.2	9.6	12.0	14.4	16.8	19.2	21.6	
				l/min	0	20	40	80	120	160	200	240	280	320	360		
CB2 - MKm 3/3	CB2 - MK 3/3	2x0.75	2x1	H metres	52.5	51.5	50	45	38.5	29							
CB2 - MKm 3/5	CB2 - MK 3/5	2x1.1	2x1.5		87	85	83	75	64	48							
CB2 - MKm 3/6	CB2 - MK 3/6	2x1.5	2x2		105	103	100	90	77	58							
CB2 - MKm 5/4	CB2 - MK 5/4	2x0.75	2x1		57	-	54	50	45	37.5	28.5	17					
CB2 - MKm 5/5	CB2 - MK 5/5	2x1.1	2x1.5		71	-	67.5	62.5	56	47	35.5	21.5					
CB2 - MKm 5/7	CB2 - MK 5/7	2x1.5	2x2		99	-	95	88	78	66	50	30					
CB2 - MKm 5/8	CB2 - MK 5/8	2x2.2	2x3		114	-	108	100	90	75	57	34					
CB2 - MKm 8/4	CB2 - MK 8/4	2x1.1	2x1.5		56	-	-	53.5	51	47.5	43	37.5	30.5	22.1	12		
CB2 - MKm 8/5	CB2 - MK 8/5	2x1.5	2x2		70	-	-	67	64	59.5	54	47	38	27.5	15.5		
CB2 - MKm 8/6	CB2 - MK 8/6	2x2.2	2x3		84	-	-	80	77	72	64.5	56	45.5	33	18.5		

Q = Flow rate H = Total manometric head

Performance curves comply with EN ISO 9906 Grade 3B tolerance limits.

✳ The data shown in the diagram and tables indicate performance with 2 pumps in operation

CB2 - MK

PERFORMANCE CURVES

50 Hz

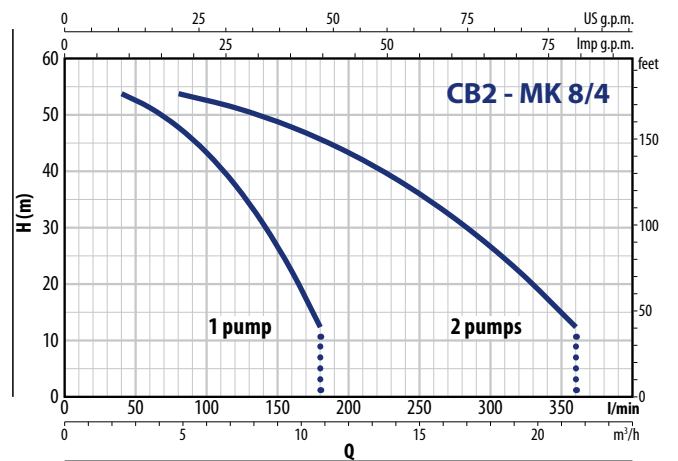
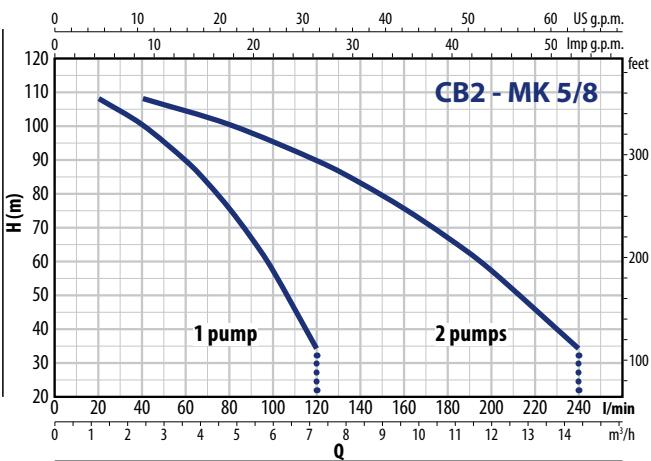
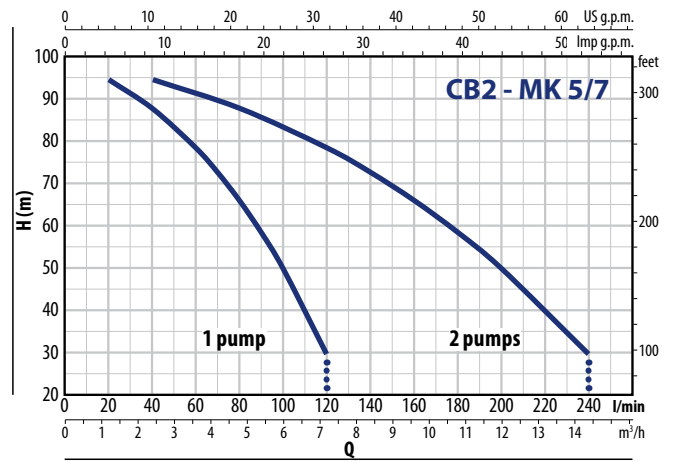
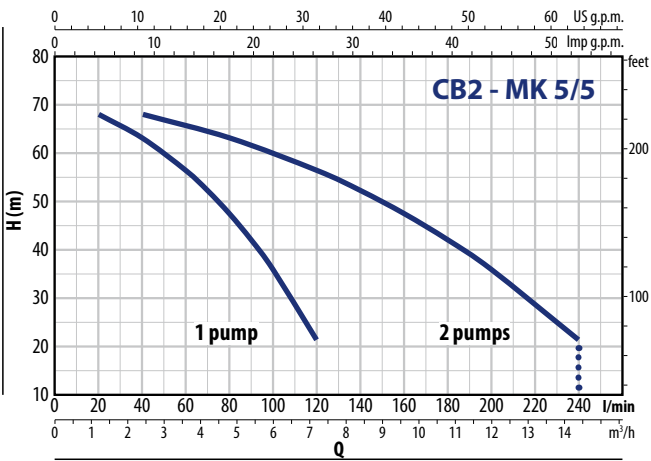
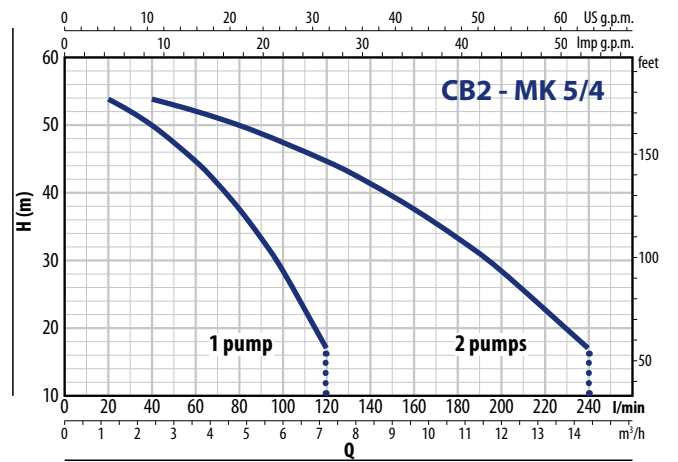
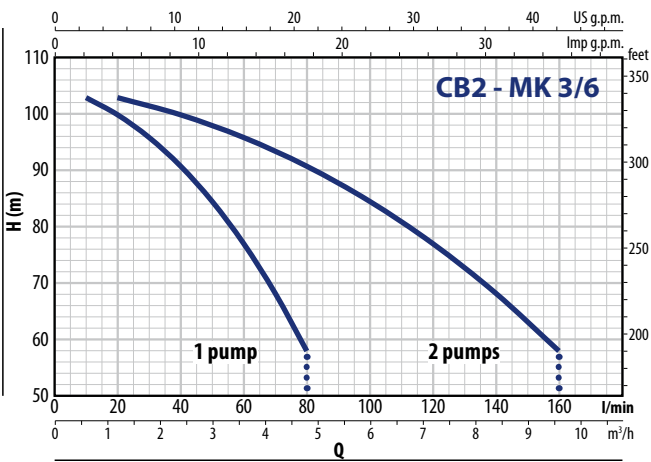
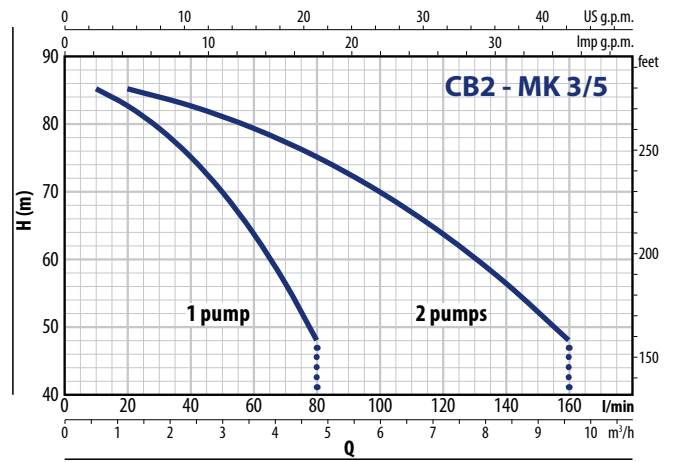
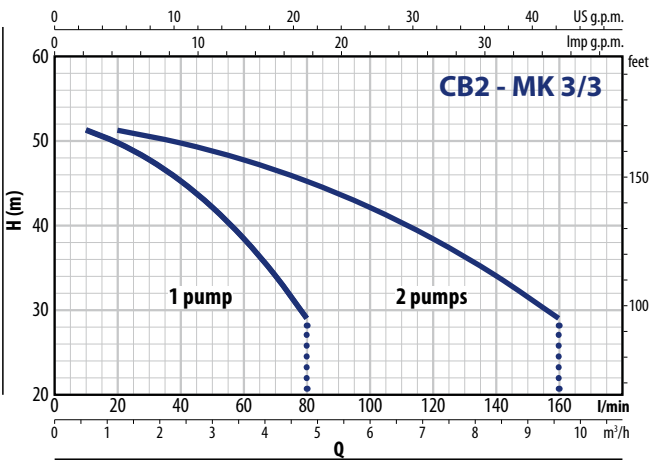

PERFORMANCE CURVES

50 Hz

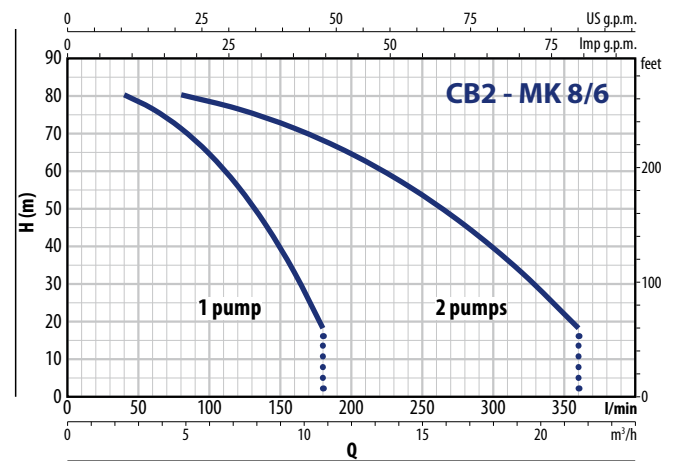
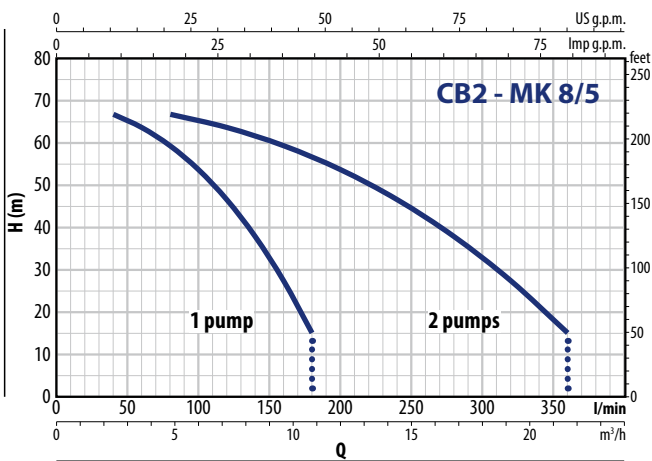

ABSORPTION

TYPE	VOLTAGE
Single-phase	230 V
CB2 - MKm 3/3	2 x 5.7 A
CB2 - MKm 3/5	2 x 7.8 A
CB2 - MKm 3/6	2 x 9.5 A
CB2 - MKm 5/4	2 x 5.7 A
CB2 - MKm 5/5	2 x 7.1 A
CB2 - MKm 5/7	2 x 9.3 A
CB2 - MKm 5/8	2 x 10.0 A
CB2 - MKm 8/4	2 x 7.8 A
CB2 - MKm 8/5	2 x 9.7 A
CB2 - MKm 8/6	2 x 11.1 A

TYPE	VOLTAGE
Three-phase	400 V
CB2 - MK 3/3	2 x 2.5 A
CB2 - MK 3/5	2 x 3.0 A
CB2 - MK 3/6	2 x 3.5 A
CB2 - MK 5/4	2 x 2.5 A
CB2 - MK 5/5	2 x 2.7 A
CB2 - MK 5/7	2 x 3.5 A
CB2 - MK 5/8	2 x 4.3 A
CB2 - MK 8/4	2 x 3.0 A
CB2 - MK 8/5	2 x 3.5 A
CB2 - MK 8/6	2 x 4.5 A

CB2 - MK

DIMENSIONS AND WEIGHT

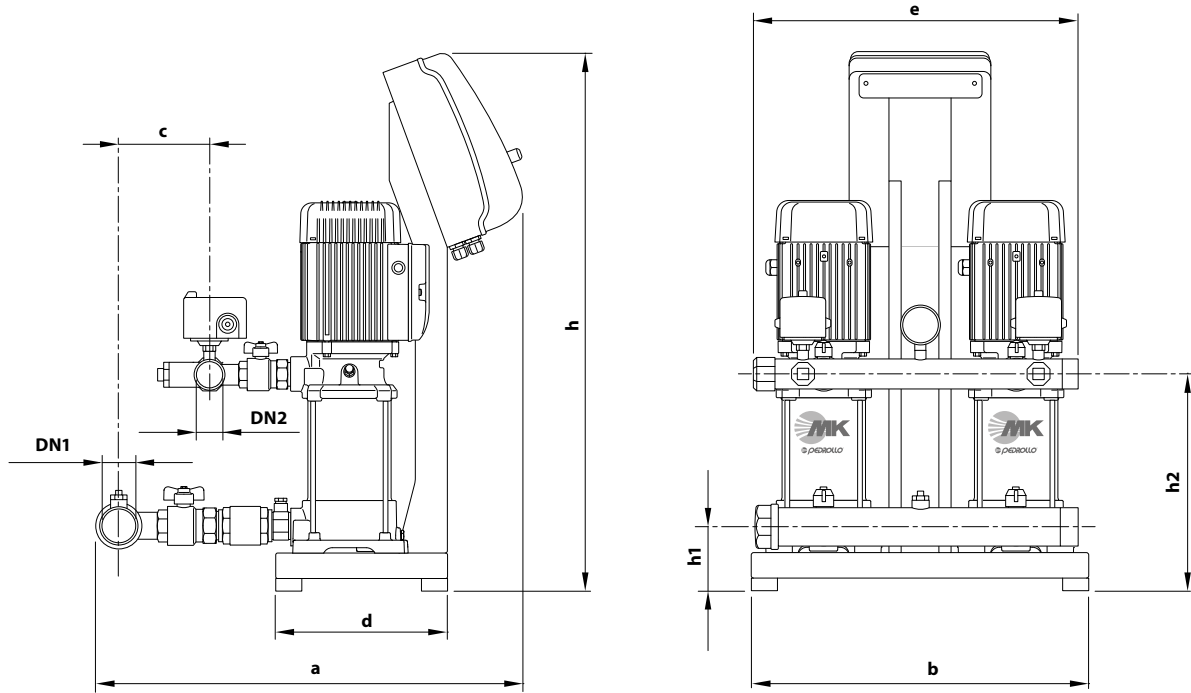

TYPE		PORTS		DIMENSIONS mm								kg	
Single-phase	Three-phase	DN1	DN2	a	b	c	d	e	h	h1	h2	1~	3~
CB2 - MKm 3/3	CB2 - MK 3/3	2"	1½"	673	530	135	270	510	854	102	234	75.0	73.0
CB2 - MKm 3/5	CB2 - MK 3/5										288	76.0	77.0
CB2 - MKm 3/6	CB2 - MK 3/6										315	80.0	81.0
CB2 - MKm 5/4	CB2 - MK 5/4										261	76.0	74.0
CB2 - MKm 5/5	CB2 - MK 5/5										288	76.0	77.0
CB2 - MKm 5/7	CB2 - MK 5/7										342	81.0	81.0
CB2 - MKm 5/8	CB2 - MK 5/8										369	82.0	82.0
CB2 - MKm 8/4	CB2 - MK 8/4	2½"	1½"	719	530	171	270	510	854	102	261	80.0	81.0
CB2 - MKm 8/5	CB2 - MK 8/5										288	81.0	81.0
CB2 - MKm 8/6	CB2 - MK 8/6										315	87.0	87.0

FIELD AND PERFORMANCE DATA

50 Hz

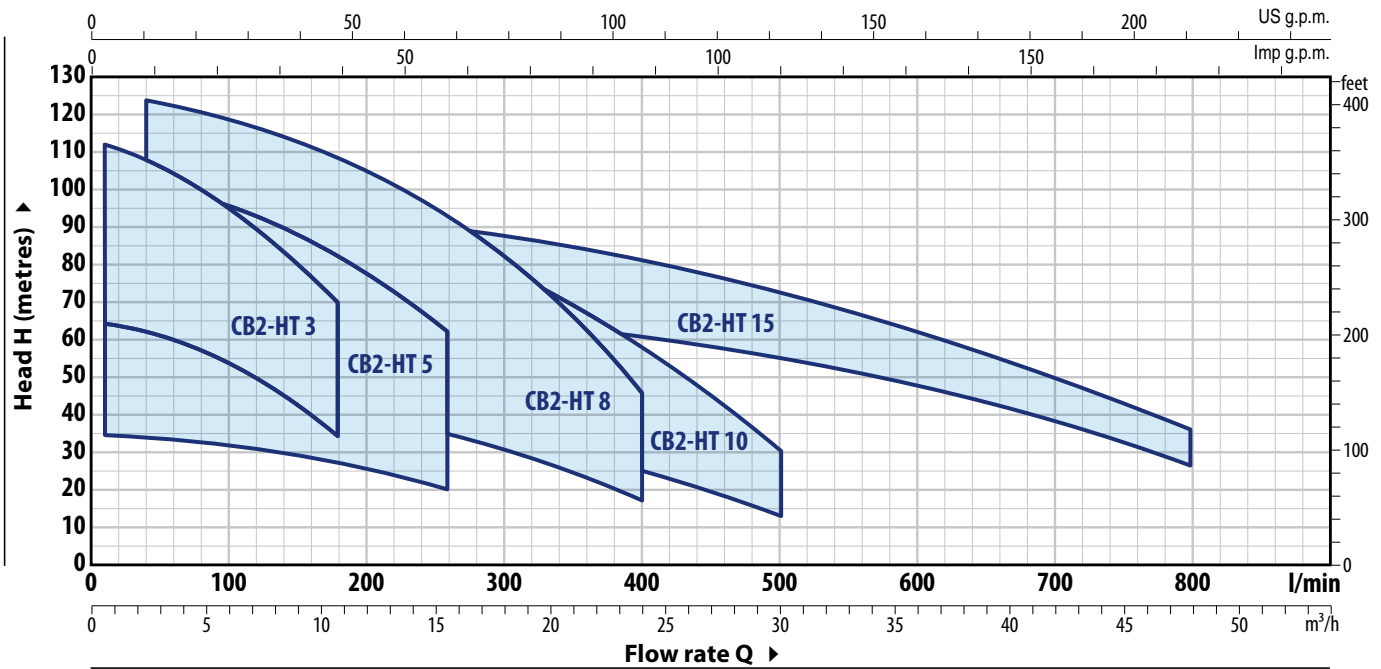

TYPE		POWER (P ₂)		Q	Flow rate																
Single-phase	Three-phase	kW	HP		m ³ /h	0	0.6	1.2	2.4	4.8	7.2	9.6	10.8	l/min	0	10	20	40	80	120	160
CB2 - HTm 3/4	CB2 - HT 3/4	2x0.75	2x1	H metres	65	65	63.5	62	57	50	40.5	35	65	65	63.5	62	57	50	40.5	35	
CB2 - HTm 3/5	CB2 - HT 3/5	2x1.1	2x1.5		81	80	79	77	71	62.5	51	44	81	80	79	77	71	62.5	51	44	
CB2 - HTm 3/6	CB2 - HT 3/6	2x1.5	2x2		97	96	95	93	86	75	61	52	97	96	95	93	86	75	61	52	
-	CB2 - HT 3/7	2x1.8	2x2.5		113	112	111	108	100	88	71	61	113	112	111	108	100	88	71	61	

TYPE		POWER (P ₂)		Q	Flow rate																				
Single-phase	Three-phase	kW	HP		m ³ /h	0	0.6	1.2	2.4	4.8	7.2	9.6	10.8	12	15.6	l/min	0	10	20	40	80	120	160	180	200
CB2 - HTm 5/2	CB2 - HT 5/2	2x0.75	2x1	H metres	35	35	32.7	32.3	32.5	31	25.5	27.5	26	20.5	35	35	32.7	32.3	32.5	31	25.5	27.5	26	20.5	
CB2 - HTm 5/3	CB2 - HT 5/3	2x1.1	2x1.5		51.5	51.5	51	50.5	49	46.5	43	41	39	31	51.5	51.5	51	50.5	49	46.5	43	41	39	31	
CB2 - HTm 5/4	CB2 - HT 5/4	2x1.5	2x2		68.5	68.5	68	67	65	62	57.5	55	52	41	68.5	68.5	68	67	65	62	57.5	55	52	41	
-	CB2 - HT 5/5	2x1.8	2x2.5		86	85	85	84	81	77	72	68.5	65	51.5	86	85	85	84	81	77	72	68.5	65	51.5	
-	CB2 - HT 5/6	2x2.2	2x3	103	103	102	101	98	93	86	82	78	62	103	103	102	101	98	93	86	82	78	62		

TYPE		POWER (P ₂)		Q	Flow rate																						
Single-phase	Three-phase	kW	HP		m ³ /h	0	2.4	4.8	7.2	9.6	12	14.4	16.8	19.2	21.6	24	l/min	0	40	80	120	160	200	240	280	320	360
CB2 - HTm 8/3	CB2 - HT 8/3	2x1.1	2x1.5	H metres	47	46.5	45.5	44	42	39.5	36.5	32.5	28	23.1	17	47	46.5	45.5	44	42	39.5	36.5	32.5	28	23.1	17	
CB2 - HTm 8/4	CB2 - HT 8/4	2x1.5	2x2		62.5	62	60.5	58.5	56	53	48.5	43.5	37.5	31	23	62.5	62	60.5	58.5	56	53	48.5	43.5	37.5	31	23	
-	CB2 - HT 8/5	2x1.8	2x2.5		78	77.5	76	73	70	66	61	54.5	47	38.5	28.5	78	77.5	76	73	70	66	61	54.5	47	38.5	28.5	
-	CB2 - HT 8/6	2x2.2	2x3		94	93	91	88	84	79	73	65.5	56.5	46	34.5	94	93	91	88	84	79	73	65.5	56.5	46	34.5	
※	CB2 - HT 8/7	2x3	2x4		109	108	106	103	98	92	85	76	66	54	40	109	108	106	103	98	92	85	76	66	54	40	

TYPE		POWER (P ₂)		Q	Flow rate																						
Single-phase	Three-phase	kW	HP		m ³ /h	0	3.6	6	7.2	9.6	14.4	18	20.4	24	26.4	30	l/min	0	60	100	120	160	240	300	340	400	440
※	CB2 - HTm 10/3	2x1.5	2x2	H metres	47	45.5	44	43.5	42	38	33.5	30.5	24.7	20.3	13	47	45.5	44	43.5	42	38	33.5	30.5	24.7	20.3	13	
※	CB2 - HTm 10/4	2x1.8	2x2.5		62	61	59	58	56	50.5	45	40.5	33	27	18	62	61	59	58	56	50.5	45	40.5	33	27	18	
※	-	2x2.2	2x3		77	75.5	74	73	70	63	56	50.5	41	34	21.5	77	75.5	74	73	70	63	56	50.5	41	34	21.5	
※	-	2x3	2x4		93	91	88	87	84	76	67.5	61	49.5	40.5	26	93	91	88	87	84	76	67.5	61	49.5	40.5	26	
※	CB2 - HT 10/7	2x3	2x4		108	106	103	102	98	88	79	71	57.5	47.5	30	108	106	103	102	98	88	79	71	57.5	47.5	30	

TYPE		POWER (P ₂)		Q	Flow rate														
Single-phase	Three-phase	kW	HP		m ³ /h	0	6	12	24	36	42	48	l/min	0	100	200	400	600	700
-	CB2 - HT 15/3	2x4	2x5.5	H metres	72	70	68.5	61	48	38.5	27	72	70	68.5	61	48	38.5	27	
-	CB2 - HT 15/4	2x5.5	2x7.5		96	94	91	81	64	51.5	36	96	94	91	81	64	51.5	36	

Q = Flow rate H = Total manometric head

Performance curves comply with EN ISO 9906 Grade 3B tolerance limits.

※ The data shown in the diagram and tables indicate performance with 2 pumps in operation

CB2 - HT

PERFORMANCE CURVES

50 Hz

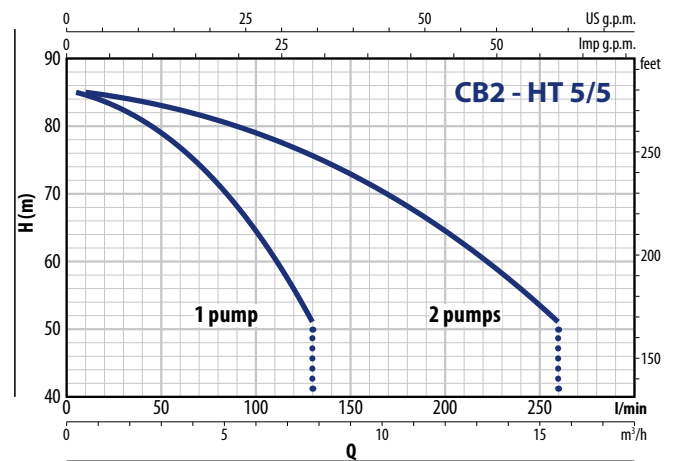
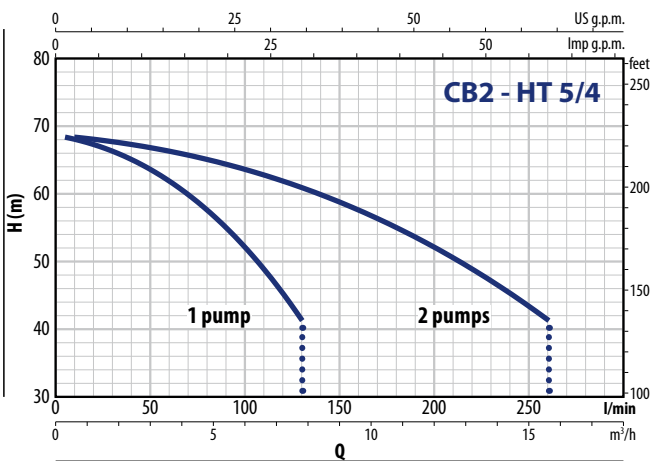
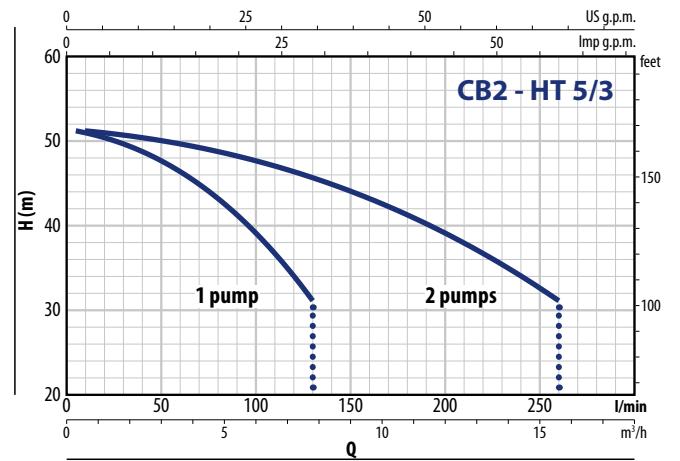
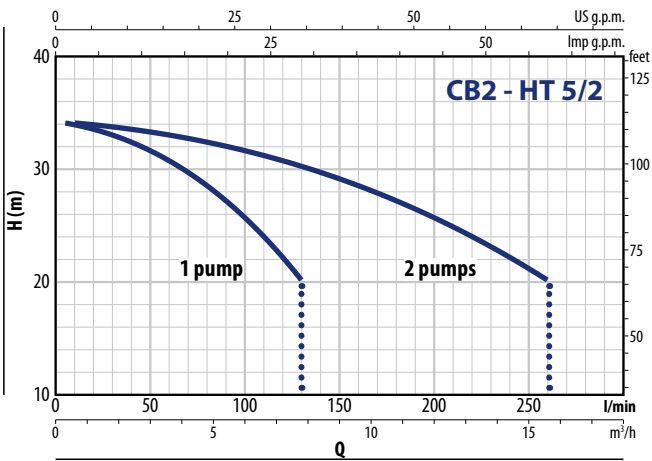
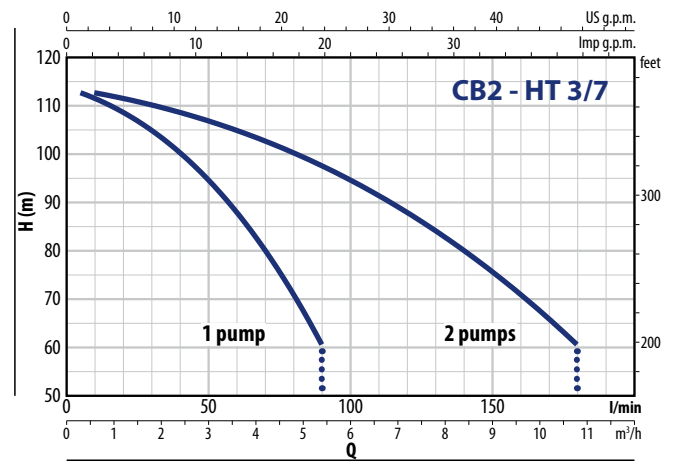
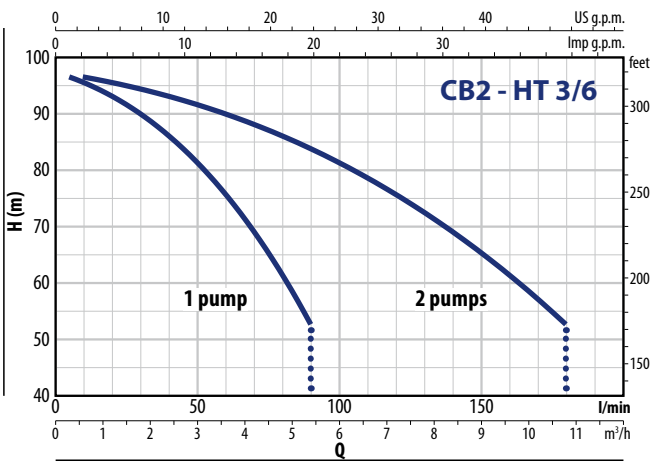
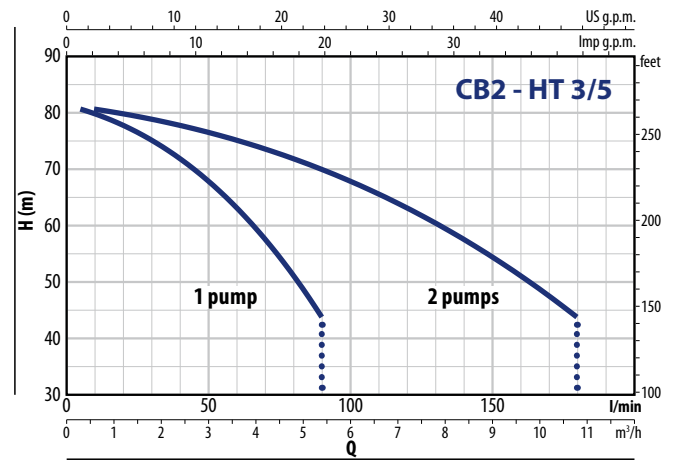
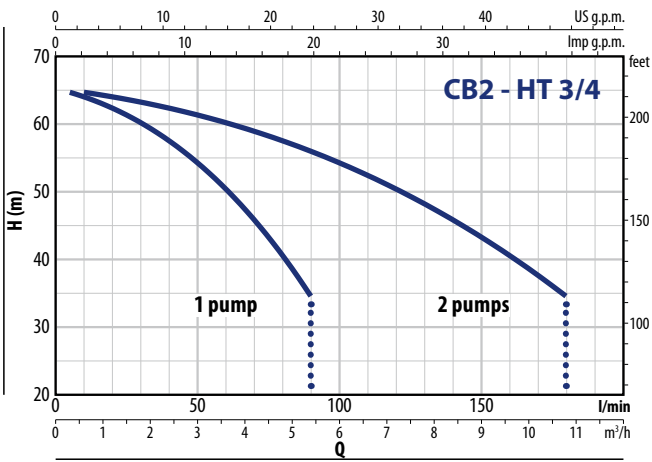

PERFORMANCE CURVES

50 Hz

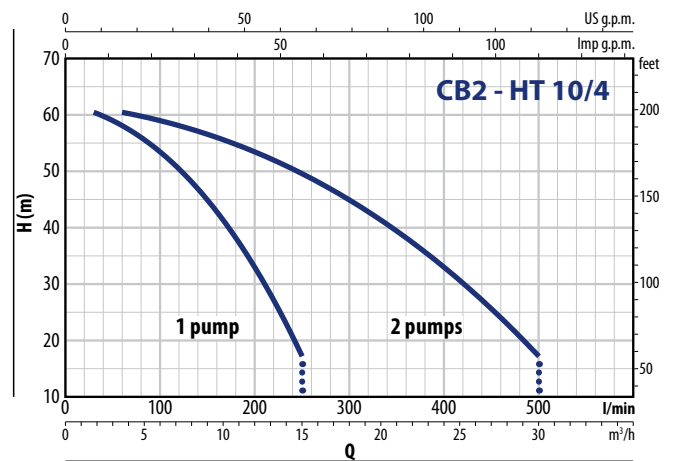
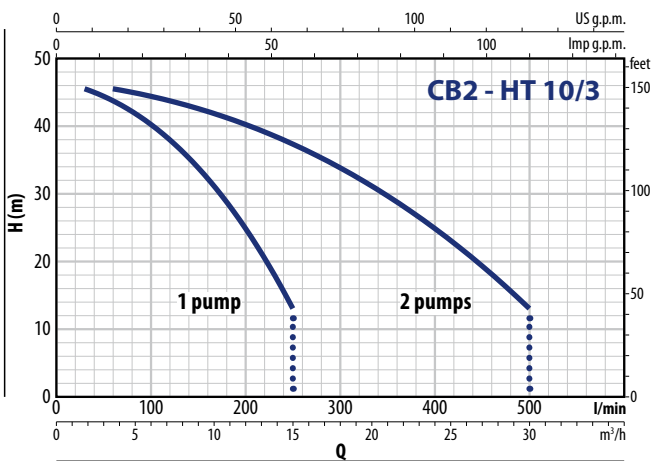
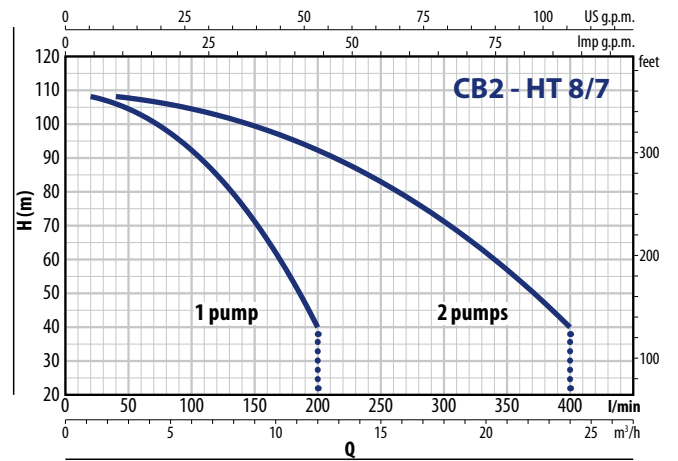
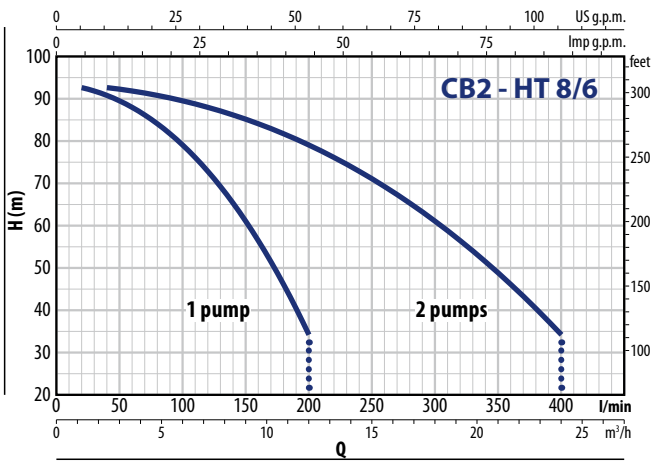
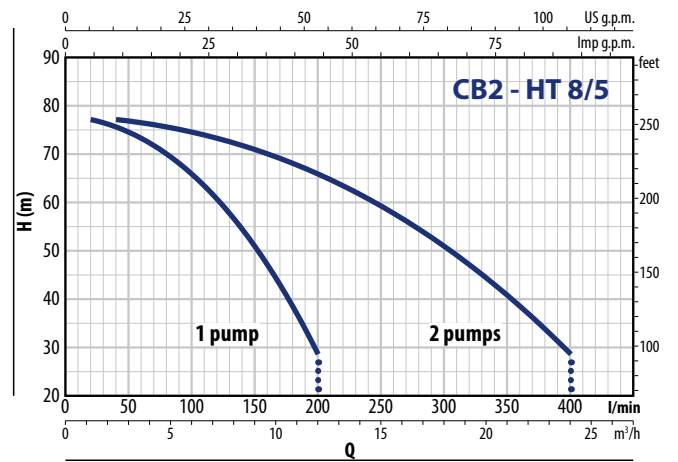
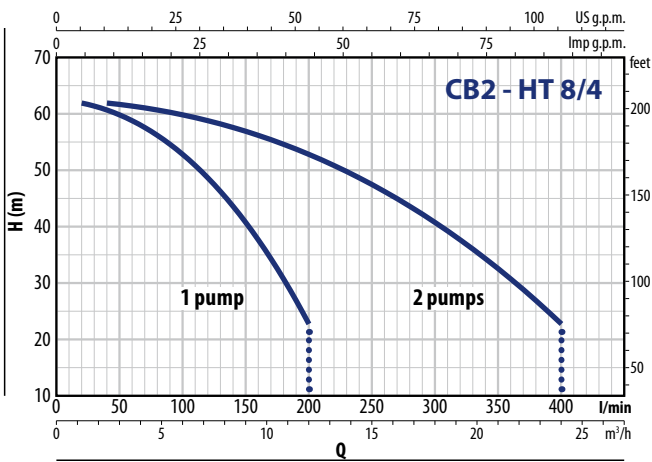
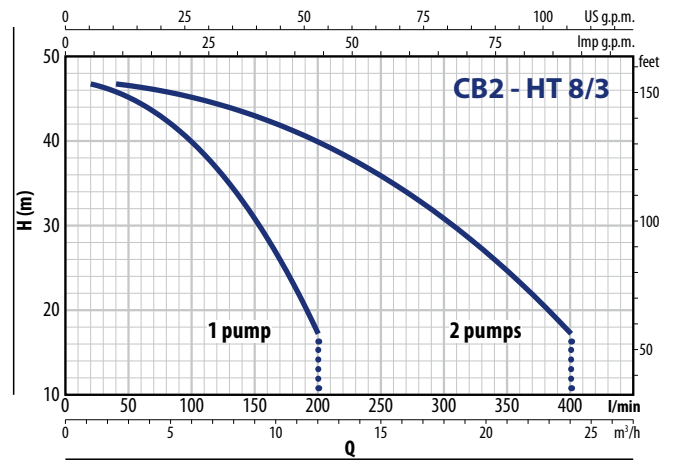
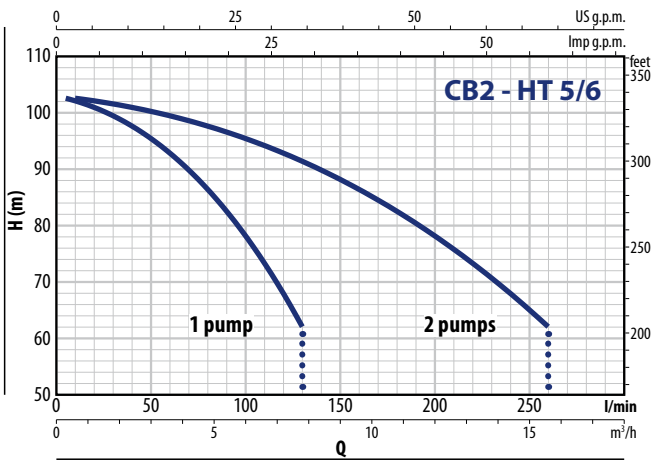

CB2 - HT

PERFORMANCE CURVES

50 Hz

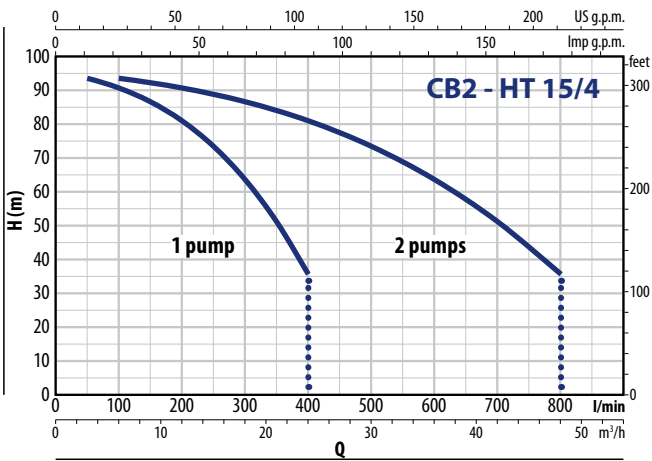
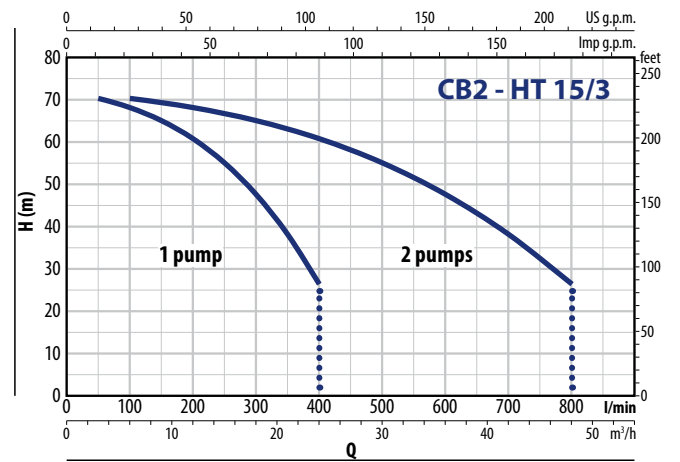
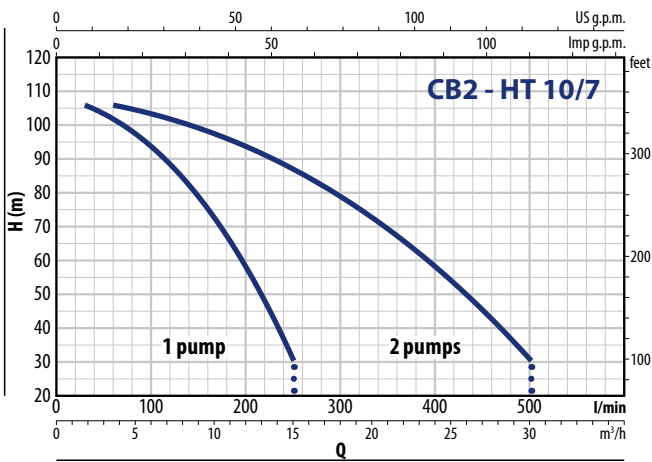
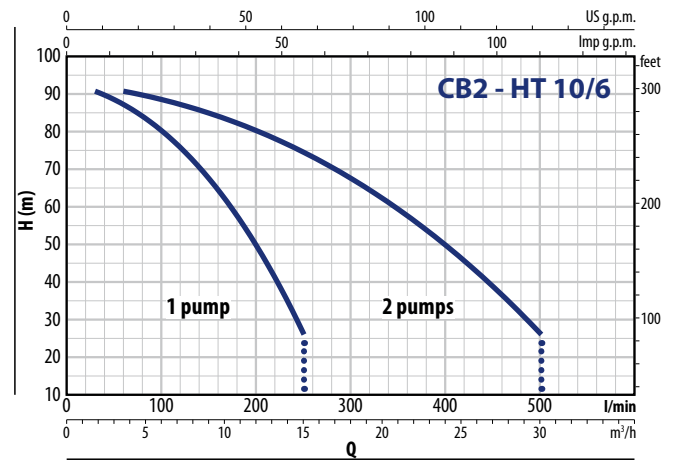
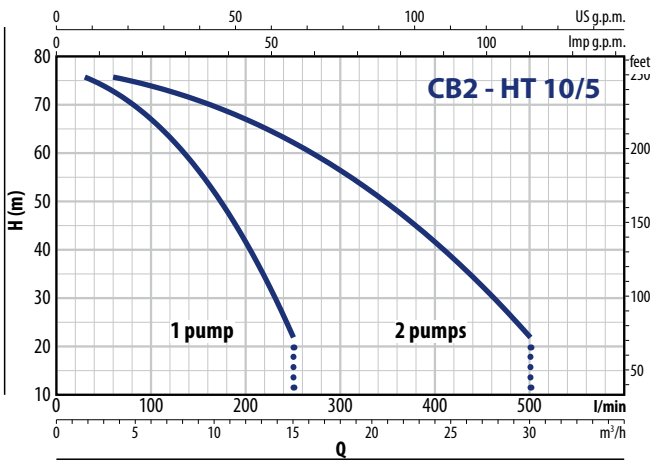

ABSORPTION

TYPE	VOLTAGE
Single-phase	230 V
CB2 - HTm 3/4	2 x 7.5 A
CB2 - HTm 3/5	2 x 9.0 A
CB2 - HTm 3/6	2 x 10.5 A
CB2 - HTm 5/2	2 x 6.1 A
CB2 - HTm 5/3	2 x 8.5 A
CB2 - HTm 5/4	2 x 10.3 A
CB2 - HTm 8/3	2 x 8.7 A
CB2 - HTm 8/4	2 x 10.5 A
CB2 - HTm 10/3	2 x 9.5 A
CB2 - HTm 10/4	2 x 11.0 A

TYPE	VOLTAGE
Three-phase	400 V
CB2 - HT 3/4	3.0 A
CB2 - HT 3/5	3.5 A
CB2 - HT 3/6	4.0 A
CB2 - HT 3/7	4.8 A

TYPE	VOLTAGE
Three-phase	400 V
CB2 - HT 5/2	2 x 2.8 A
CB2 - HT 5/3	2 x 3.2 A
CB2 - HT 5/4	2 x 3.8 A
CB2 - HT 5/5	2 x 4.8 A
CB2 - HT 5/6	2 x 5.2 A
CB2 - HT 8/3	2 x 3.3 A
CB2 - HT 8/4	2 x 4.0 A
CB2 - HT 8/5	2 x 4.8 A
CB2 - HT 8/6	2 x 5.4 A
CB2 - HT 8/7	2 x 7.0 A
CB2 - HT 10/3	2 x 3.4 A
CB2 - HT 10/4	2 x 4.5 A
CB2 - HT 10/5	2 x 5.2 A
CB2 - HT 10/6	2 x 6.5 A
CB2 - HT 10/7	2 x 7.2 A
CB2 - HT 15/3	2 x 8.8 A
CB2 - HT 15/4	2 x 11.2 A

DIMENSIONS AND WEIGHT

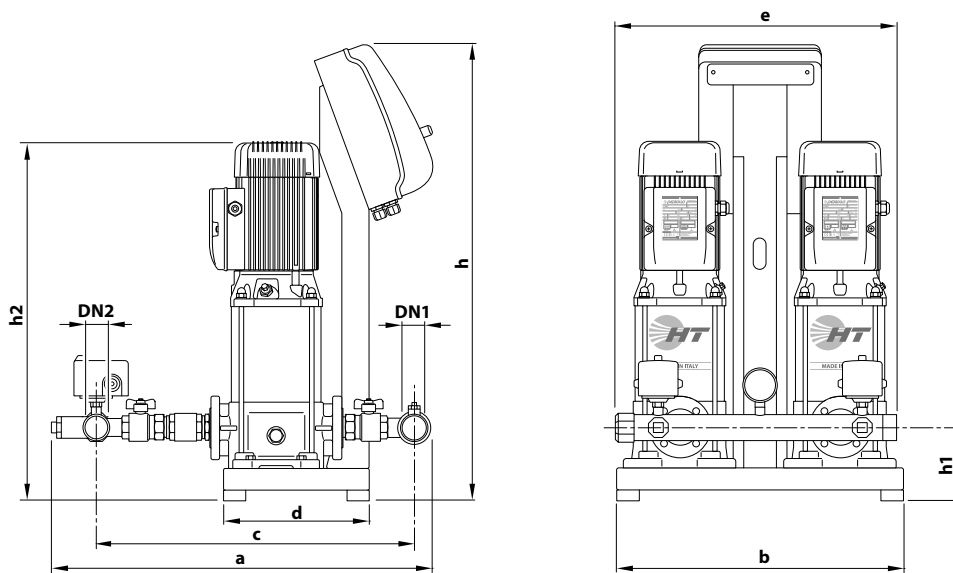

TYPE		PORTS		DIMENSIONS mm							kg		
Single-phase	Three-phase	DN1	DN2	a	b	c	d	e	h	h1	h2	1~	3~
CB2 - HTm 3/4	CB2 - HT 3/4	2"	2"	732	530	614	270	510	674	135	569	99	100
CB2 - HTm 3/5	CB2 - HT 3/5								595		100	100	
CB2 - HTm 3/6	CB2 - HT 3/6								621		102	102	
-	CB2 - HT 3/7								854		667	-	112
CB2 - HTm 5/2	CB2 - HT 5/2	2"	2"	779	530	661	270	510	674	135	517	99	100
CB2 - HTm 5/3	CB2 - HT 5/3								543		99	100	
CB2 - HTm 5/4	CB2 - HT 5/4								569		103	104	
-	CB2 - HT 5/5								854		615	-	109
-	CB2 - HT 5/6										641	-	111
CB2 - HTm 8/3	CB2 - HT 8/3	2½"	2½"	873	530	738	270	521	674	140	548	106	107
CB2 - HTm 8/4	CB2 - HT 8/4								574		110	111	
-	CB2 - HT 8/5								620		-	119	
-	CB2 - HT 8/6								646		-	120	
-	CB2 - HT 8/7								724		-	145	
CB2 - HTm 10/3	CB2 - HT 10/3	2½"	2½"	873	530	738	270	521	674	140	548	107	107
CB2 - HTm 10/4	CB2 - HT 10/4								594		111	111	
-	CB2 - HT 10/5								620		-	119	
-	CB2 - HT 15/3	3"	3"	993	700	850	370	728	674	150	693	-	175
-	CB2 - HT 15/4								737		-	187	

-  Clean water
-  Domestic use
-  Civil use



TS1-4CP 100



TS1-5CR 100



TS1-2CP

INSTALLATION AND USE

The **TISSEL-100** is a pumping unit designed for water supply and pressure boosting in residential settings, as well as for irrigation purposes. It seamlessly integrates with various pressurization systems, including existing ones, ensuring optimal comfort and significant energy savings.

PRODUCT DESCRIPTION

TISSEL-100 is a system comprising a pump and a water flow inverter with an integrated pressure sensor. It adjusts the motor speed based on water demand, maintaining constant system pressure.

TISSEL-100 is a plug-and-play product requiring no configuration. Users can adjust the system's working pressure and view operating parameters or alarms via the electrical panel. Experienced users can access advanced menus to customize factory settings for specific plant conditions. **TISSEL-100** includes a pump and a water flow inverter with an integrated pressure sensor, ensuring consistent pressure by adjusting motor speed based on water demand.

TISSEL-100 is a plug-and-play product that eliminates the need for configuration procedures. Users can easily adjust the system's operating pressure and monitor essential parameters or alarm messages via the electrical panel. For advanced users, **TISSEL-100** provides access to advanced menus for modifying factory parameters, allowing customization to meet specific facility conditions or system requirements.

TISSEL-100 is designed to protect the system from:

- ✘ dry running
- ✘ overcurrent
- ✘ overvoltage and undervoltage
- ✘ combustion chamber
- ✘ short circuit

TECHNICAL DATA

- Power supply: 1~ 230 V ± 10%
- Output voltage: 3~ 230 V
- Frequency: 50/60 Hz
- Maximum liquid temperature: +40 °C
- Maximum ambient temperature: +40 °C

COMPONENTS INCLUDED

- ✘ Three-phase pump
- ✘ Variable frequency drive with integrated non-return valve
- ✘ GSR quick-connect coupling
- ✘ 1.5 metres cable with Schuko plug

KEY FEATURES

- ✘ **Plug&Play** solution, ease of installation, and quick start-up
- ✘ Enhanced comfort ensured by consistent pressure operation
- ✘ Save energy with lower pump consumption.
- ✘ Protects the pump from faults by monitoring hydraulic and electrical operating parameters
- ✘ Reduced noise operation

PERFORMANCE RANGE

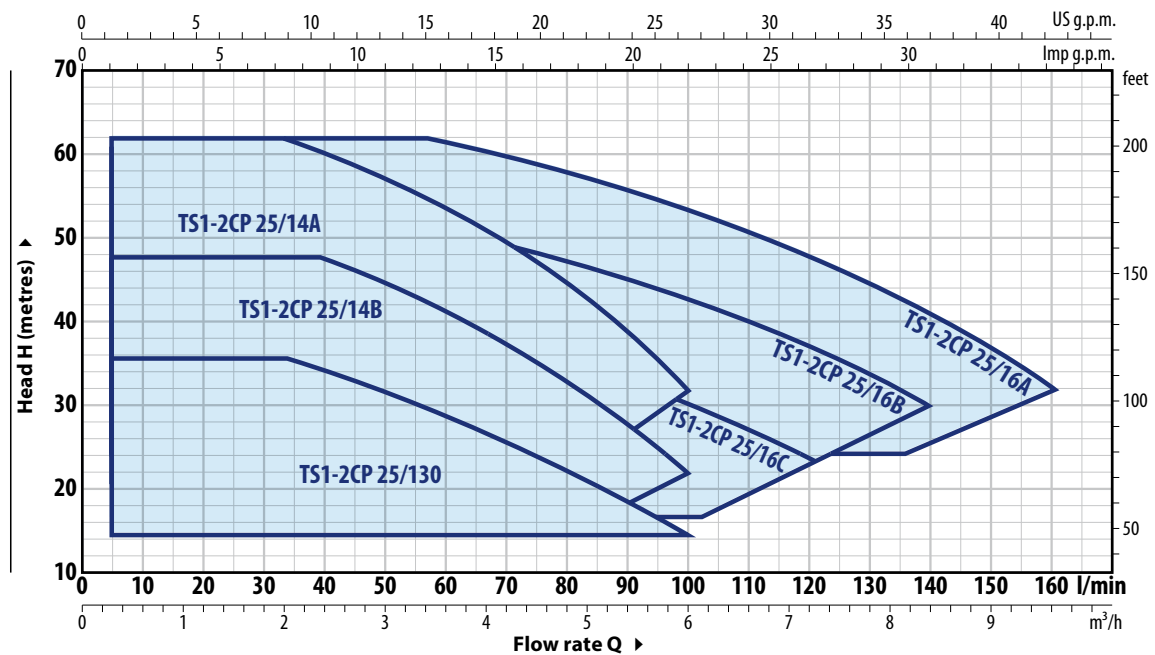
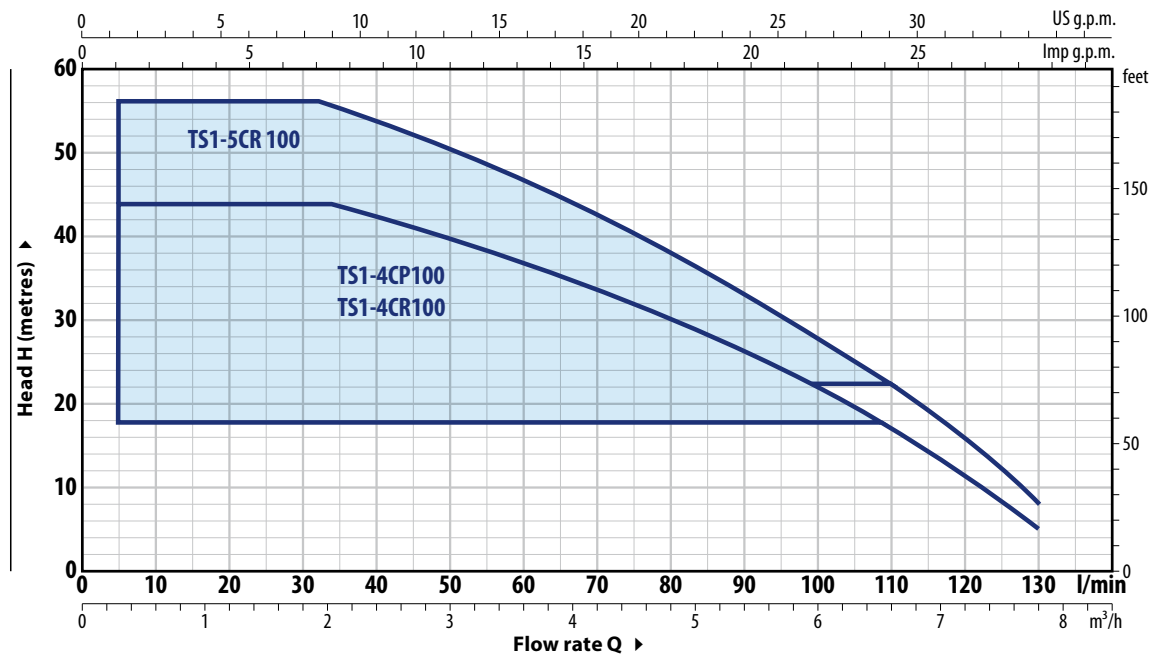

TYPE	POWER P ₂		ABSORPTION 230 V	PERFORMANCE		PERFORMANCE (ADJUSTABLE SET POINT)						
	kW	HP ▲		Q litres/min	H metres	Set Point Min		Set Point Calibration Std		Set Point Max		
Single-phase						bar	litres/min	bar	litres/min	bar	litres/min	
TS1-4CP 100	0.75	1	IE3	9.2 A	5 – 130	44 – 5	1.8	5 – 107	3.0	5 – 80	4.3	5 – 33
TS1-4CR 100	0.75	1		9.2 A	5 – 130	44 – 5	1.8	5 – 107	3.0	5 – 80	4.3	5 – 33
TS1-5CR 100	0.90	1.25		10.0 A	5 – 130	56 – 8	2.2	5 – 107	3.7	5 – 80	5.5	5 – 33
TS1-2CP 25/130	0.75	1	IE3	9.5 A	5 – 100	36 – 15	1.5	5 – 100	2.5	5 – 67	3.5	5 – 34
TS1-2CP 25/14B	1.1	1.5		10.5 A	5 – 100	48 – 22	1.9	5 – 92	3.6	5 – 70	4.7	5 – 35
TS1-2CP 25/14A	1.5	2		16.0 A	5 – 100	61 – 32	2.4	5 – 85	4.8	5 – 70	6.0	5 – 35
TS1-2CP 25/16C	1.1	1.5		11.5 A	5 – 120	41 – 24	1.7	5 – 100	3.2	5 – 85	4.0	5 – 52
TS1-2CP 25/16B	1.5	2		13.5 A	5 – 140	52 – 30	2.0	5 – 110	4.1	5 – 100	5.1	5 – 52
TS1-2CP 25/16A	2.2	3		21.5 A	5 – 160	62 – 32	2.4	5 – 135	4.8	5 (115)	6.1	5 – 52

Q = Flow rate H = Total manometric head

▲ Three-phase motor efficiency class (IEC 60034-30-1)

TISSEL-100

PERFORMANCE CURVES

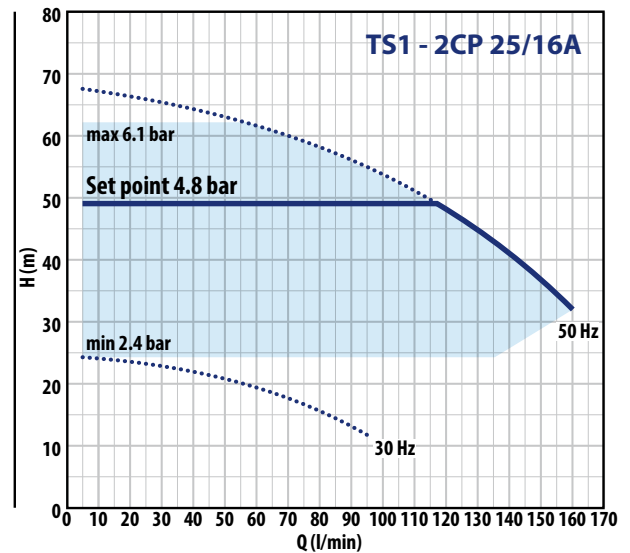
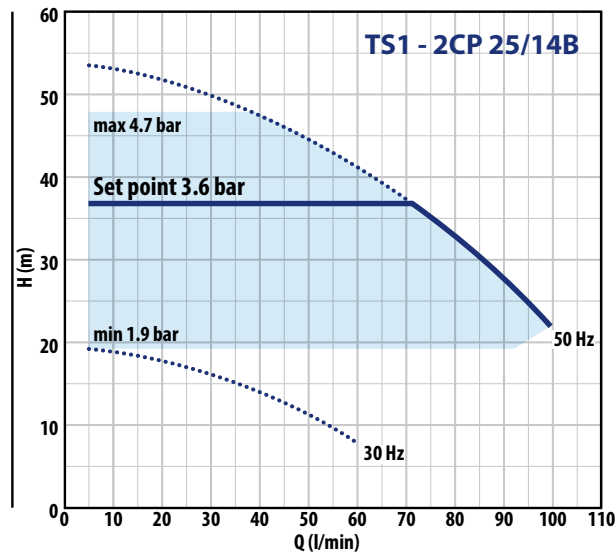
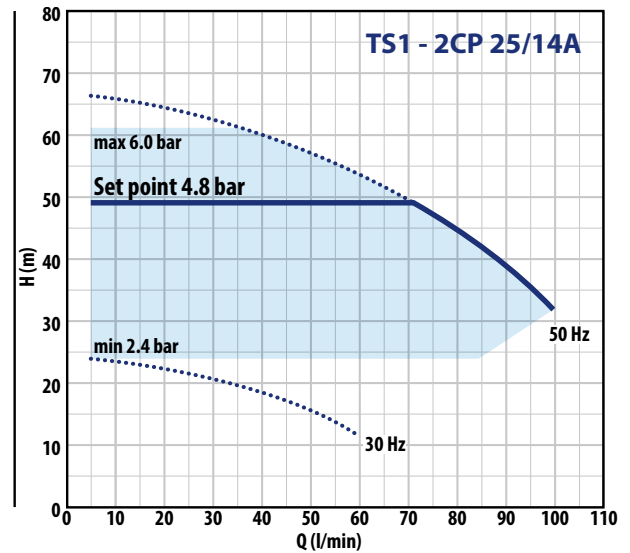
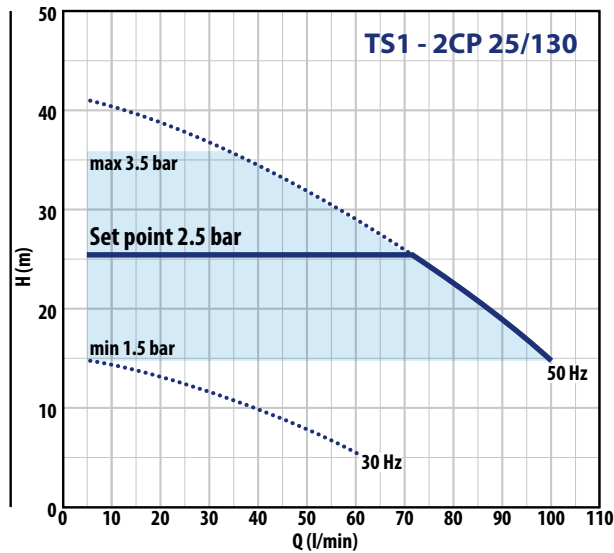
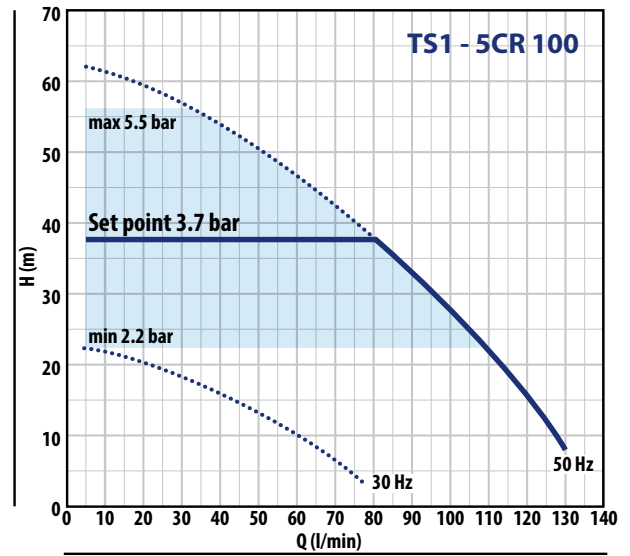
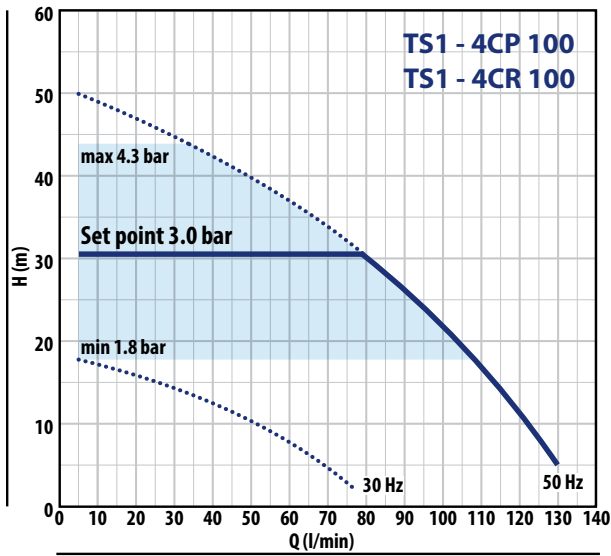

PERFORMANCE CURVES

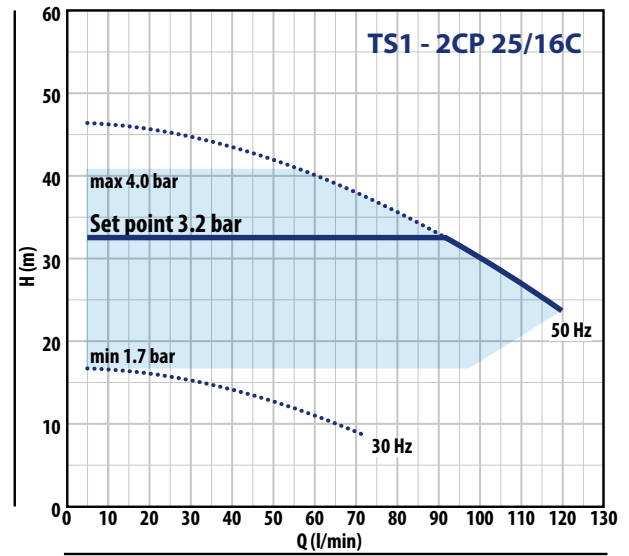
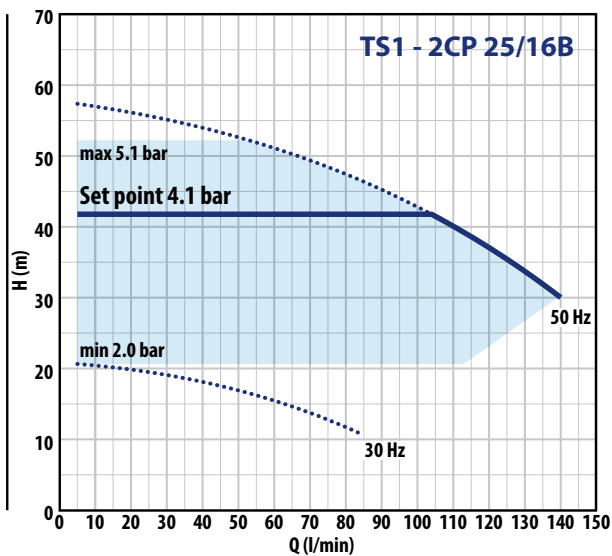

DIMENSIONS (mm)

TS1-4CP 100

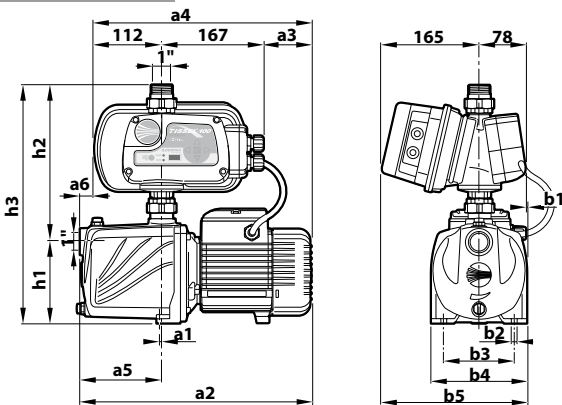

TS1-4CR 100X - TS1-5CR 100

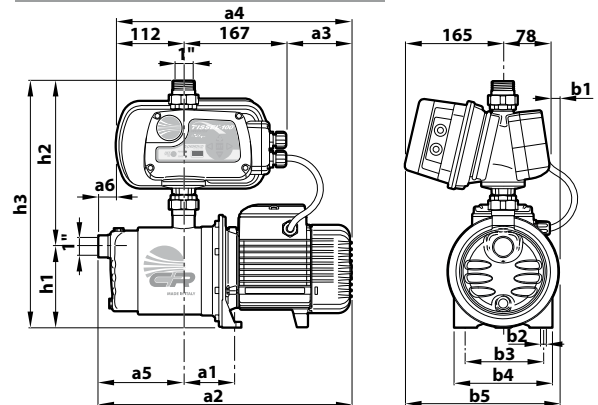

TS1-2CP 25/130

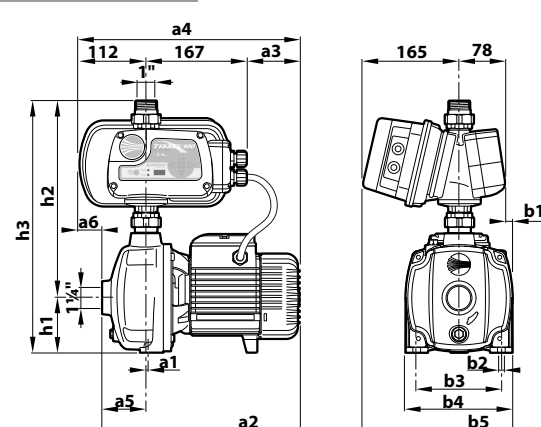

TS1-2CP 25/14 - TS1-2CP 25/16

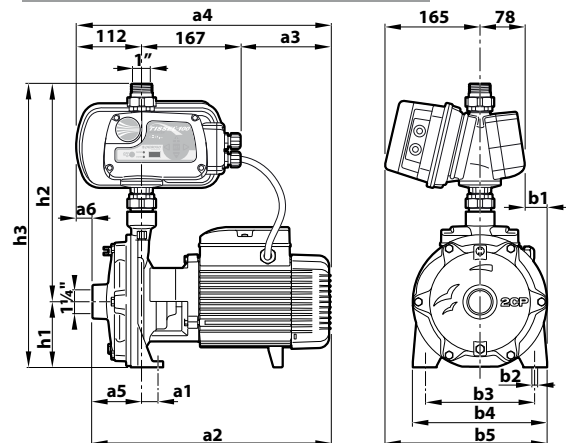

TYPE	a1	a2	a3	a4	b1	b2	b3	b4	b5	h1	h2	h3	kg
TS1-4CP 100	1.5	382	79	358	1	9	116	158	244	134	268	402	21.7
TS1-4CR 100	87	411	106	385	13	10	120	182	256	132	280	412	18.5
TS1-5CR 100	87	411	106	385	13	10	120	182	256	132	280	412	18.5
TS1-2CP 25/130	1	330	90	369	12	10	142	180	255	92	339	431	22.7
TS1-2CP 25/14B	17	404	155	434	22	10	162	200	265	93	360	453	28.6
TS1-2CP 25/14A	26	404	155	434	34	11	185	225	278	110	381	491	32.6
TS1-2CP 25/16C	17	404	155	434	22	10	162	200	265	93	360	453	28.4
TS1-2CP 25/16B	26	404	155	434	34	11	185	225	278	110	381	491	32.4
TS1-2CP 25/16A	26	424	175	454	34	11	185	225	278	110	381	491	35.2

-  Clean water
-  Domestic use
-  Civil use



INSTALLATION AND USE

VSP is a versatile pumping unit designed for various applications. It's ideal for residential and commercial use, providing water supply and pressure boosting.

VSP seamlessly integrates with any pressurization system, including existing ones, ensuring maximum comfort and enabling significant energy savings.

PRODUCT DESCRIPTION

VSP is a system comprising a pump and an integrated frequency converter. Equipped with a pressure sensor, it ensures a constant pressure as the system's water demand fluctuates.

This ready-to-use product eliminates the need for configuration procedures. Users can adjust the working pressure and view operating parameters and alarm messages via the electrical panel.

For advanced users, the system offers access to an advanced menu for modifying factory parameters through a guided procedure, allowing adaptation to specific plant conditions.

VSP is an intelligent pumping unit, equipped with:

- ✳ **display and keypad** allowing simple and intuitive configuration and reading of operating parameters;
- ✳ interface ports for additional **analogue** and **digital** input and output **signals**;
- ✳ **PFC technology** maintains hydraulic performance unaffected even when supply voltages vary within $\pm 20\%$ of the nominal value;
- ✳ **RS 485 communication** for connection to a second device in parallel.

Integrated protection against:

- ✳ dry running
- ✳ overcurrent
- ✳ overvoltage and undervoltage
- ✳ combustion chamber
- ✳ short circuit
- ✳ lack of phases in the connections (for three-phase version)

TECHNICAL DATA

- Power supply:
 - 1~ 230V $\pm 10\%$ or 3~ 400V $\pm 10\%$
 - Frequency: 50/60 Hz
- Please refer to the technical data of the specific electro-pumps for liquid temperature, ambient temperature, and protection degree.

KEY FEATURES

- ✳ Easy installation, configuration, and adjustment.
- ✳ Greater comfort, thanks to optimized performance and low noise levels.
- ✳ Energy saving reduces startup and operating currents, ensuring.
- ✳ Automatic compensation for fluctuations in the supply voltage.
- ✳ Communication with another device to enhance system capabilities.
- ✳ Intelligent management of control and intervention in case of anomalies.

ELECTRICAL PANEL

It enables access to configuration menus, navigation through settings, adjustment of operating parameters, and activation or deactivation of the pumping unit.

1. Scroll arrow keys (▼) (▲)
2. ESC menu exit key (ESC)
3. ON/OFF button (⏻)
4. Confirmation button OK (OK)
5. 4-backlit display to indicate the operating status of the VSP

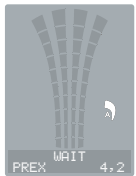

WHITE display
EXPECTATION



Display VERDE
START



RED display
ERROR



YELLOW display
(MENU OF
PROGRAMMING

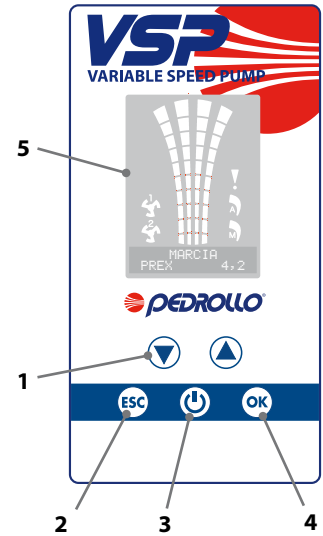

DISPLAY SYMBOLS

6. ALARM warning light !
7. AUTOMATIC operation indicator light (A)
8. MANUAL operation indicator light (M)
9. Indicator light for running pump no. 1 (P1)
10. Indicator light for running pump no. 2 (P2) (if present)
11. WI-FI active indicator light (Wi-Fi symbol) (if present)
12. Alphanumeric display with 2 lines for visualization of: voltage, frequency, current, power factor (cosφ), pressure, level, system operating status, system anomalies.
13. VSP operating status LED lights

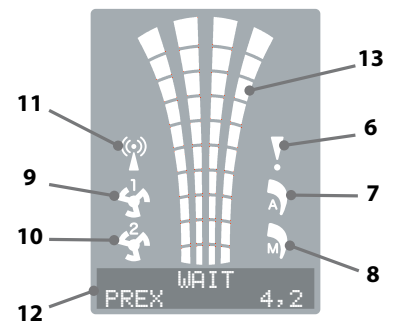

TYPICAL INSTALLATION

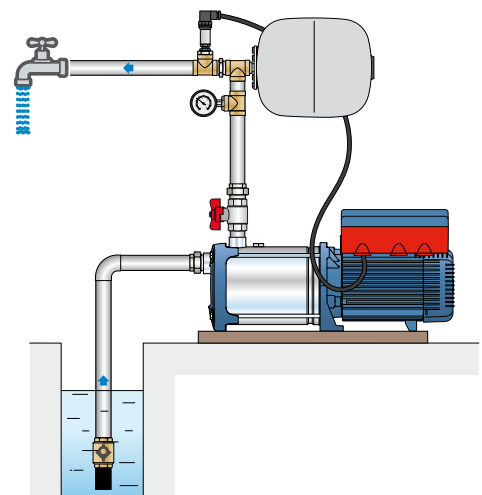
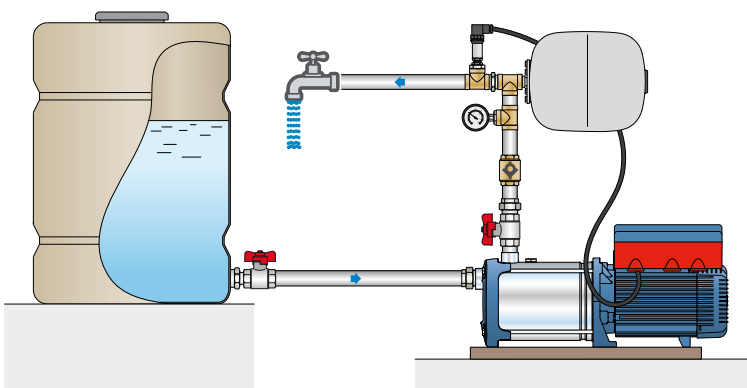

VSP – FCR

PERFORMANCE RANGE

50 Hz

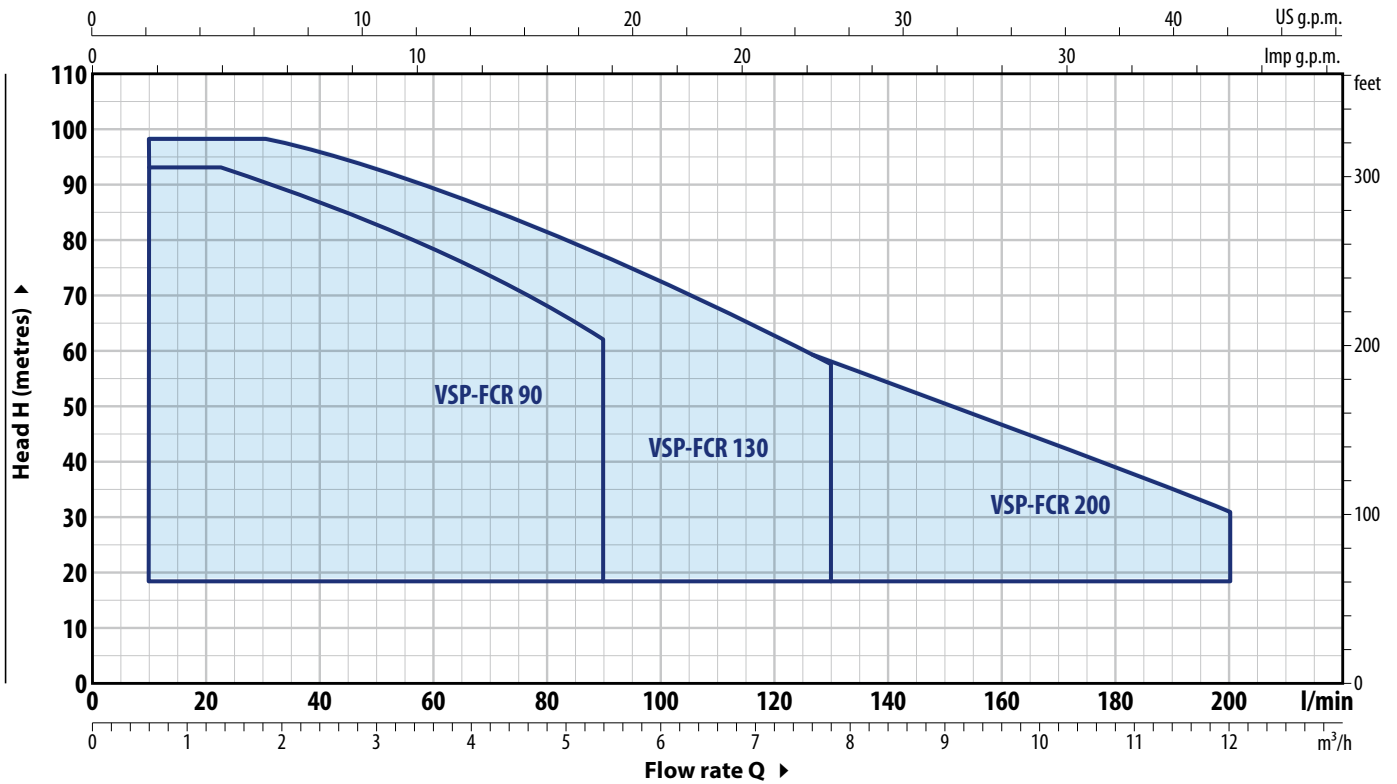

TECHNICAL DATA

TYPE	POWER		ABSORPTION 230 V	PERFORMANCE		PERFORMANCE (ADJUSTABLE SET POINT)					
	P ₂ kW	HP		Q litres/min	H metres	Set Point Min		Set Point Calibration Std		Set Point Max	
Single-phase						bar	l/min	bar	l/min	bar	l/min
VSPm - FCR 75/90	1.5	2	9.8 A	5 – 90	71.5 – 43.5	1.9	5 – 60	4.0	5 – 86	7.0	5 – 16
VSPm - FCR 80/130	1.5	2	9.8 A	5 – 130	74.5 – 30	2.0	5 – 107	4.0	5 – 107	7.3	5 – 22
VSPm - FCR 70/200	1.5	2	9.8 A	5 – 200	65.5 – 21	1.8	5 – 180	4.0	5 – 115	6.4	5 – 36

TYPE	POWER		ABSORPTION 400 V	PERFORMANCE		PERFORMANCE (ADJUSTABLE SET POINT)					
	P ₂ kW	HP		Q litres/min	H metres	Set Point Min		Set Point Calibration Std		Set Point Max	
Three-phase						bar	l/min	bar	l/min	bar	l/min
VSP - FCR 75/90	1.5	2	3.6 A	5 – 90	71.5 – 43.5	1.9	5 – 60	4.0	5 – 86	7.0	5 – 16
VSP - FCR 100/90	2.2	3	4.9 A	5 – 90	94 – 62.5	2.5	5 – 58	4.0	5 – 71	9.2	5 – 20
VSP - FCR 80/130	1.5	2	3.6 A	5 – 130	74.5 – 30	2.0	5 – 107	4.0	5 – 107	7.3	5 – 22
VSP - FCR 105/130	2.2	3	4.9 A	5 – 130	98 – 57.5	2.7	5 – 90	4.0	5 – 107	9.6	5 – 30
VSP - FCR 70/200	1.5	2	3.6 A	5 – 200	65.5 – 21	1.8	5 – 180	4.0	5 – 115	6.4	5 – 36
VSP - FCR 95/200	2.2	3	4.9 A	5 – 200	87.5 – 42	2.4	5 – 178	4.0	5 – 175	8.6	5 – 32

PERFORMANCE CURVES

50 Hz

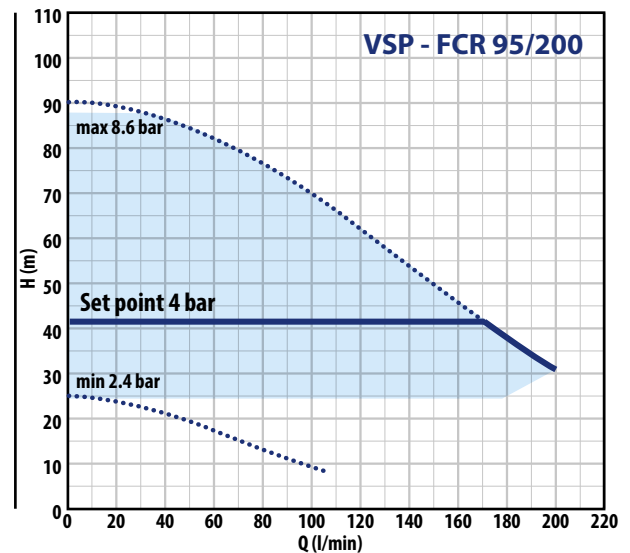
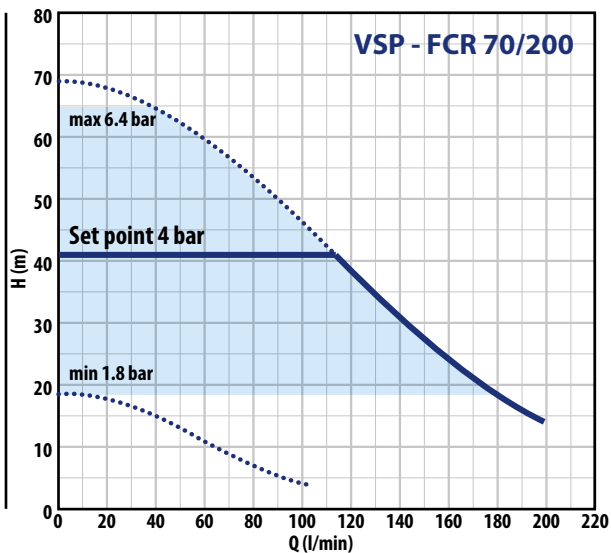
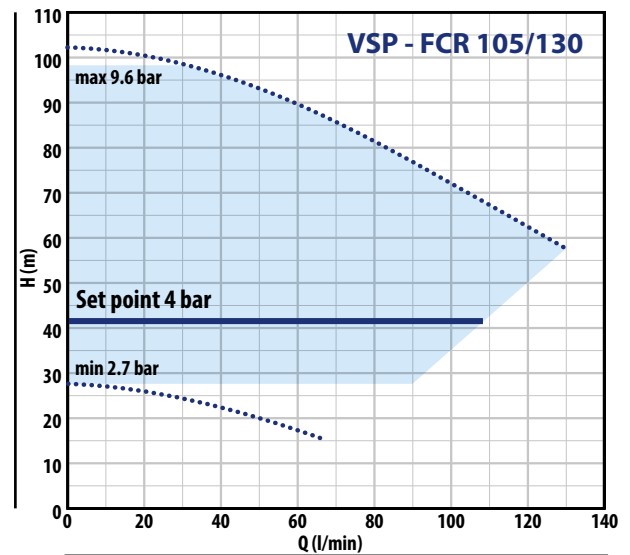
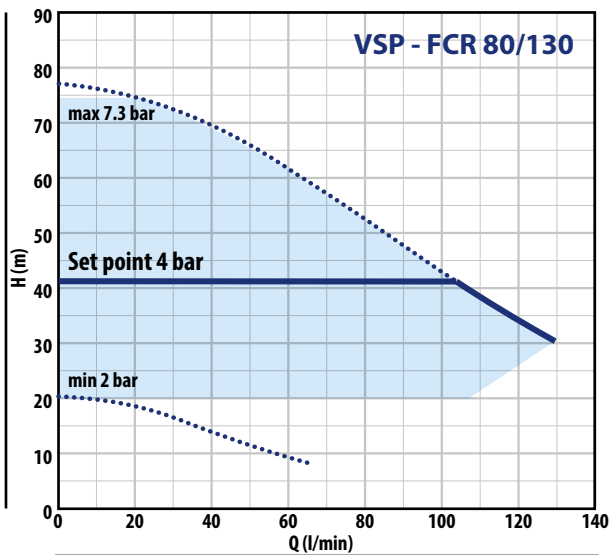
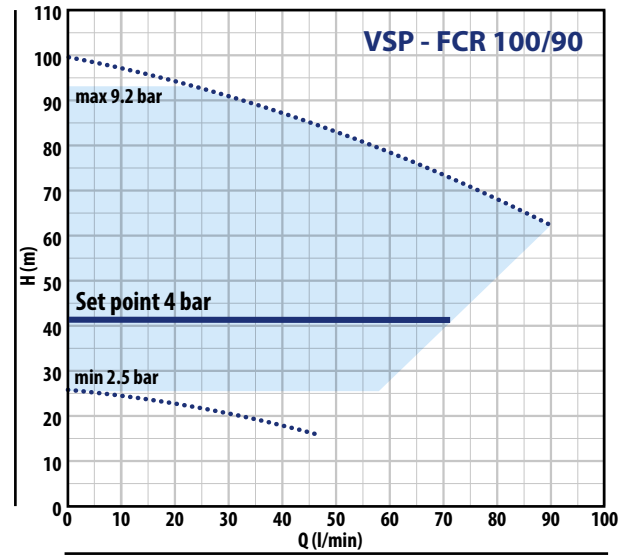
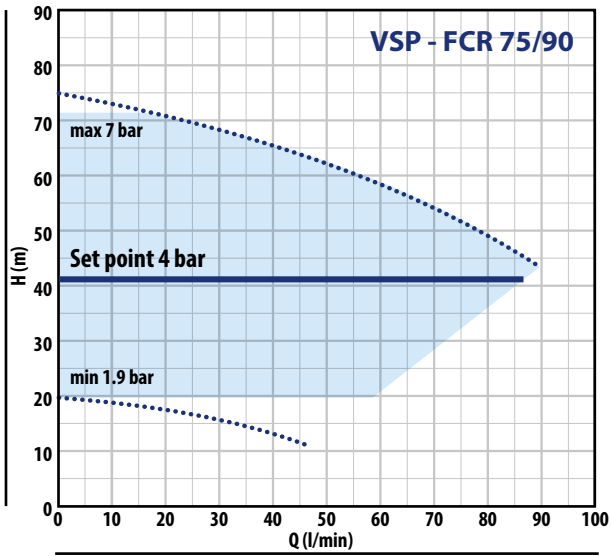

VSP – FCR

DIMENSIONS AND WEIGHT

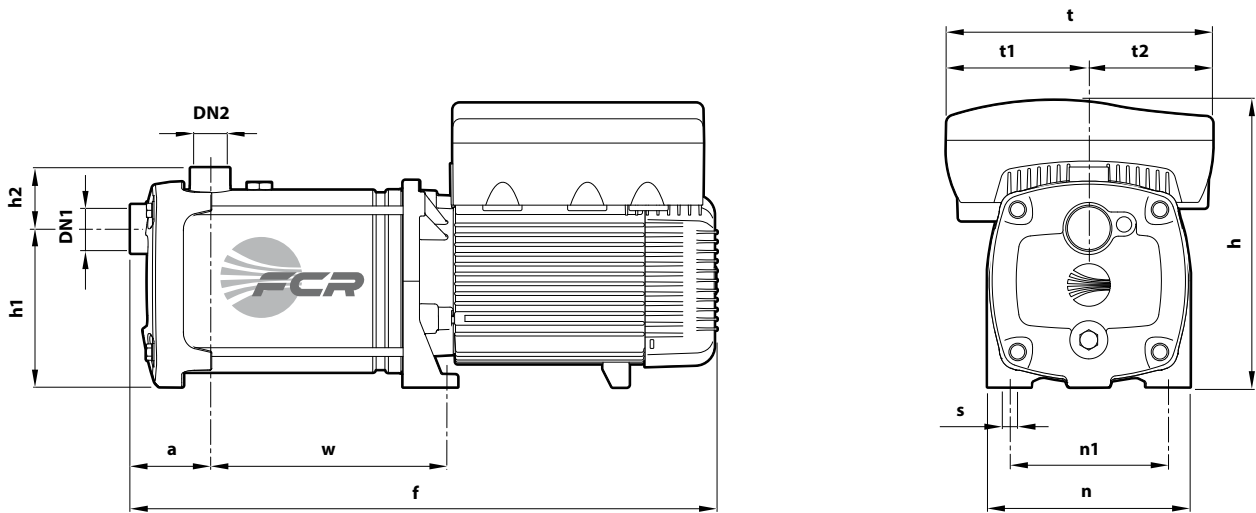

TYPE		PORTS		DIMENSIONS mm											kg		
Single-phase	Three-phase	DN1	DN2	f	a	w	h	h1	h2	t	t1	t2	n	n1	s	1~	3~
VSPm - FCR 75/90	VSP - FCR 75/90	1 1/4"	1"	445	75	139	260	145	59	242	129	113	185	145	11	21.7	21.7
-	VSP - FCR 100/90			471		165										-	21.9
VSPm - FCR 80/130	VSP - FCR 80/130			445		139										21.9	21.9
-	VSP - FCR 105/130			471		165										-	21.9
VSPm - FCR 70/200	VSP - FCR 70/200			445		139										24.1	23.9
-	VSP - FCR 95/200			471		165										-	24.0

PERFORMANCE RANGE

50 Hz

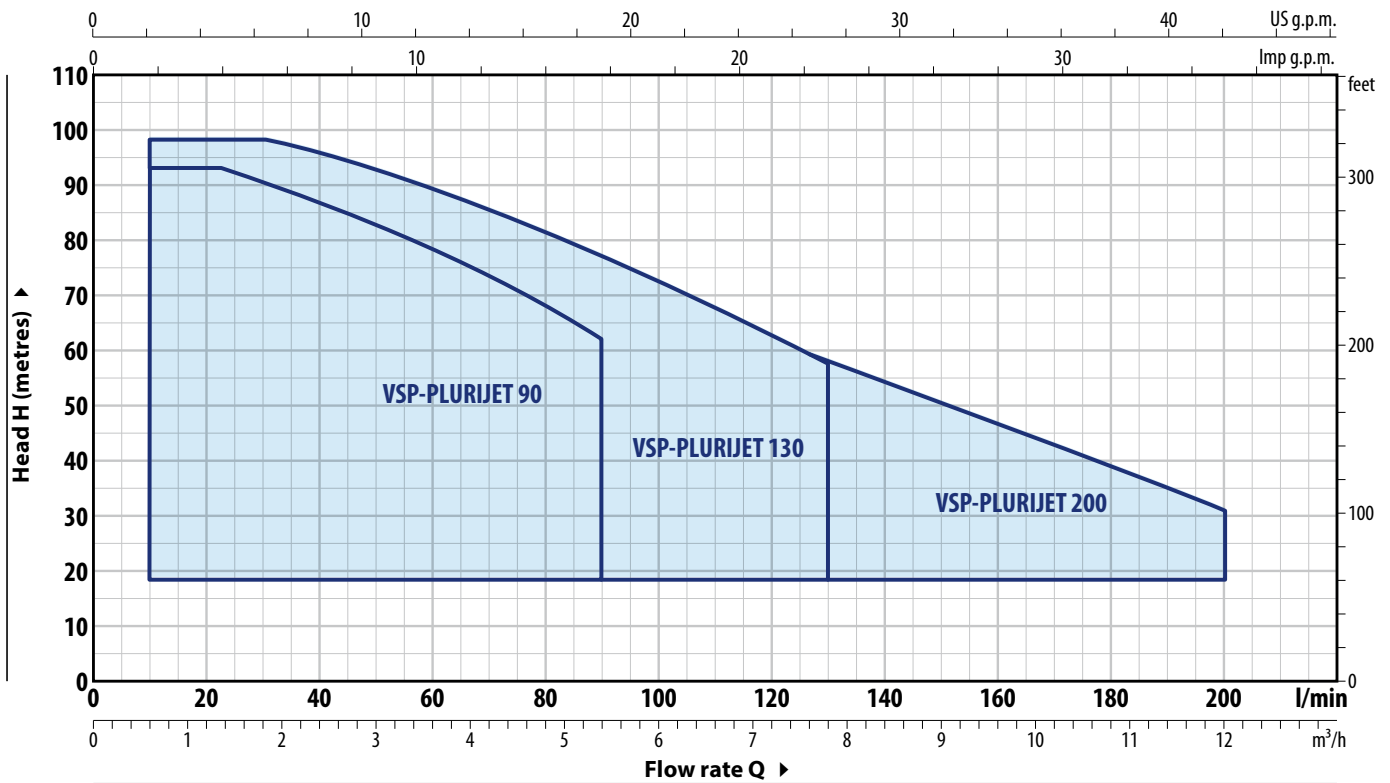

TECHNICAL DATA

TYPE	POWER		ABSORPTION	PERFORMANCE		PERFORMANCE (ADJUSTABLE SET POINT)					
	P ₂			Q	H	Set Point Min		Set Point Calibration Std		Set Point Max	
Single-phase	kW	HP	230 V			litres/min	metres	bar	l/min	bar	l/min
VSPm - PLURIJET 75/90	1.5	2	9.8 A	5 – 90	71.5 – 43.5	1.9	5 – 60	4.0	5 – 86	7.0	5 – 16
VSPm - PLURIJET 80/130	1.5	2	9.8 A	5 – 130	74.5 – 30	2.0	5 – 107	4.0	5 – 107	7.3	5 – 22
VSPm - PLURIJET 70/200	1.5	2	9.8 A	5 – 200	65.5 – 21	1.8	5 – 180	4.0	5 – 115	6.4	5 – 36

TYPE	POWER		ABSORPTION	PERFORMANCE		PERFORMANCE (ADJUSTABLE SET POINT)					
	P ₂			Q	H	Set Point Min		Set Point Calibration Std		Set Point Max	
Three-phase	kW	HP	400 V			litres/min	metres	bar	l/min	bar	l/min
VSP - PLURIJET 75/90	1.5	2	3.6 A	5 – 90	71.5 – 43.5	1.9	5 – 60	4.0	5 – 86	7.0	5 – 16
VSP - PLURIJET 100/90	2.2	3	4.9 A	5 – 90	94 – 62.5	2.5	5 – 58	4.0	5 – 71	9.2	5 – 20
VSP - PLURIJET 80/130	1.5	2	3.6 A	5 – 130	74.5 – 30	2.0	5 – 107	4.0	5 – 107	7.3	5 – 22
VSP - PLURIJET 105/130	2.2	3	4.9 A	5 – 130	98 – 57.5	2.7	5 – 90	4.0	5 – 107	9.6	5 – 30
VSP - PLURIJET 70/200	1.5	2	3.6 A	5 – 200	65.5 – 21	1.8	5 – 180	4.0	5 – 115	6.4	5 – 36
VSP - PLURIJET 95/200	2.2	3	4.9 A	5 – 200	87.5 – 42	2.4	5 – 178	4.0	5 – 175	8.6	5 – 32

VSP - PLURIJET

PERFORMANCE CURVES

50 Hz

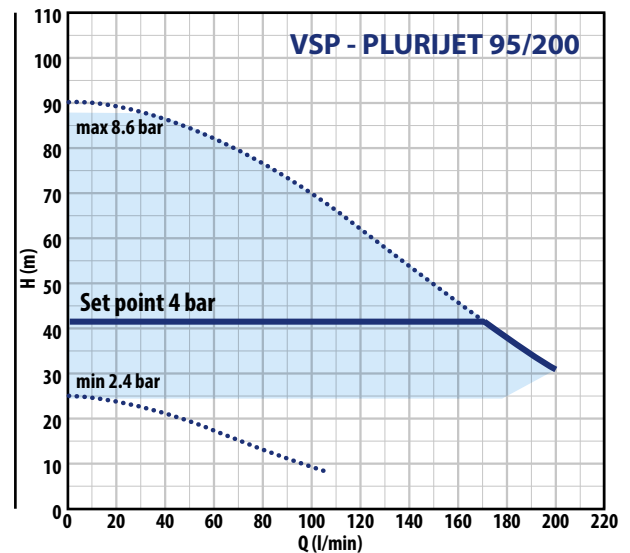
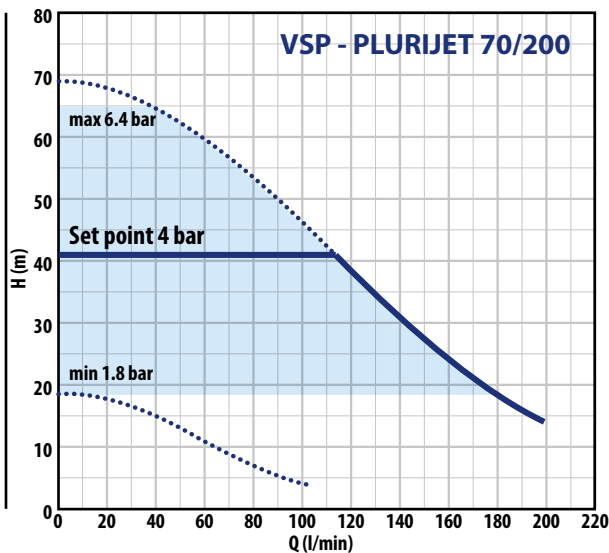
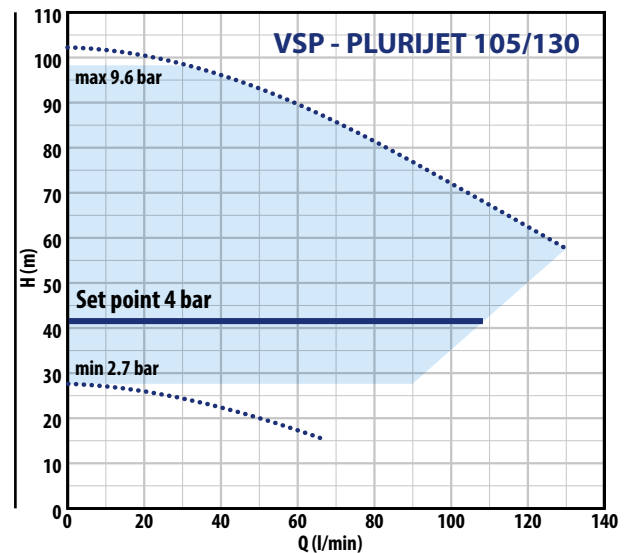
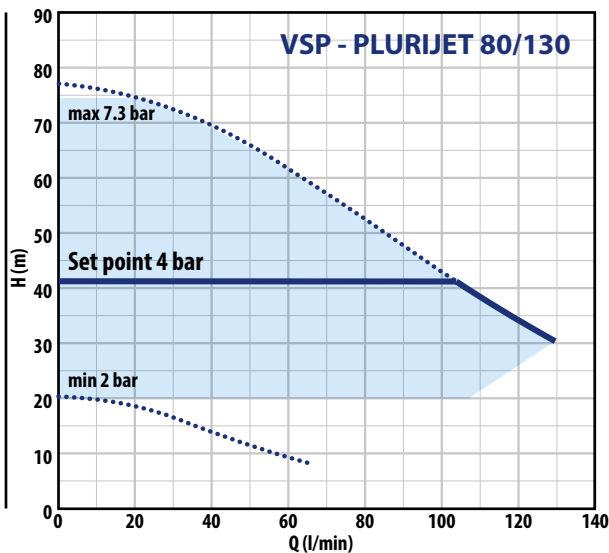
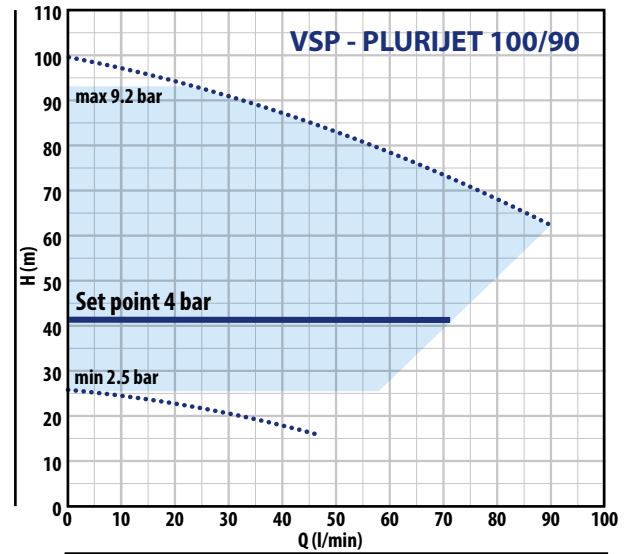
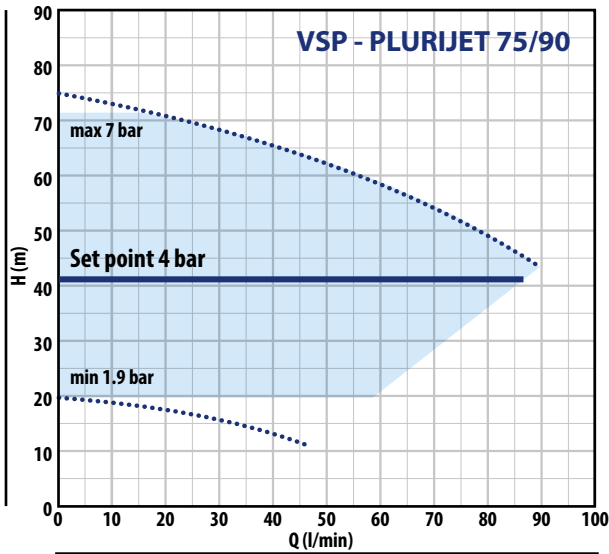

DIMENSIONS AND WEIGHT

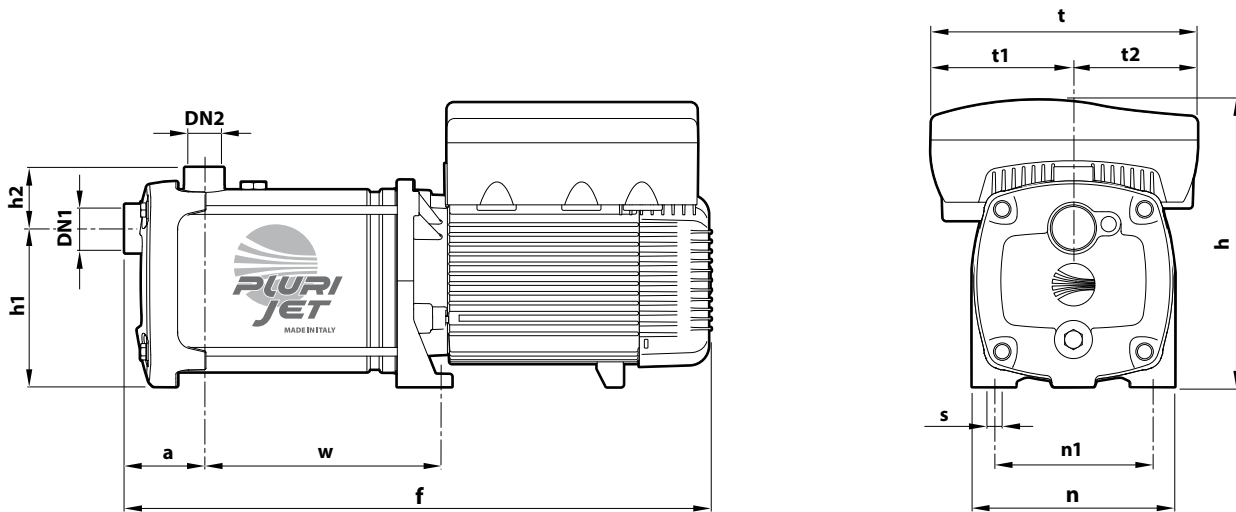

Single-phase	TYPE		PORTS		DIMENSIONS mm											kg				
	Three-phase		DN1	DN2	f	a	w	h	h1	h2	t	t1	t2	n	n1	s	1~	3~		
VSPm - PLURIJET 75/90	VSP - PLURIJET 75/90		1 1/4"	1"	497		191										21.7	21.7		
-	VSP - PLURIJET 100/90				523		217											-	23.9	
VSPm - PLURIJET 80/130	VSP - PLURIJET 80/130				497		191												21.9	21.9
-	VSP - PLURIJET 105/130				523		217	75		260	145	59	242	129	113	185	145	11	-	24.1
VSPm - PLURIJET 70/200	VSP - PLURIJET 70/200				497		191												21.9	21.9
-	VSP - PLURIJET 95/200				523		217												-	24.0

VSP – MK

PERFORMANCE RANGE

50 Hz

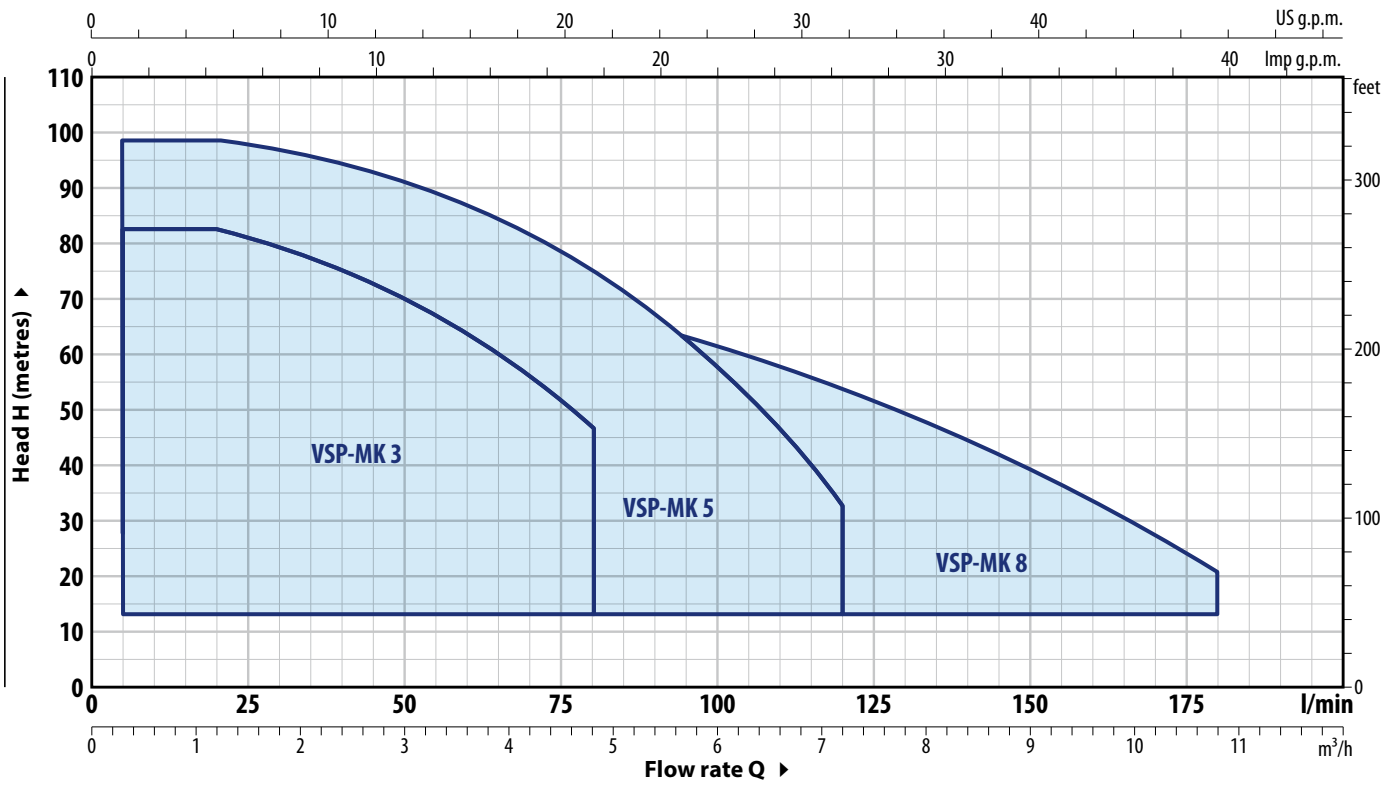

TECHNICAL DATA

TYPE	POWER		ABSORPTION 230 V	PERFORMANCE		PERFORMANCE (ADJUSTABLE SET POINT)					
	P ₂ kW	HP		Q litres/min	H metres	Set Point Min		Set Point Calibration Std		Set Point Max	
Single-phase						bar	l/min	bar	l/min	bar	l/min
VSPm - MK 3/3	0.75	1	6.2 A	10 – 80	52 – 29	1.4	5 – 52	4.0	5 – 52	5.0	5 – 14
VSPm - MK 3/5	1.1	1.5	7.8 A	10 – 80	85 – 48	2.3	5 – 52	4.0	5 – 72	8.3	5 – 13
VSPm - MK 3/6	1.5	2	9.0 A	10 – 80	101 – 56	2.7	5 – 53	4.0	5 – 65	9.7	5 – 19
VSPm - MK 5/4	0.75	1	6.4 A	20 – 120	55 – 20	1.5	5 – 101	4.0	5 – 82	5.3	5 – 26
VSPm - MK 5/5	1.1	1.5	6.5 A	20 – 120	69 – 21.5	1.8	5 – 108	4.0	5 – 99	6.7	5 – 13
VSPm - MK 5/7	1.5	2	9.0 A	20 – 120	95 – 30	2.6	5 – 109	4.0	5 – 111	9.3	5 – 16
VSPm - MK 8/4	1.1	1.5	8.3 A	40 – 180	53 – 12	1.4	5 – 175	4.0	5 – 115	5.2	5 – 30
VSPm - MK 8/5	1.5	2	10.0 A	40 – 180	68 – 15.5	1.8	5 – 175	4.0	5 – 138	6.6	5 – 45

TYPE	POWER		ABSORPTION 400 V	PERFORMANCE		PERFORMANCE (ADJUSTABLE SET POINT)					
	P ₂ kW	HP		Q litres/min	H metres	Set Point Min		Set Point Calibration Std		Set Point Max	
Three-phase						bar	l/min	bar	l/min	bar	l/min
VSP - MK 3/3	0.75	1	1.7 A	10 – 80	52 – 29	1.4	5 – 52	4.0	5 – 52	5.0	5 – 14
VSP - MK 3/5	1.1	1.5	2.3 A	10 – 80	85 – 48	2.3	5 – 52	4.0	5 – 72	8.3	5 – 13
VSP - MK 3/6	1.5	2	2.8 A	10 – 80	101 – 56	2.7	5 – 53	4.0	5 – 65	9.7	5 – 19
VSP - MK 5/4	0.75	1	2.0 A	20 – 120	55 – 20	1.5	5 – 101	4.0	5 – 82	5.3	5 – 26
VSP - MK 5/5	1.1	1.5	2.2 A	20 – 120	69 – 21.5	1.8	5 – 108	4.0	5 – 99	6.7	5 – 13
VSP - MK 5/7	1.5	2	3.0 A	20 – 120	95 – 30	2.6	5 – 109	4.0	5 – 111	9.3	5 – 16
VSP - MK 5/8	2.2	3	3.5 A	20 – 120	108 – 34	2.9	5 – 109	4.0	5 – 115	10.6	5 – 14
VSP - MK 8/4	1.1	1.5	2.8 A	40 – 180	53 – 12	1.4	5 – 175	4.0	5 – 115	5.2	5 – 30
VSP - MK 8/5	1.5	2	3.4 A	40 – 180	68 – 15.5	1.8	5 – 175	4.0	5 – 138	6.6	5 – 45
VSP - MK 8/6	2.2	3	3.8 A	40 – 180	81 – 18.5	2.2	5 – 175	4.0	5 – 149	8.0	5 – 22

PERFORMANCE CURVES

50 Hz

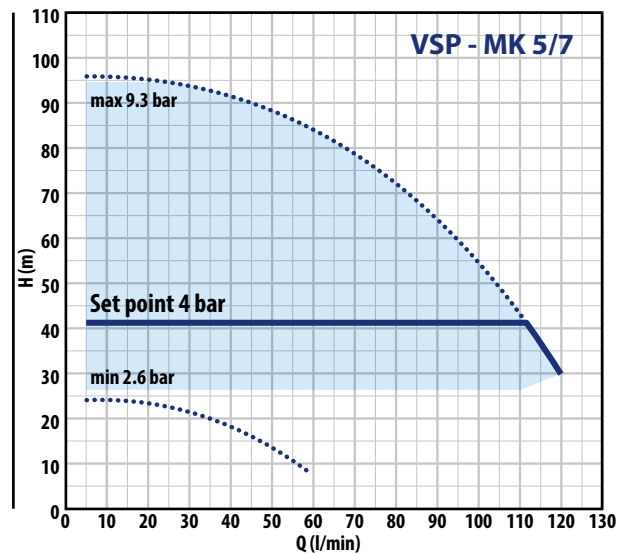
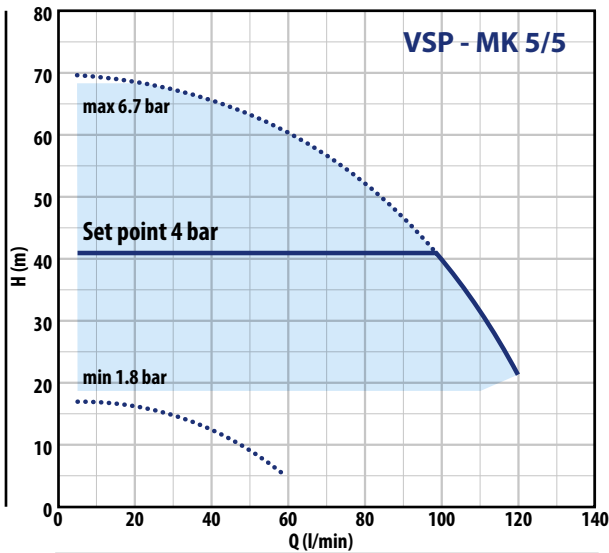
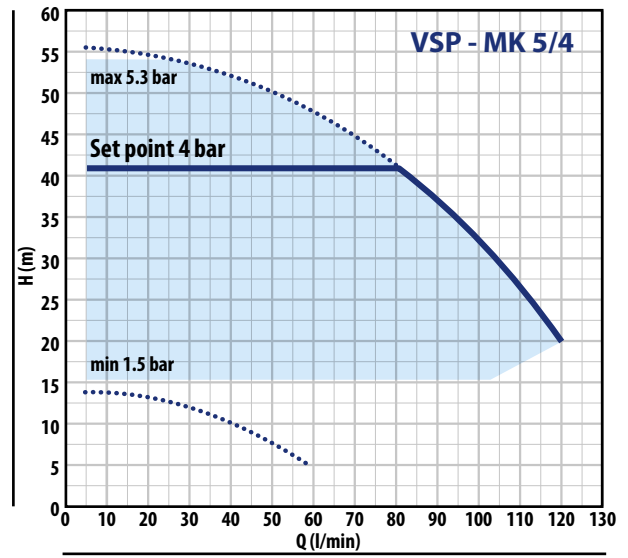
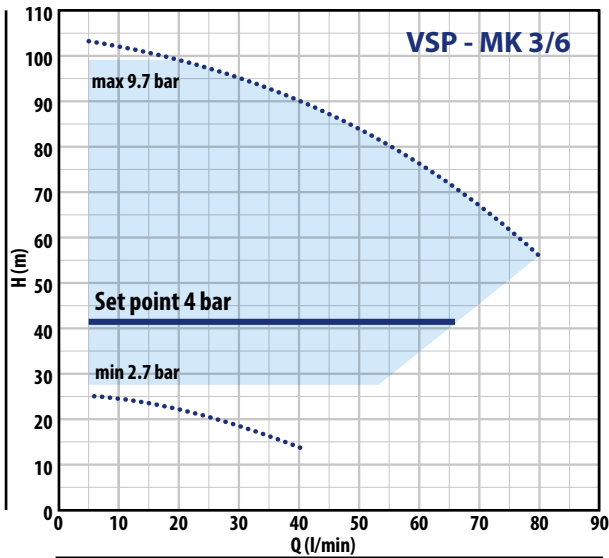
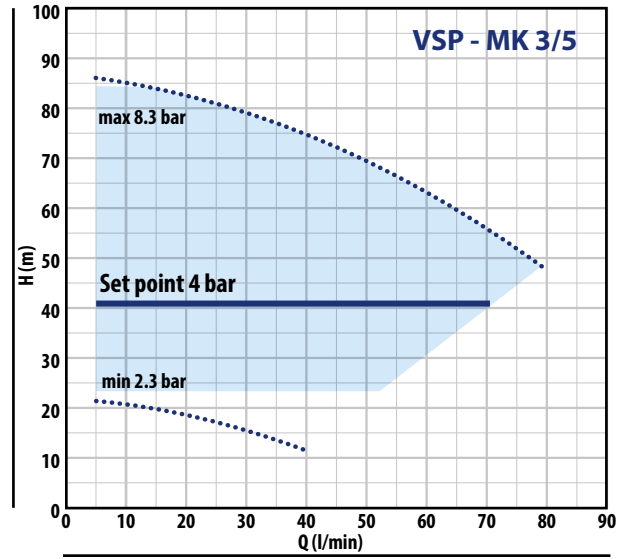
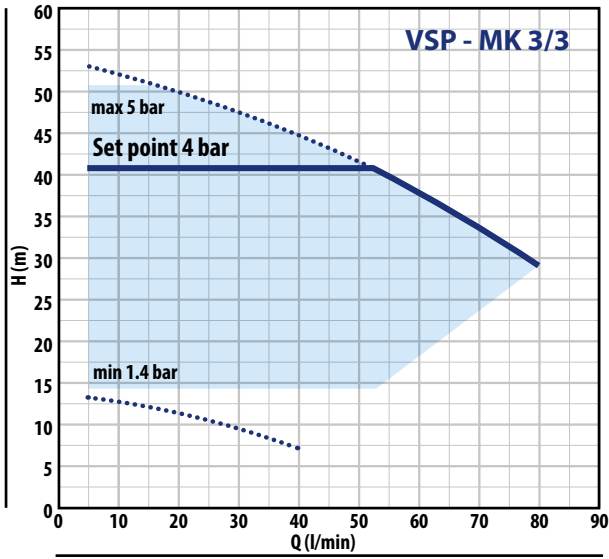

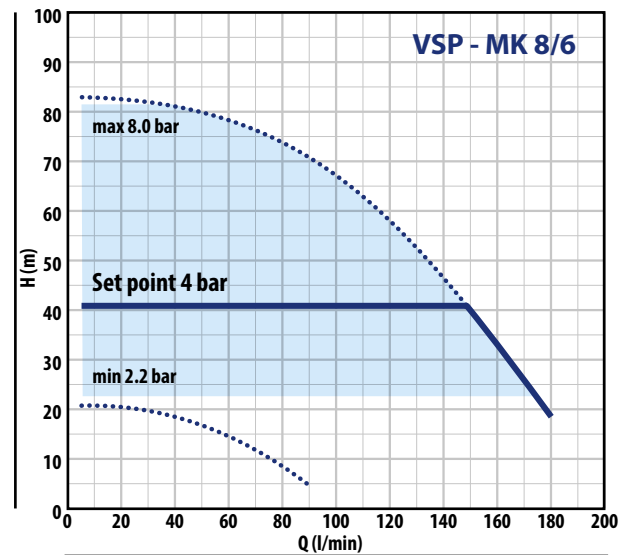
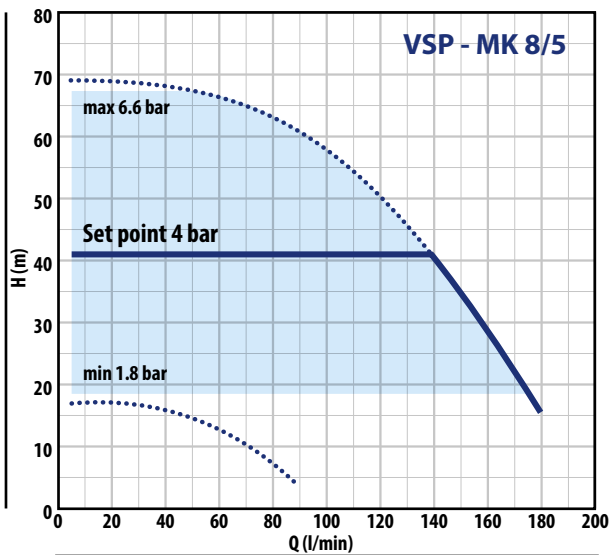
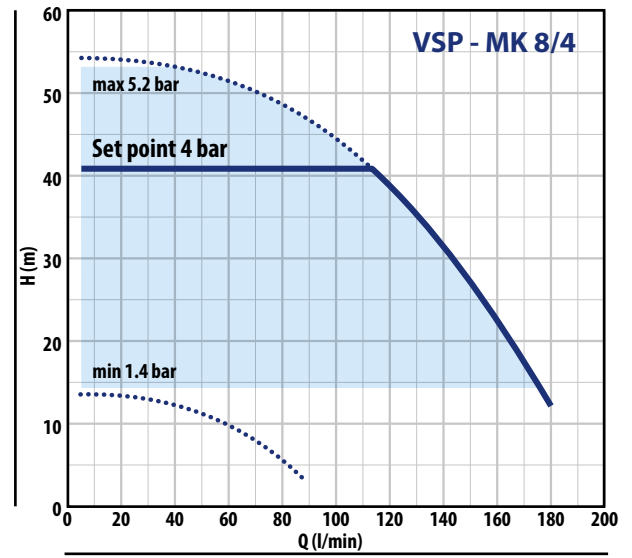
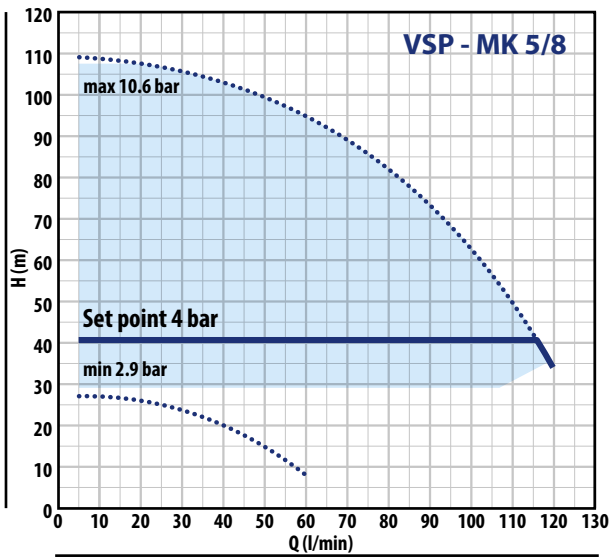

DIMENSIONS AND WEIGHT

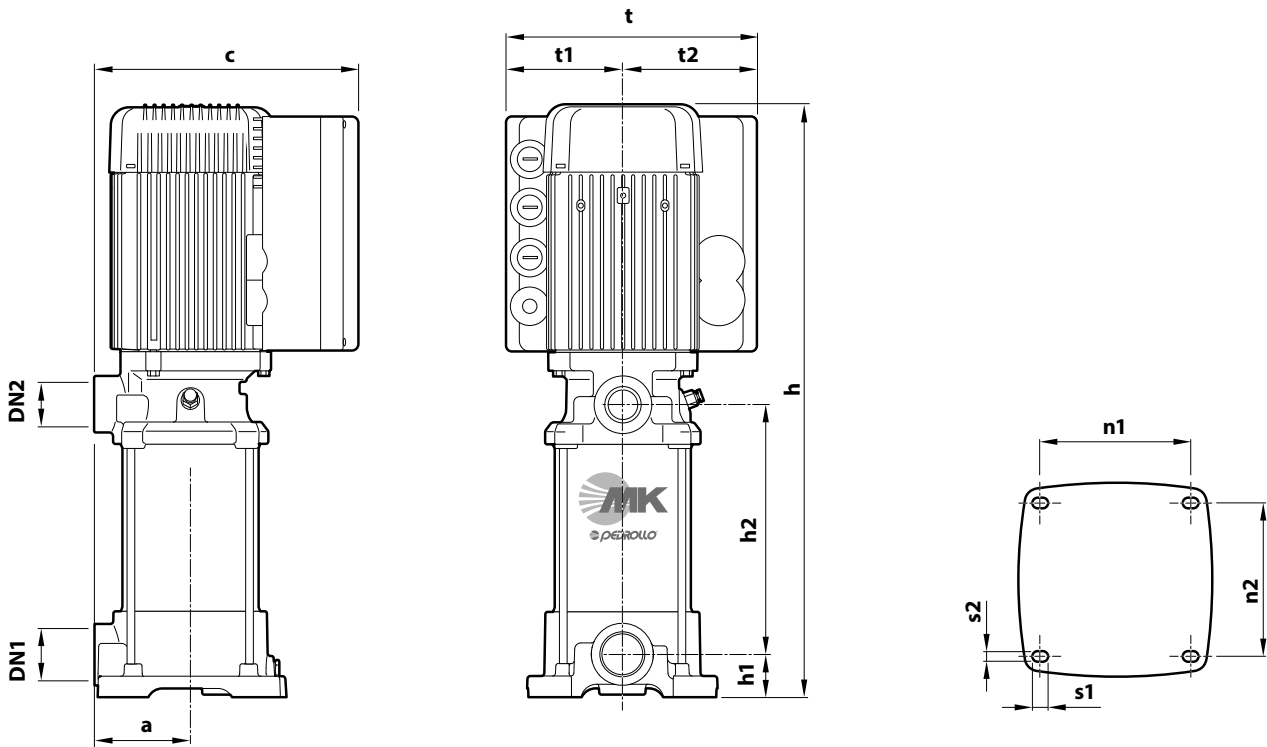

Single-phase	TYPE		PORTS		DIMENSIONS mm										kg		
	Three-phase	DN1	DN2	a	c	h	h1	h2	t	t1	t2	n1	n2	s1	s2	1~	3~
VSPm - MK 3/3	VSP - MK 3/3	1 1/4"	1"	93	255	447	41	132	242	113	129	143	146	14.5	10	23.3	23.3
VSPm - MK 3/5	VSP - MK 3/5					501		186								25.5	25.5
VSPm - MK 3/6	VSP - MK 3/6					528		213								27.3	27.3
VSPm - MK 5/4	VSP - MK 5/4					474		159								23.8	23.8
VSPm - MK 5/5	VSP - MK 5/5					501		186								25.2	25.2
VSPm - MK 5/7	VSP - MK 5/7					555		240								28.3	28.3
-	VSP - MK 5/8					602		267								-	28.6
VSPm - MK 8/4	VSP - MK 8/4					474		159								26.6	26.6
VSPm - MK 8/5	VSP - MK 8/5					501		186								27.0	27.0
-	VSP - MK 8/6					548		213								-	29.4

VSP – HT-PRO

PERFORMANCE RANGE

50 Hz

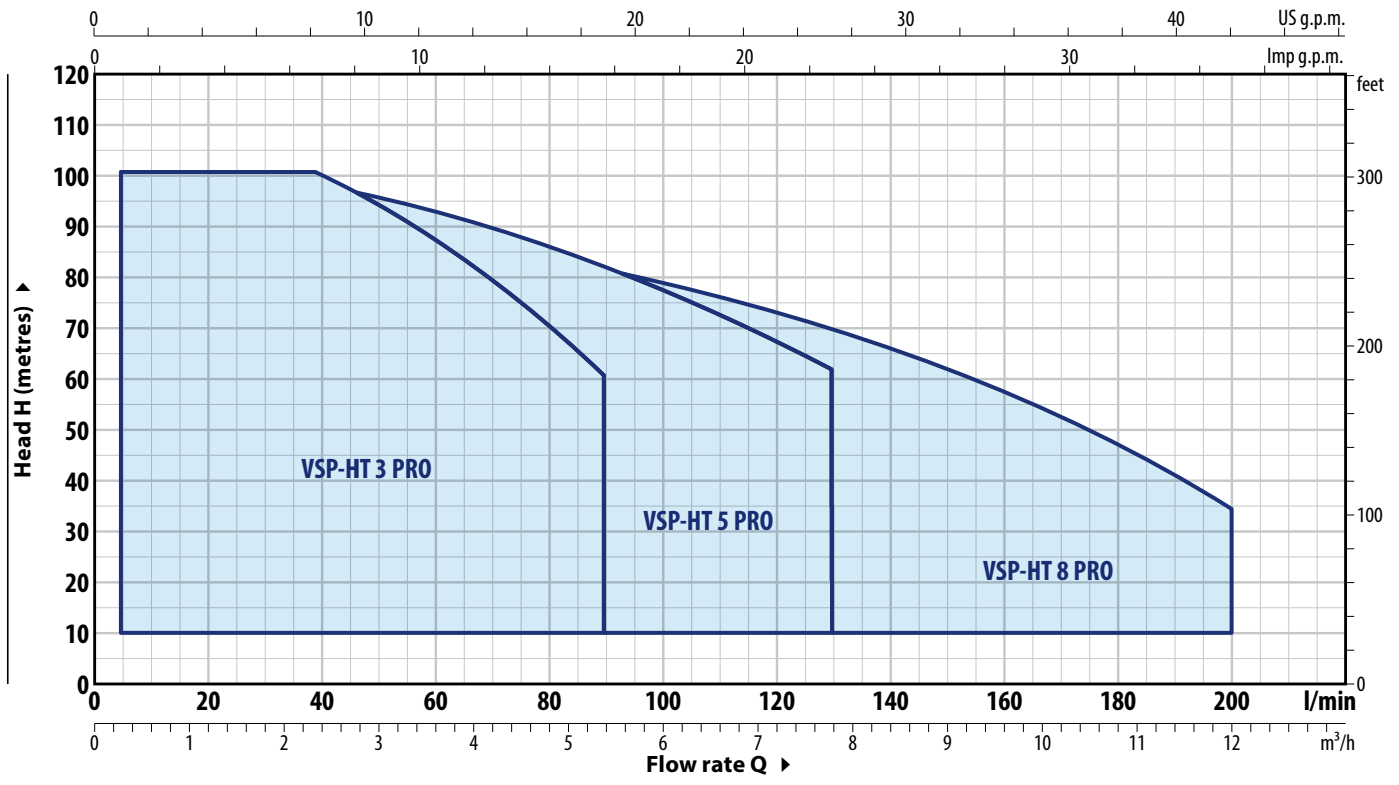

TECHNICAL DATA

TYPE	POWER		ABSORPTION 230 V	PERFORMANCE		PERFORMANCE (ADJUSTABLE SET POINT)					
	P ₂			Q	H	Set Point Min		Set Point Calibration Std		Set Point Max	
Single-phase	kW	HP		litres/min	metres	bar	l/min	bar	l/min	bar	l/min
VSPm - HT 3/4 PRO	0.75	1	7.5 A	5 – 90	65 – 35	1.6	5 – 59	4.0	5 – 73	5.9	5 – 19
VSPm - HT 3/5 PRO	1.1	1.5	9.0 A	5 – 90	80 – 44	2.0	5 – 62	4.0	5 – 86	7.4	5 – 22
VSPm - HT 3/6 PRO	1.5	2	10.5 A	5 – 90	96 – 52	2.4	5 – 62	4.0	5 – 84	8.8	5 – 20
VSPm - HT 5/2 PRO	0.75	1	7.0 A	5 – 130	35 – 20.5	0.8	5 – 83	2.0	5 – 114	3.1	5 – 22
VSPm - HT 5/3 PRO	1.1	1.5	8.0 A	5 – 130	51.5 – 31	1.3	5 – 91	4.0	5 – 71	4.8	5 – 14
VSPm - HT 5/4 PRO	1.5	2	9.5 A	5 – 130	68.5 – 41	1.7	5 – 90	4.0	5 – 108	6.1	5 – 26
VSPm - HT 8/3 PRO	1.1	1.5	8.5 A	20 – 200	46.5 – 17	1.1	5 – 182	4.0	5 – 58	4.1	5 – 28
VSPm - HT 8/4 PRO	1.5	2	10.0 A	20 – 200	62 – 23	1.5	5 – 180	4.0	5 – 128	5.4	5 – 48

TYPE	POWER		ABSORPTION 400 V	PERFORMANCE		PERFORMANCE (ADJUSTABLE SET POINT)					
	P ₂			Q	H	Set Point Min		Set Point Calibration Std		Set Point Max	
Three-phase	kW	HP		litres/min	metres	bar	l/min	bar	l/min	bar	l/min
VSP - HT 3/4 PRO	0.75	1	2.5 A	5 – 90	65 – 35	1.6	5 – 59	4.0	5 – 73	5.9	5 – 19
VSP - HT 3/5 PRO	1.1	1.5	3.0 A	5 – 90	80 – 44	2.0	5 – 62	4.0	5 – 86	7.4	5 – 22
VSP - HT 3/6 PRO	1.5	2	3.5 A	5 – 90	96 – 52	2.4	5 – 62	4.0	5 – 84	8.8	5 – 20
VSP - HT 3/7 PRO	1.8	2.5	4.2 A	5 – 90	112 – 61	2.8	5 – 62	4.0	5 – 76	10.2	5 – 25
VSP - HT 5/2 PRO	0.75	1	2.3 A	5 – 130	35 – 20.5	0.8	5 – 83	2.0	5 – 114	3.1	5 – 22
VSP - HT 5/3 PRO	1.1	1.5	2.4 A	5 – 130	51.5 – 31	1.3	5 – 91	4.0	5 – 71	4.8	5 – 14
VSP - HT 5/4 PRO	1.5	2	3.2 A	5 – 130	68.5 – 41	1.7	5 – 90	4.0	5 – 108	6.1	5 – 26
VSP - HT 5/5 PRO	1.8	2.5	4.0 A	5 – 130	85 – 51.5	2.1	5 – 91	4.0	5 – 128	7.5	5 – 42
VSP - HT 5/6 PRO	2.2	3	4.3 A	5 – 130	103 – 62	2.6	5 – 92	4.0	5 – 118	9.3	5 – 25
VSP - HT 8/3 PRO	1.1	1.5	3.0 A	20 – 200	46.5 – 17	1.1	5 – 182	4.0	5 – 58	4.1	5 – 28
VSP - HT 8/4 PRO	1.5	2	3.4 A	20 – 200	62 – 23	1.5	5 – 180	4.0	5 – 128	5.4	5 – 48
VSP - HT 8/5 PRO	1.8	2.5	4.0 A	20 – 200	77.5 – 28.5	1.8	5 – 181	4.0	5 – 156	6.7	5 – 44
VSP - HT 8/6 PRO	2.2	3	4.5 A	20 – 200	93 – 34.5	2.3	5 – 186	4.0	5 – 179	8.2	5 – 32

PERFORMANCE CURVES

50 Hz

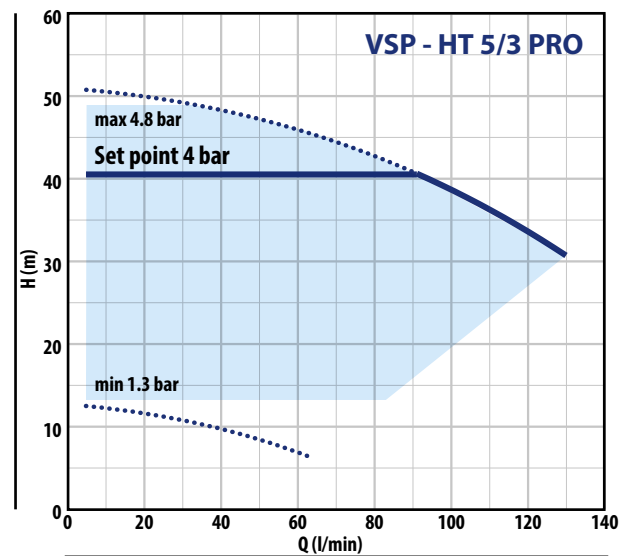
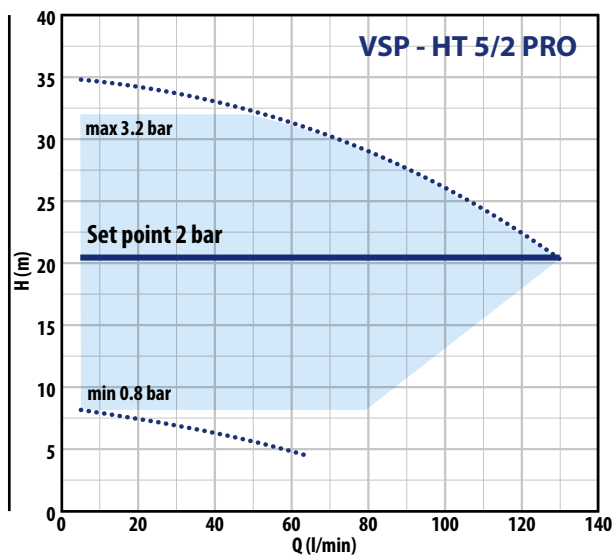
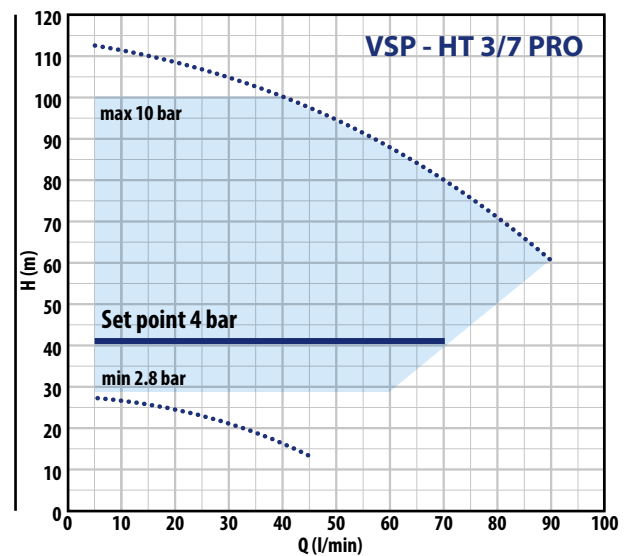
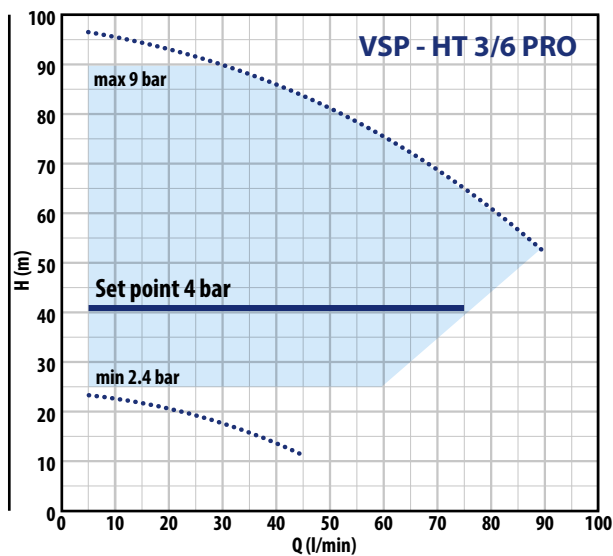
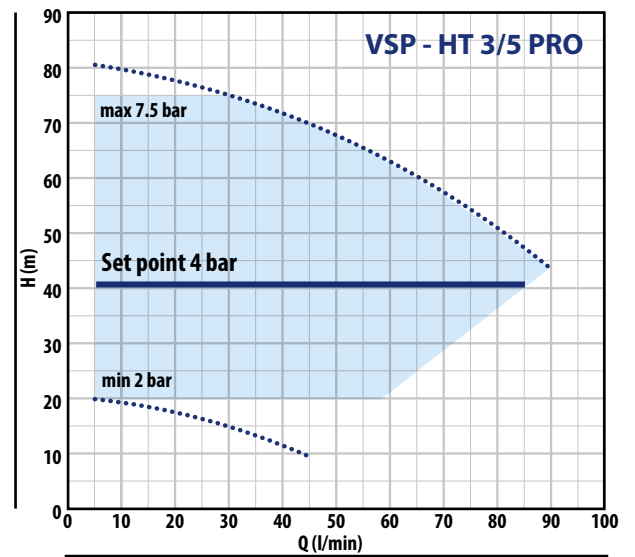
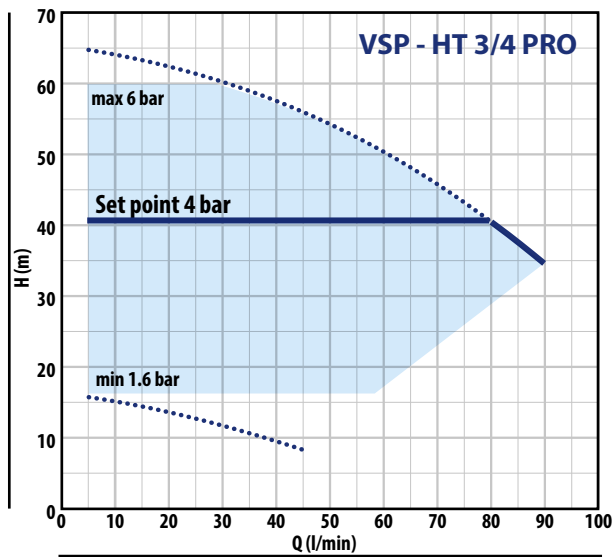

VSP - HT-PRO

PERFORMANCE CURVES

50 Hz

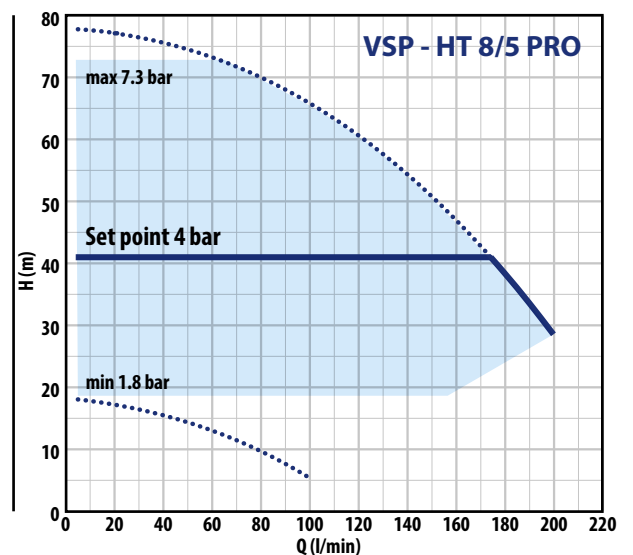
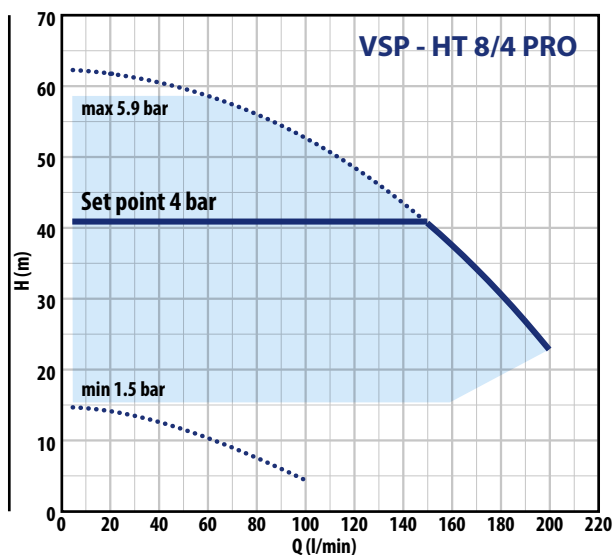
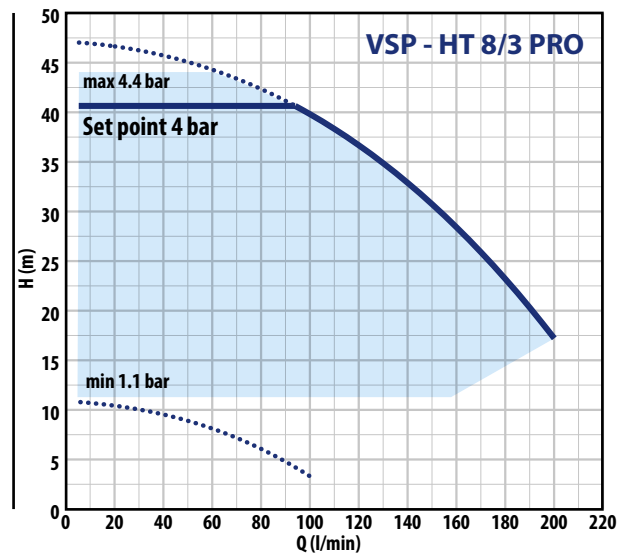
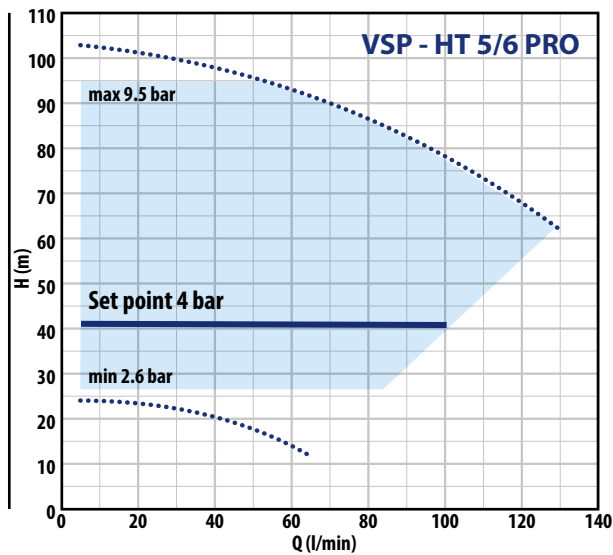
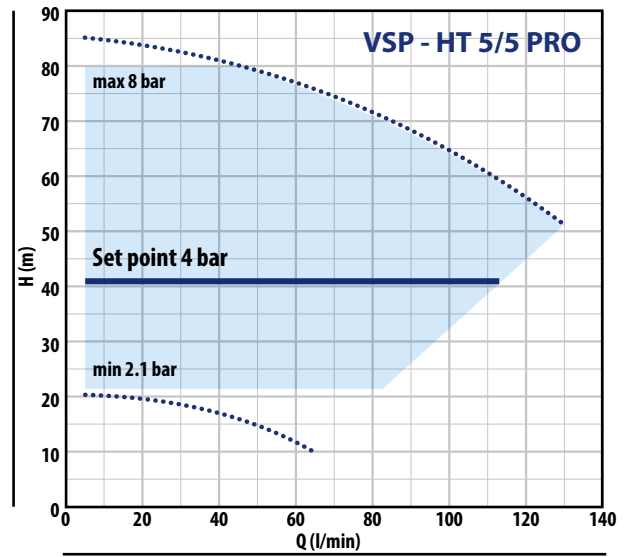
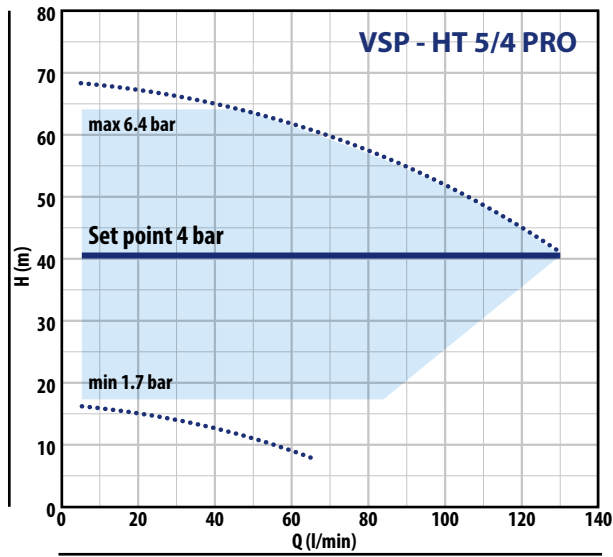

PERFORMANCE CURVES

50 Hz

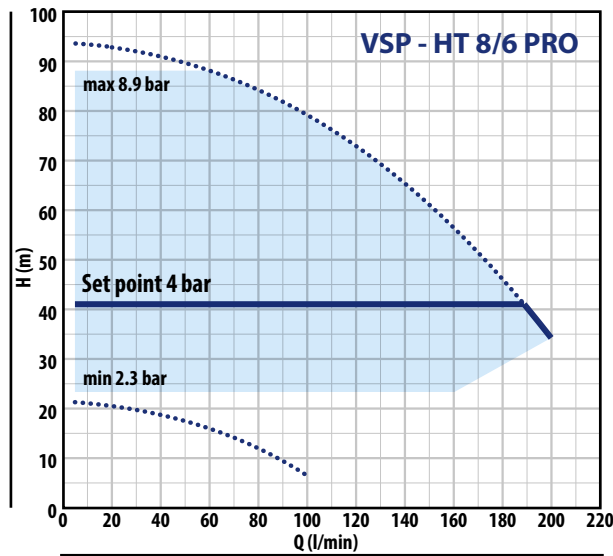

DIMENSIONS AND WEIGHT

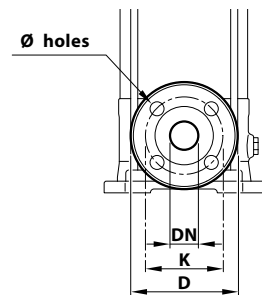
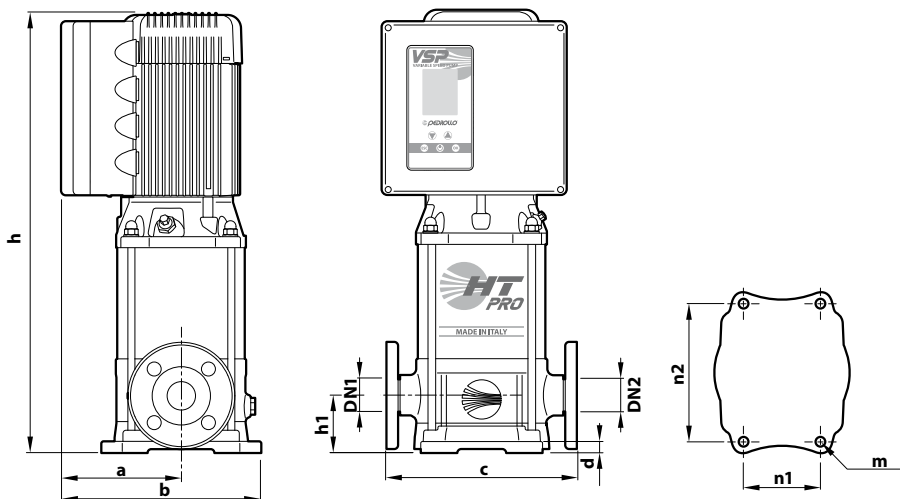

TYPE	DN	D	K	Ø
VSP	mm	mm	mm	mm
HT 3	25	115	85	14
HT 5	32	140	100	18
HT 8	40	150	110	

TYPE		PORTS		DIMENSIONS mm									kg	
Single-phase	Three-phase	DN1	DN2	a	b	c	d	h	h1	n1	n2	m	1~	3~
VSPm - HT 3/4 PRO	VSP - HT 3/4 PRO	1"	1"					509					35.3	34.8
VSPm - HT 3/5 PRO	VSP - HT 3/5 PRO							535					35.5	35.0
VSPm - HT 3/6 PRO	VSP - HT 3/6 PRO							561					36.2	37.1
-	VSP - HT 3/7 PRO							607					-	41.2
VSPm - HT 5/2 PRO	VSP - HT 5/2 PRO	1 1/4"	1 1/4"	164	269	212	15	457	75	100	180	Ø 13	33.2	33.2
VSPm - HT 5/3 PRO	VSP - HT 5/3 PRO							483					33.4	33.4
VSPm - HT 5/4 PRO	VSP - HT 5/4 PRO							509	35.3				35.4	
-	VSP - HT 5/5 PRO							555	-				39.1	
-	VSP - HT 5/6 PRO	581	-	40.1										
VSPm - HT 8/3 PRO	VSP - HT 8/3 PRO	1 1/2"	1 1/2"			240		488	80				33.9	33.9
VSPm - HT 8/4 PRO	VSP - HT 8/4 PRO							514					35.8	35.9
-	VSP - HT 8/5 PRO							560					-	39.4
-	VSP - HT 8/6 PRO							586					-	40.2

-  Clean water
-  Domestic use
-  Civil use



INSTALLATION AND USE

VSP2 is a pre-assembled system intended for connecting to water mains or a primary collection tank. It provides water supply and pressurization and is ideal for residential, commercial, and public buildings. It's also suitable for hotels, park irrigation, as well as industrial water handling and treatment.

VSP2 is compatible with clean water and aqueous solutions that do not chemically or mechanically harm the materials used and are free from abrasive or fibrous substances.

PRODUCT DESCRIPTION

VSP2 is a pressurization system comprising two pumping units connected in parallel. Integrated inverter devices automatically adjust their operation to varying water demands while ensuring constant pressure.

When system pressure drops due to water withdrawal, the first **VSP** unit starts working to provide the necessary water flow rate, maintaining pressure. Once the maximum rotation speed is reached, the second **VSP** unit starts to fulfill the system's water demand.

COMPONENTS

✘ **TWO VSP PUMPING UNITS** connected in parallel via suction and discharge manifolds. Each unit is equipped with ball valves on the supply and suction side, non-return valves on the suction side (FCR, PLURIJET, MK) or on the supply side (HT-PRO). The electronics integrated in VSP can manage the alternating operation of individual units.

VSP2 is designed to protect the system from:

- ✘ dry running
- ✘ overvoltage and undervoltage
- ✘ combustion chamber

✘ **BASE** made of metal profile and equipped with adjustable vibration-damping feet.

✘ **PRESSURE TRANSDUCER** (4-20mA) installed on the supply manifold, which enables command and control of the pressurization unit.

✘ **ELECTRICAL PANEL** with thermal-magnetic circuit breakers for three-phase versions and thermal-magnetic circuit breakers for single-phase versions.



VSP2 – FCR

Pressurization units comprise two multistage centrifugal pumps with an integrated inverter in the motor, capable of maintaining constant pressure in the system. They are used for water supply in residential, commercial, and public buildings, as well as for garden irrigation and general clean water movement.

TECHNICAL DATA

- Liquid temperature between **-10 °C** and **+60 °C**
- Ambient temperature between **-5 °C** and **+40 °C**
- Max. pressure in the pump body **10 bar**
- Continuous running duty **S1**



VSP2 – PLURIJET

Pressurization units comprise two self-priming multistage centrifugal pumps with an integrated inverter in the motor, capable of maintaining a constant pressure in the system. They are utilized for water supply, including from underground reservoirs, in residential, commercial, and public buildings, as well as for garden irrigation and general clean water movement.

TECHNICAL DATA

- Liquid temperature between **-10 °C** and **+40 °C**
- Ambient temperature between **-5 °C** and **+40 °C**
- Max. pressure in the pump body **10 bar**
- Continuous running duty **S1**



VSP2 – MK

Pressurization units comprise two vertical multistage pumps with an integrated inverter in the motor, capable of maintaining a constant pressure in the system. They are used for water supply in residential, commercial, and public buildings, as well as for handling clean water.

TECHNICAL DATA

- Liquid temperature between **-10 °C** and **+60 °C**
- Ambient temperature between **-5 °C** and **+40 °C**
- Max. pressure in pump body **11 bar**
- Continuous running duty **S1**



VSP2 - HT PRO

Pressurization units comprise two vertical multistage pumps with integrated inverters in the motor to maintain consistent pressure in the system. They're commonly used for water supply in commercial and public buildings, irrigation in parks and athletic fields, and for industrial water treatment.

TECHNICAL DATA

- Liquid temperature between **-10 °C** and **+60 °C**
- Ambient temperature between **-5 °C** and **+40 °C**
- Max. pressure in pump body **11 bar**
- Continuous running duty **S1**

VSP2 – FCR

FIELD AND PERFORMANCE DATA

50 Hz

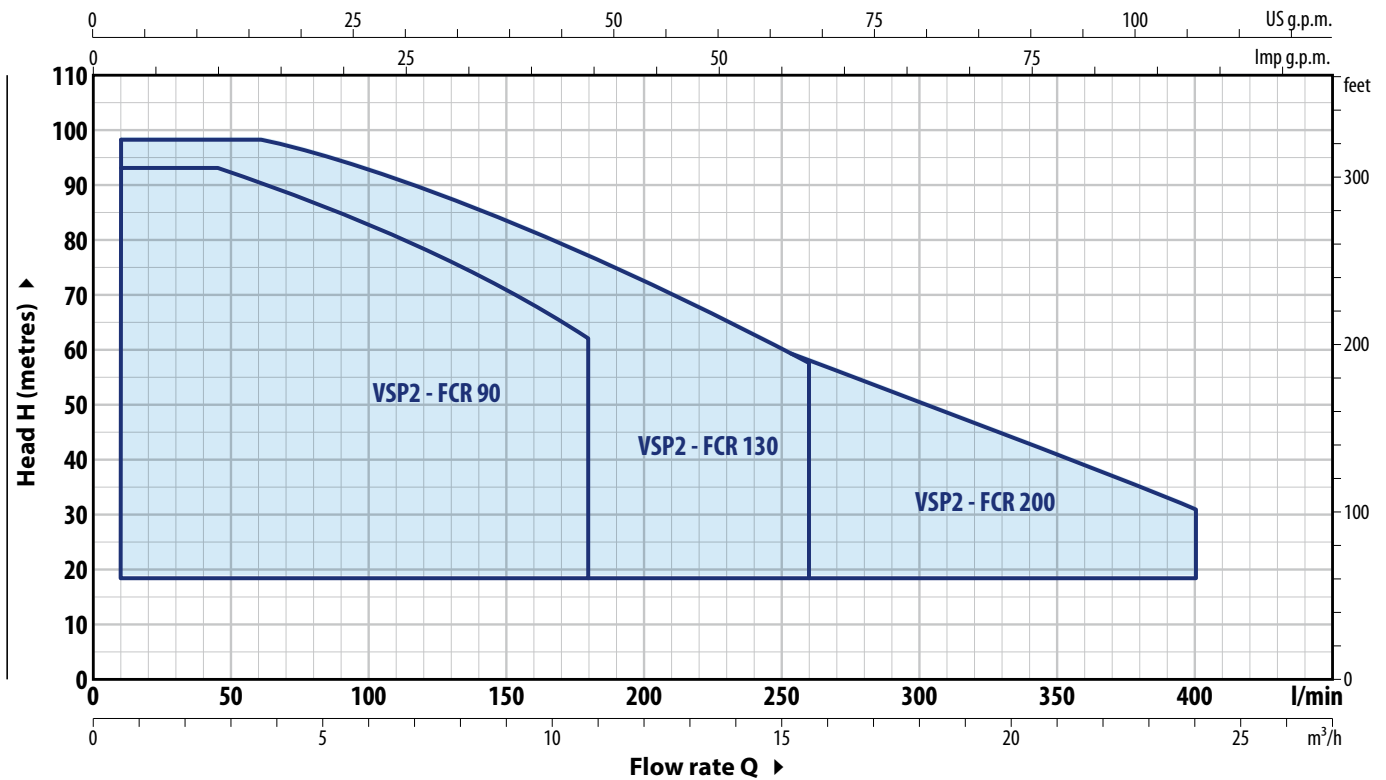

TYPE	POWER P ₂		Q	Flow rate															
	kW	HP		m ³ /h	0	0.6	1.2	2.4	4.8	6	7.2	9.6	10.8	12	14.4	15.6	18	20.4	24
Single-phase				0	10	20	40	80	100	120	160	180	200	240	260	300	340	400	
VSP2m - FCR 75/90	2x1.5	2x2	H metres	71.5	71.5	71.5	71	66	63	59.5	49.5	43.5							
VSP2m - FCR 80/130	2x1.5	2x2		74.5	74.5	74.5	74.5	69.5	66	62	52.5	48	43	34	30				
VSP2m - FCR 70/200	2x1.5	2x2		65.5	65.5	65.5	65.5	65	62.5	60	53.5	50	46	38.5	35	27.5	21	14	

TYPE	POWER P ₂		Q	Flow rate															
	kW	HP		m ³ /h	0	0.6	1.2	2.4	4.8	6	7.2	9.6	10.8	12	14.4	15.6	18	20.4	24
Three-phase				0	10	20	40	80	100	120	160	180	200	240	260	300	340	400	
VSP2 - FCR 75/90	2x1.5	2x2	H metres	71.5	71.5	71.5	71	66	63	59.5	49.5	43.5							
VSP2 - FCR 100/90	2x2.2	2x3		94	94	94	94	87.5	83	78.5	68	62.5							
VSP2 - FCR 80/130	2x1.5	2x2		74.5	74.5	74.5	74.5	69.5	66	62	52.5	48	43	34	30				
VSP2 - FCR 105/130	2x2.2	2x3		98	98	98	98	96	93	89.5	81	76.5	72	62	57.5				
VSP2 - FCR 70/200	2x1.5	2x2		65.5	65.5	65.5	65.5	65	62.5	60	53.5	50	46	38.5	35	27.5	21	14	
VSP2 - FCR 95/200	2x2.2	2x3		87.5	87.5	87.5	87.5	87	85	82.5	76.5	73.5	70	62.5	58.5	50.5	42	31	

Q = Flow rate H = Total manometric head

Performance curves comply with EN ISO 9906 Grade 3B tolerance limits.

✘ The data shown in the diagram and tables indicate performance with 2 pumps in operation

PERFORMANCE CURVES

50 Hz

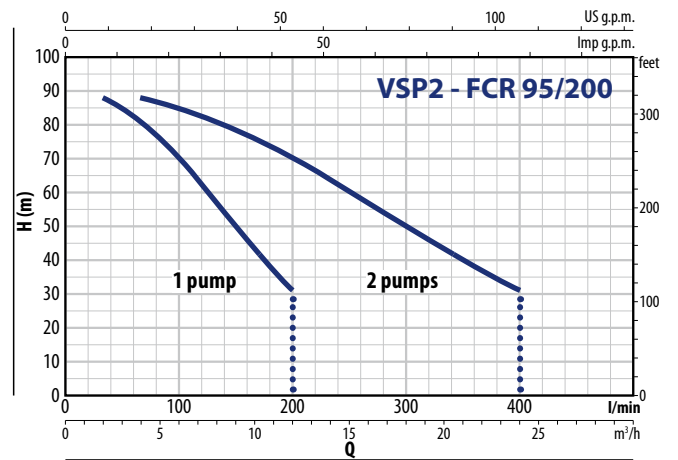
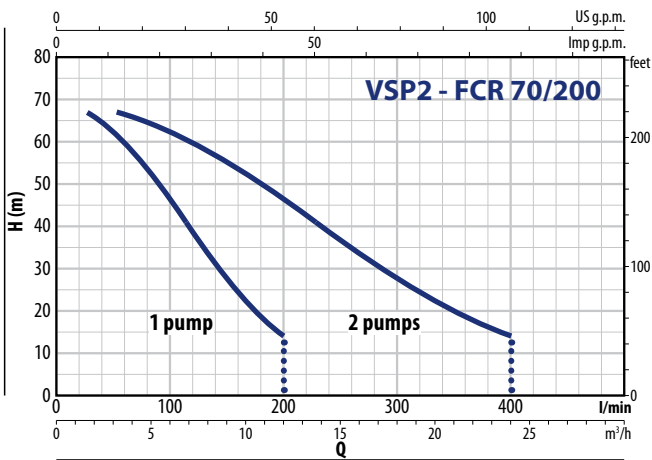
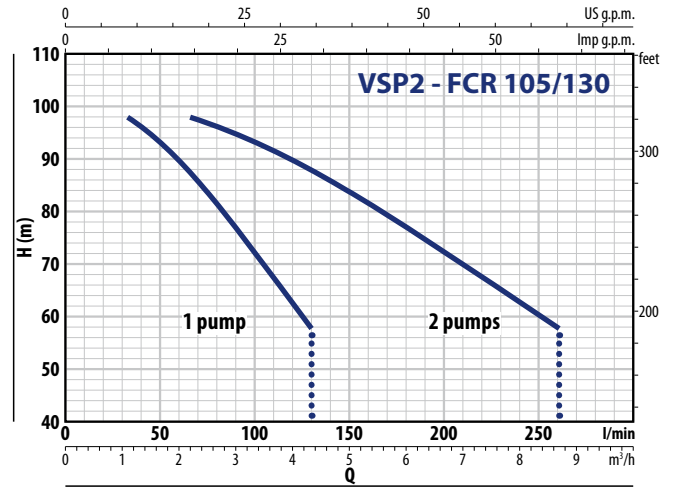
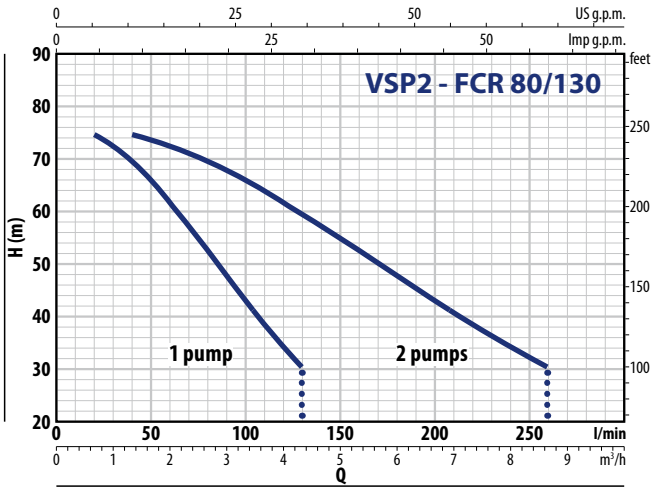
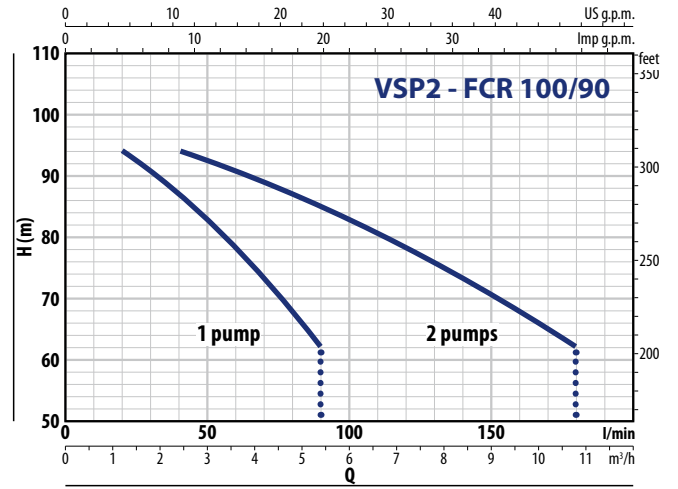
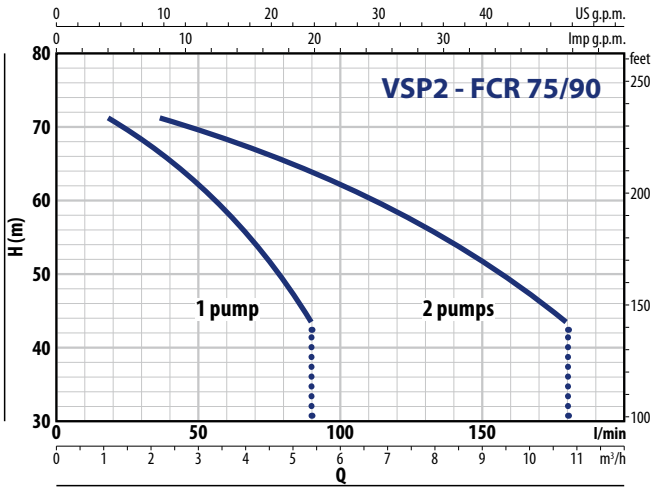

VSP2 - FCR

ABSORPTION

TYPE	VOLTAGE
Single-phase	230 V
VSP2m - FCR 75/90	2 x 9.8 A
VSP2m - FCR 80/130	2 x 9.8 A
VSP2m - FCR 70/200	2 x 9.8 A

TYPE	VOLTAGE
Three-phase	400 V
VSP2 - FCR 75/90	2 x 3.6 A
VSP2 - FCR 100/90	2 x 4.9 A
VSP2 - FCR 80/130	2 x 3.6 A
VSP2 - FCR 105/130	2 x 4.9 A
VSP2 - FCR 70/200	2 x 3.6 A
VSP2 - FCR 95/200	2 x 4.9 A

DIMENSIONS AND WEIGHT

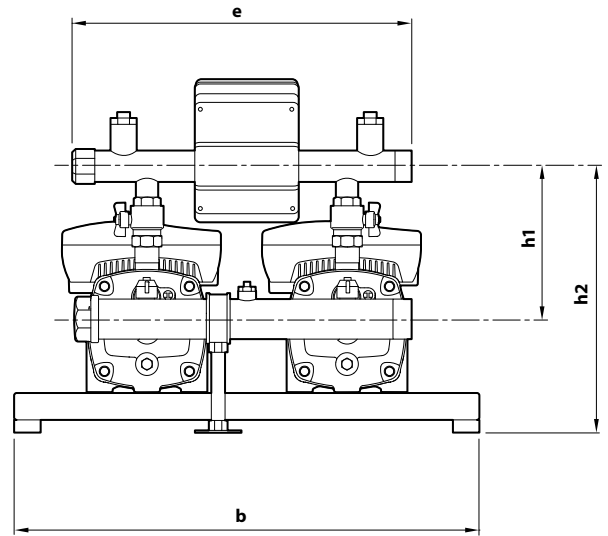
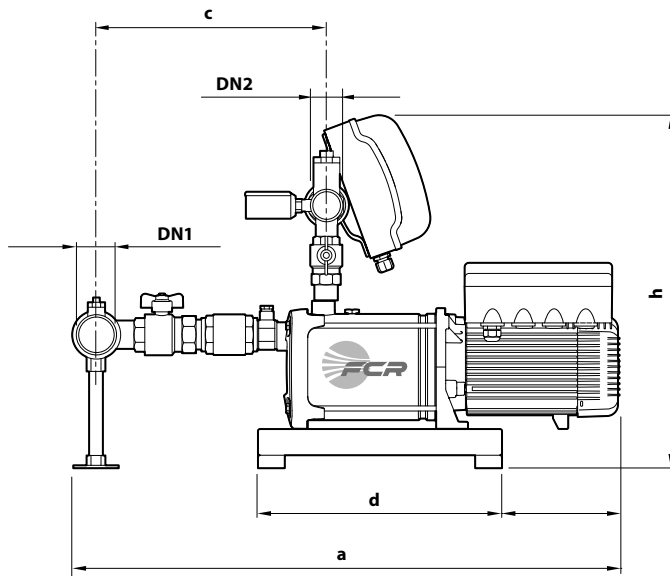

TYPE		PORTS		DIMENSIONS mm								kg	
Single-phase	Three-phase	DN1	DN2	a	b	c	d	e	h	h1	h2	1~	3~
VSP2m - FCR 75/90	VSP2 - FCR 75/90	2"	1½"	760	700	339	370	510	560	205	394	80	80
-	VSP2 - FCR 100/90			786								-	81
VSP2m - FCR 80/130	VSP2 - FCR 80/130			760								81	81
-	VSP2 - FCR 105/130			786								-	81
VSP2m - FCR 70/200	VSP2 - FCR 70/200	2½"	1½"	803	375							87	87
-	VSP2 - FCR 95/200			829								-	87

FIELD AND PERFORMANCE DATA

50 Hz

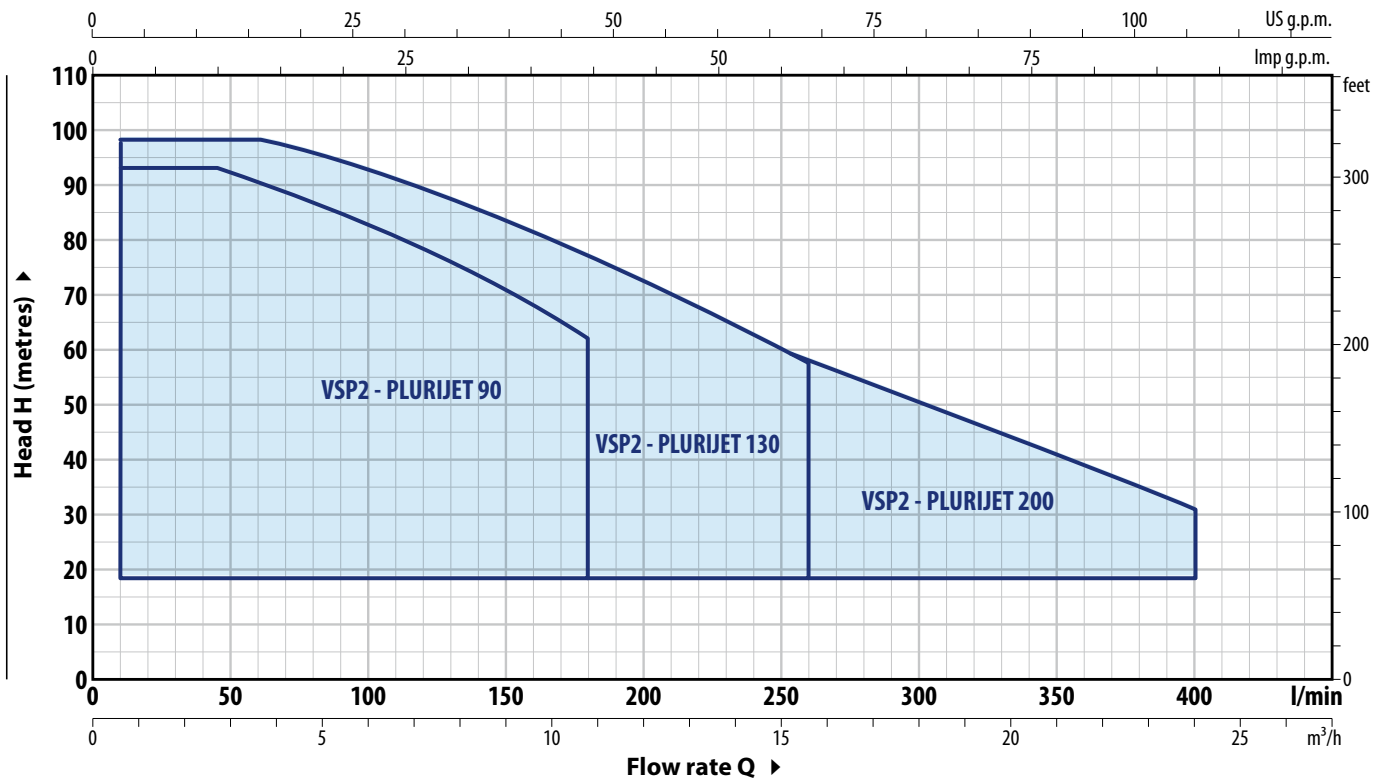

TYPE	POWER P ₂		Q	Flow rate															
	kW	HP		m ³ /h	0	0.6	1.2	2.4	4.8	6	7.2	9.6	10.8	12	14.4	15.6	18	20.4	24
Single-phase				0	10	20	40	80	100	120	160	180	200	240	260	300	340	400	
VSP2m - PLURIJET 75/90	2x1.5	2x2	H metres	71.5	71.5	71.5	71	66	63	59.5	49.5	43.5							
VSP2m - PLURIJET 80/130	2x1.5	2x2		74.5	74.5	74.5	74.5	69.5	66	62	52.5	48	43	34	30				
VSP2m - PLURIJET 70/200	2x1.5	2x2		65.5	65.5	65.5	65.5	65	62.5	60	53.5	50	46	38.5	35	27.5	21	14	

TYPE	POWER P ₂		Q	Flow rate															
	kW	HP		m ³ /h	0	0.6	1.2	2.4	4.8	6	7.2	9.6	10.8	12	14.4	15.6	18	20.4	24
Three-phase				0	10	20	40	80	100	120	160	180	200	240	260	300	340	400	
VSP2 - PLURIJET 75/90	2x1.5	2x2	H metres	71.5	71.5	71.5	71	66	63	59.5	49.5	43.5							
VSP2 - PLURIJET 100/90	2x2.2	2x3		94	94	94	94	87.5	83	78.5	68	62.5							
VSP2 - PLURIJET 80/130	2x1.5	2x2		74.5	74.5	74.5	74.5	69.5	66	62	52.5	48	43	34	30				
VSP2 - PLURIJET 105/130	2x2.2	2x3		98	98	98	98	96	93	89.5	81	76.5	72	62	57.5				
VSP2 - PLURIJET 70/200	2x1.5	2x2		65.5	65.5	65.5	65.5	65	62.5	60	53.5	50	46	38.5	35	27.5	21	14	
VSP2 - PLURIJET 95/200	2x2.2	2x3		87.5	87.5	87.5	87.5	87	85	82.5	76.5	73.5	70	62.5	58.5	50.5	42	31	

Q = Flow rate H = Total manometric head

Performance curves comply with EN ISO 9906 Grade 3B tolerance limits.

✘ The data shown in the diagram and tables indicate performance with 2 pumps in operation

VSP2 - PLURIJET

PERFORMANCE CURVES

50 Hz

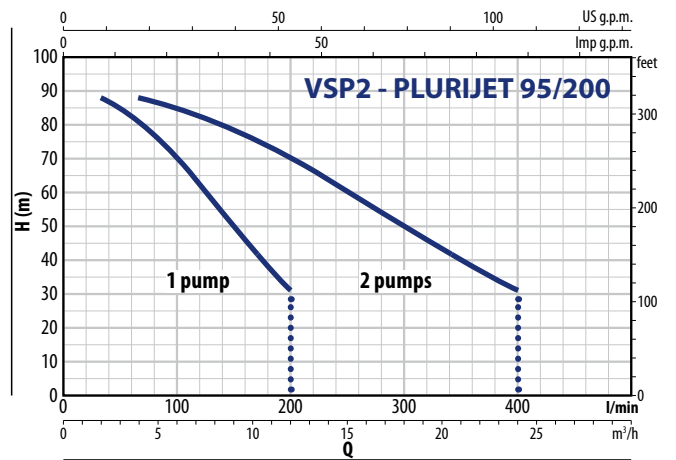
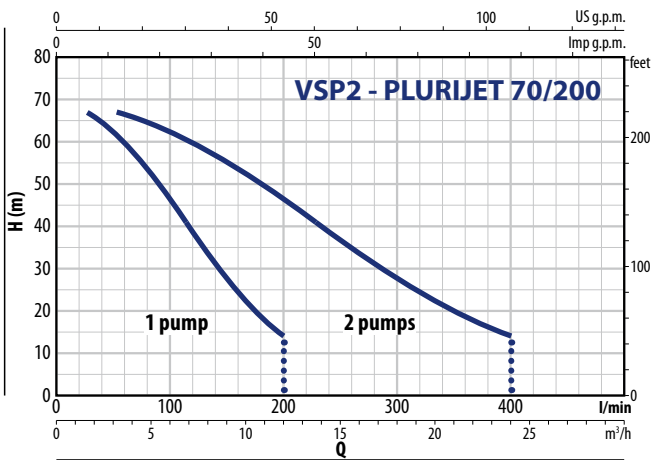
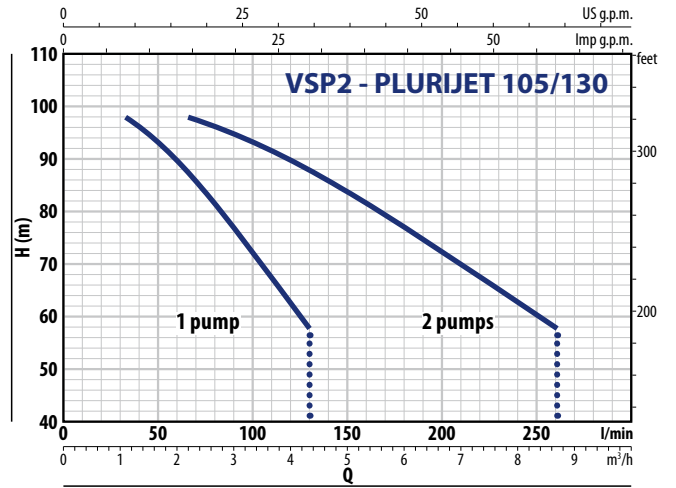
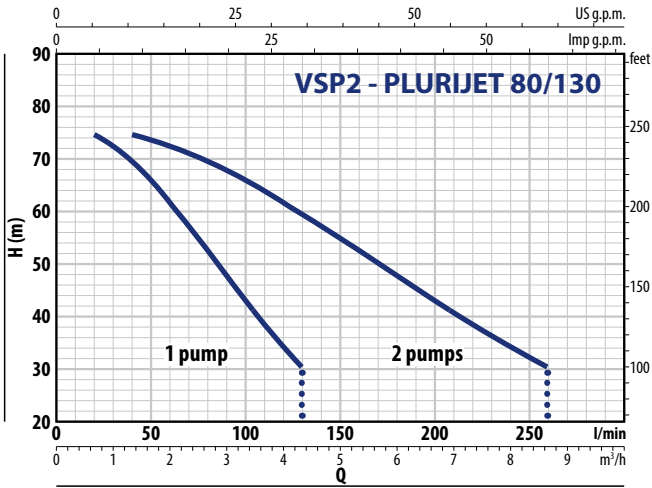
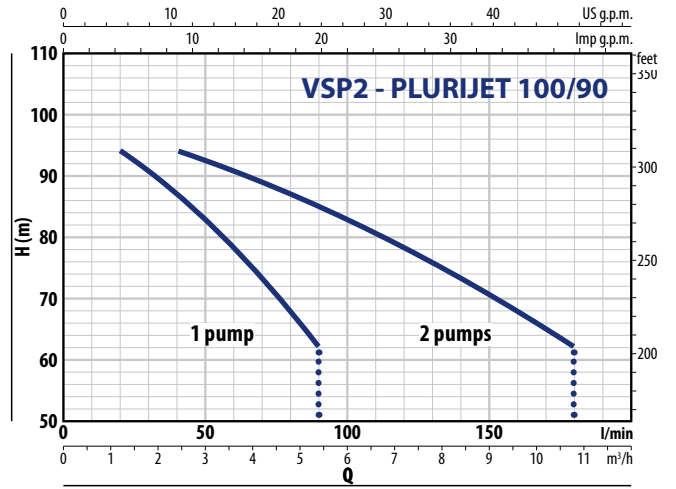
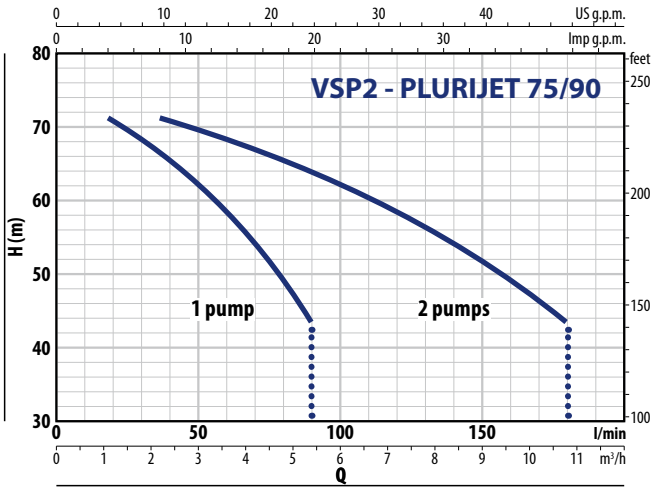

ABSORPTION

TYPE	VOLTAGE
Single-phase	230 V
VSP2m - PLURIJET 75/90	2 x 9.8 A
VSP2m - PLURIJET 80/130	2 x 9.8 A
VSP2m - PLURIJET 70/200	2 x 9.8 A

TYPE	VOLTAGE
Three-phase	400 V
VSP2 - PLURIJET 75/90	2 x 3.6 A
VSP2 - PLURIJET 100/90	2 x 4.9 A
VSP2 - PLURIJET 80/130	2 x 3.6 A
VSP2 - PLURIJET 105/130	2 x 4.9 A
VSP2 - PLURIJET 70/200	2 x 3.6 A
VSP2 - PLURIJET 95/200	2 x 4.9 A

DIMENSIONS AND WEIGHT

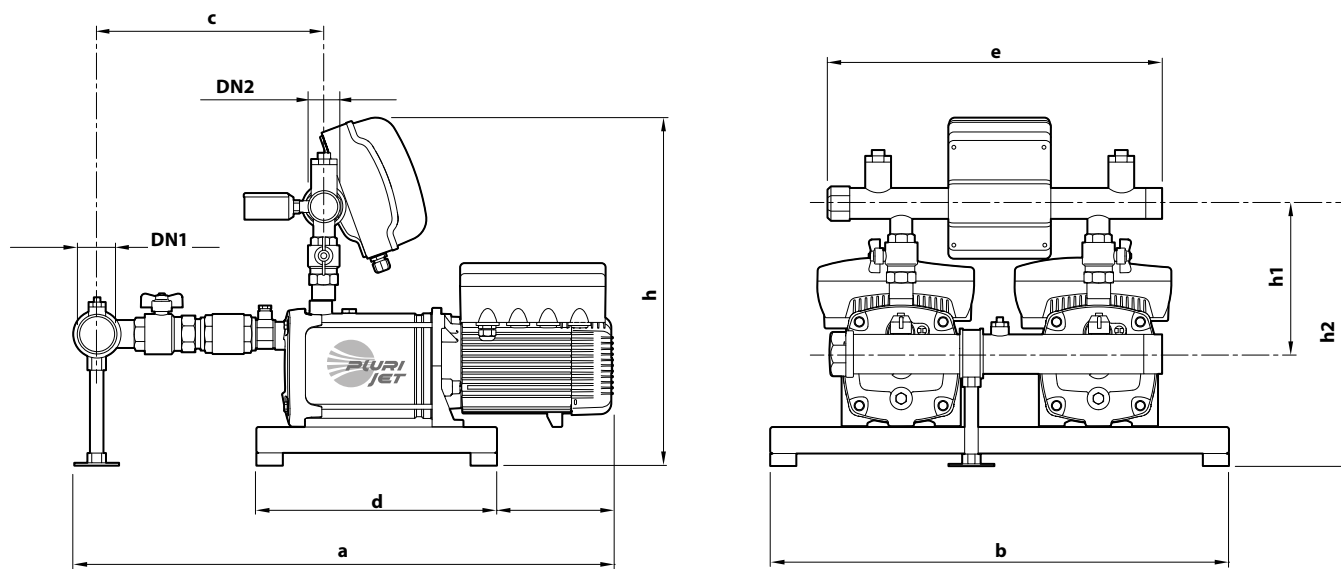

TYPE	PORTS	DIMENSIONS mm										kg		
		DN1	DN2	a	b	c	d	e	h	h1	h2	1~	3~	
Single-phase	Three-phase													
VSP2m - PLURIJET 75/90	VSP2 - PLURIJET 75/90	2"	1½"	812	700	339	370	510	560	205	394	80	80	
-	VSP2 - PLURIJET 100/90			838								-	85	
VSP2m - PLURIJET 80/130	VSP2 - PLURIJET 80/130			812								80	81	
-	VSP2 - PLURIJET 105/130			838								-	85	
VSP2m - PLURIJET 70/200	VSP2 - PLURIJET 70/200	2½"	1½"	855	375							83	83	
-	VSP2 - PLURIJET 95/200			881								-	87	

VSP2 - MK

FIELD AND PERFORMANCE DATA

50 Hz

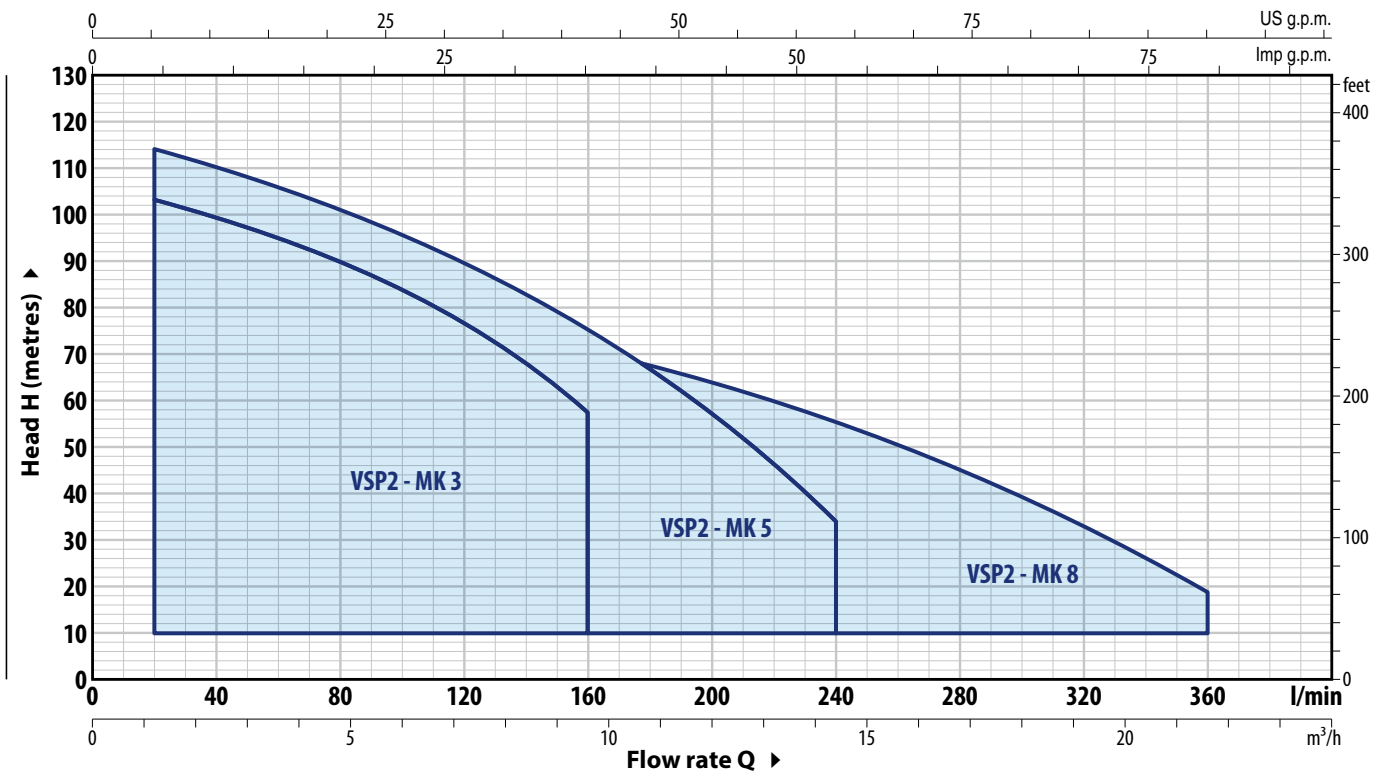

TYPE		POWER P ₂		Q m ³ /h l/min	H												
Single-phase	Three-phase	kW	HP		metres	0	1.2	2.4	4.8	7.2	9.6	12.0	14.4	16.8	19.2	21.6	
					0	20	40	80	120	160	200	240	280	320	360		
VSP2m - MK 3/3	VSP2 - MK 3/3	2x0.75	2x1	H metres	52.5	51.5	50	45	38.5	29							
VSP2m - MK 3/5	VSP2 - MK 3/5	2x1.1	2x1.5		87	85	83	75	64	48							
VSP2m - MK 3/6	VSP2 - MK 3/6	2x1.5	2x2		105	103	100	90	77	58							
VSP2m - MK 5/4	VSP2 - MK 5/4	2x0.75	2x1		57	-	54	50	45	37.5	28.5	17					
VSP2m - MK 5/5	VSP2 - MK 5/5	2x1.1	2x1.5		71	-	67.5	62.5	56	47	35.5	21.5					
VSP2m - MK 5/7	VSP2 - MK 5/7	2x1.5	2x2		99	-	95	88	78	66	50	30					
-	VSP2 - MK 5/8	2x2.2	2x3		114	-	108	100	90	75	57	34					
VSP2m - MK 8/4	VSP2 - MK 8/4	2x1.1	2x1.5		56	-	-	53.5	51	47.5	43	37.5	30.5	22.1	12		
VSP2m - MK 8/5	VSP2 - MK 8/5	2x1.5	2x2		70	-	-	67	64	59.5	54	47	38	27.5	15.5		
-	VSP2 - MK 8/6	2x2.2	2x3		84	-	-	80	77	72	64.5	56	45.5	33	18.5		

Q = Flow rate H = Total manometric head

Performance curves comply with EN ISO 9906 Grade 3B tolerance limits.

✘ The data shown in the diagram and table indicate performance with 2 pumps in operation

PERFORMANCE CURVES

50 Hz

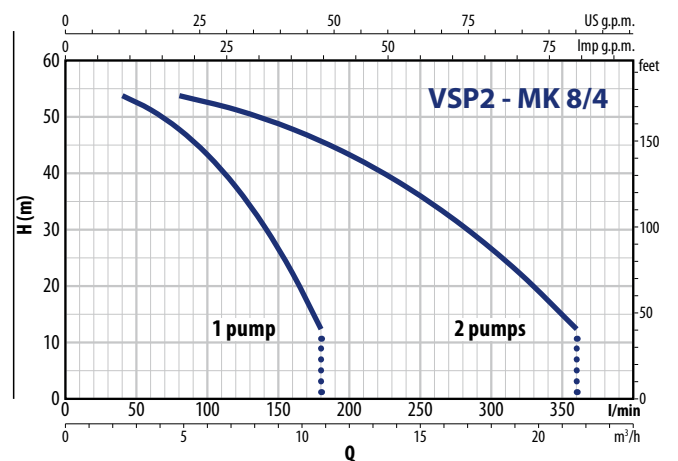
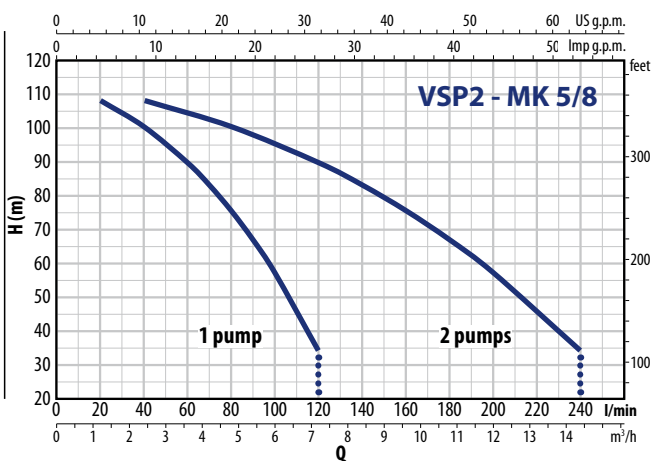
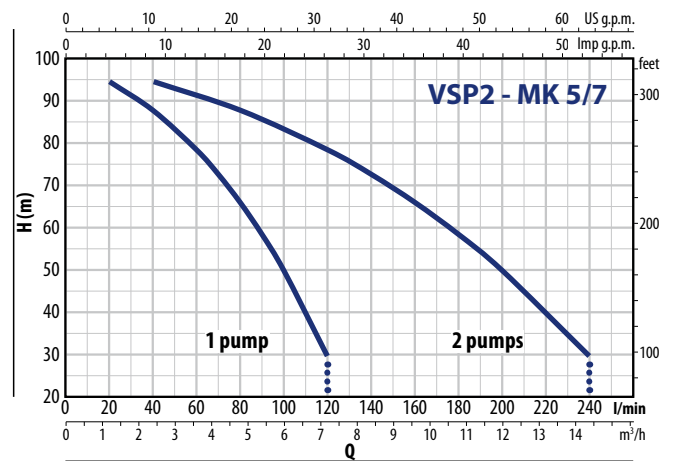
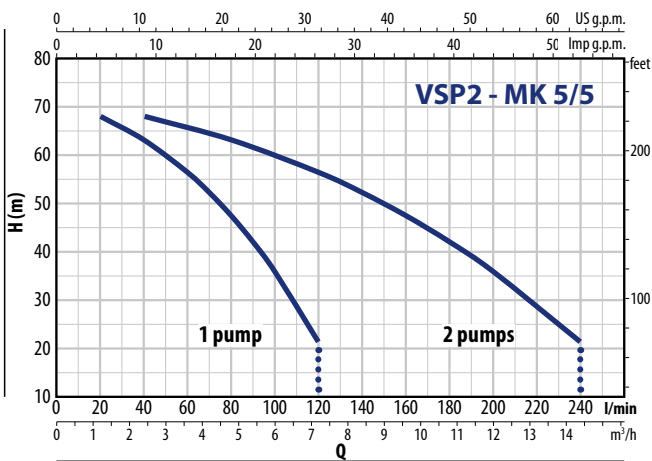
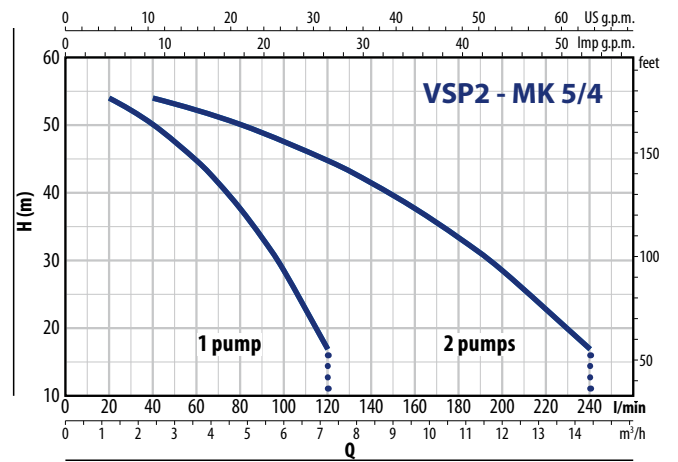
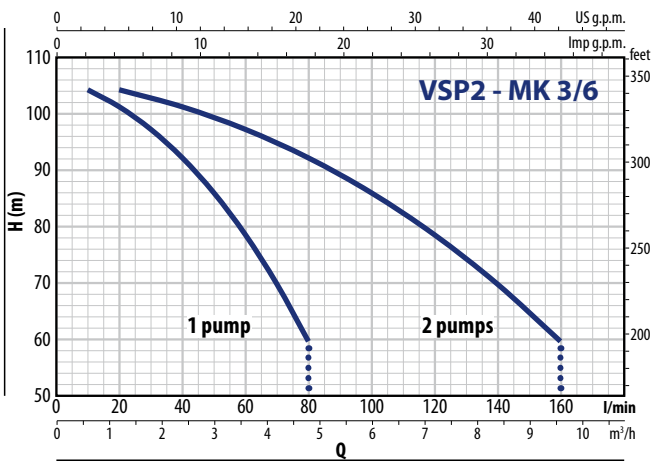
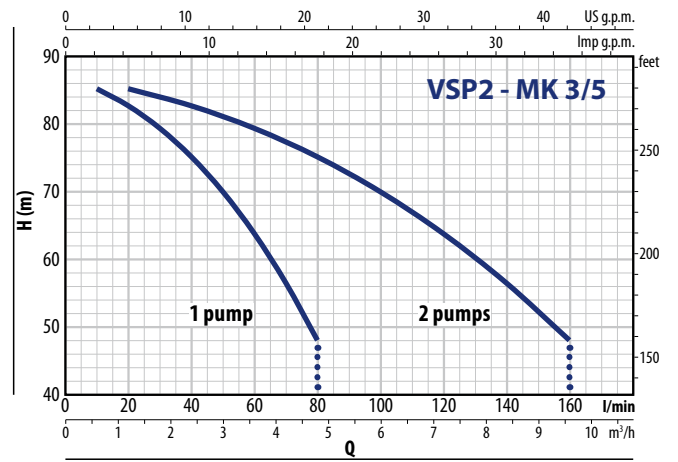
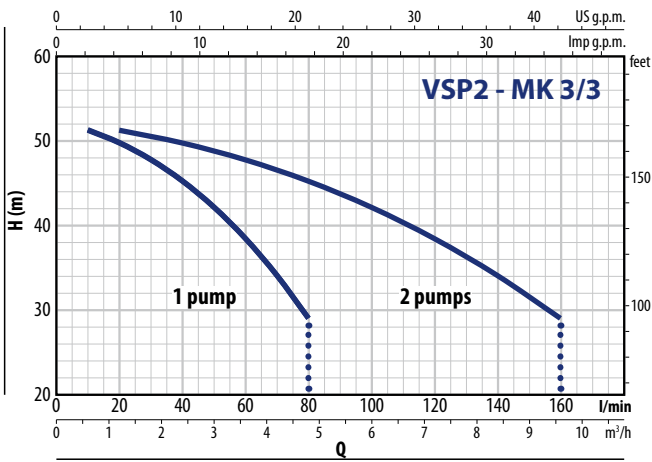

VSP2 - MK

PERFORMANCE CURVES

50 Hz

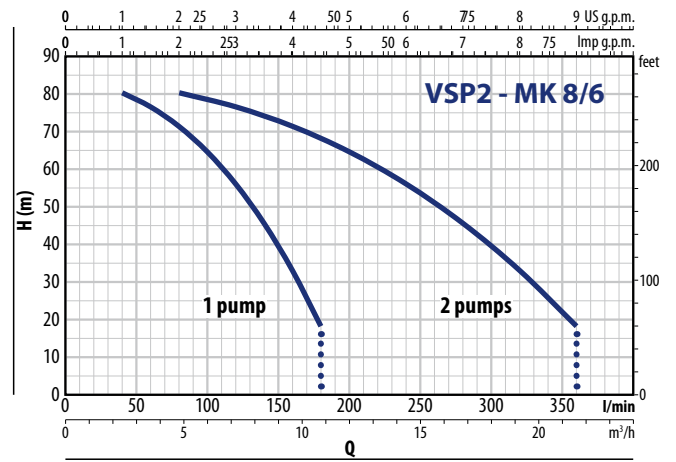
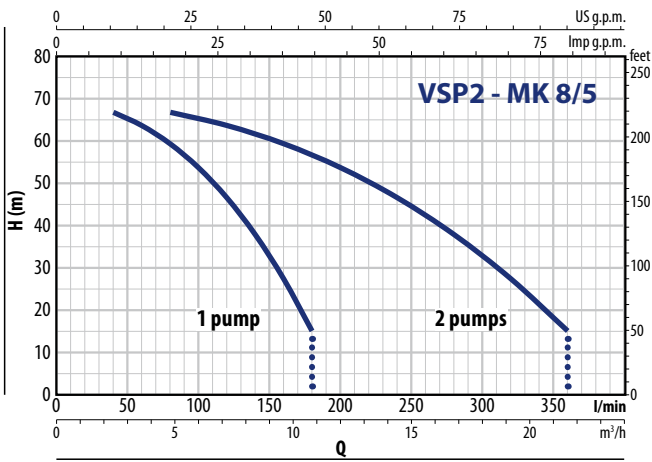

ABSORPTION

TYPE	VOLTAGE
Single-phase	230 V
VSP2m - MK 3/3	2 x 6.2 A
VSP2m - MK 3/5	2 x 7.8 A
VSP2m - MK 3/6	2 x 9.0 A
VSP2m - MK 5/4	2 x 6.4 A
VSP2m - MK 5/5	2 x 6.5 A
VSP2m - MK 5/7	2 x 9.0 A
VSP2m - MK 8/4	2 x 8.3 A
VSP2m - MK 8/5	2 x 10.0 A

TYPE	VOLTAGE
Three-phase	400 V
VSP2 - MK 3/3	2 x 1.7 A
VSP2 - MK 3/5	2 x 2.3 A
VSP2 - MK 3/6	2 x 2.8 A
VSP2 - MK 5/4	2 x 2.0 A
VSP2 - MK 5/5	2 x 2.2 A
VSP2 - MK 5/7	2 x 3.0 A
VSP2 - MK 5/8	2 x 3.5 A
VSP2 - MK 8/4	2 x 2.8 A
VSP2 - MK 8/5	2 x 3.4 A
VSP2 - MK 8/6	2 x 3.8 A

DIMENSIONS AND WEIGHT

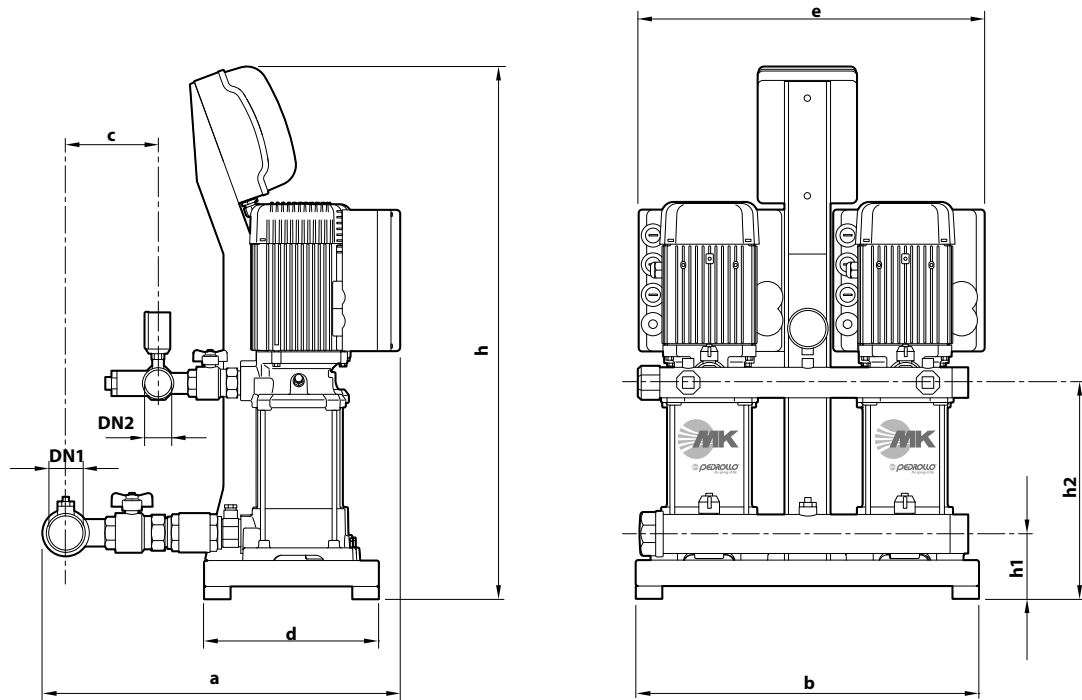

TYPE		PORTS		DIMENSIONS mm							kg		
Single-phase	Three-phase	DN1	DN2	a	b	c	d	e	h	h1	h2	1~	3~
VSP2m - MK 3/3	VSP2 - MK 3/3	2"	1½"	555	530	135	270	510	863	102	235	75	75
VSP2m - MK 3/5	VSP2 - MK 3/5										289	79	79
VSP2m - MK 3/6	VSP2 - MK 3/6										316	83	83
VSP2m - MK 5/4	VSP2 - MK 5/4										262	76	76
VSP2m - MK 5/5	VSP2 - MK 5/5										289	79	79
VSP2m - MK 5/7	VSP2 - MK 5/7										343	83	83
-	VSP2 - MK 5/8										370	-	84
VSP2m - MK 8/4	VSP2 - MK 8/4	2½"	1½"	600	171						316	82	82
VSP2m - MK 8/5	VSP2 - MK 8/5										262	83	83
-	VSP2 - MK 8/6										289	-	89

VSP2 - HT-PRO

FIELD AND PERFORMANCE DATA

50 Hz

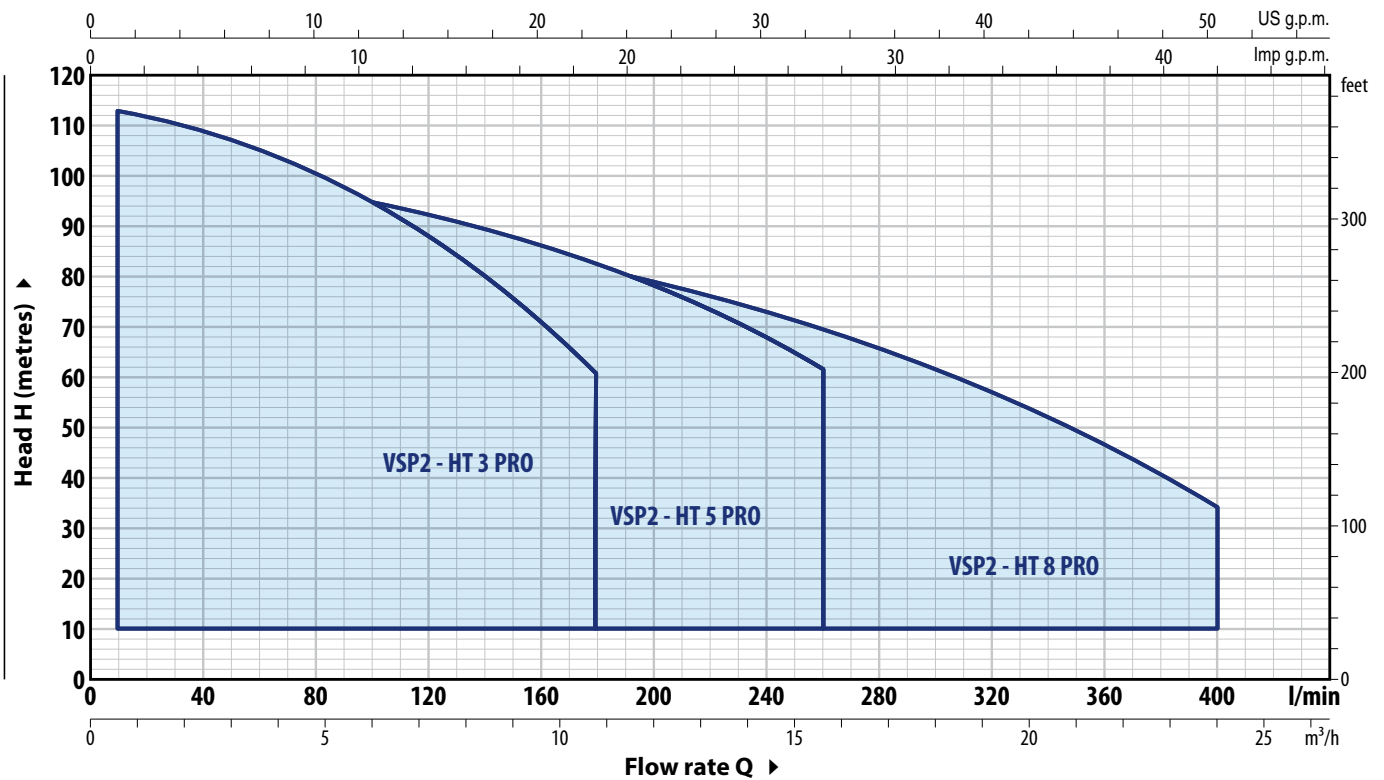

TYPE		POWER (P ₂)		Q	Flow rate								
Single-phase	Three-phase	kW	HP		m ³ /h	0	0.6	1.2	2.4	4.8	7.2	9.6	10.8
				l/min	0	10	20	40	80	120	160	180	
VSP2 - HTm 3/4 PRO	VSP2 - HT 3/4 PRO	2x0.75	2x1	H metres	65	65	63.5	62	57	50	40.5	35	
VSP2 - HTm 3/5 PRO	VSP2 - HT 3/5 PRO	2x1.1	2x1.5		81	80	79	77	71	62.5	51	44	
VSP2 - HTm 3/6 PRO	VSP2 - HT 3/6 PRO	2x1.5	2x2		97	96	95	93	86	75	61	52	
-	VSP2 - HT 3/7 PRO	2x1.8	2x2.5		113	112	111	108	100	88	71	61	

TYPE		POWER (P ₂)		Q	Flow rate										
Single-phase	Three-phase	kW	HP		m ³ /h	0	0.6	1.2	2.4	4.8	7.2	9.6	10.8	12	15.6
				l/min	0	10	20	40	80	120	160	180	200	260	
VSP2 - HTm 5/2 PRO	VSP2 - HT 5/2 PRO	2x0.75	2x1	H metres	35	35	32.7	32.3	32.5	31	25.5	27.5	26	16	
VSP2 - HTm 5/3 PRO	VSP2 - HT 5/3 PRO	2x1.1	2x1.5		51.5	52	51	50.5	49	46.5	43	41	39	31	
VSP2 - HTm 5/4 PRO	VSP2 - HT 5/4 PRO	2x1.5	2x2		68.5	68.5	68	67	65	62	57.5	55	52	41	
-	VSP2 - HT 5/5 PRO	2x1.8	2x2.5		86	85	85	84	81	77	72	68.5	65	51.5	
-	VSP2 - HT 5/6 PRO	2x2.2	2x3		103	103	102	101	98	93	86	82	78	62	

TYPE		POWER (P ₂)		Q	Flow rate													
Single-phase	Three-phase	kW	HP		m ³ /h	0	2.4	4.8	7.2	9.6	12	14.4	16.8	19.2	21.6	24		
				l/min	0	40	80	120	160	200	240	280	320	360	400			
VSP2 - HTm 8/3 PRO	VSP2 - HT 8/3 PRO	2x1.1	2x1.5	H metres	47	46.5	45.5	44	42	39.5	36.5	32.5	28	23.1	17			
VSP2 - HTm 8/4 PRO	VSP2 - HT 8/4 PRO	2x1.5	2x2		62.5	62	60.5	58.5	56	53	48.5	43.5	37.5	31	23			
-	VSP2 - HT 8/5 PRO	2x1.8	2x2.5		78	77.5	76	73	70	66	61	54.5	47	38.5	28.5			
-	VSP2 - HT 8/6 PRO	2x2.2	2x3		94	93	91	88	84	79	73	65.5	56.5	46	34.5			

Q = Flow rate H = Total manometric head

Performance curves comply with EN ISO 9906 Grade 3B tolerance limits.

✘ The data shown in the diagram and tables indicate performance with 2 pumps in operation

PERFORMANCE CURVES

50 Hz

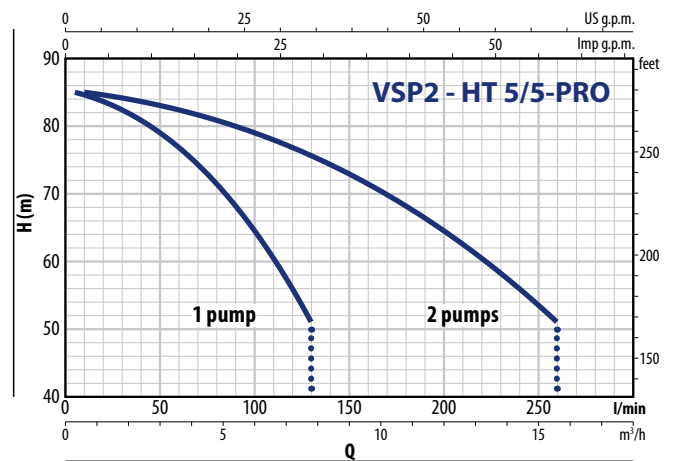
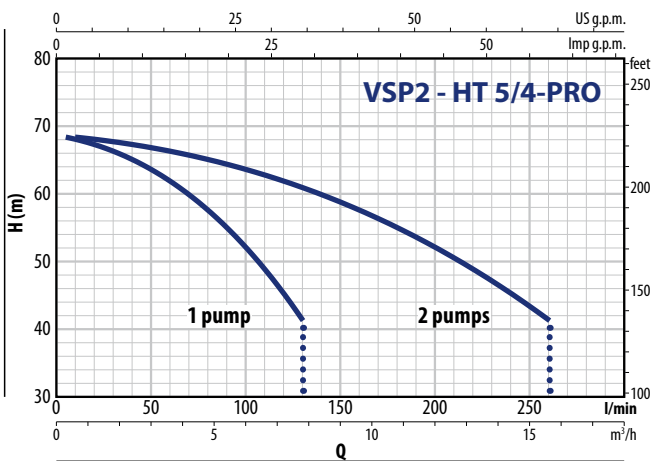
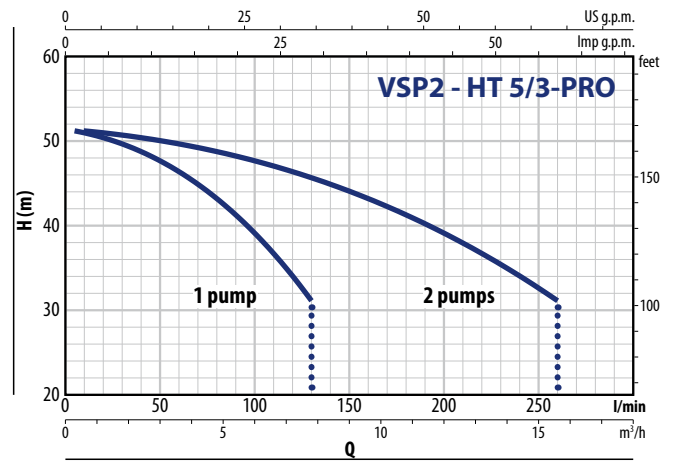
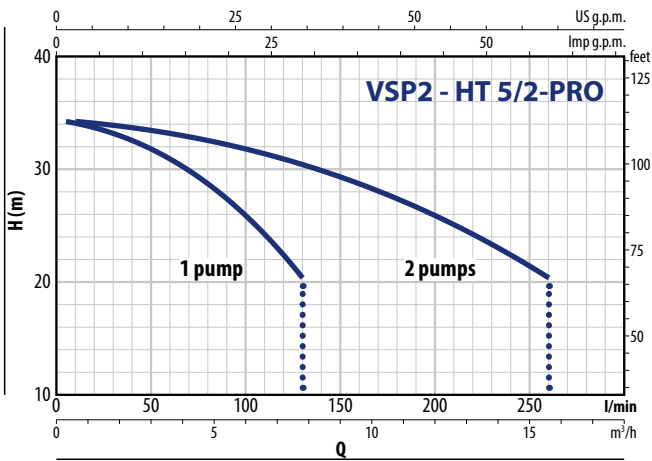
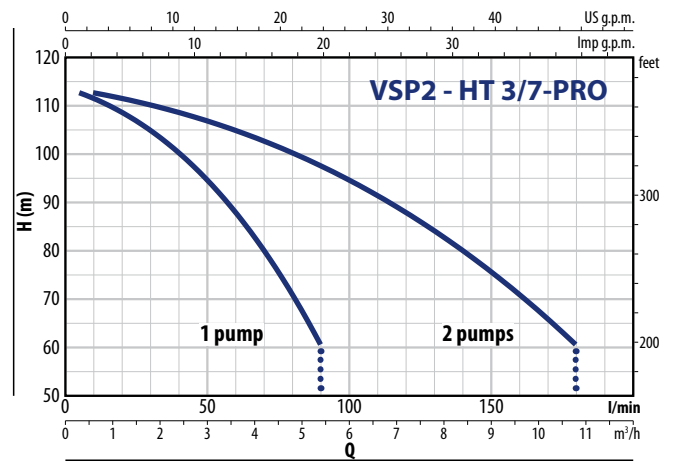
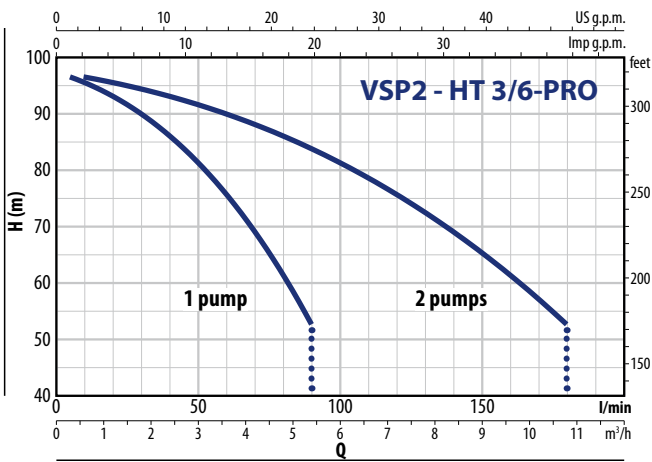
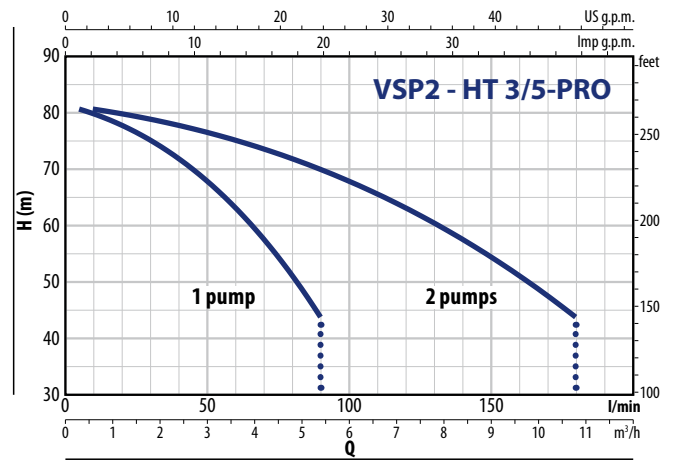
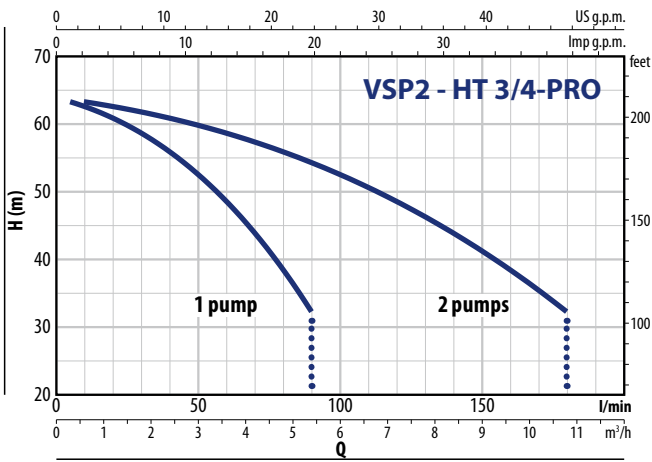

VSP2 - HT-PRO

PERFORMANCE CURVES

50 Hz

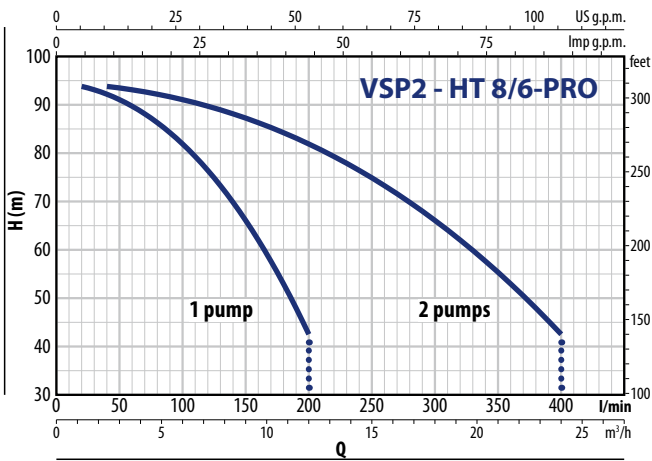
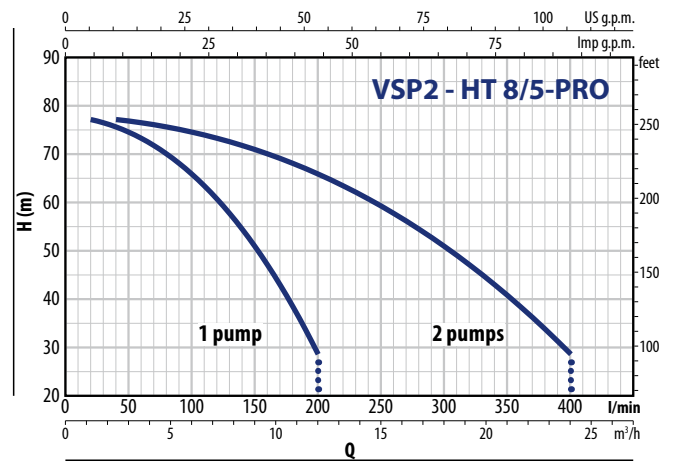
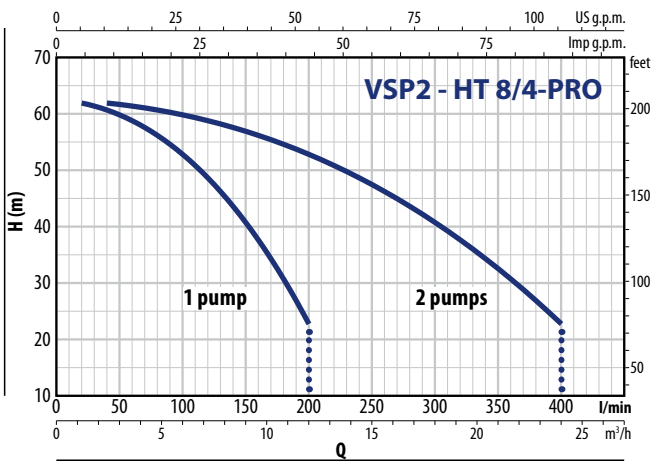
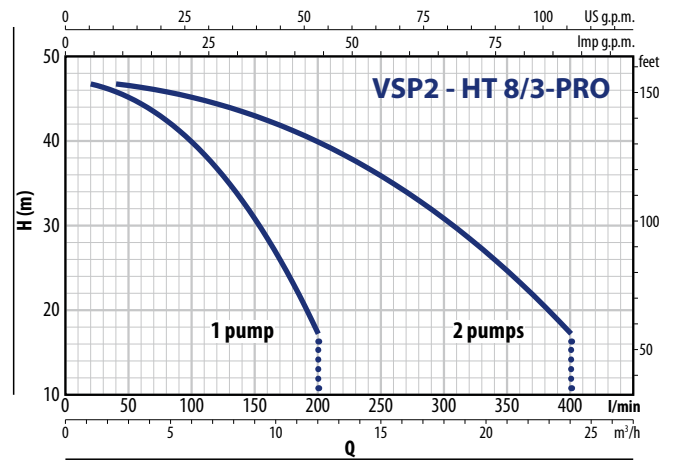
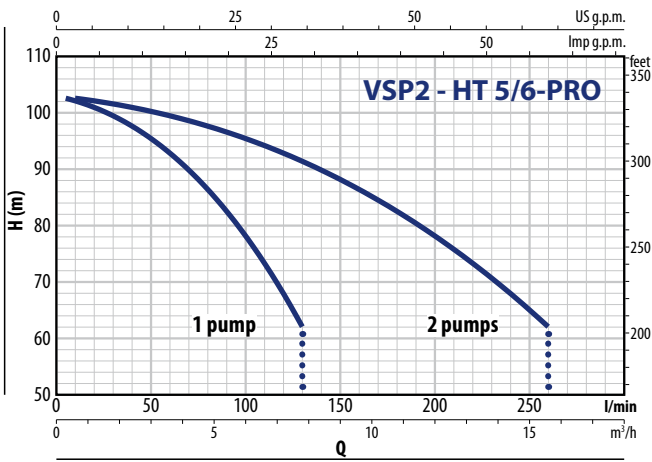

ABSORPTION

TYPE	VOLTAGE
Single-phase	230 V
VSP2m - HT 3/4 PRO	2 x 7.5 A
VSP2m - HT 3/5 PRO	2 x 9.0 A
VSP2m - HT 3/6 PRO	2 x 10.5 A
VSP2m - HT 5/2 PRO	2 x 7.0 A
VSP2m - HT 5/3 PRO	2 x 8.0 A
VSP2m - HT 5/4 PRO	2 x 9.5 A
VSP2m - HT 8/3 PRO	2 x 8.5 A
VSP2m - HT 8/4 PRO	2 x 10.0 A

TYPE	VOLTAGE
Three-phase	400 V
VSP2 - HT 3/4 PRO	2 x 2.5 A
VSP2 - HT 3/5 PRO	2 x 3.0 A
VSP2 - HT 3/6 PRO	2 x 3.5 A
VSP2 - HT 3/7 PRO	2 x 4.2 A
VSP2 - HT 5/2 PRO	2 x 2.3 A
VSP2 - HT 5/3 PRO	2 x 2.4 A
VSP2 - HT 5/4 PRO	2 x 3.2 A
VSP2 - HT 5/5 PRO	2 x 4.0 A
VSP2 - HT 5/6 PRO	2 x 4.3 A
VSP2 - HT 8/3 PRO	2 x 3.0 A
VSP2 - HT 8/4 PRO	2 x 3.4 A
VSP2 - HT 8/5 PRO	2 x 4.0 A
VSP2 - HT 8/6 PRO	2 x 4.5 A

DIMENSIONS AND WEIGHT

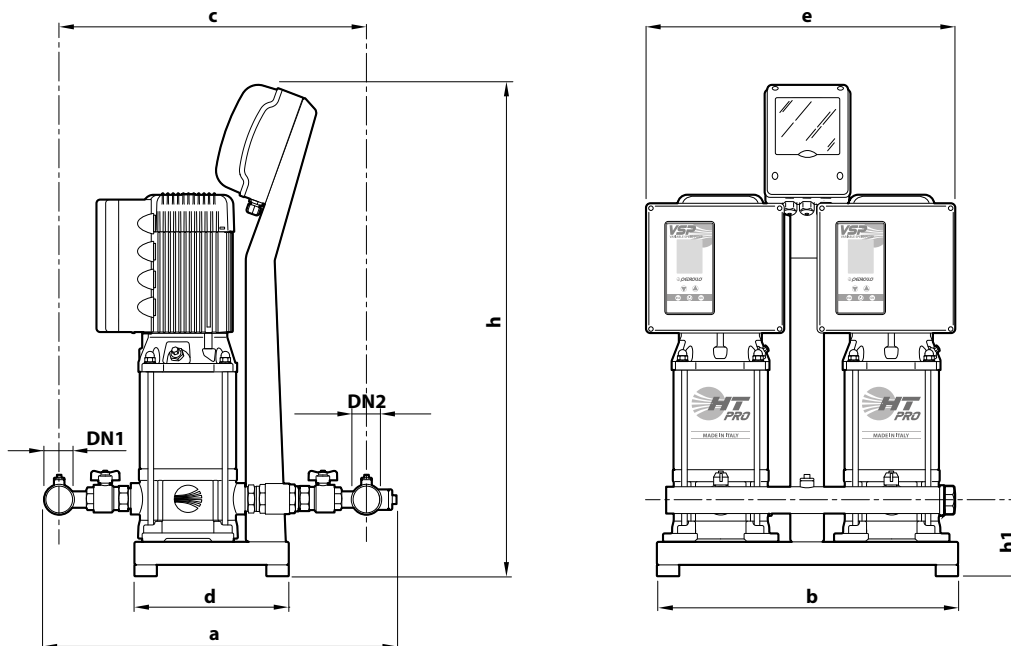

TYPE		PORTS		DIMENSIONS mm							kg	
Single-phase	Three-phase	DN1	DN2	a	b	c	d	e	h	h1	1~	3~
VSP2m-HT 3/4 PRO	VSP2-HT 3/4 PRO	2"	2"	694	530	576	270	542	863	135	97	97
VSP2m-HT 3/5 PRO	VSP2-HT 3/5 PRO										97	97
VSP2m-HT 3/6 PRO	VSP2-HT 3/6 PRO										100	100
-	VSP2-HT 3/7 PRO										-	110
VSP2m-HT 5/2 PRO	VSP2-HT 5/2 PRO	2"	2"	740	530	622	270	542	863	135	96	96
VSP2m-HT 5/3 PRO	VSP2-HT 5/3 PRO										96	96
VSP2m-HT 5/4 PRO	VSP2-HT 5/4 PRO										100	100
-	VSP2-HT 5/5 PRO										-	105
-	VSP2-HT 5/6 PRO	-	107	-	-	-	-	-	-	-	-	-
VSP2m-HT 8/3 PRO	VSP2-HT 8/3 PRO	2½"	2½"	833	530	698	270	542	863	140	101	101
VSP2m-HT 8/4 PRO	VSP2-HT 8/4 PRO										105	105
-	VSP2-HT 8/5 PRO										-	112
-	VSP2-HT 8/6 PRO										-	114

-  Clean water
-  Domestic use
-  Civil use



INSTALLATION AND USE

GPW is a pre-assembled system designed to connect to water mains or a primary collection tanks. It provides water supply and pressurization and is ideal for residential, commercial, and public buildings. It's also suitable for hotels, park irrigation, as well as industrial water handling and treatment.

GPW is compatible with clean water and aqueous solutions that do not chemically or mechanically harm the materials used and are free from abrasive or fibrous substances.

PRODUCT DESCRIPTION

GPW is a variable speed pressurization system **comprising two or three pumps** assembled into one unit. It is electronically controlled by two or three **STEADYPRES** devices connected in parallel. These devices automatically adjust the pump operation based on the system's varying water demands, ensuring constant pressure.

When water withdrawal reduces the system pressure, the first pump activates to meet the required flow rate, maintaining pressure at the set value. As the maximum rotation speed is reached, additional pumps start up in sequence to fulfill the system's water demand.

COMPONENTS

- ※ **Pumps** connected in parallel via suction and discharge manifolds. Each pump is equipped with a ball valve on the suction side and a ball valve and non-return valve (integrated in STEADYPRES) on the discharge side.
- ※ **BASE** made of metal profile and equipped with adjustable vibration-damping feet.
- ※ **STEADYPRES ELECTRONIC DEVICES** installed directly on the delivery pipe of each individual pump. They continuously regulate the rotation speed, ensuring a constant pressure even as user demands fluctuate. Each inverter can manage the alternating operation of pumps as needed.

GPW is designed to protect the system from:

- ※ Dry running
- ※ overvoltage and undervoltage
- ※ **ELECTRICAL PANEL** equipped with magnetothermal motor protection circuit breakers for three-phase versions, and magnetothermal circuit breakers for single-phase versions.



GP2W – 5CR

Pressurization units comprising two multistage centrifugal pumps equipped with STEADYPRES inverters capable of maintaining a constant pressure in the system. The GP2W - 5CR are suitable for domestic and residential water supply, garden irrigation, and general clean water handling.

TECHNICAL DATA

- Liquid temperature up to **+40 °C**
- Ambient temperature between **0 °C** and **+40 °C**
- Max. pressure in the pump body **7 bar**
- Continuous running duty **S1**



GP2W – MK

Pressurization units comprising three vertical multistage pumps equipped with STEADYPRES inverters, capable of maintaining constant pressure in the system. GP3W - MK are suitable for residential, commercial, and public water supply, large-scale irrigation, and handling clean water in general.

TECHNICAL DATA

- Liquid temperature up to **+40 °C**
- Ambient temperature between **0 °C** and **+40 °C**
- Max. pressure in pump body **10 bar**
- Continuous running duty **S1**



GP3W – MK

Pressurization units comprising three vertical multistage pumps equipped with STEADYPRES inverters capable of maintaining constant pressure in the system. GP3W - MK are suitable for residential, commercial, and public water supply, large-scale irrigation, and handling clean water in general.

TECHNICAL DATA

- Liquid temperature up to **+40 °C**
- Ambient temperature between **0 °C** and **+40 °C**
- Max. pressure in pump body **10 bar**
- Continuous running duty **S1**

GP2W - 5CR

FIELD AND PERFORMANCE DATA

50 Hz

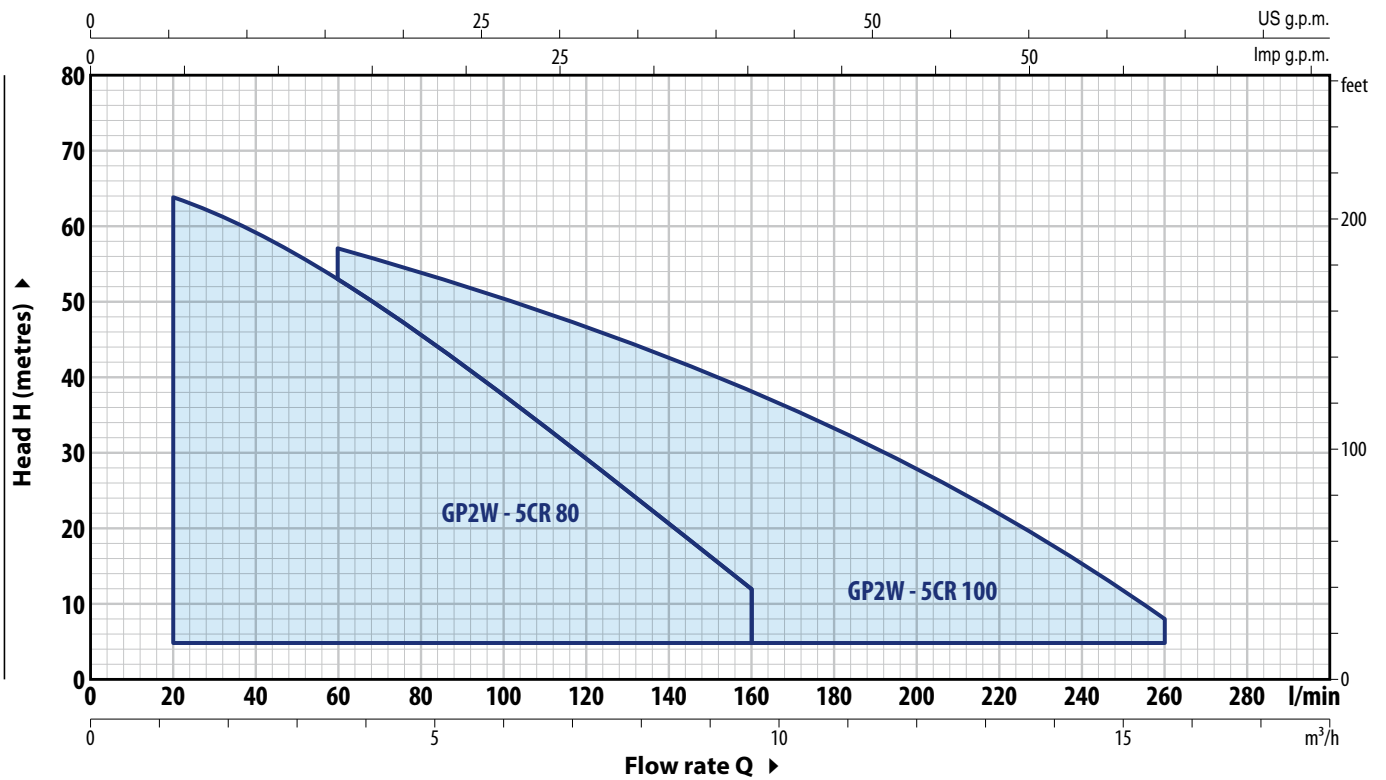

TYPE		POWER P ₂		Q	Flow rate														
Single-phase	Three-phase	kW	HP		m ³ /h	0	1.2	2.4	3.6	4.8	6.0	7.2	8.4	9.6	10.8	12.0	13.2	14.4	15.6
GP2Wm - 5CR 80	GP2W - 5CR 80	2x0.75	2x1	l/min	0	20	40	60	80	100	120	140	160	180	200	220	240	260	
GP2Wm - 5CR 100	GP2W - 5CR 100	2x0.9	2x1.25	H metres	67	64	59	53	45.5	37.5	29.5	20.5	12						
					63	61.5	59.5	57	53.5	50.5	46.5	42.5	38	33	28	22	15	8	

Q = Flow rate H = Total manometric head

✘ The data shown in the diagram and tables indicate performance with 2 pumps in operation

PERFORMANCE CURVES

50 Hz

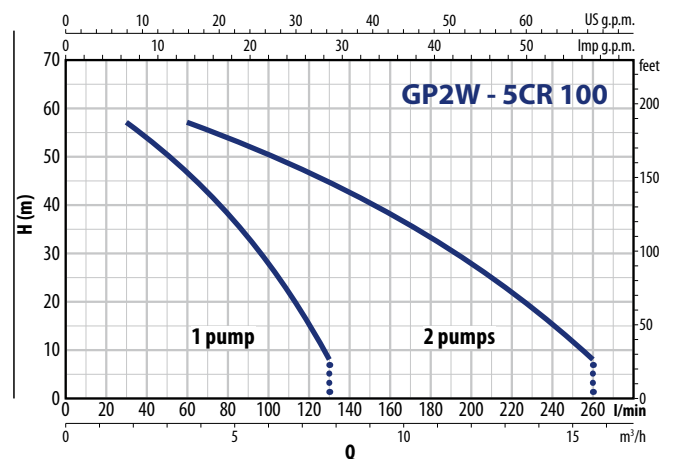
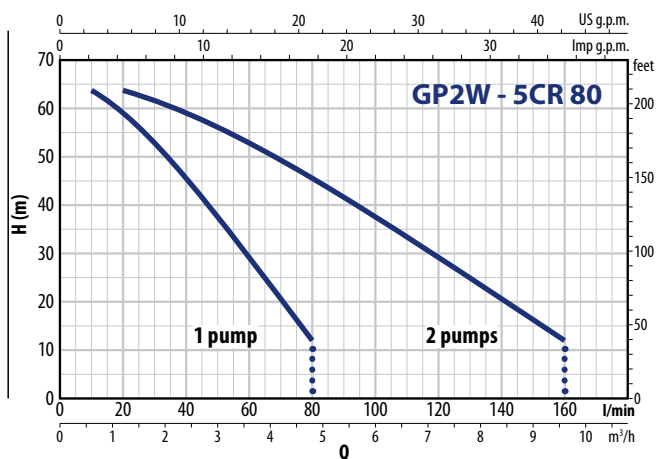

ABSORPTION

TYPE	VOLTAGE
Single-phase	230 V
GP2Wm - 5CR 80	2 x 9.0 A
GP2Wm - 5CR 100	2 x 10.0 A

TYPE	VOLTAGE
Three-phase	400 V
GP2W - 5CR 80	2 x 3.2 A
GP2W - 5CR 100	2 x 3.2 A

DIMENSIONS AND WEIGHT

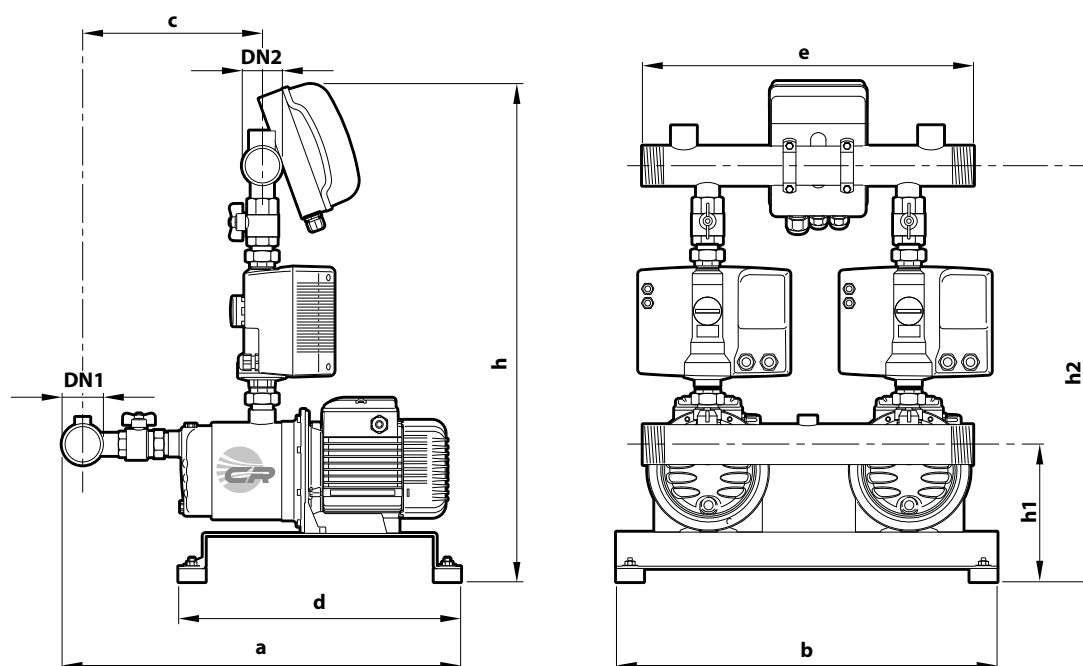

Monofase	TIPO	Trifase	BOCCHIE		DIMENSIONS mm										kg	
			DN1	DN2	a	b	c	d	e	h		h1	h2		1~	3~
GP2Wm - 5CR 80	GP2W - 5CR 80	1½"	1½"	608	570	273	420	500	754	712	205	624	582	64	67	
GP2Wm - 5CR 100	GP2W - 5CR 100	2"		687		347								65	68	

GP2W - MK

FIELD AND PERFORMANCE DATA

50 Hz

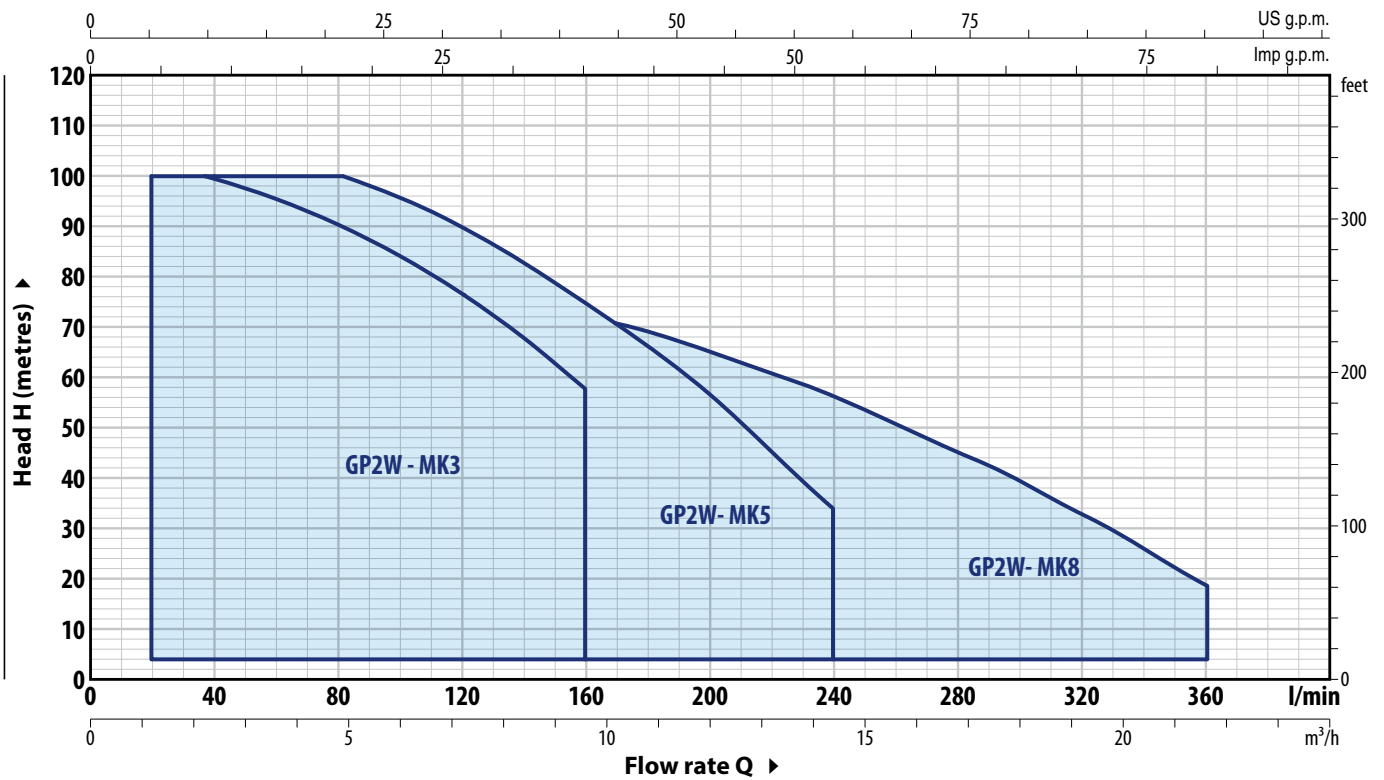

TYPE		POWER P ₂		Q	H metres												
Single-phase	Three-phase	kW	HP		m ³ /h	0	1.2	2.4	4.8	7.2	9.6	12.0	14.7	16.8	19.2	21.6	
				l/min	0	20	40	80	120	160	200	240	280	320	360		
GP2Wm - MK 3/3	GP2W - MK 3/3	2x0.75	2x1		52.5	51.5	50	45	38.5	29							
GP2Wm - MK 3/5	GP2W - MK 3/5	2x1.1	2x1.5		87	85	83	75	64	48							
GP2Wm - MK 3/6	GP2W - MK 3/6	2x1.5	2x2		100	100	100	90	77	58							
GP2Wm - MK 5/4	GP2W - MK 5/4	2x0.75	2x1		57	-	54	50	45	37.5	28.5	17					
GP2Wm - MK 5/5	GP2W - MK 5/5	2x1.1	2x1.5		71	-	67.5	62.5	56	47	35.5	21.5					
GP2Wm - MK 5/7	GP2W - MK 5/7	2x1.5	2x2		99	-	95	88	78	66	50	30					
GP2Wm - MK 5/8	GP2W - MK 5/8	2x2.2	2x3		100	-	100	100	90	75	57	34					
GP2Wm - MK 8/4	GP2W - MK 8/4	2x1.1	2x1.5		56	-	-	53.5	51	47.5	43	37.5	30.5	22	12		
GP2Wm - MK 8/5	GP2W - MK 8/5	2x1.5	2x2		70	-	-	67	64	59.5	54	47	38	27.5	15.5		
GP2Wm - MK 8/6	GP2W - MK 8/6	2x2.2	2x3		84	-	-	80	77	72	64.5	56	45.5	33	18.5		

Q = Flow rate H = Total manometric head

✘ The data shown in the diagram and tables indicate performance with 2 pumps in operation

PERFORMANCE CURVES

50 Hz

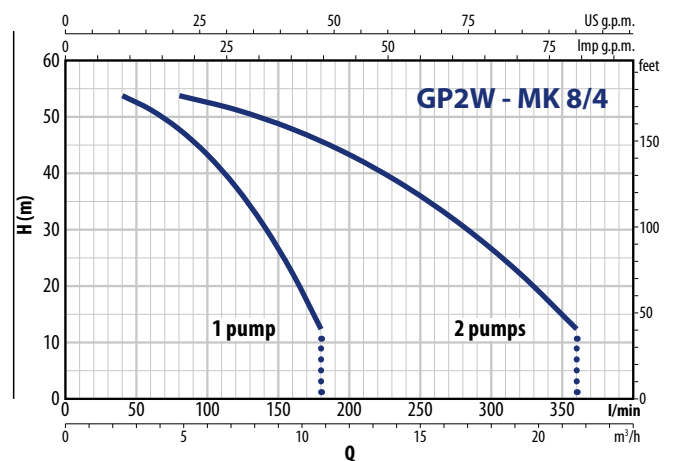
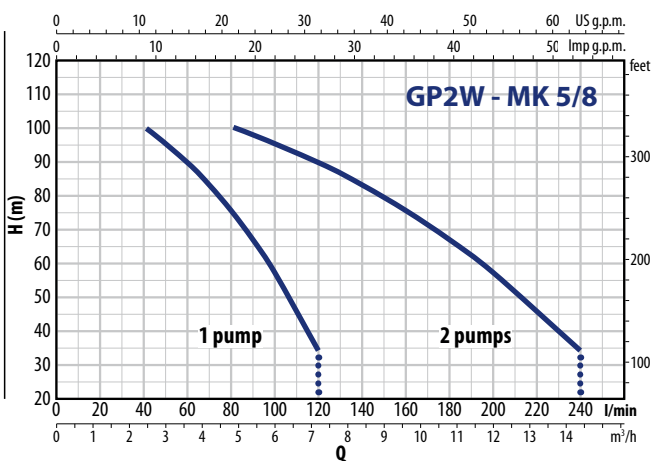
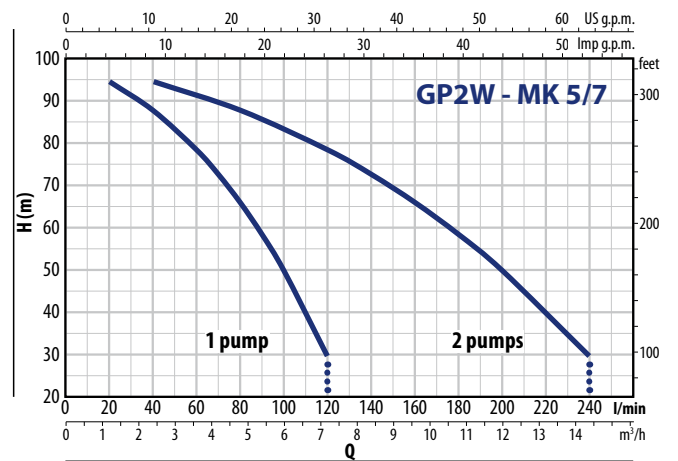
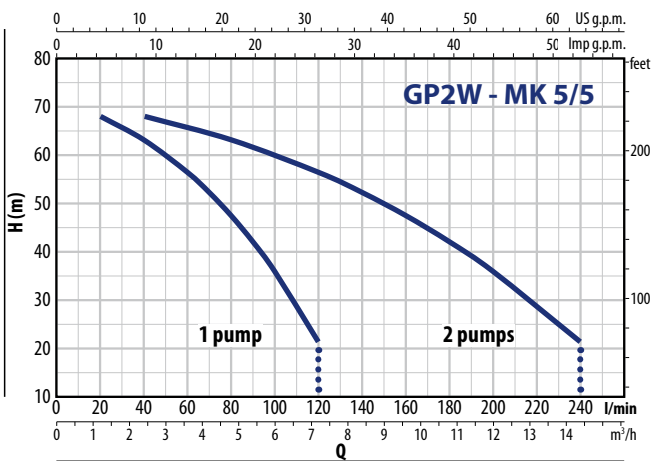
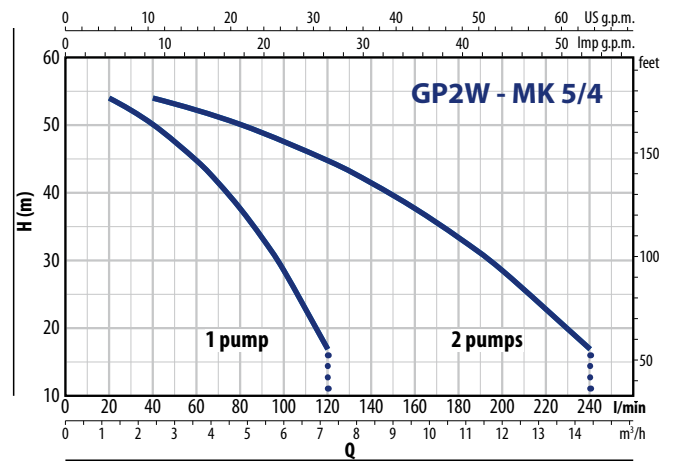
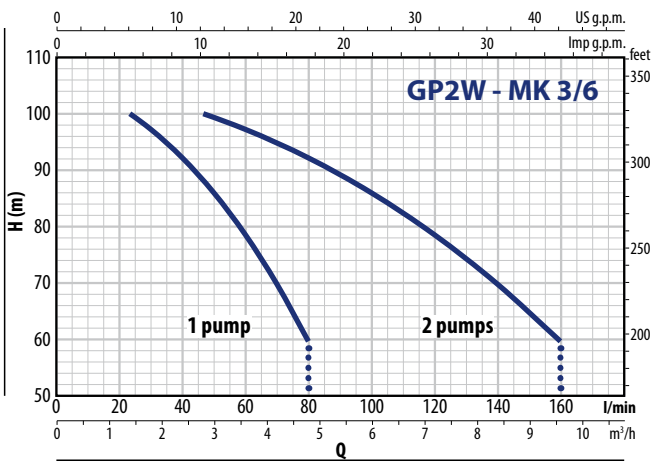
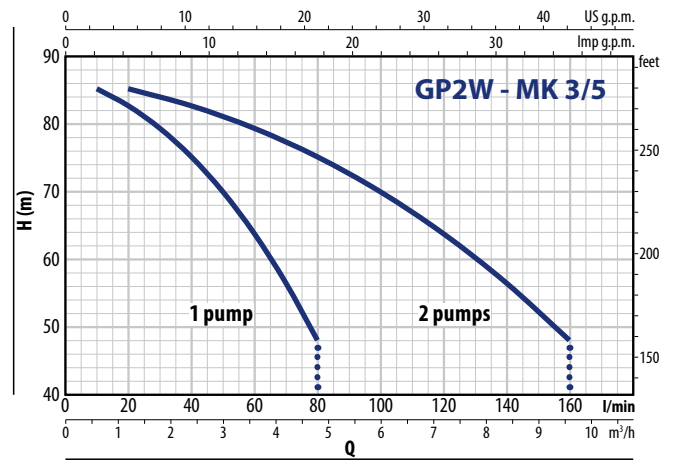
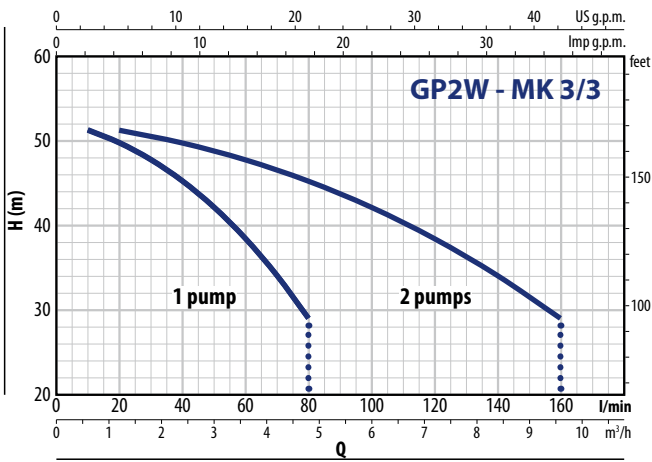

GP2W - MK

PERFORMANCE CURVES

50 Hz

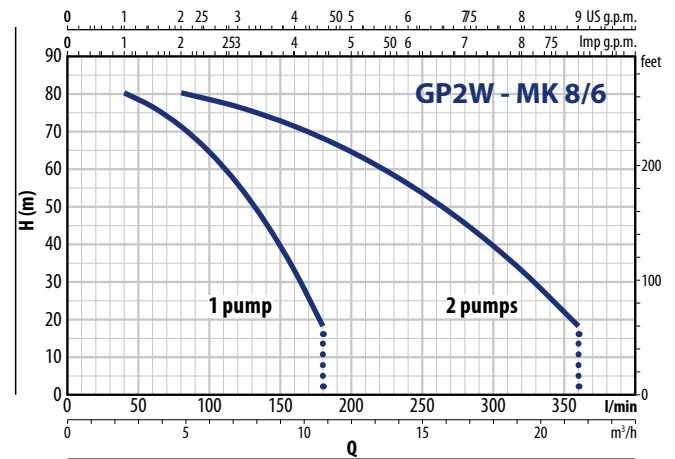
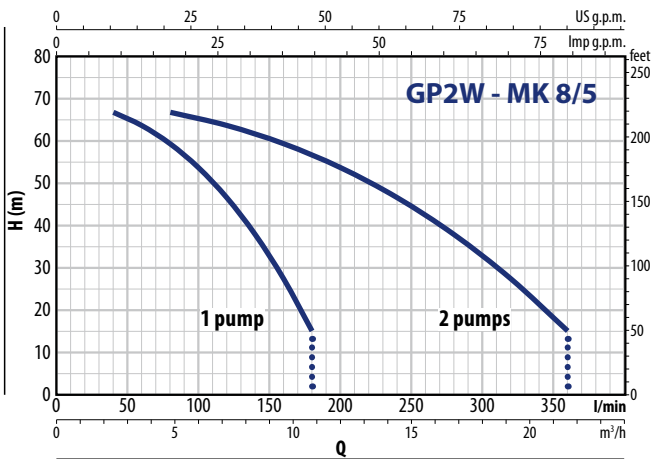

ABSORPTION

TYPE	VOLTAGE
Single-phase	230 V
GP2Wm - MK 3/3	2 x 9.0 A
GP2Wm - MK 3/5	2 x 12.5 A
GP2Wm - MK 3/6	2 x 14.0 A
GP2Wm - MK 5/4	2 x 9.0 A
GP2Wm - MK 5/5	2 x 11.0 A
GP2Wm - MK 5/7	2 x 13.5 A
GP2Wm - MK 5/8	2 x 16.0 A
GP2Wm - MK 8/4	2 x 12.5 A
GP2Wm - MK 8/5	2 x 14.0 A
GP2Wm - MK 8/6	2 x 18.0 A

TYPE	VOLTAGE
Three-phase	400 V
GP2W - MK 3/3	2 x 3.3 A
GP2W - MK 3/5	2 x 4.2 A
GP2W - MK 3/6	2 x 5.0 A
GP2W - MK 5/4	2 x 3.3 A
GP2W - MK 5/5	2 x 4.0 A
GP2W - MK 5/7	2 x 5.0 A
GP2W - MK 5/8	2 x 6.0 A
GP2W - MK 8/4	2 x 4.2 A
GP2W - MK 8/5	2 x 5.0 A
GP2W - MK 8/6	2 x 6.5 A

DIMENSIONS AND WEIGHT

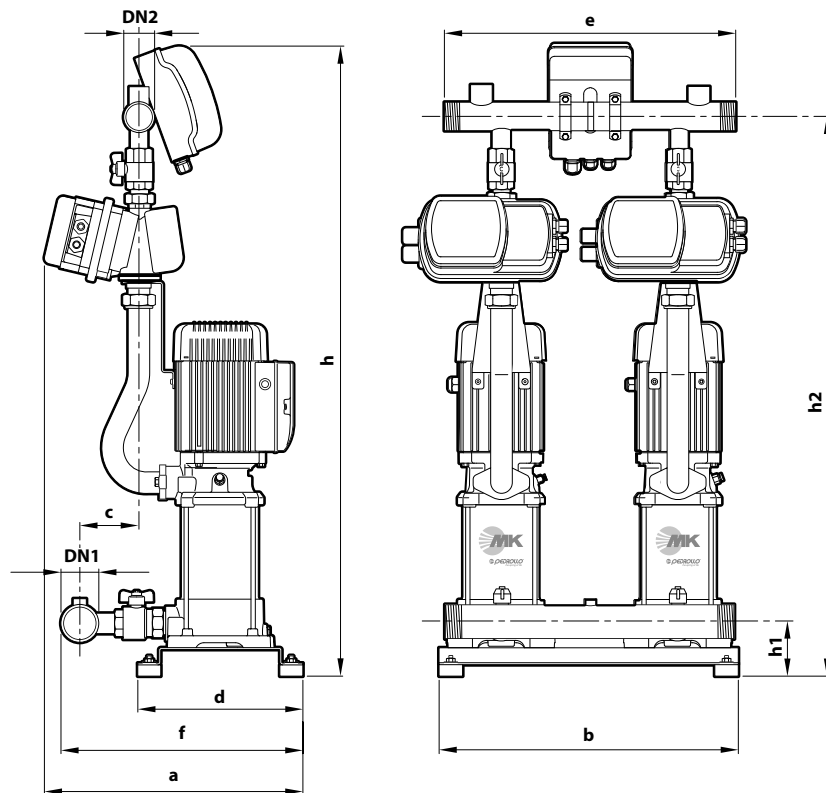

TYPE		PORTS		DIMENSIONS mm									kg	
Single-phase	Three-phase	DN1	DN2	a	b	c	d	e	f	h	h1	h2	1~	3~
GP2Wm - MK 3/3	GP2W - MK 3/3	2"	1½"	447	510	107	284	500	420	965	91	842	80.0	79.0
GP2Wm - MK 3/5	GP2W - MK 3/5									1019		896	84.0	84.0
GP2Wm - MK 3/6	GP2W - MK 3/6									1046		923	88.0	87.0
GP2Wm - MK 5/4	GP2W - MK 5/4									992		869	80.0	80.0
GP2Wm - MK 5/5	GP2W - MK 5/5									1019		896	83.0	83.0
GP2Wm - MK 5/7	GP2W - MK 5/7									1073		950	88.0	88.0
GP2Wm - MK 5/8	GP2W - MK 5/8									1100		977	89.0	88.0
GP2Wm - MK 8/4	GP2W - MK 8/4	2½"	2"						435	992	91	869	86.0	86.0
GP2Wm - MK 8/5	GP2W - MK 8/5									1019		896	87.0	86.0
GP2Wm - MK 8/6	GP2W - MK 8/6									1046		923	93.0	92.0

GP3W – MK

FIELD AND PERFORMANCE DATA

50 Hz

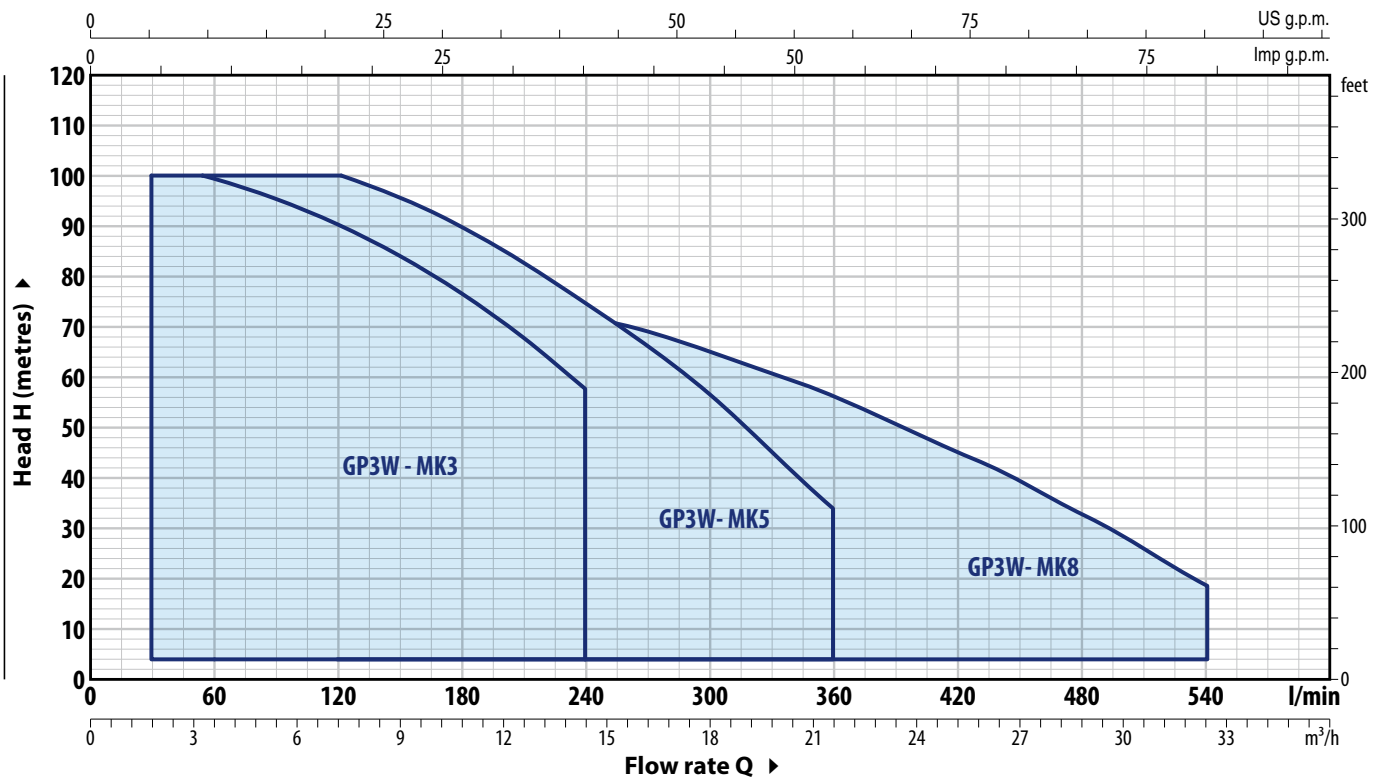

TYPE		POWER P ₂		Q	H metres											
Single-phase	Three-phase	kW	HP		m ³ /h	0	1.8	3.6	7.2	10.8	14.5	18.1	21.7	25.3	28.9	32.5
				l/min	0	30	60	120	180	240	300	360	420	480	540	
GP3Wm - MK 3/3	GP3W - MK 3/3	3x0.75	3x1	H metres	52.5	51.5	50	45	38.5	29						
GP3Wm - MK 3/5	GP3W - MK 3/5	3x1.1	3x1.5		87	85	83	75	64	48						
GP3Wm - MK 3/6	GP3W - MK 3/6	3x1.5	3x2		100	100	100	90	77	58						
GP3Wm - MK 5/4	GP3W - MK 5/4	3x0.75	3x1		57	-	54	50	45	37.5	28.5	17				
GP3Wm - MK 5/5	GP3W - MK 5/5	3x1.1	3x1.5		71	-	67.5	62.5	56	47	35.5	21.5				
GP3Wm - MK 5/7	GP3W - MK 5/7	3x1.5	3x2		99	-	95	88	78	66	50	30				
GP3Wm - MK 5/8	GP3W - MK 5/8	3x2.2	3x3		100	-	100	100	90	75	57	34				
GP3Wm - MK 8/4	GP3W - MK 8/4	3x1.1	3x2		56	-	-	53.5	51	47.5	43	37.5	30.5	22.1	12	
GP3Wm - MK 8/5	GP3W - MK 8/5	3x1.5	3x2.5		70	-	-	67	64	59.5	54	47	38	27.5	15.5	
GP3Wm - MK 8/6	GP3W - MK 8/6	3x2.2	3x3		84	-	-	80	77	72	64.5	56	45.5	33	18.5	

Q = Flow rate H = Total manometric head

✘ The data shown in the diagram and tables indicate performance with 3 pumps in operation

PERFORMANCE CURVES

50 Hz

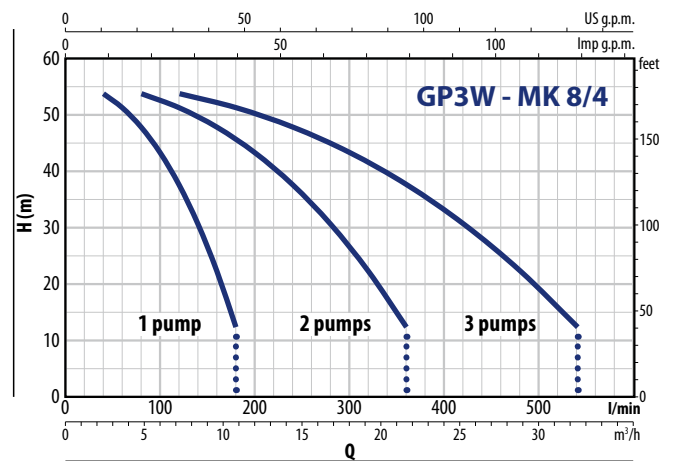
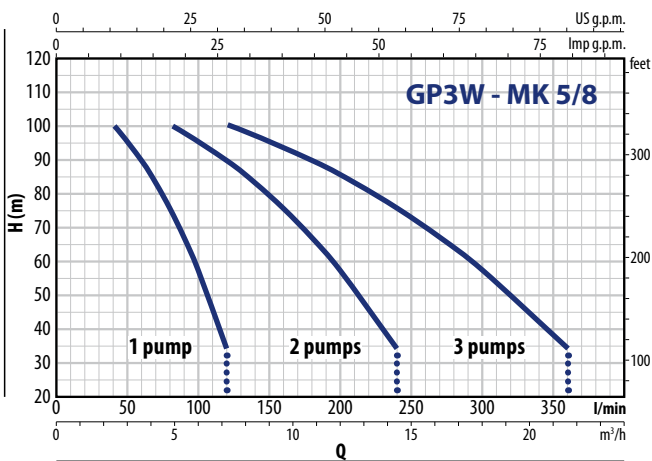
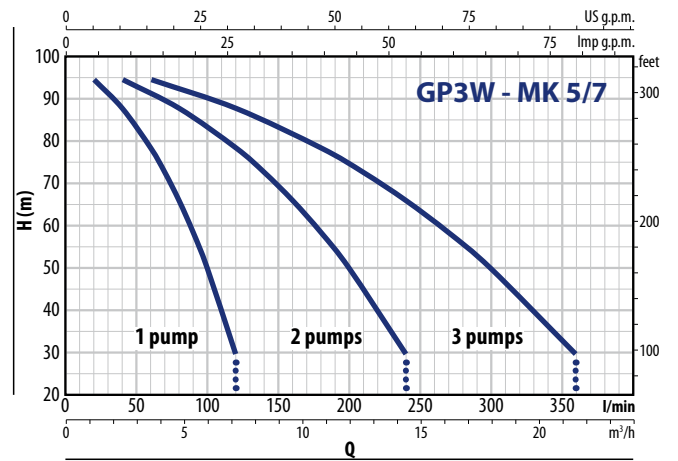
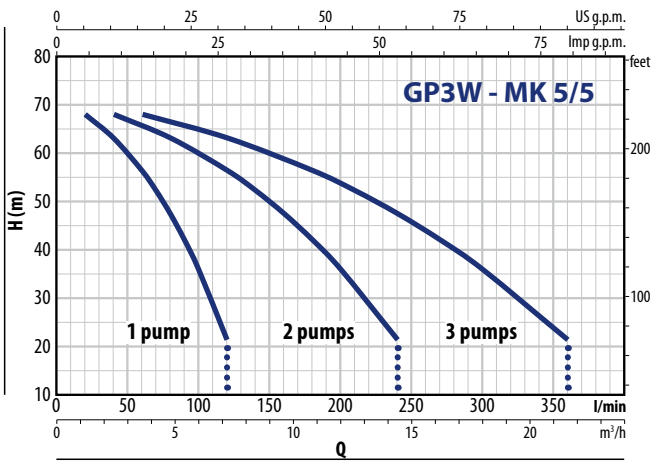
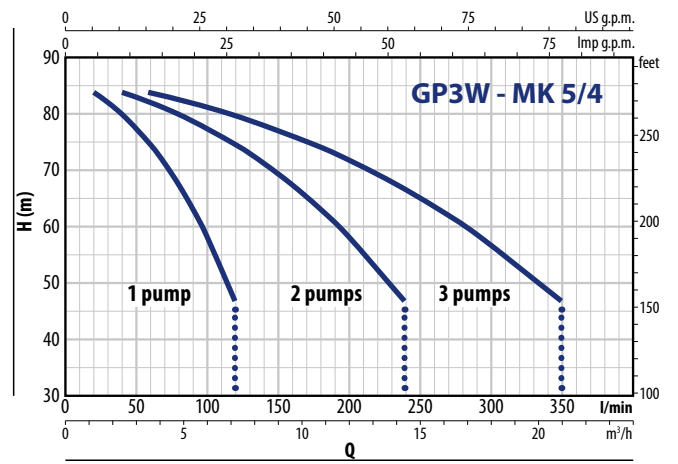
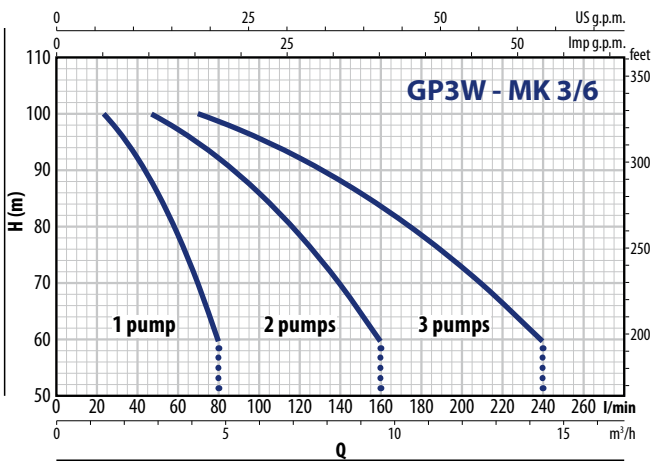
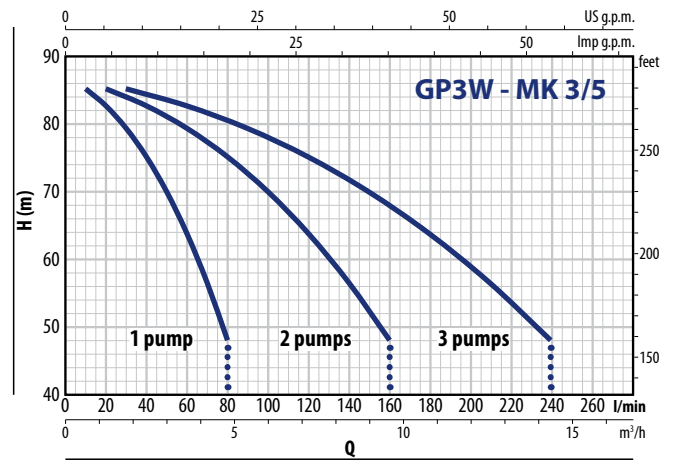
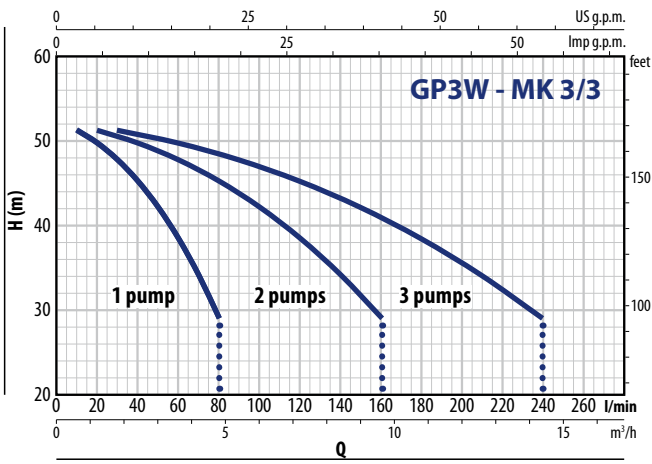

GP3W - MK

PERFORMANCE CURVES

50 Hz

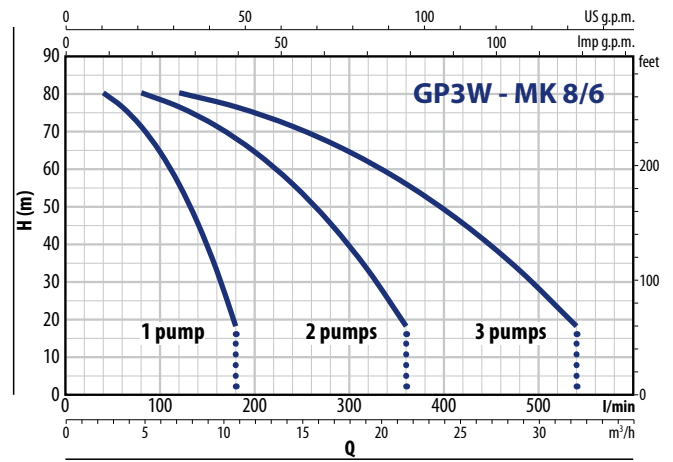
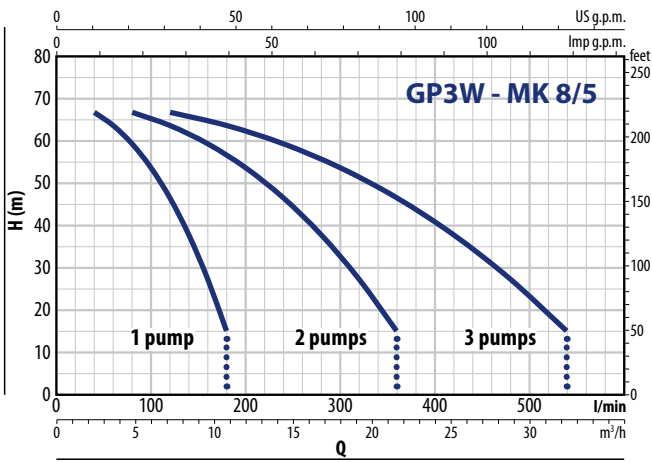

ABSORPTION

TYPE	VOLTAGE
Single-phase	230 V
GP3Wm - MK 3/3	3 x 9.0 A
GP3Wm - MK 3/5	3 x 12.5 A
GP3Wm - MK 3/6	3 x 14.0 A
GP3Wm - MK 5/4	3 x 9.0 A
GP3Wm - MK 5/5	3 x 11.0 A
GP3Wm - MK 5/7	3 x 13.5 A
GP3Wm - MK 5/8	3 x 16.0 A
GP3Wm - MK 8/4	3 x 12.5 A
GP3Wm - MK 8/5	3 x 14.0 A
GP3Wm - MK 8/6	3 x 18.0 A

TYPE	VOLTAGE
Three-phase	400 V
GP3W - MK 3/3	3 x 3.3 A
GP3W - MK 3/5	3 x 4.2 A
GP3W - MK 3/6	3 x 5.0 A
GP3W - MK 5/4	3 x 3.3 A
GP3W - MK 5/5	3 x 4.0 A
GP3W - MK 5/7	3 x 5.0 A
GP3W - MK 5/8	3 x 6.0 A
GP3W - MK 8/4	3 x 4.2 A
GP3W - MK 8/5	3 x 5.0 A
GP3W - MK 8/6	3 x 6.5 A

DIMENSIONS AND WEIGHT

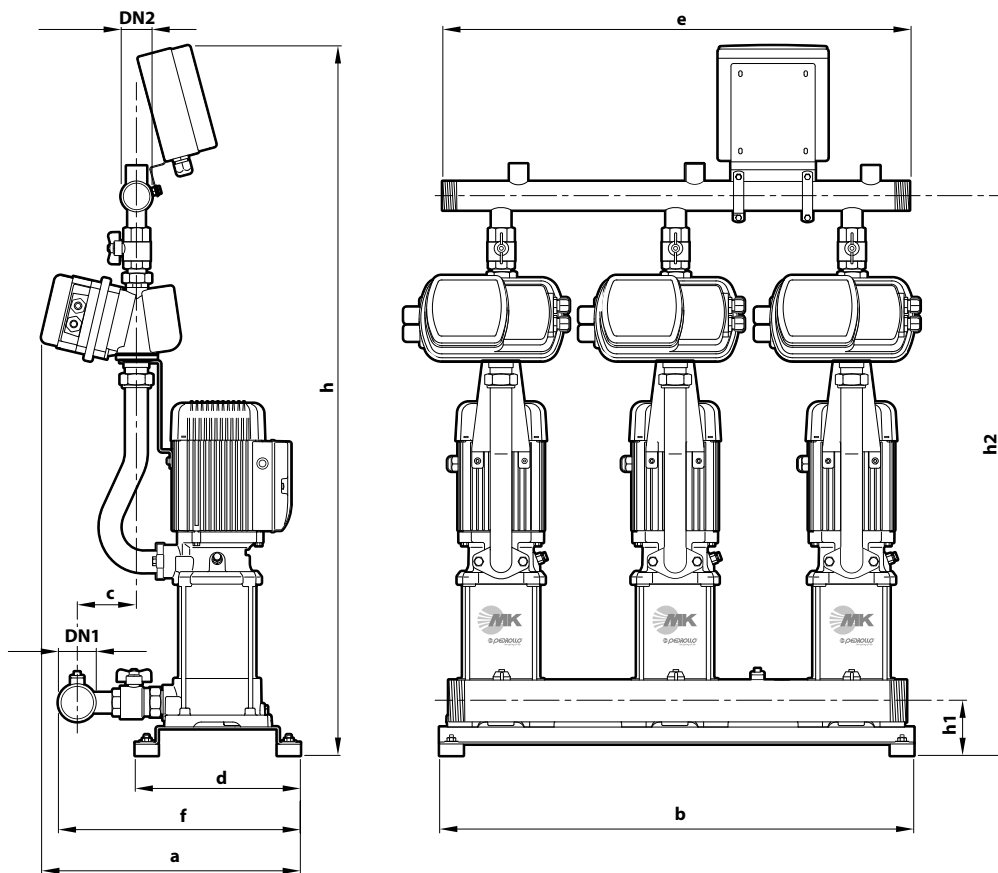

TYPE		PORTS		DIMENSIONS mm								kg		
Single-phase	Three-phase	DN1	DN2	a	b	c	d	e	f	h	h1	h2	1~	3~
GP3Wm - MK 3/3	GP3W - MK 3/3	2½"	2"	447	810	115	284	800	435	1143	91	849	123.0	124.0
GP3Wm - MK 3/5	GP3W - MK 3/5									1197		876	130.0	130.0
GP3Wm - MK 3/6	GP3W - MK 3/6									1224		930	135.0	136.0
GP3Wm - MK 5/4	GP3W - MK 5/4									1170		876	124.0	125.0
GP3Wm - MK 5/5	GP3W - MK 5/5									1197		903	129.0	130.0
GP3Wm - MK 5/7	GP3W - MK 5/7									1251		957	136.0	136.0
GP3Wm - MK 5/8	GP3W - MK 5/8									1278		984	140.0	140.0
GP3Wm - MK 8/4	GP3W - MK 8/4									1170		876	131.0	132.0
GP3Wm - MK 8/5	GP3W - MK 8/5									1197		903	132.0	133.0
GP3Wm - MK 8/6	GP3W - MK 8/6									1224		930	142.0	142.0



PERFORMANCE RANGE

- Flow rate up to **3.5 m³/h** (0.97 l/s)
- Head up to **6 m**

INSTALLATION AND USE

Energy-efficient, class A electronic circulators significantly reduce electricity use by up to 85% compared to traditional models with similar performance, making them an ideal choice for home and residential heating systems. These circulators feature advanced control electronics that allow for customizable functionality to meet the specific needs of various systems. Users can easily adjust and select the desired operating program directly from the electrical panel's controller, enhancing system efficiency and comfort by minimizing energy consumption and reducing water flow noise in pipes, valves, and radiators. For optimal performance, installation should be in well-ventilated, enclosed spaces or areas protected from the elements.

APPLICATION LIMITS

- Liquid temperature between **+2 °C** and **+95 °C**
- Ambient temperature between **0 °C** and **+40 °C**
- Maximum working pressure = **6 bar**.
- Minimum suction pressure:
 - **0.3 bar** to 50 °C
 - **1.0 bar** to 95 °C
- Maximum relative humidity **≤ 95%**.
- Sound pressure level **< 43 db(A)**
- Glycol maximum **30%**
- Continuous running duty **S1**

COMPONENTS

1 Pump body	Cast iron with cathaphoresis treatment
2 Impeller	Technopolymer
3 Shaft	Ceramic
4 Bearings	Graphite
5 end thrust, thrust	Ceramic
6 Motor	<ul style="list-style-type: none"> – Motor 230 V (-10%; +6%) - 50 Hz – Power consumption P1: min 3 W - max 42 W – Absorbed current I1: Min 0.03 A - Max 0.33 A – Insulation: class H – Protection rating: IP 44 – Appliance class: II
7 Gaskets	EPDM
8 Circuit board	

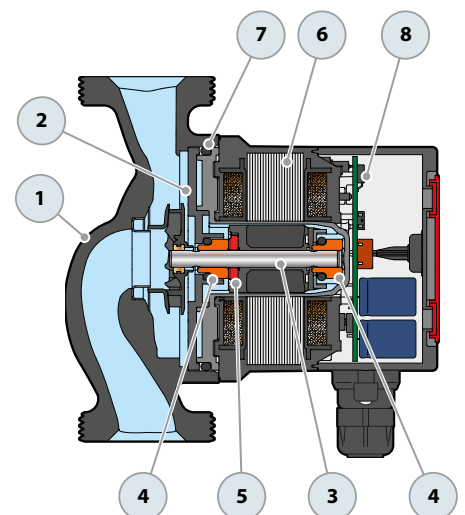

OPERATING MODE

The electrical panel enables users to select the optimal working curve for the circulator through three distinct programs. A bright LED indicator displays the circulator's operating status, with variations in illumination providing clear, at-a-glance information.



PROPORTIONAL PROGRAM



This setting proportionally adjusts the pressure (head) based on the system's heat demand and desired flow rate



CONSTANT PROGRAM



This setting maintains a constant pressure level (head) according on the system's heat demand and desired flow rate.



CUSTOMISED PROGRAM



Allows the pump's speed to be set to a constant level, adjustable through a selector that can be positioned between the MIN and MAX settings to fine-tune performance.

An LED indicator on the electrical panel alerts users to the potential presence of air in the system. Should this occur, the circulator's on-board electronics automatically engage a motor unlocking feature to resolve the issue.



WHITE LED

Presence of air in the system. Bleed the system



RED LED

The circulator is in a locked state but is still under power

DIMENSIONS AND WEIGHT

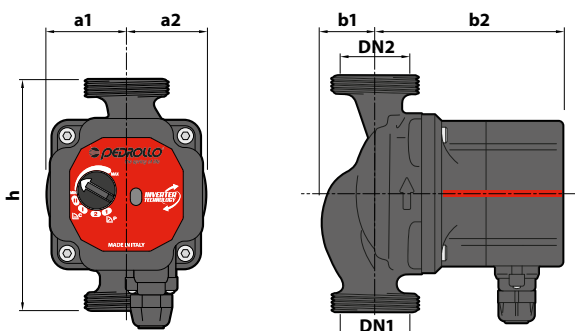

TYPE	PORTS		DIMENSIONS mm					kg
	DN1	DN2	h	a1	a2	b1	b2	
Single-phase								
DHL 25-60/130	G 1½	G 1½	130	45	45	29	104.2	2.01
DHL 25-60/180			180					

PERFORMANCE CURVES

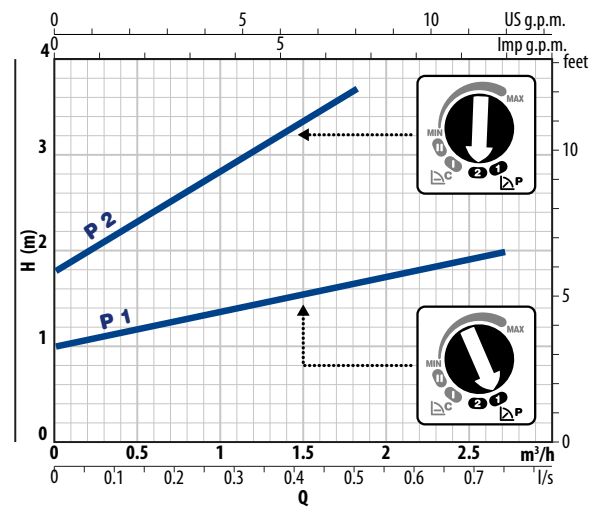

PERFORMANCE CURVES

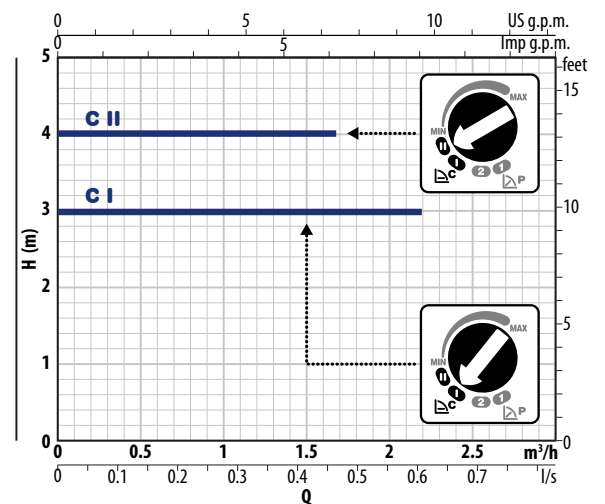

PERFORMANCE CURVES MIN-MAX

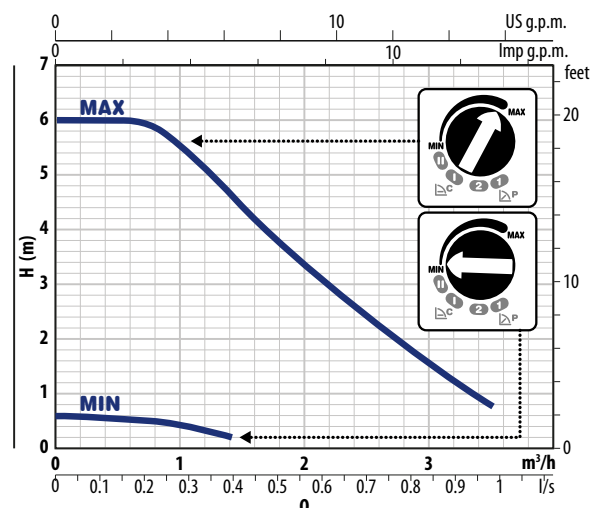



INSTALLATION AND USE

The **E1/E2** switchboards are **multifunctional electronic switchboards** designed to manage one or two pumps in residential, commercial, or industrial settings.

Thanks to their versatility, they provide protection and facilitate operations such as pressurization, filling, drainage, and emptying, accommodating both clean and wastewater applications.

PRODUCT DESCRIPTION

The **E1/E2** electronic control panels offer unmatched adaptability for various systems by featuring **six selectable operating modes**. These modes facilitate comprehensive pump management and protection through both analogue and digital inputs, alongside electrical parameter monitoring.

Equipped with an intuitive **keypad and LCD display**, the panels simplify programming and configuration of pump settings, protections, and operational modes through a user-friendly guided process.

These panels feature **dry-running protection**, managed through power factor (**cosφ**), current control, or by activating a float or level probe. The integrated self-learning Wizard simplifies the system initialization by automatically storing key electrical parameter values, ensuring a quick and straightforward setup.

When managing two pumps, the **E2** panel automatically switches between them, reducing wear and maximizing efficiency in their operation.

MAIN FEATURES

- ✧ Power supply:
 - 1~ 230V±15% (E1/E2 MONO)**
 - 3~ 400V±15% (E1/E2 TRI)**
- ✧ Frequency: **50/60 Hz**
- ✧ door lock main isolating switch,
- ✧ Motor and auxiliary circuit protection fuse
- ✧ **ABS** outer container
- ✧ **IP55** protection degree
- ✧ Ambient temperature: **-5 °C ÷ +40 °C**
- ✧ Relative humidity **50% at 40 °C**

INPUTS

The **E1/E2** electrical panels allow pumps to be managed via analogue and digital inputs:

- ✧ Pressure switches
- ✧ Floats
- ✧ Remote contacts
- ✧ Run/stop floats
- ✧ Level probes
- ✧ Pressure transducers

CONTROLS

- ✧ Minimum and maximum operating current control
- ✧ Minimum and maximum supply voltage control
- ✧ Input phase failure or inversion control

E1 Electronic electrical panel for an pump

TYPE	VOLTAGE	CURRENT POWER (*)	FUSES PROTECTION
E1 MONO	1~ 230 V - 50/60 Hz	up to 18 A	20 A
E1 TRI/1	3~ 400 V - 50/60 Hz	up to 18 A	20 A
E1 TRI/2	3~ 400 V - 50/60 Hz	up to 25 A	32 A

(*) The rated current value refers to a single electric pump

E2 Electronic electrical panel for two pumps

TYPE	VOLTAGE	CURRENT POWER (*)	FUSES COVER
E2 MONO	1~ 230V - 50/60 Hz	up to 18 A	20 A
E2 TRI	3~ 400V - 50/60 Hz	up to 16 A	32 A

OPERATING MODE

METHOD 1: DRAINING AND PRESSURIZING

Dry run protection via cosq or current

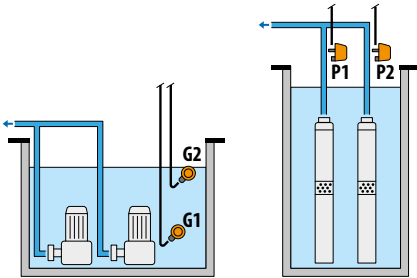

METHOD 2: DRAINING AND PRESSURIZING

Dry run protection via level probes

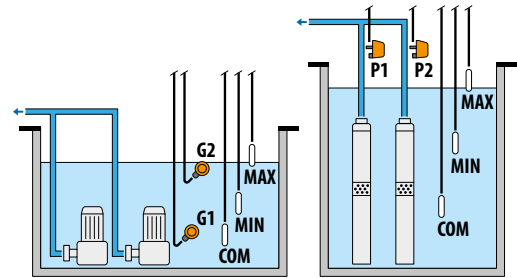

METHOD 3: DRAINING

Dry run protection via minimum float switch

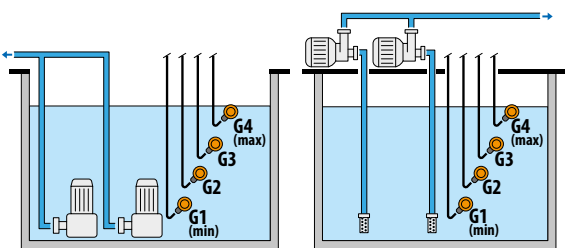

METHOD 4: FILLING

Dry run protection via minimum float switch

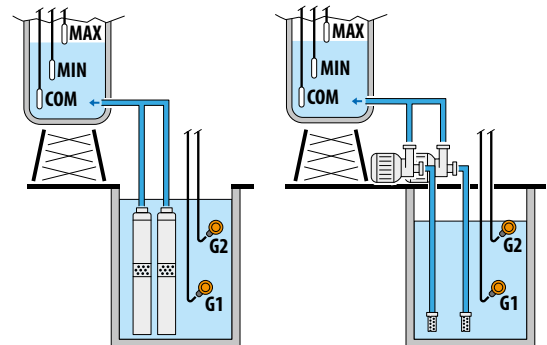

METHOD 5: PRESSURIZING

Dry run protection via cosq or current

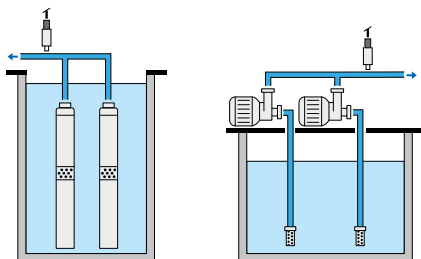

METHOD 6: CUSTOMIZED:

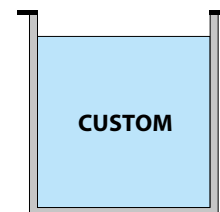

DIMENSIONS AND HOLE SPACING FOR MOUNTING

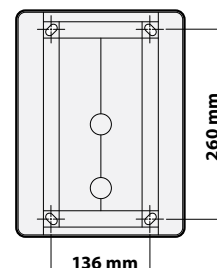
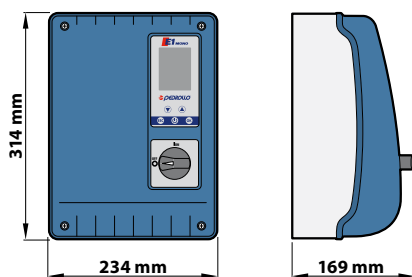

POWER SWITCHBOARDS



QEM/3 Electrical panel for 3" submersible pumps

TYPE	CODE	POWER MOTOR (P ₂)		CAPACITOR	CURRENT POWER
		kW	HP	CAPACITY	A
Single-phase					
QEM/3-050	530ECS305A1	0.37	0.50	12.5 µF	5
QEM/3-075	530ECS307A1	0.55	0.75	16 µF	6
QEM/3-100	530ECS310A1	0.75	1	20 µF	7
QEM/3-150	530ECS315A1	1.1	1.5	30 µF	10

※ Single-phase 230 V 50 Hz



QEM Electrical panel for 4" single-phase submersible pumps

TYPE	CODE	POWER MOTOR (P ₂)		CAPACITOR	CURRENT POWER
		kW	HP	CAPACITY	A
Single-phase					
QEM 050	530ECN05A1	0.37	0.50	20 µF	5
QEM 075	530ECN07A1	0.55	0.75	25 µF	6
QEM 100	530ECN10A1	0.75	1	35 µF	7
QEM 150	530EC15A1	1.1	1.5	40 µF	11
QEM 200	530ECN20A1	1.5	2	60 µF	13
QEM 300	530EC30A1	2.2	3	75 µF	18

※ Single-phase 230 V 50 Hz



QET Electrical panel for 3", 4" and 6" three-phase submersible pumps

TYPE	CODE	POWER MOTOR (P ₂)		CURRENT POWER
		kW	HP	A
Three-phase				
QET 050	530TNF05A	0.37	0.50	1.7
QET 075	530TNF07A	0.55	0.75	2
QET 100	530TNF10A	0.75	1	2.5
QET 150	530TNF15A	1.1	1.5	3.9
QET 200	530TNF20A	1.5	2	4.8
QET 300	530TNF30A	2.2	3	7
QET 400	530TNF40A	3	4	9
QET 550	530TNF55A	4	5.5	11.5
QET 750	530TNF75A	5.5	7.5	15.5
QET 1000	530AD100A	7.5	10	21.5
QET 1250	530AD125A	9.2	12.5	23.5
QET 1500	530AD150A	11	15	27.5
QET 2000	530AD200A	15	20	36
QET 2500	530AD250A	18.5	25	45
QET 3000	530AD300A	22	30	54
QET 4000	530AD400A	30	40	68
QET 5000	530AD500A	37	50	85

※ The electrical panel is equipped with a selector switch for manual or automatic operation with provision for connecting a float switch (or pressure switch, etc.).

※ Three-phase 400 V - 50 Hz

QSM Single-phase 4" pump electrical panel with level probes



Probes indicator

TYPE	CODE	POWER MOTOR (P ₂)		CAPACITOR	CURRENT POWER
		kW	HP	CAPACITY	A
Single-phase					
QSM 050	530MFLCN05A1	0.37	0.50	20 µF	5
QSM 075	530MFLCN07A1	0.55	0.75	25 µF	6
QSM 100	530MFLCN10A1	0.75	1	35 µF	7
QSM 150	530MFLC15A1	1.1	1.5	40 µF	11
QSM 200	530MFLCN20A1	1.5	2	60 µF	13
QSM 300	530MFLC30A1	2.2	3	75 µF	18

※ The electrical panel features a selector switch allowing for either manual or automatic operation. It comes preconfigured to connect with devices like a float switch, pressure switch, or level probes, offering protection against the pump running dry.

※ **Single-phase 230 V 50 Hz**

QST Electrical panel for 3", 4" and 6" three-phase pumps with level probes



Probes indicator

TYPE	CODE	MOTOR POWER (P ₂)		CURRENT POWER
		kW	HP	A
Three-phase				
QST 50	530TFLC05A	0.37	0.50	1.7
QST 75	530TFLC07A	0.55	0.75	2
QST 100	530TFLC10A	0.75	1	2.5
QST 150	530TFLC15A	1.1	1.5	3.9
QST 200	530TFLC20A	1.5	2	4.8
QST 300	530TFLC30A	2.2	3	7
QST 400	530TFLC40A	3	4	9
QST 550	530TFLC55A	4	5.5	11.5
QST 750	530TFLC75A	5.5	7.5	15.5
QST 1000	530ADL100A	7.5	10	21.5
QST 1250	530ADL125A	9.2	12.5	23.5
QST 1500	530ADL150A	11	15	27.5
QST 2000	530ADL200A	15	20	36
QST 2500	530ADL250A	18.5	25	45
QST 3000	530ADL300A	22	30	54
QST 4000	530ADL400A	30	40	68
QST 5000	530ADL500A	37	50	85

※ The electrical panel features a selector switch allowing for either manual or automatic operation. It comes preconfigured to connect with devices like a float switch, pressure switch, or level probes, offering protection against the pump running dry.

※ **Three-phase 400 V - 50 Hz**

POWER SWITCHBOARDS

QES Electrical panel for three-phase drainage pumps



TYPE	CODE	POWER MOTOR (P ₂)		CURRENT POWER A
		kW	HP	
Three-phase				
QES 150	532QES150A	1.1	1.5	4.2
QES 200	532QES200A	1.5	2	5.2
QES 300	532QES300A	2.2	3	6.5
QES 400	532QES400A	3	4	8

※ The electrical panel features a selector switch allowing for either manual or automatic operation. It comes preconfigured to connect with devices like a float switch and the integrated thermal protector for VXC, VXC-F, MC, MC-F drainage pumps

※ **Three-phase 380 - 415V 50 Hz**



ALARM KIT Electronic panel for SAR 250 and SAR 550

TYPE	CODE	VOLTAGE
ALARM KIT	KSKIT-ALARM	single-phase 230V 50 Hz

※ The panel contains an electronic board, a buffer battery to power the panel, a red flashing light and a 90 dB alarm siren at 1 m.

※ The panel is preconfigured for the connection of a float switch (included in the kit) that triggers the alarm when the contact is closed.



SF

SF - SPHERICAL TANK

TYPE	CODE	FITTING	CAPACITY	PALLET CAPACITY No. of tanks
24 SF	50011	1"	24 litres	54

※ Maximum operating pressure **8 bar** - Interchangeable butyl rubber diaphragm



CL

CL - CYLINDRICAL TANKS

TYPE	CODE	FITTING	CAPACITY	PALLET CAPACITY No. of tanks
24 CL	50012	1"	20 litres	56
60 CL	50031	1"	60 litres	15
100 CL	50032	1"	100 litres	12

※ Maximum operating pressure **10 bar** - Interchangeable butyl rubber diaphragm



VT

VT - VERTICAL TANKS

TYPE	CODE	FITTING	CAPACITY	PALLET CAPACITY No. of tanks
8 VT	50051	1"	8 litres	189
19 VT	50052	1"	19 litres	63
60 VT	50040	1"	60 litres	15
100 VT	50041	1"	100 litres	12
200 VT	50042	1½"	200 litres	6
300 VT	50043	1½"	300 litres	6

※ Maximum operating pressure **10 bar (8 bar for 8VT, 19VT)** - Interchangeable butyl rubber diaphragm

REPLACEMENT MEMBRANE

24 SF	CODE 50019
24 CL	CODE 50019
60 CL	CODE 5001960
100 CL	CODE 50019100

REPLACEMENT MEMBRANE

8 VT	CODE 5001905/8
19 VT	CODE 50019
60 VT	CODE 5001960
100 VT	CODE 50019100
200 VT	CODE 50019200C
300 VT	CODE 50019300



1SF

05SF

SF - SPHERICAL TANKS WITH FIXED MEMBRANE

TYPE	CODE	FITTING	CAPACITY
05SF 0.5	500570045	½"	½ litre
05SF 1.0	500570090	1"	½ litre
1SF 0.5	50057005	½"	1 litre
1SF 1.0	50057010	1"	1 litre

※ Maximum operating pressure **10 bar**

※ Start of production: 03.2024 for 1SF – 07.2024 for 05SF

ACCESSORIES

KSP-24



PSG-1



FSG2

ROUND TANK KIT

TYPE	CODE
KSP-24 ※ 24-litre round tank ※ Pressure gauge 0 - 6 bar. ※ 5-way fitting - G 1" ※ Pressure switch 'PSG-1'	50008SP24
KSD-24 ※ 24-litre round tank ※ Pressure gauge 0 - 6 bar. ※ 5-way fitting - G 1" ※ Pressure switch 'FSG2'	50010

KCP-24



PSG-1



FSG2

CYLINDER KITS

TYPE	CODE
KCP-24 ※ 20-litres cylindrical tank ※ Pressure gauge 0 - 6 bar. ※ 5-way fitting - G 1" ※ Hose G 1" (500 mm) ※ Pressure switch 'PSG-1'	50008CP24
KCD-24 ※ 20-litre cylindrical tank ※ Pressure gauge 0 - 6 bar. ※ 5-way fitting - G 1" ※ Hose G 1" (500 mm) ※ Pressure switch 'FSG2'	50009

KCP-60



PSG-1



FSG2

TYPE	CODE
KCP-60 ※ 60-litre cylindrical tank ※ Pressure gauge 0 - 6 bar. ※ 5-way fitting - G 1" ※ Hose G 1" (600 mm) ※ Pressure switch 'PSG-1'	50008CP60
KCD-60 ※ 60-litre cylindrical tank ※ Pressure gauge 0 - 6 bar. ※ 5-way fitting - G 1" ※ Hose G 1" (600 mm) ※ Pressure switch 'FSG2'	50009/67

ACCESSORIES FOR ELECTRIC SUBMERSIBLE PUMPS



TYPE	CODE	CABLE DIAMETER	CABLE WEIGHT	TENSILE STRENGTH
SAFETY CABLE (in polypropylene)	116310	Ø 8 mm	30 gr/m	960 kg
	116311	Ø 10 mm	45 gr/m	1425 Kg
	116312	Ø 12 mm	65 gr/m	2030 kg
	116313	Ø 14 mm	90 gr/m	2790 kg
	116314	Ø 16 mm	115 gr/m	3500 kg

- ※ Twisted cable made of UV-stabilised polypropylene yarn
- ※ Maximum available reel length: 220 metres



SAFETY CABLE (AISI 316 stainless steel)	116305	Ø 5 mm	100 gr/m	1500 kg
--	--------	--------	----------	---------

- ※ 49 wire cable in AISI 316 stainless steel
- ※ Maximum available reel length: 250 metres



STRAIGHT SHACKLE WITH PIN (For 8 mm cable) (in AISI 316 stainless steel)	CODE 1160305
--	--------------



5 mm CABLE CLAMP (in AISI 316 stainless steel)	CODE 1160304
---	--------------

FLOAT SWITCHES



TYPE	CODE		LENGTH
	CABLE = H07 RN-F	PVC CABLE	
0315/3	50014H	50014	3 metres
0315/5	500145H	500145	5 metres
0315/10	5001410H	5001410	10 metres

- ※ With cable **H07 RN-F**: single function (emptying), with 10 A switch
- ※ With cable **PVC**: dual function (emptying and filling), with 10 A switch



T 80/3	50014/1H	50014/1	3 metres
T 80/5	50014/5H	50014/5	5 metres
T 80/10	50014/10H	50014/10	10 metres

- ※ With **H07 RN-F** cable: single-function (emptying), double sealed float switches, with 10 A switch
- ※ With **PVC** cable: dual-function (emptying and filling), double sealed float switches, with 10 A switch



SMALL 3	50014S4	50014S3	3 metres
SMALL 5	50014S5	50014S51	5 metres

- ※ With **H07 RN-F** cable: single-function (emptying), double sealed float switches, with 10 A switch
- ※ With **PVC** cable: dual-function (emptying and filling), double sealed float switches, with 10 A switch



TYPE	CODE	CABLE	LENGTH
MAC 5	54SARGL001	PVC	10 metres

- ※ Tilting float: dual function (emptying and filling), double sealed protection chamber, with 10 A switch
- ※ Recommended for Waste Water Recovery Stations (SAR)

ACCESSORIES



AIRFLO - AIR FEEDERS

TYPE	CODE	TANK CAPACITY
AIRFLO 1	50021	100 + 500 litres
AIRFLO 2	50022	750 + 2000 litres

※ Air feeders suitable for maintaining the air cushion in autoclave tanks without a membrane.

NA - 3-WAY NIPPLE FOR AIR FEEDERS

TYPE	CODE	FITTING	DOUBLE CENTRAL ATTACK
NA < 1.00	50023	1" x 1"	½" x ¼" (male/female)
NA < 1.25	50023/1	1¼" x 1¼"	½" x ¼" (male/female)
NA < 1.50	50023/2	1½" x 1½"	½" x ¼" (male/female)
NA < 2.00	50023/3	2" x 2"	½" x ¼" (male/female)

※ 3-way brass fittings for air supply connections (AIRFLO)



PSG



FSG

PRESSURE SWITCHES

TYPE	CODE	FITTING	CALIBRATION (*)
PSG-1	50018/8	¼" Female	1.4 – 2.8 bar
PSG-1M	50018/8M	¼" Male	1.4 – 2.8 bar
FSG 2	50018	¼" Female	1.4 – 2.8 bar
FYG 22	50018/1	¼" Female	5.4 – 7.0 bar
FYG 32	50018/2	¼" Female	8 – 10.5 bar
PT/5 SK (Three-phase)	50018/8T	¼" Female	1.4 – 2.8 bar

※ PSG registered Community model no. 002248955

(*) Adjustable



MC



MR



MCG



MRG

PRESSURE GAUGES

TYPE	CODE	FITTING	DIAMETER	SCALE
MC 6	50015/2	¼" - central	50 mm	0 – 6 bar
MR 6	50015	¼" - radial	63 mm	0 – 6 bar
MR 10	50015/0	¼" - radial	63 mm	0 – 10 bar

GLYCERINE BATH PRESSURE GAUGES

TYPE	CODE	FITTING	DIAMETER	SCALE
MCG 6	50015/2G	¼" - central	50 mm	0 – 6 bar
MRG 6	50015G	¼" - radial	63 mm	0 – 6 bar
MRG 10	50015/0G	¼" - radial	63 mm	0 – 10 bar



FITTINGS 3-5 WAYS

TYPE	CODE	FITTING
R 3 - 3 vie	50017	1"
R 4 - 4 vie	50016V8	1"
R 5 - 5 vie	50016	1"

※ R 3: three-way brass fitting with **G 1"** connections

※ R 4: four-way brass fitting with **G ½"** and **G ¼"** connections

※ R 5: five-way brass fitting with **G 1"** and **G ¼"** connections



HOSES

TYPE	CODE	TUBE	FITTINGS	LENGTH
TF 5	50013	1"	1" x 1"	500 mm
TF 6	50013/1	1"	1" x 1"	600 mm
TF 10	50013/6	1"	1" x 1"	1000 mm

※ EPDM rubber hoses

※ Maximum operating pressure **10 bar**

HOSES COMPLETE WITH ELBOW

TYPE	CODE	TUBE	FITTINGS	LENGTH
TFG 5	50013/01	¾"	1" x 1"	500 mm
TFG 6	50013/10	1"	1" x 1"	600 mm

※ EPDM rubber hoses

※ Maximum operating pressure **10 bar**



QUICK RELEASE COUPLINGS

TYPE	CODE	Hose connector diameter	Male union thread
FASTFIT 1.25	5027125	Ø 32 mm	1¼"
FASTFIT 1.5	5027150	Ø 38 mm	1½"
FASTFIT 2	5027200	Ø 50 mm	2"
FASTFIT 3	5027300	Ø 75 mm	3"

※ CAMLOCK polypropylene quick release coupling kit: - n.1 female coupling with hose connector - n.1 male coupling with male thread



HOSE FITTINGS

TYPE	CODE	RUBBER HOLDER	THREADED CONNECTOR
RP 0.75	50210	Ø 25 mm	¾"
RP 1	50211	Ø 30 mm	1"
RP 1.25	50212	Ø 35 mm	1¼"
RP 1.5	50213	Ø 40 mm	1½"
RP 2	50214	Ø 50 mm	2"
RPG 0.75	50220	Ø 25 mm	¾"
RPG 1	50221	Ø 30 mm	1"
RPG 1.25	50222	Ø 35 mm	1¼"
RPG 1.5	50223	Ø 40 mm	1½"
RPG 2	50224	Ø 50 mm	2"

※ Nylon fittings

ACCESSORIES



VF - FOOT VALVES

TYPE	CODE	FITTING
VF 0.5	50100	1/2"
VF 0.75	50101	3/4"
VF 1	50102	1"
VF 1.25	50103	1 1/4"
VF 1.5	50104	1 1/2"
VF 2	50105	2"

※ Brass foot valves with stainless steel suction filter



VR - CHECK VALVES

TYPE	CODE	FITTINGS
VR 0.5	50110	1/2"
VR 0.75	50111	3/4"
VR 1	50112	1"
VR 1.25	50113	1 1/4"
VR 1.5	50114	1 1/2"
VR 2	50115	2"

※ Brass check valves



VR-FT - BALL CHECK VALVES

TYPE	CODE	FITTINGS
VR-FT 1.25	501201	1 1/4"
VR-FT 1.5	501202	1 1/2"
VR-FT 2	501203	2"

※ Check valves for submersible pumps (sewage)

※ Max. operating pressure **16 bar**

※ Min. operating pressure **0.3 bar**

※ Operating temperature 0 °C - **+80 °C**



VR-FF - BALL CHECK VALVES

TYPE	CODE	FITTINGS
VR-FF/DN 65 - FLANGED	501210	DN 65 (PN16) 2 1/2"
VR-FF/DN 80 - FLANGED	501212	DN 65 (PN16) 2 1/2"
VR-FF/DN 100 - FLANGED	501214	DN 65 (PN16) 2 1/2"

※ Check valves for submersible pumps (sewage).

※ Max. operating pressure **16 bar**

※ Min. operating pressure **0.3 bar**

※ Operating temperature 0 °C - **+80 °C**

SCHUKO SOCKET WITH PROTECTIVE SHELLS



TYPE	CODE
PSC	117985

- ※ Water and dust protection with IP 65 or IP 67 rating
- ※ Mechanical protection from tearing

ELECTRIC CABLES FOR ELECTRIC SUBMERSIBLE PUMPS



TYPE	CODE	TYPE	WEIGHT PER METRE
4 x 1 mm ²	117G100AN	H07 RN-F	0.165 kg
4 x 1.5 mm ²	117G150AN	H07 RN-F	0.205 kg
4 x 2.5 mm ²	117G200AN	H07 RN-F	0.290 kg
4 x 4 mm ²	117G250AN	H07 RN-F	0.420 kg
4 x 6 mm ²	117G300AN	H07 RN-F	0.505 kg
4 x 10 mm ²	117G350AN	H07 RN-F	1.030 Kg
4 x 16 mm ²	117G400AN	H07 RN-F	2.050 Kg

CABLES WITH PLUG



TYPE	CODE	CABLE SECTION	LENGTH	PLUG
H05 VV-F (PVC)	117FGA21G	3 x 0.75 mm ²	150 cm	SCHUKO
H07 RN-F (NEOPRENE)	117GLA21G	3 x 1 mm ²	150 cm	SCHUKO

ELECTRICAL CABLES FOR PHOTOVOLTAIC SYSTEMS



FG21M21 TYPE	CODE	WEIGHT PER METRE
1 x 4 mm ² colour red	117SF104R	0.060 kg
1 x 4 mm ² colour black	117SF104N	0.060 kg
1 x 6 mm ² colour red	117SF106R	0.080 kg
1 x 6 mm ² colour black	117SF106N	0.080 kg

ACCESSORIES

F - FILTER HOLDER WITH PLASTIC HEADER



TYPE	CODE	THREADED FITTINGS	HEIGHT CARTRIDGE
MEDIUM - F 0.75	504F075M	¾"	5"
MEDIUM - F 1	504F100M	1"	5"
JUNIOR - F 0.75	504F075J	¾"	7"
JUNIOR - F 1	504F100J	1"	7"
SENIOR - F 0.75	504F075S	¾"	10"
SENIOR - F 1	504F100S	1"	10"

※ Maximum operating pressure **5 bar** (at +20 °C)

※ Maximum temperature + **45 °C** (at 2 bar pressure)



SPANNER FOR DISASSEMBLY OF F-HOLDER CONTAINER

(code: 504KNPP)

RL - POLYESTER FILTER CARTRIDGES



TYPE	CODE	FILTRATION	HEIGHT CARTRIDGE	TYPE FILTER HOUSING
RL 5	504C05	50 µ	5"	MEDIUM F
RL 7	504C07	50 µ	7"	JUNIOR F
RL 10	504C10	50 µ	10"	SENIOR F

FA - POLYPROPYLENE FILTER CARTRIDGES



TYPE	CODE	FILTRATION	HEIGHT CARTRIDGE	TYPE FILTER HOUSING
FA 5	504F05	50 µ	5"	MEDIUM F
FA 7	504F07	50 µ	7"	JUNIOR F
FA 10	504F10	50 µ	10"	SENIOR F



HA - FILTER CARTRIDGE WITH POLYPHOSPHATE CRYSTALS

TYPE	CODE	HEIGHT CARTRIDGE	TYPE FILTER HOUSING
HA 10	504F08	10"	SENIOR F



LA - ACTIVATED CARBON FILTER

TYPE	CODE	HEIGHT CARTRIDGE	TYPE FILTER HOUSING
LA 10 BX	504LA10BX	10"	SENIOR F



GARDEN KIT - FLEXIBLE SUCTION HOSE

TYPE	CODE	FITTING	LENGTH
GARDEN KIT	50200	1"	7 metres

※ Flexible hose, complete with foot valve



TEFLON FOR HYDRAULIC JOINTS

TYPE	CODE	LENGTH	TAPE WIDTH
TFN 1	14TFN/1	12 m	12 mm
TFN 2	14TFN/21	30 m	12 mm
TFN 3	14TFN/3	12 m	19 mm



SPRAY CAN

TYPE	CODE	COLOUR	CAPACITY
SPRAY PAINT 1	120200A/2	Pedrollo blue	400 ml



※ RECOMMENDED

CAST RESIN CABLE JOINTING KIT

TYPE	CODE	NUMBER CONDUCTORS	SECTION CABLES	INSIDE DIAMETER FITTING
RPS 1	530GT3M82A1	4	1 - 4 mm ²	Ø 38 mm
RPS 2	530GT3M82A2	4	1 - 10 mm ²	Ø 32 mm
RPS 3	530GT3M92A1	4	6 - 16 mm ²	Ø 36 mm



※ ECONOMICAL

HEAT SHRINKABLE CABLE SPLICE KIT

TYPE	CODE	NUMBER CONDUCTORS	SECTION CABLES
GPS 1	530GT3MGPS1	4	1 - 2.5 mm ²
GPS 2	530GT3MGPS2	4	4 - 6 mm ²

ACCESSORIES

BEARINGS FOR PUMPS AND MOTORS



TYPE	CODE	DIMENSIONS
6201 ZZ	113001	12 x 32 x 10 mm
6201 ZZ - C3E	113001C3E	12 x 32 x 10 mm
6201 2RS - C3	113001SC3E	12 x 32 x 10 mm
6202 ZZ - C3	113012	15 x 35 x 11 mm
6203	113002A	17 x 40 x 12 mm
6203 ZZ	113002	17 x 40 x 12 mm
6203 ZZ - C3E	113002C3E	17 x 40 x 12 mm
6203 2RS - C3E	113002RC3E	17 x 40 x 12 mm
6204 ZZ - C3	113003C3E	20 x 47 x 14 mm
6204 ZZ - C3E	113003	20 x 47 x 14 mm
6204 2RS - C3E	113004RC3E	20 x 47 x 14 mm
6205 ZZ	113004	25 x 52 x 15 mm
6206 ZZ - C3	113005C3E	30 x 62 x 16 mm
6208 ZZ - C3	113008	40 x 80 x 18 mm
6003 ZZ - C3	113010	17 x 35 x 10 mm
6212 ZZ - C3	113020	60 x 110 x 22 mm
6302	1130145	15 x 42 x 13 mm
6303 2RS - C3	113014SC3	17 x 47 x 14 mm
6304 ZZ	113013	20 x 52 x 15 mm
6304 ZZ - C3	113013C3E	20 x 52 x 15 mm
6304 2RS - C3	113013SC3	20 x 52 x 15 mm
6305	113043	25 x 62 x 17 mm
6306 ZZ - C3	113015	30 x 72 x 19 mm
6307 ZZ - C3	113017	35 x 80 x 21 mm
6308 ZZ - C3	113018	40 x 90 x 23 mm
6308 2RS - C3	113025	40 x 90 x 23 mm
6309 ZZ - C3	1130185	45 x 100 x 25 mm
6310 ZZ - C3	113019	50 x 110 x 27 mm
6312 ZZ - C3	113021	60 x 130 x 31 mm
6313 ZZ - C3	113023	65 x 140 x 33 mm
6314 ZZ - C3	113024	70 x 150 x 35 mm
3203 B 2RS - C3	113040RC3E	17 x 40 x 17.5 mm
3304 B ZZ - C3	113041	20 x 52 x 22.2 mm
3305 B 2RS - C3	113042	25 x 62 x 25.4 mm
3308 A 2RS - C3	113044	40 x 90 x 36.5 mm
7202 B	113029	15 x 35 x 22.2 mm

FANS FOR PUMPS AND MOTORS



TYPE	CODE	DIMENSIONS	SHAFT DIAMETER
FAN-63	14VN059	104 x 21 mm	12 mm
FAN-63/1	14VN067	99 x 22 mm	12 mm
FAN-63/2	14VN068	99 x 26 mm	12 mm
FAN-71R	14VN07	125 x 24 mm	14.5 mm
FAN-71	14VN076	114 x 20 mm	14.5 mm
FAN-71/1	14VN072	116 x 23 mm	14.5 mm
FAN-80R	14VN08	138 x 27 mm	20 mm
FAN-80	14VN08181	126 x 26 mm	20 mm
FAN-90R	14VN09	162 x 32 mm	24 mm
FAN-90	14VN095	148 x 33 mm	24 mm
FAN-100R	14VN10	176 x 38 mm	28 mm
FAN-100	14VN10162	155 x 37 mm	28 mm
FAN-132	14VN132	165 x 45 mm	36 mm
FAN-180	14VN180	240 x 60 mm	55 mm
FAN-250	14VN250	230 x 90 mm	63 mm

CAPACITORS WITH FASTON CONNECTIONS



TYPE F
Capacitor with faston

TYPE	CODE	CAPACITY	Voltage	Frequency
10 F	111010F	10 μF	450 VL	50 – 60 Hz
10 FC *	111010FC	10 μF	450 VL	50 – 60 Hz
12 F	111012F	12.5 μF	450 VL	50 – 60 Hz
14 F	111014F	14 μF	450 VL	50 – 60 Hz
16 F - 500	111016F5	16 μF	500 VL	50 – 60 Hz
16 F - 450	111016F		450 VL	50 – 60 Hz
16 F - 250	112016F		250 VL	50 – 60 Hz
20 F - 500	111020F5	20 μF	500 VL	50 – 60 Hz
20 F - 450	111020F		450 VL	50 – 60 Hz
25 F - 450	111025F	25 μF	450 VL	50 – 60 Hz
25 F - 250	112025F		250 VL	50 – 60 Hz
30 F - 250	112030F	30 μF	250 VL	50 – 60 Hz
31 F	111031F	31.5 μF	450 VL	50 – 60 Hz
35 F	111035F	35 μF	450 VL	50 – 60 Hz
35 FC *	111035F1	35 μF	450 VL	50 – 60 Hz
40 F	111040F	40 μF	450 VL	50 – 60 Hz
45 F	111045F	45 μF	450 VL	50 – 60 Hz
50 F	111050F	50 μF	450 VL	50 – 60 Hz
60 F - 450	111060F	60 μF	450 VL	50 – 60 Hz
60 F - 300	112061F		300 VL	50 – 60 Hz
60 F - 250	112060F		250 VL	50 – 60 Hz
70 F	111070F	70 μF	450 VL	50 – 60 Hz
80 F	112080F	80 μF	250 VL	50 – 60 Hz
90 F	111090F	90 μF	450 VL	50 – 60 Hz

(*) FC = Special small capacitor

※ VDE-IMQ approved capacitors

CAPACITORS WITH OUTGOING CABLES



TYPE C
Capacitor with outgoing cables

TYPE	CODE	CAPACITY	Voltage	Frequency
10 C	1110102F	10 μF	450 VL	50 – 60 Hz
12 C	1110122F	12.5 μF	450 VL	50 – 60 Hz
16 C - 500	1110162F5	16 μF	500 VL	50 – 60 Hz
16 C - 450	1110162F		450 VL	50 – 60 Hz
20 C - 500	1110202F5	20 μF	500 VL	50 – 60 Hz
20 C - 450	1110202F		450 VL	50 – 60 Hz
25 C - 450	1110252F	25 μF	450 VL	50 – 60 Hz
30 C - 250	1120302F	30 μF	250 VL	50 – 60 Hz
31 C - 500	1110312F5	31.5 μF	500 VL	50 – 60 Hz
31 C - 450	1110312F		450 VL	50 – 60 Hz
35 C - 500	1110352F5	35 μF	500 VL	50 – 60 Hz
35 C - 450	1110352F		450 VL	50 – 60 Hz
35 CC * - 450	1110352F1		450 VL	50 – 60 Hz
40 C	1110402F	40 μF	450 VL	50 – 60 Hz
50 C	1110502F	50 μF	450 VL	50 – 60 Hz
60 C	1120602F	60 μF	250 VL	50 – 60 Hz
70 C - 450	1110702F	70 μF	450 VL	50 – 60 Hz
70 C - 250	1120702F5	70 μF	250 VL	50 – 60 Hz
75 C	1110752F	75 μF	450 VL	50 – 60 Hz
80 C - 250	1120802F	80 μF	250 VL	50 – 60 Hz
80 C - 450	1110802FC	80 μF	450 VL	50 – 60 Hz
100 C	1111002FC	100 μF	450 VL	50 – 60 Hz

(*) CC = Special small capacitor

※ VDE-IMQ approved capacitors



CAPACITOR WITH CIRCUIT BREAKER

TYPE	CODE	CAPACITY	Voltage	Frequency
80 D	111080D2F	80 μF	320-480 VL	50 – 60 Hz

※ Capacitor for submersible pumps with grinder (TRITUS)

BEARINGS

MODEL	BEARINGS	
2CP		
2CP 25/130	6203 ZZ	6203 ZZ
2CP 25/14	6204 ZZ - C3	6204 ZZ - C3
2CP 25/16		
2CP 32/200	6206 ZZ - C3	6206 ZZ - C3
2CP 32/210		
2CP 40/180	6306 ZZ - C3	6206 ZZ - C3
2CP 40/200	6308 ZZ - C3	6308 ZZ - C3
2-5CP		
2-3-4CP 80	6202 ZZ - C3	6201 ZZ
3CP 100		
4CP 100	6203 ZZ	6203 ZZ
5CP 80-100 I		
2-5CR		
2-3-4CR 80	6202 ZZ - C3	6201 ZZ
3CR 100		
4CR 100	6203 ZZ	6203 ZZ
5CR 80-100		
4BLOCK		
4BLOCK	6203	6203
BC		
BC 10	6203 ZZ - C3	6203 ZZ - C3
BC 15-20	6303 2RS - C3	6203 ZZ - C3
BC 40-55-75	6306 ZZ - C3	6304 ZZ - C3
BC -MF		
BC 10 -MF	6203 ZZ - C3	6203 ZZ - C3
BC 15-20 -MF	6303 2RS - C3	6203 ZZ - C3
BC -ST		
BC 10 -ST	6203 ZZ - C3	6203 ZZ - C3
BC 15-20 -ST	6303 2RS - C3	6203 ZZ - C3
CK		
CK 50	6201 ZZ	6201 ZZ
CKR		
CKR 90	6203 ZZ	6203 ZZ
CP		
CP 100-130-132	6201 ZZ	6201 ZZ
CP 150-158	6203 ZZ	6203 ZZ
CP 160-170	6204 ZZ - C3	6204 ZZ - C3
CP 190-200	6304 ZZ	6204 ZZ - C3
CP 210	6307 ZZ - C3	6206 ZZ - C3
CP 220C	6206 ZZ - C3	6204 ZZ - C3
CP 220AH-A-B		
CP 230A-B-C	6307 ZZ - C3	6206 ZZ - C3
CP 250B		
CP 250A	6310 ZZ - C3	6308 ZZ - C3
CP ST4-ST6		
CP 100-130-132 ST4-ST6	6201 ZZ	6201 ZZ
CP 150-158 ST4-ST6	6203 ZZ	6203 ZZ
CP 170-180-190-200 ST4-ST6	6204 ZZ - C3	6204 ZZ - C3
D		
D 8-10-20	6203 ZZ - C3	6203 ZZ - C3
D 30	6303 2RS - C3	6203 ZZ - C3

MODEL	BEARINGS	
DAVIS		
DAVIS	6203 ZZ - C3	6203 ZZ - C3
DC		
DC 8-10-20-30	6203 ZZ - C3	6203 ZZ - C3
DC 42-43-44	3305B 2RS	6204 ZZ - C3
DG-BLU		
DG-BLU	6203 ZZ	6203 ZZ
F		
F 32/160	6306 ZZ - C3	6206 ZZ - C3
F 32/200	6307 ZZ - C3	6206 ZZ - C3
F 32/250	6310 ZZ - C3	6308 ZZ - C3
F 40/125	6206 ZZ - C3	6204 ZZ - C3
F 40/160	6306 ZZ - C3	6206 ZZ - C3
F 40/200	6307 ZZ - C3	6206 ZZ - C3
F 40/250	6310 ZZ - C3	6308 ZZ - C3
F 50/125	6306 ZZ - C3	6206 ZZ - C3
F 50/160	6307 ZZ - C3	6206 ZZ - C3
F 50/200	6310 ZZ - C3	6308 ZZ - C3
F 50/250		
F 65/125	6307 ZZ - C3	6206 ZZ - C3
F 65/160		
F 65/200	6310 ZZ - C3	6308 ZZ - C3
F 80/160		
F 100/160		
F 65/250		
F 80/200	6312 ZZ - C3	6212 ZZ - C3
F 80/250B		
F 80/250A	6314 ZZ - C3	6313 ZZ - C3
F 100/200	6312 ZZ - C3	6212 ZZ - C3
F 100/250	6314 ZZ - C3	6313 ZZ - C3
F -INOX		
F 50/160 -I		
F 65/125 -I	6307 ZZ - C3	6206 ZZ - C3
F4		
F4 32/160	6206 ZZ - C3	6204 ZZ - C3
F4 32/200	6307 ZZ - C3	6206 ZZ - C3
F4 32/250	6208 ZZ - C3	6206 ZZ - C3
F4 40/160	6206 ZZ - C3	6204 ZZ - C3
F4 40/200	6307 ZZ - C3	6206 ZZ - C3
F4 40/250	6208 ZZ - C3	6206 ZZ - C3
F4 50/125	6206 ZZ - C3	6204 ZZ - C3
F4 50/160	6307 ZZ - C3	6206 ZZ - C3
F4 50/200		
F4 50/250	6208 ZZ - C3	6206 ZZ - C3
F4 65/125	6307 ZZ - C3	6206 ZZ - C3
F4 65/160		
F4 65/200	6208 ZZ - C3	6206 ZZ - C3
F4 65/250	6310 ZZ - C3	6308 ZZ - C3
F4 80/160	6208 ZZ - C3	6206 ZZ - C3
F4 80/200		
F4 80/250	6310 ZZ - C3	6308 ZZ - C3
F4 100/160	6208 ZZ - C3	6206 ZZ - C3
F4 100/200		
F4 100/250	6310 ZZ - C3	6308 ZZ - C3

MODEL	BEARINGS	
F4 -INOX		
F4 50/160 -I		
F4 65/125 -I	6307 ZZ - C3	6206 ZZ - C3
FAMILY		
FAMILY	6201 ZZ	6201 ZZ
FCR		
FCR 15-30	6307 ZZ - C3	6206 ZZ - C3
FCR 80/2-3-4	6202 ZZ - C3	6201 ZZ
FCR 80/5	6203 ZZ	6203 ZZ
FCR 90-130-200-240	6304 2RS - C3	6204 ZZ - C3
FCR 100/3	6202 ZZ - C3	6201 ZZ
FCR 100/4-5	6203 ZZ	6203 ZZ
FG		
FG 32/160		
FG 32/200	6307 ZZ - C3	6307 ZZ - C3
FG 32/250	6307 ZZ - C3	6208 ZZ - C3
FG 40/125		
FG 40/160	6307 ZZ - C3	6307 ZZ - C3
FG 40/200		
FG 40/250	6307 ZZ - C3	6208 ZZ - C3
FG 50/125		
FG 50/160	6307 ZZ - C3	6307 ZZ - C3
FG 50/200		
FG 50/250	6307 ZZ - C3	6208 ZZ - C3
FG 65/125		
FG 65/160	6307 ZZ - C3	6307 ZZ - C3
FG 65/200		
FG 65/250	6309 ZZ - C3	6309 ZZ - C3
FG 80/160	6307 ZZ - C3	6307 ZZ - C3
FG 80/200		
FG 80/250	6309 ZZ - C3	6309 ZZ - C3
FG 100/160	6307 ZZ - C3	6307 ZZ - C3
FG 100/200		
FG 100/250	6309 ZZ - C3	6309 ZZ - C3
FLUID SOLAR		
FLUID SOLAR 1/10, 2/6, 4/4, 6/3	6203 2RS - C3	6203 ZZ - C3
FLUID SOLAR 1/20, 2/14, 4/8, 6/6	3203B 2RS - C3	6203 ZZ - C3
FUTURE JET		
FUTURE-JET 1	6201 ZZ	6201 ZZ
FUTURE-JET 2	6203 ZZ	6203 ZZ
FUTURE JET-ST		
FUTURE-JET 1-ST	6201 ZZ	6201 ZZ
FUTURE-JET 2-ST	6203 ZZ	6203 ZZ
HF		
HF 4-5-51	6203 ZZ	6203 ZZ
HF 50	6201 ZZ	6201 ZZ
HF 5M-70	6204 ZZ - C3	6204 ZZ - C3
HF 6	6304 ZZ	6204 ZZ - C3
HF 8-20	6306 ZZ - C3	6206 ZZ - C3
HF 30	6307 ZZ - C3	6206 ZZ - C3
HT & HT-PRO		
HT & HT-PRO 3/4-5-6-7	6304 2RS - C3	6204 ZZ - C3
HT & HT-PRO 3/8-9-10	6307 2RS - C3	6206 2RS - C3

MODEL	BEARINGS	
HT & HT-PRO 5/2-3-4-5-6	6304 2RS - C3	6204 ZZ - C3
HT & HT-PRO 5/7-8-9-10	6307 2RS - C3	6206 2RS - C3
HT & HT-PRO 8/3-4-5-6	6304 2RS - C3	6204 ZZ - C3
HT & HT-PRO 8/7-8-9-10-11	6307 2RS - C3	6206 2RS - C3
HT & HT-PRO 15/2-3-4-5	6307 2RS - C3	6206 2RS - C3
HT & HT-PRO 15/6-7	3309A 2RS	6308 2RS - C3
HT & HT-PRO 30/2-3-4	6307 2RS - C3	6206 2RS - C3
HT & HT-PRO 30/5-6-7-8	3309A 2RS	6308 2RS - C3
JCR		
JCR 1	6201 ZZ	6201 ZZ
JCR 2	6203 ZZ	6203 ZZ
JSW		
JSW 1	6201 ZZ	6201 ZZ
JSW 2	6203 ZZ	6203 ZZ
JSW 3	6204 ZZ - C3	6204 ZZ - C3
MAGNIFICA		
MAGNIFICA 1-2	6203 2RS - C3	6203 2RS - C3
MAGNIFICA 3-4-5	6204 2RS - C3	6204 2RS - C3
MC		
MC /45	6203 ZZ - C3	6203 ZZ - C3
MC /50-65	6305	6204 ZZ - C3
MC-F		
MC /50-65 -F	6305	6204 ZZ - C3
MC4		
MC4 /55	6309 ZZ - C3	6306 ZZ - C3
MC4 /80	3309B 2RS - C3	6308 ZZ - C3
MK		
MK	6304 ZZ	6204 ZZ - C3
NGA & NGA-PRO		
NGA & NGA-PRO 1-2	6203 ZZ	6203 ZZ
NGA & NGA-PRO 3	6204 ZZ - C3	6204 ZZ - C3
NK		
NK	6303 2RS - C3	6203 ZZ - C3
PK		
PK 60-65	6201 ZZ	6201 ZZ
PK 80-90	6203 ZZ	6203 ZZ
PK 100-200-300	6204 ZZ - C3	6204 ZZ - C3
PKS		
PKS 60-65	6201 ZZ	6201 ZZ
PKS 80	6203 ZZ	6203 ZZ
PLUG & DRAIN		
PLUG & DRAIN	6201 ZZ	6201 ZZ
PLURIJET		
PLURIJET 3-4/80		
PLURIJET 3-4/90	6202 ZZ - C3	6201 ZZ
PLURIJET 5-6/90	6304 2RS - C3	6204 ZZ - C3
PLURIJET 3/100	6202 ZZ - C3	6201 ZZ
PLURIJET 4/100	6203 ZZ	6203 ZZ
PLURIJET 3/120	6202 ZZ - C3	6201 ZZ
PLURIJET 4/120	6203 ZZ	6203 ZZ
PLURIJET /130-200	6304 2RS - C3	6204 ZZ - C3

BEARINGS

MODEL	BEARINGS	
PQ		
PQ 60-61-65	6201 ZZ	6201 ZZ
PQ 80-90	6203 ZZ	6203 ZZ
PQ 100-200-300	6204 ZZ - C3	6204 ZZ - C3
PQ 3000		
PQ 3000	6204 ZZ - C3	6204 ZZ - C3
PQ-Bs, PQ-PPS		
PQ 60-65-81 Bs PQ81-PPS	6201 ZZ	6201 ZZ
PQA		
PQA 60	6201 ZZ	6201 ZZ
PQA 70-90	6203 ZZ	6203 ZZ
PV		
PV 55-60-65-81	6201 ZZ	6201 ZZ
PV 70-90	6203 ZZ	6203 ZZ
RX		
RX 1-2-3	6201 ZZ	6201 ZZ
RX 4-5	6203 ZZ - C3	6203 ZZ - C3
RX VORTEX		
RX 2-3/20	6201 ZZ	6201 ZZ
RX 4-5/40	6203 ZZ - C3	6203 ZZ - C3
SPRINKLER		
SKR 1.1-1.5	6204 ZZ - C3	6204 ZZ - C3
TEX		
TEX	6201 ZZ	6201 ZZ
TOP		
TOP 1-2-3	6201 ZZ	6201 ZZ
TOP 4-5	6203 ZZ - C3	6203 ZZ - C3
TOP FLOOR		
TOP FLOOR	6201 ZZ	6201 ZZ
TOP MULTI-AD		
TOP MULTI 1-AD	6201 ZZ - C3	6201 ZZ - C3
TOP MULTI		
TOP MULTI 1-2-3	6201 ZZ - C3	6201 ZZ - C3
TOP MULTI 4-5	6302 ZZ	6201 ZZ
TOP MULTI-EVO		
TOP MULTI 1-2-3 EVO	6201 ZZ - C3	6201 ZZ - C3
TOPMULTI 4-5 EVO	6302 ZZ	6201 ZZ
TOP MULTI-TECH		
TOP MULTI TECH 2-3	6202 ZZ - C3	6201 ZZ
TOP MULTI TECH 4-5	6302 ZZ	6201 ZZ
TOP MULTI-EVOTECH		
TOP MULTI EVOTECH 2-3	6202 ZZ - C3	6201 ZZ
TOP MULTI EVOTECH 4-5	6302 ZZ	6201 ZZ
TOP VORTEX		
TOP VORTEX	6201 ZZ	6201 ZZ
TRITUS		
TRITUS TR 0.75-0.9-1.1-1.3	6203 ZZ - C3	6203 ZZ - C3
TRITUS TR 1.5-2.2	3304B ZZ - C3	6304 ZZ - C3
TRITUS TR 2.2AP-3-3AP-4	3305B 2RS	6204 ZZ - C3
TRITUS INOX		
TIG	6303 2RS - C3	6203 ZZ - C3

MODEL	BEARINGS	
UP		
UP	6303 2RS - C3	6203 ZZ - C3
VX		
VX 8-10	6203 ZZ - C3	6203 ZZ - C3
VX 15-20	6303 2RS - C3	6203 ZZ - C3
VX 40-55-75	6306 ZZ - C3	6304 ZZ - C3
VX -MF		
VX 8-10 -MF	6203 ZZ - C3	6203 ZZ - C3
VX 15-20 -MF	6303 2RS - C3	6203 ZZ - C3
VX -ST		
VX 8-10 -ST	6203 ZZ - C3	6203 ZZ - C3
VX 15-20 -ST	6303 2RS - C3	6203 ZZ - C3
VXC		
VXC /35-45	6203 ZZ - C3	6203 ZZ - C3
VXC /50-65	6305	6204 ZZ - C3
VXC-F		
VXC /50-65 -F	6305	6204 ZZ - C3
VXC4		
VXC4 /80	3309B 2RS - C3	6308 ZZ - C3
VXC4 /100	6309 ZZ - C3	6306 ZZ - C3
WR		
WR40-S/125		
WR50-S/125	6203 2RS - C3	6203 2RS - C3
WR50/125	3205A 2RS	6204 2RS - C3
ZX1		
ZXm 1/40	6201 ZZ	6201 ZZ
ZX2		
ZXm 2/30-40	6203 ZZ - C3	6203 ZZ - C3

MODEL	CAPACITOR
2-5CP	
2CPm 80-I	10 μ F - 450 VL
3CPm 100-I	14 μ F - 450 VL
3CPm 80-I	12.5 μ F - 450 VL
4CPm 100-I	20 μ F - 450 VL
4CPm 80-I	14 μ F - 450 VL
5CPm 100-I	25 μ F - 450 VL
5CPm 80-I	20 μ F - 450 VL
2-5CR	
2CRm 80	10 μ F - 450 VL
3CRm 100	14 μ F - 450 VL
3CRm 80	12.5 μ F - 450 VL
4CRm 100	20 μ F - 450 VL
4CRm 80	14 μ F - 450 VL
5CRm 100	25 μ F - 450 VL
5CRm 80	20 μ F - 450 VL
2CP	
2CPm 25/14A	45 μ F - 450 VL
2CPm 25/14B	31.5 μ F - 450 VL
2CPm 25/16A	50 μ F - 450 VL
2CPm 25/16B	45 μ F - 450 VL
2CPm 25/16C	31.5 μ F - 450 VL
2CPm 25/130N	20 μ F - 450 VL
3SR	
3SRm 1/14	12.5 μ F - 450 VL
3SRm 1/21	12.5 μ F - 450 VL
3SRm 1/31	16 μ F - 450 VL
3SRm 1/42	20 μ F - 450 VL
3SRm 1/62	30 μ F - 450 VL
3SRm 2/10	12.5 μ F - 450 VL
3SRm 2/14	12.5 μ F - 450 VL
3SRm 2/21	16 μ F - 450 VL
3SRm 2/28	20 μ F - 450 VL
3SRm 2/41	30 μ F - 450 VL
3SRm 4/5	12.5 μ F - 450 VL
3SRm 4/8	12.5 μ F - 450 VL
3SRm 4/12	16 μ F - 450 VL
3SRm 4/16	20 μ F - 450 VL
3SRm 4/23	30 μ F - 450 VL
3SRm 5/5	12.5 μ F - 450 VL
3SRm 5/8	12.5 μ F - 450 VL
3SRm 5/11	16 μ F - 450 VL
3SRm 5/15	20 μ F - 450 VL
3SRm 5/23	30 μ F - 450 VL
4BLOCK	
4BLOCKm 2/7	20 μ F - 450 VL
4BLOCKm 2/10	20 μ F - 450 VL
4BLOCKm 2/13	35 μ F - 450 VL
4BLOCKm 2/18	35 μ F - 450 VL
4BLOCKm 4/5	20 μ F - 450 VL
4BLOCKm 4/7	20 μ F - 450 VL
4BLOCKm 4/9	35 μ F - 450 VL
4BLOCKm 6/10	35 μ F - 450 VL
4BLOCKm 4/13	35 μ F - 450 VL

MODEL	CAPACITOR
4BLOCKm 6/3	20 μ F - 450 VL
4BLOCKm 6/5	20 μ F - 450 VL
4BLOCKm 6/7	35 μ F - 450 VL
4BLOCKm 8/3	20 μ F - 450 VL
4BLOCKm 8/5	35 μ F - 450 VL
4BLOCKm 8/8	35 μ F - 450 VL
4PD	
4PDm/0.50	20 μ F - 450 VL
4PDm/0.75	25 μ F - 450 VL
4PDm/1	35 μ F - 450 VL
4PDm/1.5	40 μ F - 450 VL
4PDm/2	60 μ F - 450 VL
4PDm/3	75 μ F - 450 VL
4PS	
4PSm/0.50	20 μ F - 450 VL
4PSm/0.75	25 μ F - 450 VL
4PSm/1	35 μ F - 450 VL
4PSm/1.5	40 μ F - 450 VL
4PSm/2	60 μ F - 450 VL
4PSm/3	70 μ F - 450 VL
BC	
BCm 10/50	25 μ F - 450 VL
BCm 15/50	35 μ F - 450 VL
BCm 20/50	35 μ F - 450 VL
BC-MF	
BCm 10/50-MF	25 μ F - 450 VL
BCm 15/50-MF	35 μ F - 450 VL
BCm 20/50-MF	35 μ F - 450 VL
BC-ST	
BCm 10/50-ST	25 μ F - 450 VL
BCm 15/50-ST	35 μ F - 450 VL
BCm 20/50-ST	35 μ F - 450 VL
CK	
CKm 50	12.5 μ F - 450 VL
CKm 50-BP	12.5 μ F - 450 VL
CKR	
CKRm 90	20 μ F - 450 VL
CP	
CPm 100	10 μ F - 450 VL
CPm 130	12.5 μ F - 450 VL
CPm 132	14 μ F - 450 VL
CPm 150	20 μ F - 450 VL
CPm 158	20 μ F - 450 VL
CPm 170	31.5 μ F - 450 VL
CPm 170M	31.5 μ F - 450 VL
CPm 190	45 μ F - 450 VL
CPm 200	50 μ F - 450 VL
CPm 160A	50 μ F - 450 VL
CPm 160B	45 μ F - 450 VL
CPm 160C	31.5 μ F - 450 VL
CPm 220C	50 μ F - 450 VL
CP-ST4	
CPm 100-ST4	10 μ F - 450 VL

CAPACITORS

MODEL	CAPACITOR
CPm 130-ST4	12.5 μ F - 450 VL
CPm 132-ST4	14 μ F - 450 VL
CPm 150-ST4	20 μ F - 450 VL
CPm 158-ST4	20 μ F - 450 VL
CPm 170M-ST4	31.5 μ F - 450 VL
CPm 170-ST4	31.5 μ F - 450 VL
CPm 180-ST4	31.5 μ F - 450 VL
CPm 190-ST4	45 μ F - 450 VL
CPm 200-ST4	50 μ F - 450 VL
CP-ST6	
CPm 100-ST6	10 μ F - 450 VL
CPm 130-ST6	12.5 μ F - 450 VL
CPm 132-ST6	14 μ F - 450 VL
CPm 150-ST6	20 μ F - 450 VL
CPm 158-ST6	20 μ F - 450 VL
CPm 170M-ST6	31.5 μ F - 450 VL
CPm 170-ST6	31.5 μ F - 450 VL
CPm 180-ST6	31.5 μ F - 450 VL
CPm 190-ST6	45 μ F - 450 VL
CPm 200-ST6	50 μ F - 450 VL
D	
Dm 8	20 μ F - 450 VL
Dm 10	25 μ F - 450 VL
Dm 20	25 μ F - 450 VL
Dm 30	35 μ F - 450 VL
DAVIS	
DAVIS	31.5 μ F - 500 VL
DC	
DCm 10	20 μ F - 450 VL
DCm 20	20 μ F - 450 VL
DCm 30	25 μ F - 450 VL
DCm 42	50 μ F - 450 VL
DCm 43	60 μ F - 450 VL
F	
Fm 32/160B	50 μ F - 450 VL
Fm 32/160C	45 μ F - 450 VL
Fm 40/125B	45 μ F - 450 VL
Fm 40/125C	31.5 μ F - 450 VL
Fm 40/160C	50 μ F - 450 VL
Fm 50/125C	50 μ F - 450 VL
FAMILY	
FAMILY	12.5 μ F - 450 VL
FCR	
FCRm 80/2	10 μ F - 450 VL
FCRm 80/3	12.5 μ F - 450 VL
FCRm 80/4	14 μ F - 450 VL
FCRm 80/5	20 μ F - 450 VL
FCRm 100/3	14 μ F - 450 VL
FCRm 100/4	20 μ F - 450 VL
FCRm 100/5	25 μ F - 450 VL
FCRm 90/5	31.5 μ F - 450 VL
FCRm 90/6	45 μ F - 450 VL
FCRm 90/7	50 μ F - 450 VL

MODEL	CAPACITOR
FCRm 130/3	31.5 μ F - 450 VL
FCRm 130/4	45 μ F - 450 VL
FCRm 130/5	50 μ F - 450 VL
FCRm 130/6	50 μ F - 450 VL
FCRm 200/3	31.5 μ F - 450 VL
FCRm 200/4	45 μ F - 450 VL
FCRm 200/5	50 μ F - 450 VL
FCRm 200/6	50 μ F - 450 VL
FCRm 240/3	45 μ F - 450 VL
FCRm 240/4	50 μ F - 450 VL
FCRm 240/5	50 μ F - 450 VL
FUTURE JET	
FUTURE JETm 1A	14 μ F - 450 VL
FUTURE JETm 1B	12.5 μ F - 450 VL
FUTURE JETm 1C	10 μ F - 450 VL
FUTURE JETm 2A	25 μ F - 450 VL
FUTURE JETm 2AH	25 μ F - 450 VL
FUTURE JETm 2C	25 μ F - 450 VL
FUTURE JET-ST	
FUTURE JETm 1A-ST	14 μ F - 450 VL
FUTURE JETm 1B-ST	12.5 μ F - 450 VL
FUTURE JETm 1C-ST	10 μ F - 450 VL
FUTURE JETm 2A-ST	25 μ F - 450 VL
FUTURE JETm 2C-ST	25 μ F - 450 VL
HF	
HFm 4	20 μ F - 450 VL
HFm 6A	50 μ F - 450 VL
HFm 6B	45 μ F - 450 VL
HFm 6C	31.5 μ F - 450 VL
HFm 50A	14 μ F - 450 VL
HFm 50B	12.5 μ F - 450 VL
HFm 51A	20 μ F - 450 VL
HFm 51B	20 μ F - 450 VL
HFm 5A	25 μ F - 450 VL
HFm 5AM	45 μ F - 450 VL
HFm 5ARM	50 μ F - 450 VL
HFm 5B	20 μ F - 450 VL
HFm 5BM	31.5 μ F - 450 VL
HFm 70B	45 μ F - 450 VL
HFm 70C	31.5 μ F - 450 VL
HT	
HTm 10/3	45 μ F - 450 VL
HTm 10/4	50 μ F - 450 VL
HTm 10/5	50 μ F - 450 VL
HTm 3/4	31.5 μ F - 450 VL
HTm 3/5	31.5 μ F - 450 VL
HTm 3/6	45 μ F - 450 VL
HTm 3/7	50 μ F - 450 VL
HTm 5/2	31.5 μ F - 450 VL
HTm 5/3	31.5 μ F - 450 VL
HTm 5/4	45 μ F - 450 VL
HTm 5/5	50 μ F - 450 VL
HTm 5/6	50 μ F - 450 VL
HTm 8/3	31.5 μ F - 450 VL

MODEL	CAPACITOR
HTm 8/4	45 μ F - 450 VL
HTm 8/5	50 μ F - 450 VL
HTm 8/6	50 μ F - 450 VL
HT-PRO	
HTm 3/4 - PRO	31.5 μ F - 450 VL
HTm 3/5 - PRO	31.5 μ F - 450 VL
HTm 3/6 - PRO	45 μ F - 450 VL
HTm 3/7 - PRO	50 μ F - 450 VL
HTm 5/2 - PRO	31.5 μ F - 450 VL
HTm 5/3 - PRO	31.5 μ F - 450 VL
HTm 5/4 - PRO	45 μ F - 450 VL
HTm 5/5 - PRO	50 μ F - 450 VL
HTm 5/6 - PRO	50 μ F - 450 VL
HTm 8/3 - PRO	31.5 μ F - 450 VL
HTm 8/4 - PRO	45 μ F - 450 VL
HTm 8/5 - PRO	50 μ F - 450 VL
HTm 8/6 - PRO	50 μ F - 450 VL
HTm 10/3 - PRO	45 μ F - 450 VL
HTm 10/4 - PRO	50 μ F - 450 VL
HTm 10/5 - PRO	50 μ F - 450 VL
JCR1	
JCRm 1A	14 μ F - 450 VL
JCRm 1B	12.5 μ F - 450 VL
JCRm 1C	10 μ F - 450 VL
JCRm 2A	25 μ F - 450 VL
JCRm 2C	25 μ F - 450 VL
JSW1	
JSWm 1A	14 μ F - 450 VL
JSWm 1B	12.5 μ F - 450 VL
JSWm 1C	10 μ F - 450 VL
JSWm 2A	25 μ F - 450 VL
JSWm 2C	25 μ F - 450 VL
JSWm 3AH	50 μ F - 450 VL
JSWm 3AL	50 μ F - 450 VL
JSWm 3AM	50 μ F - 450 VL
JSWm 3BH	45 μ F - 450 VL
JSWm 3BL	45 μ F - 450 VL
JSWm 3BM	45 μ F - 450 VL
JSWm 3CH	31.5 μ F - 450 VL
JSWm 3CL	31.5 μ F - 450 VL
JSWm 3CM	31.5 μ F - 450 VL
MAGNIFICA	
MAGNIFICA 1m	20 μ F - 450 VL
MAGNIFICA 2m	20 μ F - 450 VL
MAGNIFICA 3m	31.5 μ F - 450 VL
MAGNIFICA 4m	45 μ F - 450 VL
MAGNIFICA 5m	50 μ F - 450 VL
MC	
MCm 10/45	20 μ F - 450 VL
MCm 15/45	25 μ F - 450 VL
MCm 15/50	50 μ F - 450 VL
MCm 20/50	50 μ F - 450 VL
MCm 30/50	60 μ F - 450 VL
MCm 30/65	60 μ F - 450 VL

MODEL	CAPACITOR
MC-F	
MCm 15/50-F	50 μ F - 450 VL
MCm 20/50-F	50 μ F - 450 VL
MCm 30/50-F	60 μ F - 450 VL
MCm 30/65-F	60 μ F - 450 VL
MK	
MKm 3/3	31.5 μ F - 450 VL
MKm 3/5	31.5 μ F - 450 VL
MKm 3/6	45 μ F - 450 VL
MKm 5/4	31.5 μ F - 450 VL
MKm 5/5	31.5 μ F - 450 VL
MKm 5/7	45 μ F - 450 VL
MKm 5/8	50 μ F - 450 VL
MKm 8/4	31.5 μ F - 450 VL
MKm 8/5	45 μ F - 450 VL
MKm 8/6	50 μ F - 450 VL
NGA	
NGAm 1A	20 μ F - 450 VL
NGAm 1B	16 μ F - 450 VL
NGAm 2A	20 μ F - 450 VL
NGAm 2B	20 μ F - 450 VL
NGAm 3A	50 μ F - 450 VL
NGAm 3B	50 μ F - 450 VL
NGAm 3C	45 μ F - 450 VL
NGAm 3D	31.5 μ F - 450 VL
NGA-PRO	
NGAm 1A-PRO	20 μ F - 450 VL
NGAm 1B-PRO	16 μ F - 450 VL
NGAm 2A-PRO	20 μ F - 450 VL
NGAm 2B-PRO	20 μ F - 450 VL
NGAm 3A-PRO	50 μ F - 450 VL
NGAm 3B-PRO	50 μ F - 450 VL
NGAm 3C-PRO	45 μ F - 450 VL
NGAm 3D-PRO	31.5 μ F - 450 VL
NK	
NKm 2/2 GE	20 μ F - 450 VL
NKm 2/3 GE	20 μ F - 450 VL
NKm 2/4 GE	25 μ F - 450 VL
NKm 2/5 GE	25 μ F - 450 VL
NKm 2/6 GE	35 μ F - 450 VL
NKm 4/3 GE	20 μ F - 450 VL
NKm 4/4 GE	25 μ F - 450 VL
NKm 4/5 GE	25 μ F - 450 VL
NKm 4/6 GE	35 μ F - 450 VL
NKm 8/3 GE	25 μ F - 450 VL
NKm 8/4 GE	35 μ F - 450 VL
PK	
PKm 100	31.5 μ F - 450 VL
PKm 200	45 μ F - 450 VL
PKm 300	50 μ F - 450 VL
PKm 60	10 μ F - 450 VL
PKm 65	14 μ F - 450 VL
PKm 80	20 μ F - 450 VL
PKm 90	20 μ F - 450 VL

CAPACITORS

MODEL	CAPACITOR
PKS	
PKSm 60	10 µF - 450 VL
PKSm 65	14 µF - 450 VL
PKSm 80	20 µF - 450 VL
PLUG & DRAIN	
RXm 2	10 µF - 450 VL
RXm 3	14 µF - 450 VL
TOP 2-FLOOR	10 µF - 450 VL
TOP 3	14 µF - 450 VL
PLURIJET	
PLURIJETm 3/100	14 µF - 450 VL
PLURIJETm 3/80	12.5 µF - 450 VL
PLURIJETm 4/100	20 µF - 450 VL
PLURIJETm 4/80	14 µF - 450 VL
PLURIJETm 3/120	14 µF - 450 VL
PLURIJETm 3/90	12.5 µF - 450 VL
PLURIJETm 4/120	20 µF - 450 VL
PLURIJETm 4/90	14 µF - 450 VL
PLURIJETm 3/130	31.5 µF - 450 VL
PLURIJETm 3/200	31.5 µF - 450 VL
PLURIJETm 4/130	45 µF - 450 VL
PLURIJETm 4/200	45 µF - 450 VL
PLURIJETm 5/130	50 µF - 450 VL
PLURIJETm 5/200	50 µF - 450 VL
PLURIJETm 5/90	31.5 µF - 450 VL
PLURIJETm 6/90	45 µF - 450 VL
PQ	
PQm 100	31.5 µF - 450 VL
PQm 200	45 µF - 450 VL
PQm 300	50 µF - 450 VL
PQm 60	10 µF - 450 VL
PQm 61	10 µF - 450 VL
PQm 65	14 µF - 450 VL
PQm 80	20 µF - 450 VL
PQm 90	20 µF - 450 VL
PQ81-Bs, PQ81-PPS	
PQm 81-Bs PQm 81-PPS	14 µF - 450 VL
PQA	
PQAm 60	10 µF - 450 VL
PQAm 70	16 µF - 450 VL
PQAm 90	20 µF - 450 VL
PQ-Bs	
PQm 60-Bs	10 µF - 450 VL
PQm 65-Bs	14 µF - 450 VL
PRIMA	
PRIMA 50m	10 µF - 450 VL
PRIMA 75m	12 µF - 450 VL
PRIMA 100m	20 µF - 450 VL
PRIMA 150m	20 µF - 450 VL
PV	
PVm 55	10 µF - 450 VL
PVm 60	10 µF - 450 VL
PVm 65	14 µF - 450 VL
PVm 70	25 µF - 450 VL

MODEL	CAPACITOR
PVm 81	14 µF - 450 VL
PVm 90	25 µF - 450 VL
RX	
RXm 1	10 µF - 450 VL
RXm 2	10 µF - 450 VL
RXm 3	14 µF - 450 VL
RXm 4	20 µF - 450 VL
RXm 5	25 µF - 450 VL
RX-VORTEX	
RXm 2/20	10 µF - 450 VL
RXm 3/20	14 µF - 450 VL
RXm 4/40	20 µF - 450 VL
RXm 5/40	25 µF - 450 VL
SPRINKLER	
SKRm 1.1	31.5 µF - 450 VL
SKRm 1.5	45 µF - 450 VL
TEX	
TEX 2	10 µF - 450 VL
TEX 3	12.5 µF - 450 VL
TOP	
TOP 1	10 µF - 450 VL
TOP 2	10 µF - 450 VL
TOP 3	14 µF - 450 VL
TOP 4 N	16 µF - 450 VL
TOP 5 N	20 µF - 450 VL
TOP FLOOR	
TOP 1-FLOOR	10 µF - 450 VL
TOP 2-FLOOR	10 µF - 450 VL
TOP 3-FLOOR	14 µF - 450 VL
TOP MULTI	
TOP MULTI 1	10 µF - 450 VL
TOP MULTI 2	12.5 µF - 450 VL
TOP MULTI 3	12.5 µF - 450 VL
TOP MULTI 4	14 µF - 450 VL
TOP MULTI 5	14 µF - 450 VL
TOP MULTI-AD	
TOP MULTI 1-AD	10 µF - 450 VL
TOP MULTI-EVO	
TOP MULTI 1 EVO	10 µF - 450 VL
TOP MULTI 2-EVO	12.5 µF - 450 VL
TOP MULTI 3-EVO	12.5 µF - 450 VL
TOP MULTI 4-EVO	14 µF - 450 VL
TOP MULTI 5-EVO	14 µF - 450 VL
TOP MULTI-EVOTECH	
TOP MULTI-EVOTECH 2	12.5 µF - 450 VL
TOP MULTI-EVOTECH 3	12.5 µF - 450 VL
TOP MULTI-EVOTECH 4	14 µF - 450 VL
TOP MULTI-EVOTECH 5	14 µF - 450 VL
TOP MULTI-TECH	
TOP MULTI-TECH 2	12.5 µF - 450 VL
TOP MULTI-TECH 3	12.5 µF - 450 VL
TOP MULTI-TECH 4	14 µF - 450 VL
TOP MULTI-TECH 5	14 µF - 450 VL

MODEL	CAPACITOR
TOP VORTEX	
TOP 1 - VORTEX	10 µF - 450 VL
TOP 1 - VORTEX/GM	10 µF - 450 VL
TOP 2 - VORTEX	10 µF - 450 VL
TOP 2 - VORTEX/GM	10 µF - 450 VL
TOP 3 - VORTEX	14 µF - 450 VL
TOP 3 - VORTEX/GM	14 µF - 450 VL
TRITUS	
TRm 0.75	25 µF - 450 VL / 80 µF - 450 VL
TRm 0.9	25 µF - 450 VL / 80 µF - 450 VL
TRm 1.1	25 µF - 450 VL / 80 µF - 450 VL
TRm 1.3	25 µF - 450 VL / 80 µF - 450 VL
TRm 1.5	50 µF - 450 VL / 80 µF - 450 VL
TRm 2.2 AP	60 µF - 450 VL / 120 µF - 330 VL
TIGm 0.55	25 µF - 450 VL
TIGm 0.75	25 µF - 450 VL
TIGm 1.1	35 µF - 450 VL
TIGm 1.3	35 µF - 450 VL
TRITUS-TX	12.5 µF - 450 VL
UP	
UPm 2/2-GE	20 µF - 450 VL
UPm 2/3-GE	20 µF - 450 VL
UPm 2/4-GE	25 µF - 450 VL
UPm 2/5-GE	25 µF - 450 VL
UPm 2/6-GE	35 µF - 450 VL
UPm 4/3-GE	20 µF - 450 VL
UPm 4/4-GE	25 µF - 450 VL
UPm 4/5-GE	25 µF - 450 VL
UPm 4/6-GE	35 µF - 450 VL
UPm 8/3-GE	25 µF - 450 VL
UPm 8/4-GE	35 µF - 450 VL
VILLABELLA	
VILLABELLA 50m	20 µF - 450 VL
VILLABELLA 75m	20 µF - 450 VL
VILLABELLA 100m	25 µF - 450 VL
VILLABELLA 150m	30 µF - 450 VL
VILLABELLA 200m	40 µF - 450 VL
VILLABELLA 300m	40 µF - 450 VL
VX	
VXm 10/35	25 µF - 450 VL
VXm 10/50	25 µF - 450 VL
VXm 15/35	35 µF - 450 VL
VXm 15/50	35 µF - 450 VL
VXm 20/35	35 µF - 450 VL
VXm 20/50	35 µF - 450 VL
VXm 8/35	20 µF - 450 VL
VXm 8/50	20 µF - 450 VL
VXC	
VXCm 10/35	20 µF - 450 VL
VXCm 10/45	20 µF - 450 VL
VXCm 15/35	25 µF - 450 VL
VXCm 15/45	25 µF - 450 VL
VXCm 15/50	50 µF - 450 VL
VXCm 15/65	50 µF - 450 VL
VXCm 20/50	50 µF - 450 VL

MODEL	CAPACITOR
VXCm 20/65	50 µF - 450 VL
VXCm 30/50	60 µF - 450 VL
VXCm 30/65	60 µF - 450 VL
VXC-F	
VXCm 15/50-F	50 µF - 450 VL
VXCm 15/65-F	50 µF - 450 VL
VXCm 20/50-F	50 µF - 450 VL
VXCm 20/65-F	50 µF - 450 VL
VXCm 30/50-F	60 µF - 450 VL
VXCm 30/65-F	60 µF - 450 VL
VX-MF	
VXm 10/35-MF	25 µF - 450 VL
VXm 10/50-MF	25 µF - 450 VL
VXm 15/35-MF	35 µF - 450 VL
VXm 15/50-MF	35 µF - 450 VL
VXm 20/35-MF	35 µF - 450 VL
VXm 20/50-MF	35 µF - 450 VL
VXm 8/35-MF	20 µF - 450 VL
VXm 8/50-MF	20 µF - 450 VL
VX-ST	
VXm 10/35-ST	25 µF - 450 VL
VXm 10/50-ST	25 µF - 450 VL
VXm 15/35-ST	35 µF - 450 VL
VXm 15/50-ST	35 µF - 450 VL
VXm 20/35-ST	35 µF - 450 VL
VXm 20/50-ST	35 µF - 450 VL
VXm 8/35-ST	20 µF - 450 VL
VXm 8/50-ST	20 µF - 450 VL
WR	
WRm 40/125-SA	20 µF - 450 VL
WRm 40/125-SB	20 µF - 450 VL
WRm 50/125A	50 µF - 450 VL
WRm 50/125B	45 µF - 450 VL
WRm 50/125C	31.5 µF - 450 VL
WRm 50/125-SA	50 µF - 450 VL
WRm 50/125-SB	45 µF - 450 VL
ZX1	
ZXm 1A/40	16 µF - 450 VL
ZXm 1B/40	12.5 µF - 450 VL
ZXm 2/30	20 µF - 450 VL
ZXm 2/40	20 µF - 450 VL
ZX2-GM	
ZXm 2/30-GM	20 µF - 450 VL
ZXm 2/40-GM	20 µF - 450 VL

CABLE SIZING FOR SUBMERSIBLE MOTORS

SINGLE-PHASE 230 V - 50 Hz

MOTOR POWER (P ₂)		cable cross-section in mm ²						
kW	HP	4 x 1	4 x 1.5	4 x 2.5	4 x 4	4 x 6	4 x 10	4 x 16
maximum cable length in metres								
0.37	0.50	60	90	140				
0.55	0.75	45	70	110	180			
0.75	1	35	50	85	140	210		
1.1	1.5	25	35	60	95	145	240	
1.5	2		30	45	75	115	190	305
2.2	3			30	50	75	125	200

Three-phase 230 V — 50 Hz

MOTOR POWER (P ₂)		cable cross-section in mm ²										
kW	HP	4x1	4 x 1.5	4 x 2.5	4 x 4	4 x 6	4 x 10	4 x 16	4 x 25	4 x 35	4 x 50	4 x 70
maximum cable length in metres												
0.37	0.50	100	152	255								
0.55	0.75	83	126	210	338							
0.75	1	65	99	165	265	405						
1.1	1.5	48	72	120	192	292	485					
1.5	2		53	88	142	215	360					
2.2	3			60	97	147	245	392				
3	4			47	73	110	183	295	510			
4	5.5				55	83	138	220	380			
5.5	7.5					60	100	160	275	385		
7.5	10					45	73	114	195	275	395	
9.2	12.5						64	100	157	220	315	
11	15						54	87	135	190	270	378
13	17.5							75	117	164	236	330
15	20							65	102	144	205	287
18.5	25								82	114	162	225
22	30								69	95	137	190
30	40									70	102	142
37	50									52	68	95

Three-phase 400 V — 50 Hz

MOTOR POWER (P ₂)		cable cross-section in mm ²										
kW	HP	4x1	4 x 1.5	4 x 2.5	4 x 4	4 x 6	4 x 10	4 x 16	4 x 25	4 x 35	4 x 50	4 x 70
maximum cable length in metres												
0.37	0.50	300										
0.55	0.75	250	380									
0.75	1	195	295									
1.1	1.5	145	215	360								
1.5	2	105	160	265	425							
2.2	3	70	110	180	290	440						
3	4	55	85	140	220	330						
4	5.5	40	60	105	165	250	415					
5.5	7.5		45	75	120	180	300	480				
7.5	10		35	55	95	135	220	340	585			
9.2	12.5			47	75	115	190	300	470			
11	15			40	65	95	160	260	405			
13	17.5				60	85	140	225	350	490		
15	20				50	75	125	195	305	430		
18.5	25					58	100	155	245	340	485	
22	30					49	85	130	205	285	410	570
30	40					36	63	96	152	210	305	425
37	50						47	74	115	156	205	284

Voltage drop 3% - Maximum ambient temperature + 30 °C

PRESSURE DROP DIAGRAM

(for straight pipes of 15-250 mm internal diameter and flow rates of 8 to 8330 l/min)

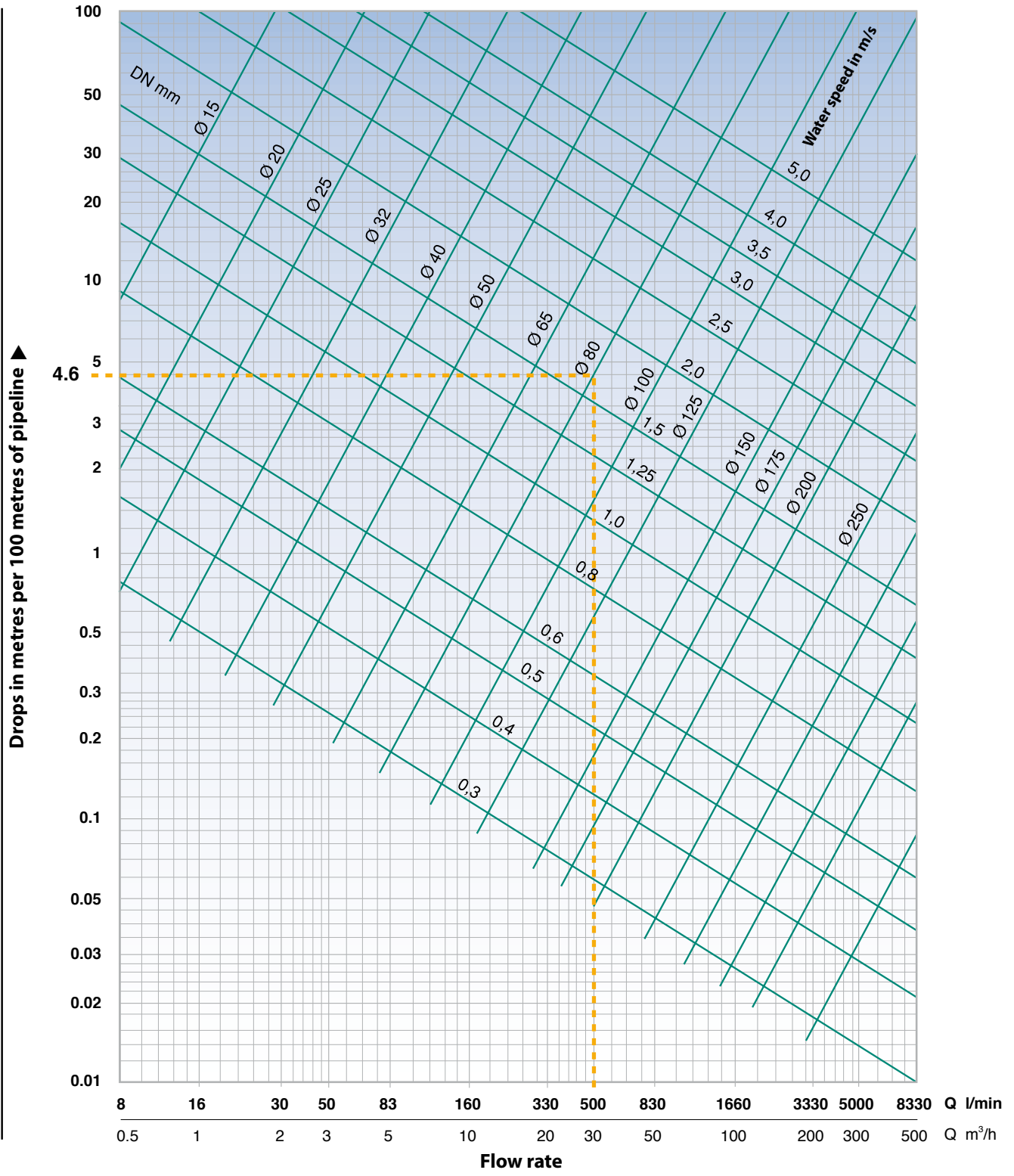

The data in the table are valid for cold water and for liquids with the same kinematic viscosity, for factory-new, cast-iron pipes. The pressure drops h_v resulting from the tables must be multiplied by: **0.8** for steel pipes, new rolled; **1.25** for iron pipes, old, slightly rusted; **1.7** for old pipes for which the reduced cross-section due to scaling must be taken into account.

➔ **EXAMPLE:** Flow data $Q = 500$ l/min, new steel pipe Ø 80 mm, pipe length 50 m.

On the horizontal axis, locate the flow rate and continue vertically until you meet the line of DN 80 mm.

Pressure losses are therefore read on the vertical axis.

$h_v = 4.6$ m per 100 m of pipe.

$h_{v1} = 4.6 \times 0.8 = 3.68$ m/100 (steel tube).

To consider the actual length of the pipe:

$h_{v2} = 3.68 \times 50:100 = 1.84$ m (for 50 m of pipe).

The flow velocity is determined by considering the point of intersection between the oblique straight lines to be 1.5-2 m/sec. Thus in the present case we have:

C = 1.7 metres/sec. ac.

CONVERSION OF UNITS OF MEASUREMENT

LENGTH

millimeter	centimeter	metres	inch	foot	yard
mm	cm	m	in	ft	yd
1	0.1	0.001	0.0394	0.0033	0.0011
10	1	0.01	0.3937	0.0328	0.0109
1000	100	1	39.3701	3.2808	10.936
25.4	2.54	0.0254	1	0.0833	0.0278
304.8	30.48	0.3048	12	1	0.3333
914.4	91.44	0.9144	36	3	1

1 kilometre = 1000 metres = 0.62137 miles - 1 mile = 1609.34 metres = 1.60934 kilometres

VOLUME

cubic metre	litre	millilitre	gallon Imp.	US gallon	cube foot
m ³	l	ml	Imp. gal.	US gal	ft ³
1	1000	1 x 10 ⁶	220	264.2	35.3147
0.001	1	1000	0.22	0.2642	0.0353
1 x 10 ⁻⁶	0.001	1	2.2 x 10 ⁻⁴	2.642 x 10 ⁻⁴ = 1047.75	3.53 x 10 ⁻⁵
0.00455	4.546	4546	1	1.201	0.1605
0.00378	3.785	3785	0.8327	1	0.1337
0.0283	28.317	28.317	6.2288	7.4805	1

WEIGHT

kilogramme	pound	centiweight	ton	t long	t short
kg	lb	cwt	t	tn	sh. tn
1	2.205	0.0197	0.001	9.84 x 10 ⁻⁴	0.0011
0.454	1	0.0089	4.54 x 10 ⁻⁴	4.46 x 10 ⁻⁴	5.0 x 10 ⁻⁴
50.802	112	1	0.0508	0.05	0.056
1000	2204.6	19.684	1	0.9842	1.1023
1016	2240	20	1.0161	1	1.102
907.2	2000	17.857	0.9072	0.8929	1

VOLUMETRIC FLOW

litres latter	litres minute	Cubic metres time	cubic feet time	cubic feet minute	Imp. gal. minute	US gal. minute	US barrel day
l/s	l/min	m ³ /h	ft ³ /h	ft ³ /min	Imp. gal/min	US gal/min	mineral oil US barrel/g
1	60	3.6	127.133	2.1189	13.2	15.85	543.439
0.017	1	0.06	2.1189	0.0353	0.22	0.264	9.057
0.278	16.667	1	35.3147	0.5886	3.666	4.403	150.955
0.008	0.472	0.0283	1	0.0167	0.104	0.125	4.275
0.472	28.317	1.6990	60	1	6.229	7.480	256.475
0.076	4.546	0.2728	9.6326	0.1605	1	1.201	41.175
0.063	3.785	0.2271	8.0209	0.1337	0.833	1	34.286
0.002	0.110	0.0066	0.2339	0.0039	0.024	0.029	1

PRESSURE AND HEAD

Newton metres panel/board	kilopascal	bar	kilogramme force centimeter panel/board	pound force inch panel/board	foot Water %	metres Water %	millimeter mercury	inch mercury
N/m ²	kPa	bar	kgf/cm ²	psi	ft H ₂ O	m H ₂ O	mm Hg	In Hg
1	0.001	1 x 10 ⁻⁵	1.02 x 10 ⁻⁵	1.45 x 10 ⁻⁴	3.35 x 10 ⁻⁴	1.02 x 10 ⁻⁴	0.0075	2.95 x 10 ⁻⁴
1000	1	0.01	1.02 x 10 ⁻²	0.145	0.335	0.102	7.5	0.295
100000	100	1	1.02	14.5	33.52	10.2	750.1	29.53
98067	98.07	0.981	1	14.22	32.81	10	735.6	28.96
6895	6.895	0.069	0.0703	1	2.31	0.703	51.72	2.036
2984	2.984	0.03	0.0305	0.433	1	0.305	22.42	0.882
9789	9.789	0.098	0.1	1.42	3.28	1	73.42	2.891
133.3	0.133	0.0013	0.0014	0.019	0.045	0.014	1	0.039
3386	3.386	0.0338	0.0345	0.491	1.133	0.345	25.4	1

PUMP SELECTOR

■ The spring of data

- ※ The Pedrollo pump selector.
- ※ The tool that helps you select the right pump for your requirements.

The screenshot displays the Pedrollo Pump Selector web application. At the top, there is a navigation bar with the Pedrollo logo and the tagline "the spring of life". The main content area is divided into several sections:

- Prodotti:** A grid of pump models including PK, PQ, PKS, PQ-EKO, PQ-PRO, PQ-8s, PQA, PQ 3000, PV, CK, CKR, JSW1, JSW2, JSW3, SPRINKLER, JCR1, JCR2, PLURIJET 80x-100X, PLURIJET 80-100, and PLURIJET 90x-200X.
- Filtri:** A sidebar with a search bar and filters for "Tipologia liquido" (Tutti) and application types (Agricolo, Civile, Domestico, Industriale).
- Punto di Lavoro:** A section for selecting work points with input fields for Portata (l/min), Prevalenza (m), Altezza geodetica (m), and NPSHa (m), along with a "Selezionare" button and a "Reset" button.

To access the **Pump Selector - The spring of data**
<https://springofdata.pedrollo.com/selector>

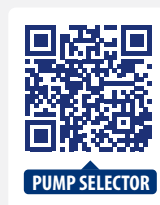

For a general overview watch the Video Tutorial
<https://www.youtube.com/watch?v=P9KGM0aDz58>

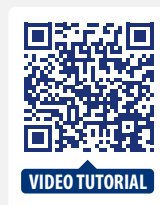



PEDROLLO SpA

Via Enrico Fermi 7
37047 San Bonifacio (VR)

telefono: +39 045 6136311

fax: +39 045 7612253

sales@pedrollo.com

www.pedrollo.com

The data contained in this publication should not be regarded as binding.
PEDROLLO S.p.a. reserves the right to make any changes it deems appropriate to improve its production.

CODE Z-CATG050ITV23