

**NETZSCH**



## NOTOS® Multi Screw Pumps

High Efficiency and Unique Design

# NOTOS® MULTI SCREW PUMPS

## 3 ranges for all applications

Since 1979 NETZSCH has been manufacturing multi screw pumps to serve a wide range of industries and applications. The most advanced technology is utilized to produce these pumps. Reliability, durability and experience are some reasons why you should choose NETZSCH.

### Range of applications

NOTOS® pumps are designed to convey low to well lubricating fluids, low to high viscosity, shear sensitive or chemically aggressive media. The markets covered are:

- Oil & Gas
- Marine Industry
- Power Generation
- Process Industry
- Tank Storage

### Broad range of materials

Our range of metallic materials extends from grey cast iron and chrome-nickel steel to duplex, super duplex or hastelloy steel. Further metal material options on request.

- No dynamically loaded rubber parts
- Static seals from NBR to FFKM

### Capacity and pressure ranges

Multi Screw Pumps are known as pumps for low to high flows and low to high pressures

- Flow rate up to 1500 m<sup>3</sup>/h
- Pressure rate up to 80 bar
- Viscosities up to 200.000 cSt
- Temperature up to 300 °C

### “High Efficiency Unique Design”

Due to the “High Efficiency Unique Design” (HEUD), the pumps are optimized in order to increase their performance. Characteristics of this design are:

- Extremely small tolerances due to the state-of-the-art technology.
- Optimized spindle profile
- Optimized pump chamber

### Characteristics

- Self-priming
- Good suction capability
- Continuous flow with low pulsation
- Flow with minimal turbulences
- Gentle product handling
- Low maintenance
- Low lifecycle cost
- Long service life
- Quiet operation
- Several mechanical seal options
- Magnetic drive optional
- Extremely low noise and vibrations

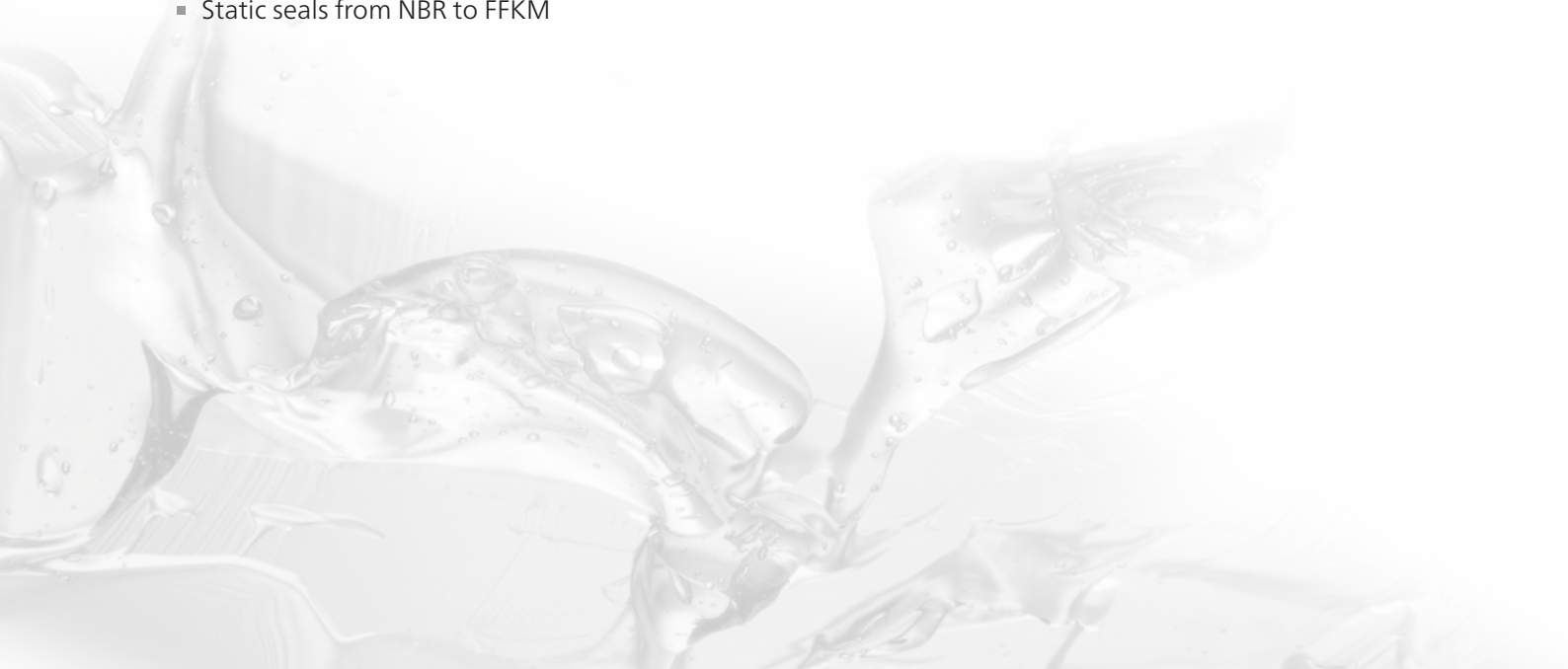

The NOTOS® multi screw pump family comprises three series in multiple arrangements which serve a wide range of industries and applications. The superior quality standard meets the highest level of requirements from our customers.

Three different pump series to meet your individual demands:



Configuration samples of all series

## 2 NS – Two Screw Pump

Fluid properties:

- From non to light abrasive
- Corrosive and non corrosive
- Low to medium viscosities
- Low to well lubricant fluids

## 3 NS – Three Screw Pump

Fluid properties:

- Non abrasive
- Non corrosive
- Low to medium viscosities
- Lubricant

## 4 NS – Geared Twin Screw Pump

Fluid properties:

- From non to medium abrasive
- Corrosive and non corrosive
- Low to high viscosities
- Non lubricant and lubricant

# 2NS SERIES

NOTOS® two screw pumps have one drive screw, transferring torque through a hydrodynamic film to the rotating intermeshing driven screw.

## Performance

- Flow up to 500 m<sup>3</sup>/h (2200 gpm)
- Pressure up to 16 bar (230 psi)
- Temperature up to 300°C (570°F)
- Viscosity up to 100.000 cSt

## Accessories

- Internal or external relief valve
- Vibration sensors
- Temperature sensors
- API 682 cartridge seals
- Various API seal plans

## Arrangements

- Foot, vertical, semi-submersible, housing with replaceable liner or flange mounted
- Heating jacket optional

### 1 Screws

Nitrated in alloy steel or in stainless steel. The HEUD (High Efficiency Unique Design) provides excellent performance.

### 2 Housing

Various ports configurations such as top top, side top or in line.

### 3 Bearing Bushes

Internal bearing bushes helps to support radial loads.

### 4 Mechanical Seal

Under suction pressure just one mechanical seal is required for the 2NS. Magnetic drive optional.

## Advantages

- High efficiency
- Hydraulically balanced
- Quiet operation
- Long service life
- Low pulsation
- Excellent suction capability
- API 676 3<sup>rd</sup> ed., optional

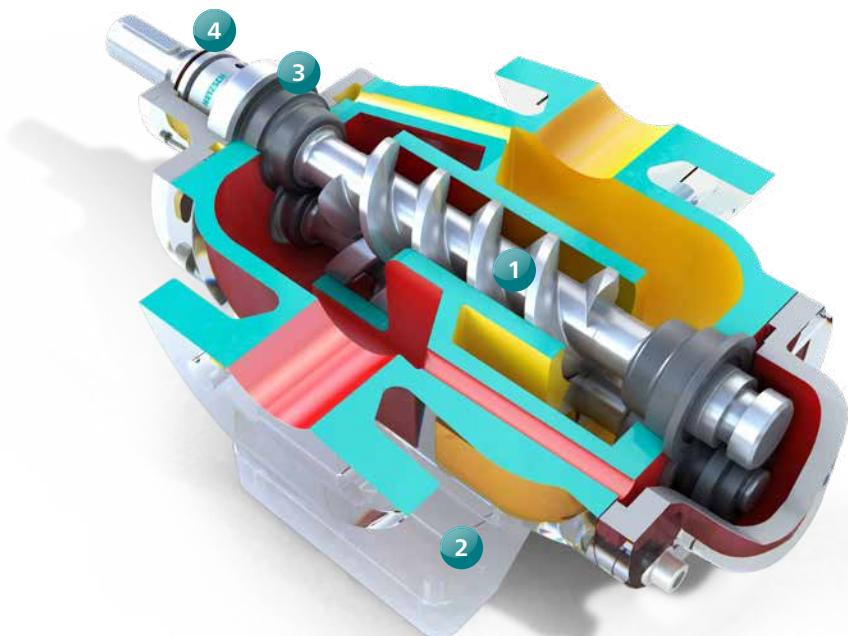

# 3NS SERIES

NOTOS® three screw pumps have one drive screw, transferring torque through a hydrodynamic film to the two rotating intermeshing driven screws.

## Performance

- Flow up to 350 m<sup>3</sup>/h (1500 gpm)
- Pressure up to 80 bar (1160 psi)
- Temperature up to 300°C (570°F)
- Viscosity up to 15.000 cSt

## Accessories

- Internal or external relief valve
- Vibration sensors
- Temperature sensors
- API 682 cartridge seals
- Various API seal plans

## Arrangements

- Foot, vertical, semi-submersible
- Housing with replaceable liner, light, top tank version
- Heating jacket optional

### 1 Screws

Nitrated in alloy steel or in stainless steel. The HEUD (High Efficiency Unique Design) provides excellent performance.

### 2 Housing

Various ports configurations such as top top, side top or in line.

### 3 Bearing Bushes

Nitrated bushes help to prevent start up failures and help to support radial loads.

### 4 Mechanical Seal

Under suction pressure just one mechanical seal is required for the 3NS. Magnetic drive optional.

## Advantages

- High efficiency
- Easy maintenance
- Lightweight and small footprint
- Low pulsation
- API 676 3<sup>rd</sup> ed., optional

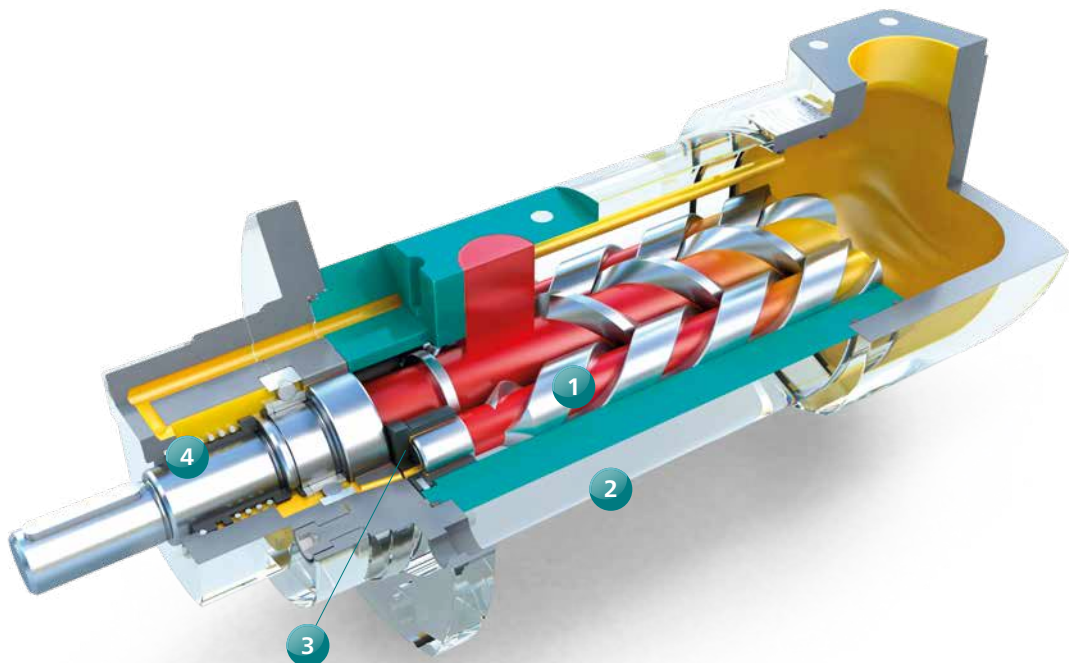



# 4NS SERIES

NOTOS® geared twin screw pumps have two shafts and four screws. The torque is transferred to the driven shaft via helical gears. The design is hydraulically balanced.

## Performance

- Flow up to 1500 m<sup>3</sup>/h (6600 gpm)
- Pressure up to 80 bar (1160 psi)
- Temperature up to 300°C (570°F)
- Viscosity up to 200.000 cSt

## Accessories

- Internal or external relief valve
- Vibration sensors
- Temperature sensors
- API 682 cartridge seals
- Various API seal plans

## Arrangements

- Housing with replaceable liner
- Heating jacket optional

### 1 Screws

Nitrated in alloy steel or in stainless steel. The HEUD (High Efficiency Unique Design) provides excellent performance.

### 2 Housing

Various ports configurations such as top top, side top or in line.

### 3 Timing Gear

Helical or spur timing gears transfer the torque with reduced vibration and noise.

### 4 Mechanical Seal

Four mechanical seals under suction pressure.

## Advantages

- High Efficiency
- No metal to metal contact
- Small footprint
- Long service life
- Excellent suction capability
- API 676 3<sup>rd</sup> ed., optional

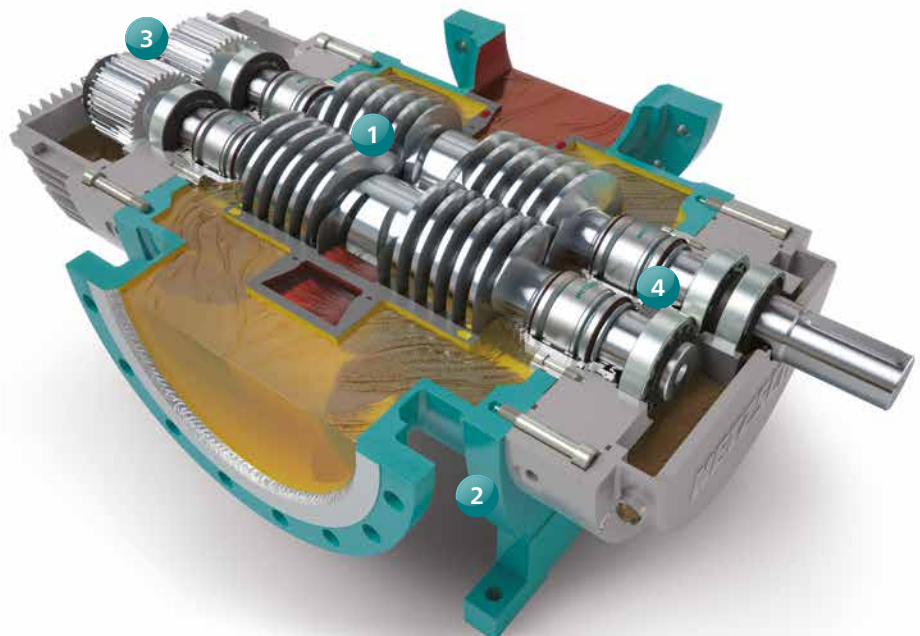

# APPLICATION EXAMPLES

## Compressor Lubrication

- Pump NOTOS®: 3 NS
- Media: Lube oil
- Flow rate: 25 m<sup>3</sup>/h
- Pressure: 7,5 bar
- Temperature: 50 °C
- Viscosity: 70 to 1000 cSt
- Location: India



## Burner Feeding

- Pump NOTOS®: 2 NS
- Media: Fuel Oil
- Flow rate: 16 m<sup>3</sup>/h
- Pressure: 4 bar
- Temperature: 50 °C
- Viscosity: 30 cSt
- Location: Italy



## Loading/Unloading

- Pump NOTOS®: 4 NS
- Media: Vacuum residue
- Flow rate: 550 m<sup>3</sup>/h
- Pressure: 10 to 15 bar
- Temperature: 50 to 150 °C
- Viscosity: 200 to 900 cSt
- Location: Turkey





The NETZSCH Group is a mid-sized, family-owned German company engaging in the manufacture of machinery and instrumentation with worldwide production, sales, and service branches.

The three Business Units – Analyzing & Testing, Grinding & Dispersing and Pumps & Systems – provide tailored solutions for highest-level needs. Over 3,400 employees at 210 sales and production centers in 35 countries across the globe guarantee that expert service is never far from our customers.

The NETZSCH Business Unit Pumps & Systems offers with NEMO® progressing cavity pumps, TORNADO® rotary lobe pumps, NOTOS® multiple screw pumps, macerators/grinders, dosing technology and equipment custom built and challenging solutions for different applications on a global basis.

NETZSCH Pumps & Systems – Solutions you can trust ■

NETZSCH Pumpen & Systeme GmbH  
Geretsrieder Straße 1  
84478 Waldkraiburg  
Germany  
Tel.: +49 8638 63-0  
Fax: +49 8638 67981  
info.nps@netzsch.com

**NETZSCH®**

[www.netzsch.com](http://www.netzsch.com)